



SAFETY WITH VENTILATION POWER
GEZE DRIVE TECHNOLOGY FOR
SMOKE AND HEAT EXTRACTION SYSTEMS (RWA)



Table of Contents

Foreword	Safety with ventilation power – GEZE RWA systems	4
Chapter 1	Overview of types of windows, RWA system structure and components	6
Chapter 2	GEZE RWA exhaust systems	
	Electrically operated chain drives	
	E 740	12
	E 820	28
	E 860	34
	E 920 - E 990	46
	Locking drives	
	E 905 / E 906	50
	Electrically operated spindle drives	
	E 250 / E 250 VdS / E 250 AB	53
	E 1500 N and E 1500 S	60
	E 3000	65
	Opening and locking systems	
	RWA 100E	71
	RWA 105E	74
	RWA 110E	78
	Electric linear drives E 212 and E 205	81
Chapter 3	GEZE RWA fresh air systems	
	RWA TÖ	84
	RWA K 600	88
	RWA AUT	97
Chapter 4	GEZE RWA special variations	
	RWA-EM "OPEN"	101
	RWA-CO2 "OPEN"	103
Chapter 5	GEZE RWA Accessories	105
Chapter 6	Legal Basis	
	Building law	111
	Construction products law	114
	Servicing and maintenance	115

GEZE RWA systems – Safety with ventilation power

GEZE offers numerous opening and closing solutions for windows for a wide range of different application cases. The varied products on offer range from a large selection of drive systems for regular ventilation to complete fresh and exhaust air solutions for safe and fast natural smoke extraction (NRA) – **safety with ventilation power**.

We at GEZE attach great importance to all-round support – from planning through help with technical implementation through to servicing and maintenance.



FOREWORD



For fire protection, a distinction is drawn between the concepts of “fire-fighting” and “preventive fire protection”:

- **Fire-fighting:** The term “fire-fighting” covers all steps taken in the event of a fire to combat the dangers posed to life, health and property.
- **Preventive fire protection:** This term covers all steps taken to prevent a fire from breaking out or spreading and to keep escape routes open. The aim is to obstruct the spread of a fire long enough for people to be able to escape safely by their own efforts and to give the fire brigade time to allow people to escape safely from the building.

The smoke and heat extraction system (RWA) is classed under “preventive fire protection” and will save lives in the event of a fire. The legal foundations are the building codes, special building codes and technical regulations of Germany on the federal and state levels.

During a fire considerable quantities of combustion products such as smoke and fire gases and heat energy are produced. The most important task of the RWA system is to discharge the products of combustion from the building efficiently and quickly. Rooms and buildings without a RWA system fill up with toxic smoke gases within a very short time.

The risk for people trying to escape and the rescue services is significantly increased in buildings without a RWA system since the lack of smoke and heat extraction leads to an uncontrolled blazing fire, and the thick smoke makes active and passive rescue impossible.

FOREWORD



Fire victims caused by direct contact with fire only occur very rarely; almost 90% of all fatal fire accidents are due to suffocation caused by smoke gases. "Fire victims are smoke victims" – there are two reasons for this:

- Lethal constituents in smoky gas
- Corrosive components which burn the lungs and airways when breathed in

Large amounts of smoke gas rise on account of thermal buoyancy and fill the room or the building with smoke. The high ambient temperature can lead to the building collapsing in worst cases.

Conservation of the property structure is thus one of the major tasks for the RWA system. This way people can escape from the building through their own efforts, and the rescue services can carry out active rescue – evacuation of the building – for longer.

How natural smoke extraction works:

Triggered by automatic smoke detectors or manually, the smoke and heat extraction system vents are opened with the aid of electrically operated drives in the upper part of the building. The thermally ascending smoke gases can escape through these vents even during the initial phase. The necessary fresh air vents in the lower part of the building assist this process by balancing out the necessary mass flow.

In summary, the following objectives are achieved by the use of smoke and heat extraction systems in buildings:

▪ Protection of individuals	▪ Environmental protection	▪ Protection of property
Keeping rescue routes smoke-free: <ul style="list-style-type: none"> ▪ Active rescue ▪ Passive rescue ▪ Localisation of the fire 	Reducing damage to the environment: <ul style="list-style-type: none"> ▪ Minimisation of damage caused by fire-extinguishing activities ▪ Minimum use of extinguishing agents 	Conserving the building structure: <ul style="list-style-type: none"> ▪ Support for fire-fighting ▪ Ventilation of the fire ▪ Minimisation of the thermal load



Smoke spreading with RWA



Smoke spreading without RWA



SUMMARY OF WINDOW TYPES

A wide range of different window and casement types are used in exterior walls:



Bottom hung casement, inward opening

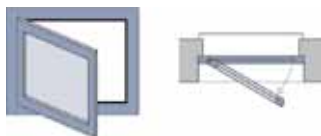

Side hung casement, inward opening



Vertically pivoted casement, inward opening to the left



Bottom hung casement, outward opening



Side hung casement, outward opening



Vertically pivoted casement, inward opening to the right



Top hung casement, inward opening



Horizontally pivot hung casement, inward opening

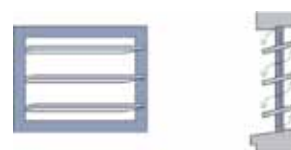

Louvre window



Top hung casement, outward opening



Horizontally pivot hung casement, outward opening



Skylight, outward opening

GEZE RWA SYSTEMS

Components of an RWA system

Electromechanical drives

Electromechanical drives are used for opening and closing the fresh air and exhaust air areas for RWA and ventilation. A functional test on the drives can be carried out at any time without material consumption. The SHEV structure and the design allow flexible adaptation to all window and frame profiles as well as flexible assembly possibilities in connection with all profile systems.

Electrical control

The control unit has two independent power supplies (mains and battery) which guarantee operation in any situation. The functional safety of the cables and triggering devices is monitored. In the event of a fire, the smoke parameter quickly triggers the automatic fire detector or external fire alarm system. There are also numerous convenience ventilation functions available e.g. automatic, temporary ventilation or stroke limitation for regular daily ventilation according to requirements.

The RWA vents can be triggered depending on wind direction, so that in the event of a fire the building side away from the wind can be used for smoke dissipation.

Electrical manual control unit

The electrical manual control unit is used for the manual triggering of the RWA system and for indicating operating and alarm states.

Automatic detector and sensors

There are different sensors and detectors available for safety functions or for convenient natural ventilation. Wind and rain detectors, temperature sensors and regulators are used for automatic ventilation control and weather monitoring. Through the building management system, sensors from other systems can also be used for RWA and ventilation control.

Smoke detectors, temperature detectors or heat differential detectors are designed to detect a fire and trigger smoke extraction fast and automatically.

GEZE RWA SYSTEMS

System structure – functional description

The control system of an electrical RWA mainly comprises the components shown in the system illustration. The system covers two major task groups: **emergencies** and routine **ventilation**.

A GEZE smoke and heat extraction system is used for the routine ventilation of rooms and also for smoke extraction in the event of a fire. Here the emergency power supply unit controls smoke and heat extraction. The windows, smoke flaps and light domes are opened and closed by means of electric drives.

For ventilation purposes control is via vent switch, rain/wind control unit or timer, and in the event of an emergency alarm manually via RWA switch or automatically via smoke or heat differential detectors. In addition, optional alarm signals can be connected up.

Components of an RWA system (other components are optional)



- 1 = Exhaust air system: Spindle drive (E 3000), Opening and locking system (RWA 100E), Chain drive (E 740)
- 2 = Fresh air system: Retractable arm drive (K 600)
- 3 = Signal inputs: Rain/wind control
- 4 = Ventilation group: Vent switch
- 5 = Alarm group: RWA switch

GEZE RWA SYSTEMS

If the system is to be used for ventilation as well, further components will be required, such as vent switches. In the event of an alarm the windows will open up to their full opening angle. In this case the vent switches are not functional. The windows are closed via the RWA switch or by resetting the alarm in the control system. The RWA control unit takes over the control of these various functions. It supplies the system components with power and bridges power failure. The most important components and functions of the RWA central control unit are described below in more detail.

EXAMPLES OF FRESH AND EXHAUST AIR SYSTEMS

① GEZE fresh air systems



GEZE RWA AUT – TSA 160 NT



GEZE RWA AUT – Slimdrive SL



GEZE K 600

② GEZE exhaust air systems



GEZE E 740



GEZE RWA 100E



GEZE E 820/E 860



GEZE E 3000 / E 1500 N/S



GEZE SHEV

The SHEV is a certified extraction system and is made up of the following components:

- Drive with brackets
- Window profile
- Window panel
- Window fittings
- Seals

Where the building code requires a “smoke extractor”, the SHEV is a mandatory component of the RWA system. GEZE SHEVs can of course also be used for daily ventilation.

For detailed information about GEZE SHEVs please refer to the GEZE SHEV system brochure.

Selection aid for determining the right drive

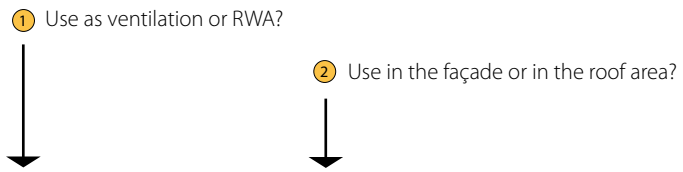

Drive	Product	Requirement		Type of use		Max. pushing and pulling force	Max. opening width
		RWA	Ventilation	Façade	Roof		
Spindle	RWA 100E	●	◐	●	○	High	High
	RWA 105E	●	◐	●	○	High	High
	RWA 110E	●	◐	●	○	High	High
	E 250	●	◐	●	●	High	High
	E 250-AB	●	◐	●	●	High	High
	E 250 VdS	●	◐	●	●	High	High
	E 1500 N	●	◐	◐	●	High	High
	E 1500 S	●	◐	◐	●	High	High
	E 3000	●	◐	○	●	High	High
	OL 350 EN	◐	●	●	○	High	High
	OL 360 EN	◐	●	●	○	High	High
	OL 370 EN	◐	●	●	○	High	High
	E350 N	◐	●	●	●	High	High
	Chain	E 740 (24 V)	●	●	●	●	High
E 820		●	◐	●	○	High	High
E 860		●	◐	●	●	High	High
E 580 (phased-out model)		◐	●	●	○	High	High
E 740 (230 V)		●	●	●	●	High	High
E 840		○	●	●	○	High	High
Scissor	E 170	◐	●	●	○	High	High
Fresh air	RWA TÖ	●	◐	●	○	High	High
	RWA K 600	●	◐	●	○	High	High
	RWA AUT	●	◐	●	○	High	High

Key:

- = suitable
- ◐ = suitable with limitations
- = not suitable

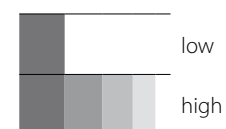

GEZE RWA SYSTEMS

Abbreviations, acronyms and explanation of terms

This section briefly explains the most important terms and definitions related to smoke and heat extraction systems:

NRA/MRA

A natural smoke extraction system is based on the “natural” effect of the thermal buoyancy principle. In contrast, the term MRA stands for a mechanical smoke extraction system.

RWA

The German abbreviation RWA stands for smoke and heat extraction system. This is made up of components that have been chosen in such a way that they act together to conduct smoke and heat so that a stable layer of warm gases is produced above cold and clean air.

SHEV

The SHEV is a naturally functioning smoke and heat extraction ventilation system. It is used to conduct smoke and hot gases out of a building in the event of fire. In accordance with EN 12101 Part 2, this product is made up of the following components:

- Drive with brackets
- if necessary, the corresponding fittings system
- Window profile
- Window glazing
- Window fittings

Smoke extraction/smoke dissipation

The term smoke extraction means the removal of smoke in the event of a fire (heat smoke removal). A stable, low-smoke layer results close to the floor which enables safe use of escape routes. In Germany, an SHEV in accordance with EN 12101-2 must be used when natural “smoke extraction” is required by the building authorities.

Smoke dissipation serves cold smoke discharge which takes place after a fire to purge the building of remaining smoke. This is a non safety-related structural product which is listed in construction regulation list C.

CE mark

The CE mark is prescribed according to EU law for certain products in connection with product safety. By applying the CE mark, the manufacturer confirms that the product complies with the pertinent European guidelines.

Abbreviations and acronyms	
a	Casement width (mm)
b	Casement height (mm)
EW	inward opening
AW	outward opening
RM	Installation on the frame
FM	Installation on the casement
F	Opening and closing force required (N)
P	Casement weight (kg)
Ü	Projection
HSK	Main closing edge
NSK	Side closing edge

GEZE ELECTRICALLY OPERATED CHAIN DRIVES

GEZE RWA exhaust systems

RWA electrically operated chain drives as direct openers



The GEZE electrically operated chain drives are electrical slimline RWA drives for the direct opening of vertically mounted, rectangular bottom, top, side and horizontally pivot hung windows, skylights and vertically pivoted windows. They are suitable for natural smoke and heat extraction as well as smoke dissipation and ventilation. The drives are fitted parallel to the window and can be matched to the corresponding window colour. They have a special chain which can transmit both pulling and pushing forces. When closed, the chain is rolled up in the drive housing and cannot be seen.



Electrically operated chain drives	E 740 (syncro)	E 740 Dual	E 820	E 860
Dimensions (H x D x L):	42 x 54 x 423 mm	42 x 63 x 1000/1600 mm	See stroke length:	See stroke length:
Stroke 100 mm	●	●	○	○
Stroke 200 mm	●	●	● 26 x 41 x 335 mm	○
Stroke 250 mm	○	○	○	● 40 x 56 x 473 mm
Stroke 300 mm	●	●	● 26 x 41 x 380 mm	○
Stroke 400 mm	●	●	● 26 x 41 x 430 mm	● 40 x 56 x 549 mm
Stroke 500 mm	○	○	● 26 x 41 x 545 mm	● 40 x 56 x 651 mm
Stroke 600 mm	○	○	● 26 x 41 x 545 mm	● 40 x 56 x 651 mm
Stroke 800 mm	○	○	● 26 x 41 x 625 mm	● 40 x 56 x 752 mm
Stroke 1000 mm	○	○	○	● 40 x 56 x 854 mm
Max. pushing/pulling force	250/300 N	500/600 N	250/250 N	600/600 N
Running speed (at 2/3 load)	7 mm/s	7 mm/s	8 mm/s for ≤ 400 mm 12 mm/s for > 400 mm	7.5 mm/s for ≤ 400 mm 9.0 mm/s for > 400 mm
End position cut-off	extended contracted	integrated path sensor Power consumption	integrated path sensor Power consumption	integrated path sensor integrated path sensor
Overload cut-off		through power consumption	through power consumption	through power consumption
Voltage	24 V DC ±25%	24 V DC ±25%	24 V DC ±25%	24 V DC ±25%
Power consumption	0.9 A (0.95 A)	1.9 A	0.7 A	1.2 A
Max. residual ripple	20%	20%	20%	20%
ON period	30%	30%	30%	30%
Ambient temperature	-5 °C to +70 °C	-5 °C to +70 °C	-5 °C to +75 °C	-5 °C to +75 °C
Enclosure rating / protection class	IP42 / III	IP42 / III	IP32 / III	IP32 / III
Cables	2 m (5 m) silicone	2 m silicone	3 m silicone	5 m silicone
Weight	approx. 1.7 kg	approx. 3.5 kg	approx. 1.4 to 1.8 kg	approx. 2.7 to 4.9 kg
Area of application	Dry rooms	Dry rooms	Dry rooms	Dry rooms

● = yes ○ = no

GEZE ELECTRICALLY OPERATED CHAIN DRIVES

GEZE chain drive E 740 / 24 V DC

Elegant direct opener with operator-friendly stroke setting

The chain drive E 740 is an electrical motor-driven solution for the opening and closing of bottom hung, top hung and side hung windows opening both inwards and outwards, skylights and light domes. The impressive features of the drive include its elegant aluminium housing and variable use: The E 3000 can be variably used for natural smoke and heat extraction and smoke dissipation as well as for ventilation. The E 740 is suitable for installation in inspected and certified SHEVs in accordance with EN 12101-2.

The high level of operating convenience is achieved through variable stroke setting via a rotary switch on the outside of the drive as well as by simple and fast installation from the front. The E 740 is available as a Solo version – for single use – and Synchro version – for the synchronised multiple use of up to four drives.

GEZE E 740



PRODUCT FEATURES

- Stroke length can be set variably to 100, 200, 300 or 400 mm through rotary switch
- All fixing parts made of metal
- Simple and fast installation from the front with the aid of an innovative chain connection
- Two-piece profile with additional interior plastic shells guarantees low-noise function as well as high protection type and class.
- Controlled by microprocessor, constant speeds independent of the casement weights
- Up to four drives can be used in synchronised version
- Projection compensation from 0 to 25 mm
- Suitable for use in tested and certified GEZE SHEVs to EN 12101-2

ORDER INFORMATION – GEZE ELECTRICALLY OPERATED CHAIN DRIVE E 740 / 24 V DC

Description	Version	Id. No.
Electrically operated chain drive E 740 / 24 V DC	EV1	112350
	white RAL 9016	112351
	to RAL	112352
Electrically operated chain drive E 740 / 24 V DC Synchro	EV1	112410
	white RAL 9016	112411
	to RAL	112412
Drive fixture skylight E 740		112360
Bracket EW E 740 RM		112355
Bracket AW E 740 RM/FM		112365
Swivel bracket EW E 740 RM		122106
Bracket set EW E 740 FM		125398
Bracket AW E 740 RM/FM Mini		133269

Accessories for GEZE electrically operated chain drives E 740



Drive fixture for skylights

GEZE drive fixture for skylights

for installation the E 740 on skylights and light domes



Bracket EW RM

GEZE bracket EW RM

for installation on the frame of bottom hung windows that open inwards



Bracket AW RM/FM

GEZE bracket AW RM/FM

for installation on the frame and casement of top hung windows that open outwards as well as skylights and light domes



Swivel bracket EW RM

GEZE swivel bracket EW RM

for installation on the frame of bottom hung windows that open inwards



Bracket set EW FM

GEZE bracket set EW FM

for installation on the casement of bottom hung and top hung windows that open inwards

Dimensional drawing RWA chain drive E 740

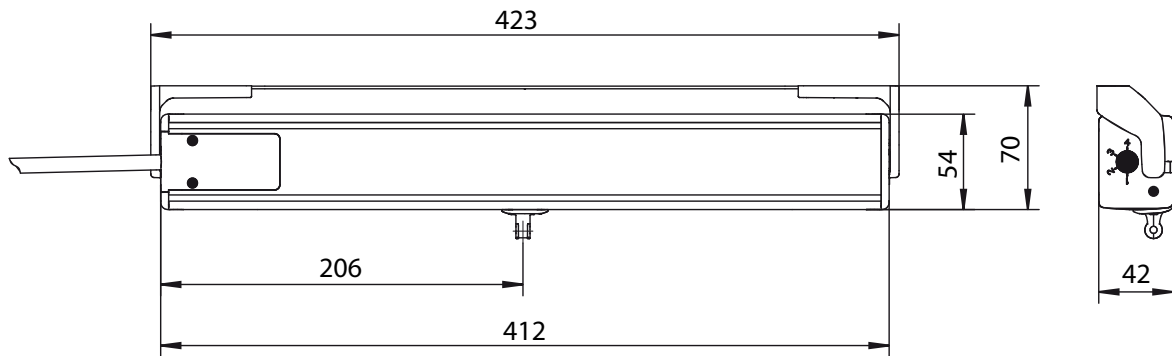

General installation possibilities

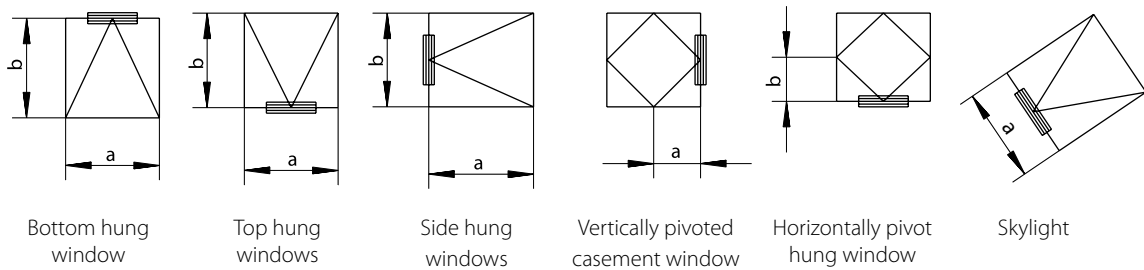

General application data

	Individual operation	Synchronous operation
Max. casement area	1.5 m ²	3 m ²
Min. casement width (a)	430 mm	950 mm
Max. casement width (a)	1200 mm	2400 mm
Projection height	0-25 mm	0-25 mm
Max. casement weight	See the respective application for the calculation equation	
Min. casement height (b)	depending on the type of installation and bracket	

- Use in casement installation with separate bracket set possible
- Use on small casement heights with separate swivel bracket possible
- With larger casement areas, an additional locking bracket is required (can only be used for bottom hung casements that are opened inwards)
- Where space is limited, the bracket AW E 740 RM/FM Mini can be used on windows that open outwards, space requirement 25 mm
- Smaller casement widths are possible, the drives then project beyond the edge of the casement

Fitting variants

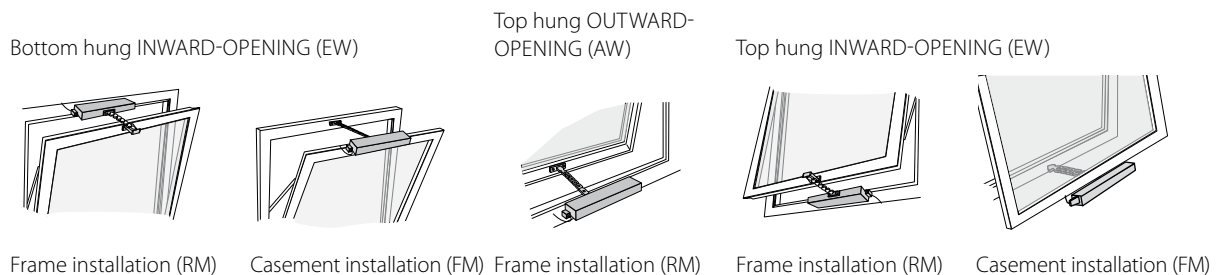

GEZE ELECTRICALLY OPERATED CHAIN DRIVES

Combination of brackets/type of installation

	Bracket	Bracket	Swivelling bracket	Bracket set	Drive fixtures	
	EW RM	AW RM/FM	EW RM	EW FM	Standard	Skylight
Bottom hung casement, inward opening	●	○	●	●	●	○
Top hung casement, outward opening	○	●	○	○	●	○
Top hung casement, inward opening	●	○	○	●	●	○
Skylight	○	●	○	○	○	●

● = yes ○ = no

RWA chain drive E 740 on bottom hung and top hung windows that open inwards and outwards

Calculation of the area of application depending on casement weight and casement dimensions

Permissible wind loads must be taken into consideration!

Equation for calculating opening and closing force:

$$F = \frac{p \times \text{stroke} \times 0.68}{b}$$

Example for E 740 in individual operation:

P = 25 kg = approx. 250 N

Stroke = 300 mm

b = 1000 mm

$$F = \frac{250 \times 300 \times 0.68}{1000} \quad \mathbf{F = 51 \text{ N}}$$

Example for two drives E 740 Syncro:

P = 150 kg = approx. 1500 N

Stroke = 300 mm

b = 1000 mm

$$F = \frac{1500 \times 300 \times 0.68}{1000} \quad \mathbf{F = 306 \text{ N}}$$

Key

F	Opening and closing force required (N)
P	Casement weight (kg)
Stroke	Casement path/drive stroke (mm)
b	Casement height (mm)

Top hung windows

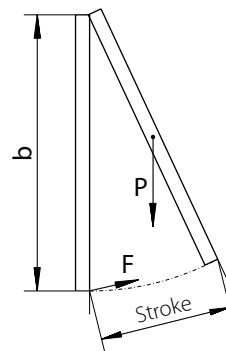

F max. = 250 N
(individual operation)
F max. = 500 N
(synchronous operation)

Bottom hung window

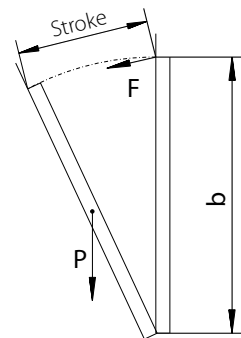

F max. = 300 N
(individual operation)
F max. = 600 N
(synchronous operation)

GEZE ELECTRICALLY OPERATED CHAIN DRIVES

Minimum casement dimensions

		Bracket	Bracket	Bracket	Swivel	Bracket set
		EW RM	AW RM/FM	AW RM/FM Mini	bracket EW RM	EW FM
Min. casement height	Stroke 100 mm	200 mm	200 mm	200 mm	○	200 mm
	Stroke 200 mm	400 mm	350 mm	350 mm	○	300 mm
	Stroke 300 mm	850 mm	500 mm	500 mm		400 mm
	Stroke 400 mm	1300 mm	650 mm	650 mm		500 mm
Min. casement width	Individual operation	430 mm	430 mm	430 mm	430 mm	430 mm
	Synchronous operation	950 mm	950 mm	950 mm	950 mm	950 mm
Projection range		0-25 mm	0-25 mm	0-25 mm	0-25 mm	0-25 mm
Min. space requirement	on the frame	58 mm	29 mm	29 mm	58 mm	30 mm
	on the casement	32 mm	35 mm	25 mm	23 mm	22 mm

○ = no

On horizontally and vertically pivot hung windows, FH corresponds to the distance from the main closing edge to the hinge axis.

Drilling pattern for bracket EW RM

For individual operation

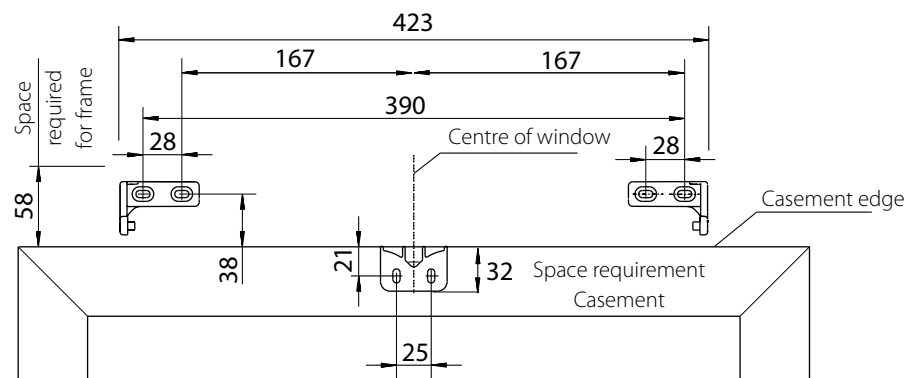

For synchronous operation

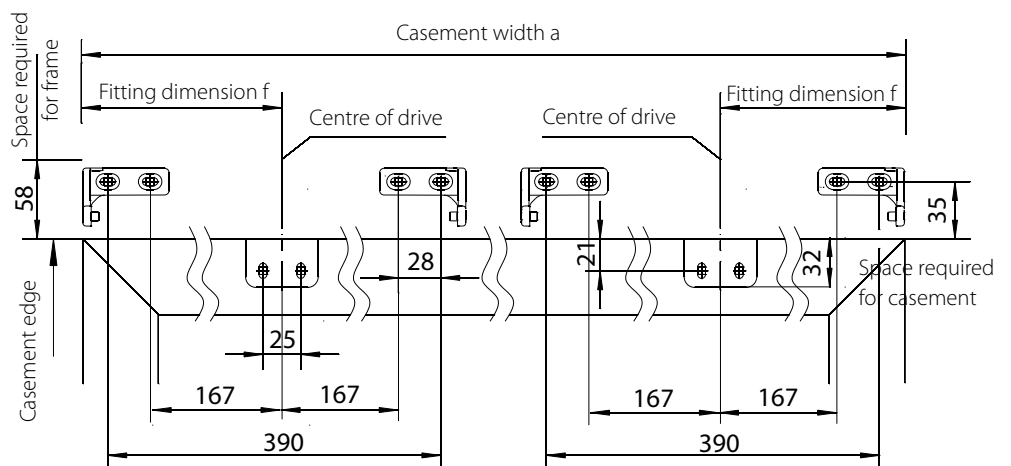

Area of application

Casement width a	Fitting dimension f
950 – 999 mm	212 mm
1000 – 2400 mm	1/4 a

GEZE ELECTRICALLY OPERATED CHAIN DRIVES

Drilling pattern for bracket AW RM/FM

For individual operation

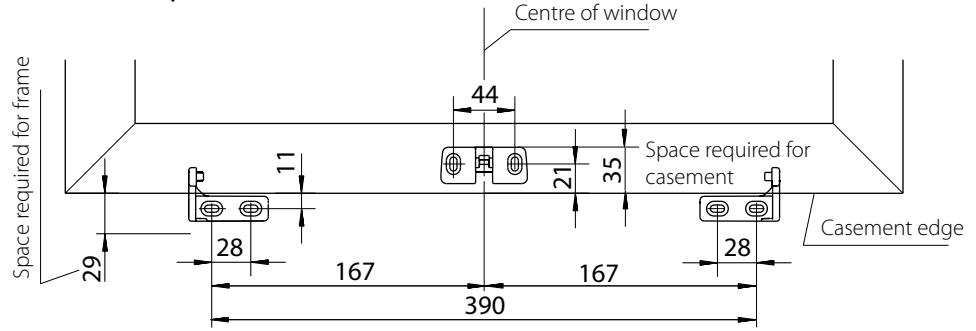

For synchronous operation

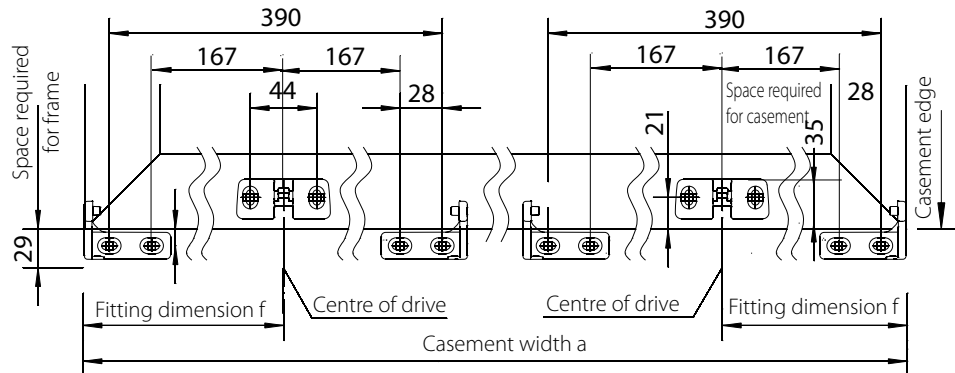

Area of application

Casement width a	Fitting dimension f
950 – 999 mm	212 mm
1000 – 2400 mm	1/4 a

Drilling pattern for swivelling bracket EW RM

For individual operation

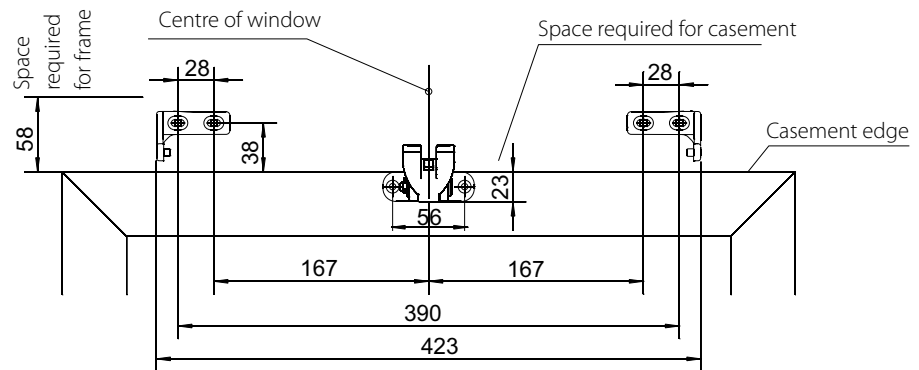

For synchronous operation

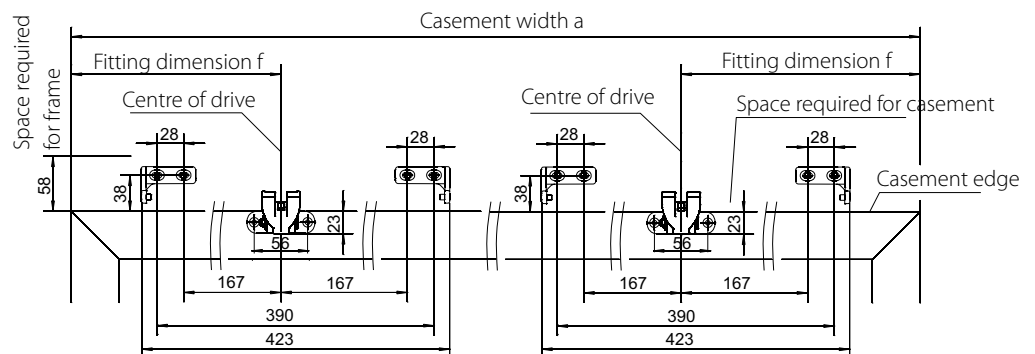

GEZE ELECTRICALLY OPERATED CHAIN DRIVES

Drilling pattern for bracket set EW RM

For individual operation

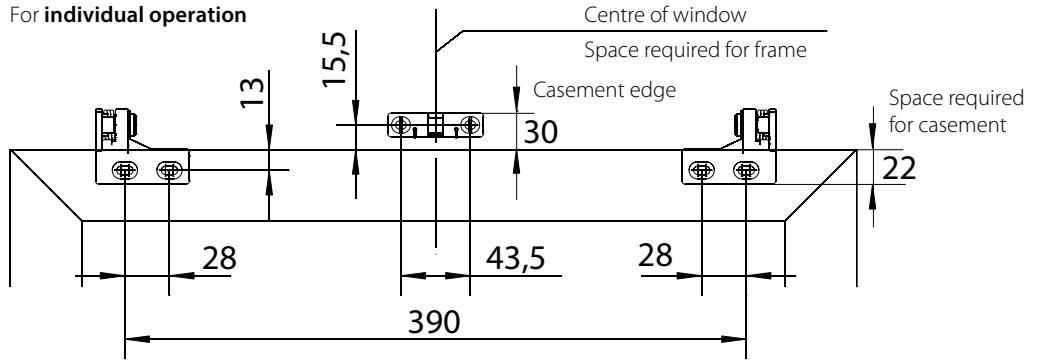

For synchronous operation

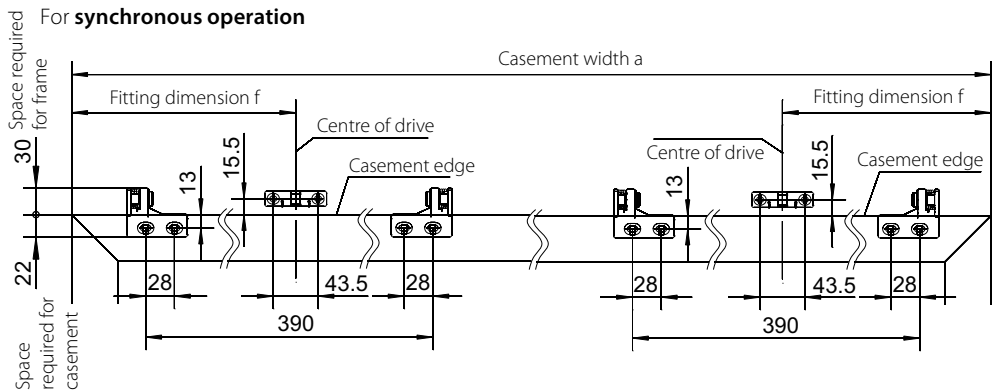

Area of application

Casement width a	Fitting dimension f
950 – 999 mm	212 mm
1000 – 2400 mm	1/4 a

Drilling pattern for bracket AW RM/FM Mini

For individual operation

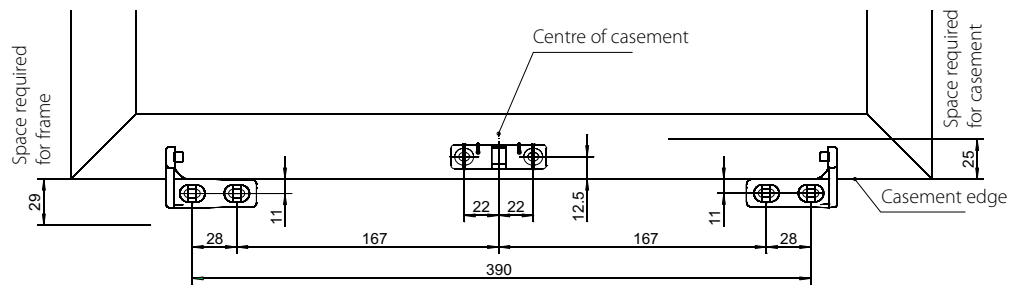

For synchronous operation

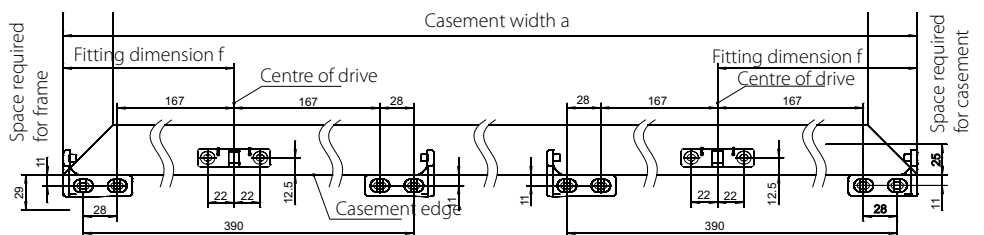

GEZE ELECTRICALLY OPERATED CHAIN DRIVES

RWA chain drive E 740 on skylight

Calculation of the area of application depending on casement weight and casement dimensions

Permissible wind loads must be taken into consideration!

Equation for calculating opening and closing force:

$$F = P \times 0.68$$

Example for E 740 in individual operation:

$$P = 25 \text{ kg} = \text{approx. } 250 \text{ N}$$

$$F = 250 \times 0.68 \quad \mathbf{F = 170 \text{ N}}$$

Example for two drives E 740 Syncro:

$$P = 60 \text{ kg} = \text{approx. } 600 \text{ N}$$

$$F = 600 \times 0.68 \quad \mathbf{F = 408 \text{ N}}$$

Key

F	Drive force required for opening (N)
P	Casement weight (kg)

Horizontal windows and light domes

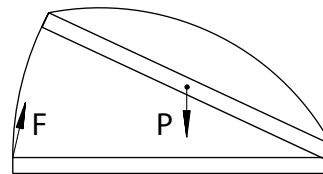

F max. = 250 N (individual operation)

F max. = 500 N (synchronous operation)

Minimum casement dimensions

		Bracket AW RM/FM
Min. casement height	Stroke 100 mm	250 mm
	Stroke 200 mm	450 mm
	Stroke 300 mm	600 mm
	Stroke 400 mm	750 mm
Min. casement width	Individual operation	450 mm
	Synchronous operation	1000 mm
Projection range		0-20 mm
Min. space requirement	on the frame	60 mm
	on the casement	42 mm

Min. casement heights depending on projection

- Min. casement height depends on projection and increases as projection increases
- Guideline values: Installation can vary depending on the type of window

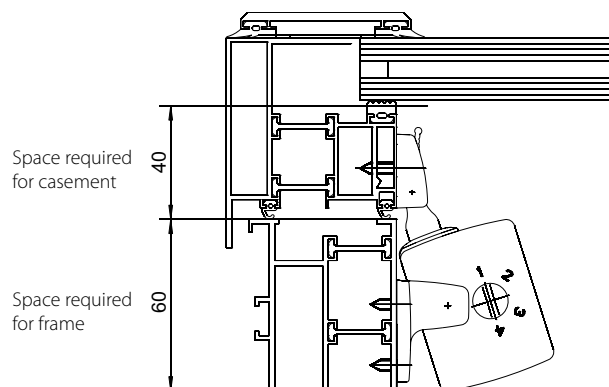
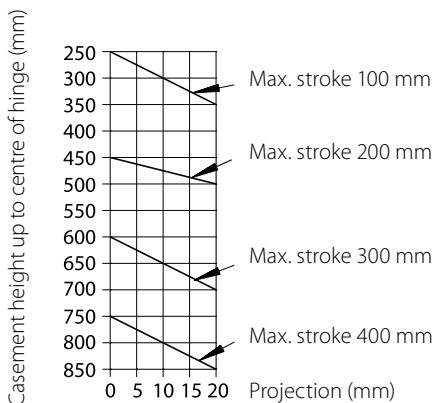

RWA chain drive E 740 on skylight

Drilling pattern for bracket AW RM/FM

For **individual operation**

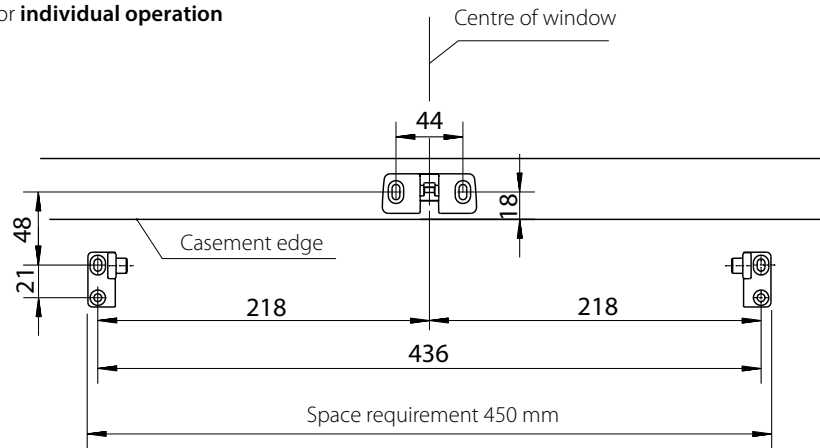

For **synchronous operation**

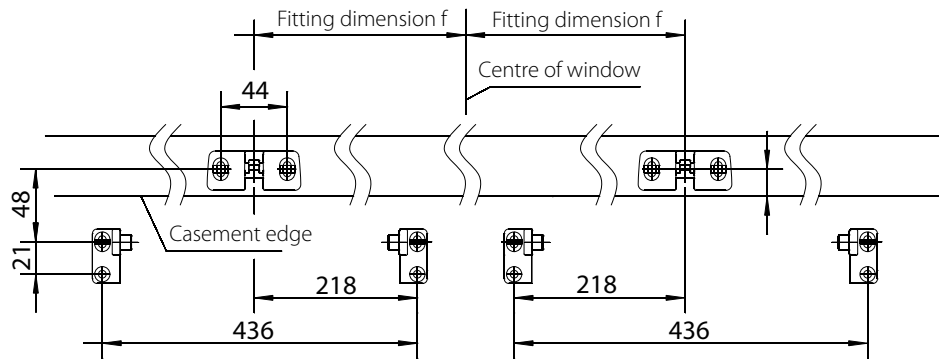

Fitting dimension $f = 1/4$ window width

GEZE ELECTRICALLY OPERATED CHAIN DRIVES

GEZE chain drive E 740 DUAL / 24 V DC

Double power in one housing – for real synchronised multiple operation

The electrically operated chain drive E 740 DUAL is made up of two drives that can be integrated inconspicuously in the building architecture in a design aluminium housing. Like the Solo variation, the E 740 DUAL was developed for use on bottom hung, top hung and side hung casements, skylights and light domes that open inwards and outwards. With twice the power, it guarantees the effortless movement of heavy windows – with the swivel bracket even on small casement heights. The real synchronised operation goes easy on window profiles and hinges, increasing their service life.

The E 740 DUAL can also be used for natural smoke and heat extraction, smoke dissipation and daily ventilation, and can be installed in inspected and certified SHEVs in accordance with EN 12101-2.

GEZE E 740 DUAL



PRODUCT FEATURES

- Variable stroke setting to 100, 200, 300 or 400 mm through rotary switch
- All fixing parts made of metal
- Simple and fast installation from the front with the aid of an innovative chain connection
- Installation times have been significantly reduced thanks to the completely pre-assembled unit
- Controlled by microprocessor, constant speeds independent of the casement weights
- Both chains run synchronously
- Two standard versions in the lengths 1000 mm and 1600 mm
Special lengths available on request
- Suitable for use in tested and certified GEZE SHEVs to EN 12101-2

ORDER INFORMATION – GEZE ELECTRICALLY OPERATED CHAIN DRIVE E 740 DUAL / 24 V DC

Description	Version	Id. No.
Electrically operated chain drive E 740 DUAL / 24 V DC	Standard version, length 1000 mm	EV1 135580
		white RAL 9016 135581
	Standard version, length 1600 mm	EV1 135582
		white RAL 9016 135583
	Special version	135584
Drive fixture skylight E 740 DUAL		135758
Bracket EW E 740 RM		112355
Bracket AW E 740 RM/FM		112365
Bracket AW E 740 RM/FM Mini		133269

Accessories for GEZE electrically operated chain drives E 740 DUAL



Drive fixture for skylights

GEZE drive fixture for skylights

for installation the E 740 on skylights and light domes



Bracket EW RM

GEZE bracket EW RM

for installation on the frame of bottom hung windows that open inwards



Bracket AW RM/FM

GEZE bracket AW RM/FM

for installation on the frame and casement of top hung windows that open outwards as well as skylights and light domes

GEZE ELECTRICALLY OPERATED CHAIN DRIVES

Dimensional drawing RWA chain drive E 740 DUAL

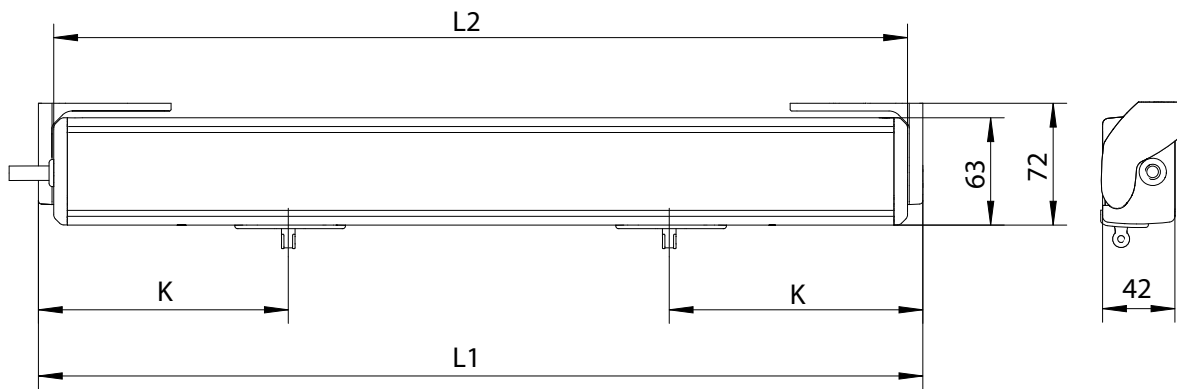

Drive length	Dimension L1	Dimension L2	Dimension L3	Dimension K	Dimension N
1000 mm	1000 mm	982 mm	1020 mm	280 mm	K + 10 mm
1600 mm	1600 mm	1582 mm	1620 mm	280 mm	K + 10 mm
Special length	min. 1000 mm max. 2000 mm	$L2 = L1 - 18 \text{ mm}$	$L3 = L1 + 20 \text{ mm}$	up to $L1 \leq 1800$: 280 mm from $L1 > 1800$: $280 + ((L1 - 1800)/2) \text{ mm}$	K + 10 mm

General installation possibilities

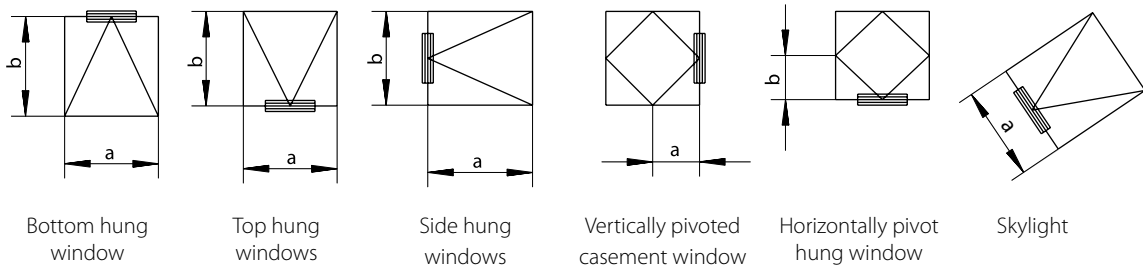

General application data	
Max. casement area	3 m ²
Min. casement width (a)	1000 mm
Max. casement width (a)	2000 mm
Projection height	0-25 mm
Max. casement weight	See the respective application for the calculation equation
Min. casement height (b)	depending on the type of installation and bracket

- Use on small casement heights with separate swivel bracket possible
- With larger casement areas, an additional locking bracket is required (can only be used for bottom hung casements that are opened inwards)
- Where space is limited, the bracket AW E 740 RM/FM Mini can be used on windows that open outwards, space requirement 25 mm
- Smaller casement widths are possible, the drives then project beyond the edge of the casement

Combination of brackets/type of installation

	Bracket	Bracket	Swivelling bracket	Drive fixtures	
	EW RM	AW RM/FM	EW FM	Standard	Skylight
Bottom hung casement, inward opening	●	○	●	●	○
Top hung casement, outward opening	○	●	○	●	○
Top hung casement, inward opening	●	○	○	●	○
Skylight	○	●	○	○	●

● = yes ○ = no

RWA chain drive E 740 DUAL on bottom hung windows that open inwards and top hung windows that open outwards

Calculation of the area of application depending on casement weight and casement dimensions

Permissible wind loads must be taken into consideration!

Equation for calculating opening and closing force:

$$F = \frac{p \times \text{stroke} \times 0.68}{b}$$

Example for two drives E 740 Syncro:

P = 150 kg = approx. 1500 N

Stroke = 300 mm

b = 1000 mm

$$F = \frac{1500 \times 300 \times 0.68}{1000} \quad \mathbf{F = 306 \text{ N}}$$

Key

F	Opening and closing force required (N)
P	Casement weight (kg)
Stroke	Casement path/drive stroke (mm)
b	Casement height (mm)

Top hung windows

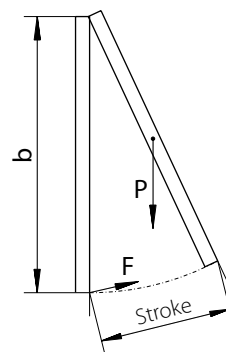

F max. = 500 N

Bottom hung window

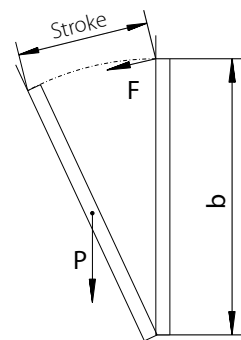

F max. = 600 N

GEZE ELECTRICALLY OPERATED CHAIN DRIVES

Drilling pattern for bracket AW RM/FM Mini

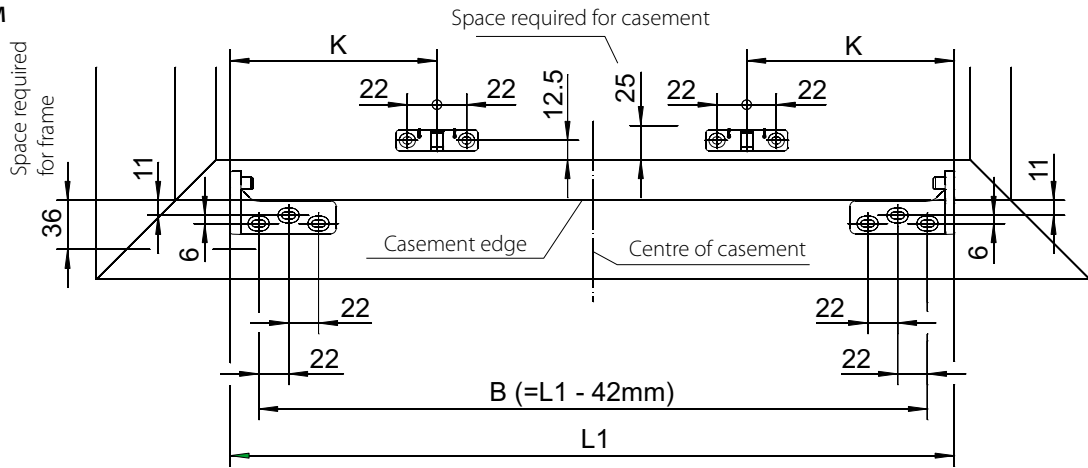

Drive length	Dimension L1	Dimension L2	Dimension L3	Dimension K	Dimension N
1000 mm	1000 mm	982 mm	1020 mm	280 mm	K + 10 mm
1600 mm	1600 mm	1582 mm	1620 mm	280 mm	K + 10 mm
Special length	min. 1000 mm max. 2000 mm	L2 = L1 - 18 mm	L3 = L1 + 20 mm	up to L1 ≤ 1800: 280 mm from L1 > 1800: 280 + ((L1 - 1800)/2) mm	K + 10 mm

GEZE ELECTRICALLY OPERATED CHAIN DRIVES

RWA chain drive E 740 DUAL on skylight

Calculation of the area of application depending on casement weight and casement dimensions

Permissible wind loads must be taken into consideration!

Equation for calculating opening and closing force:

$$F = P \times 0.68$$

Example for two drives E 740 Syncro:

$$P = 60 \text{ kg} = \text{approx. } 600 \text{ N}$$

$$F = 600 \times 0.68 \quad \mathbf{F = 408 \text{ N}}$$

Key

F	Drive force required for opening (N)
P	Casement weight (kg)

Horizontal windows and light domes

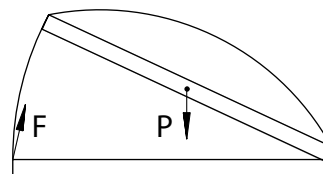

F max. = 500 N (synchronous operation)

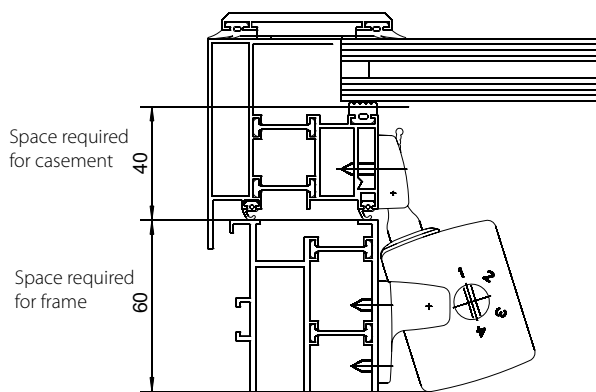

Minimum casement dimensions

	Bracket AW RM/FM	
	Stroke 100 mm	250 mm
Min. casement height	Stroke 200 mm	250 mm
	Stroke 300 mm	325 mm
	Stroke 400 mm	400 mm
Min. casement width	1000 mm	
Projection range	0-20 mm	
Min. space requirement	on the frame	68 mm
	on the casement	42 mm

Drilling pattern for bracket AW RM/FM

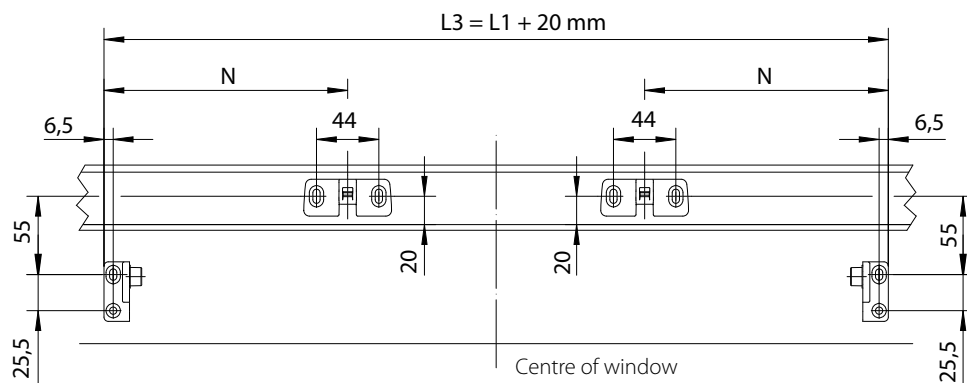

GEZE chain drive E 820 / 24 V DC

Extremely compact technology for installation flush to the profile and concealed interior fitting

The chain drive E 820 is suitable for the electrical motor-driven direct opening and closing of bottom, top and side hung windows that open inwards and outwards. It is suitable both for safe and fast smoke and heat extraction and smoke dissipation, as well as for daily ventilation. In addition, the E 820 can be installed in inspected and certified SHEVs in accordance with EN 12101-2.

In an elegant aluminium housing, the profile-flush version blends in perfectly with the building architecture, and the filigree design makes the E 820 perfectly suitable for concealed interior fitting as well.

GEZE E 820



PRODUCT FEATURES

- Suitable for mounting on the surface of the profile and concealed interior installation
- Drive controlled by microprocessor, available as Solo and Synchro variations with real synchronous control
- Synchronised multiple operation without additional module
- Electrically controlled soft start and soft stop
- High-quality stainless steel chain
- Standard stroke lengths up to 800 mm
- Suitable for use in tested and certified GEZE SHEVs to EN 12101-2

Accessories for GEZE electrically operated chain drives E 820



Drive fitting type A E 820/E 840

GEZE drive fitting type A E 820/E 840

for installation on frames and casements of bottom hung, top hung and side hung windows that open inwards and outwards



Bracket type A E 820/E 840

GEZE bracket type A E 820/E 840

combined with drive fitting type A for installation on frames and casements of bottom hung, top hung and side hung windows that open inwards and outwards

GEZE ELECTRICALLY OPERATED CHAIN DRIVES



Drive fitting type B E 820/E 840

GEZE drive fitting type B E 820/E 840

for installation on the frame of bottom hung windows that open inwards



Bracket type B E 820/E 840

GEZE bracket type B E 820/E 840

combined with drive fitting type B for frame installation on bottom hung windows that open inwards

without drive fitting for frame installation on bottom hung and top hung windows that open inwards as well as on side hung windows that open outwards

ORDER INFORMATION – GEZE ELECTRICALLY OPERATED CHAIN DRIVE E 820 / 24 V DC

Description	Version	Id. No.	Id. No.	
Electrically operated chain drive E 820 / 24 V DC			Synchro set	
	Stroke 200 mm	EV1	129640	129642
		white RAL 9016	138181	138182
		to RAL	129641	129643
	Stroke 300 mm	EV1	129650	129652
		white RAL 9016	138183	138184
		to RAL	129651	129653
	Stroke 400 mm	EV1	129660	129662
		white RAL 9016	138185	138186
		to RAL	129661	129663
	Stroke 500 mm	EV1	129670	129672
		white RAL 9016	138187	138188
		to RAL	129671	129673
	Stroke 600 mm	EV1	129680	129682
		white RAL 9016	138189	138190
		to RAL	129681	129683
	Stroke 800 mm	EV1	137709	137731
		white RAL 9016	137710	138192
		to RAL	137710	137732
	Electrically operated chain drive E 820 Synchro3 Set 24 V DC		131339	
	Electrically operated chain drive E 820 Synchro4 Set 24 V DC		131340	
	Electrically operated chain drive E 820 24 V DC special version		131341	
	Drive fixture type A E 820/E 840		129430	
	Bracket type A E 820/E 840		129675	
Drive fixture type B E 820/E 840		129676		
Bracket type B E 820/E 840		129677		

GEZE ELECTRICALLY OPERATED CHAIN DRIVES

Dimensional drawing RWA chain drive E 820

Stroke	L	LM
200 mm	335 mm	325 mm
300 mm	380 mm	370 mm
400 mm	430 mm	420 mm
500 mm	545 mm	535 mm
600 mm	545 mm	535 mm
800 mm	625 mm	615 mm

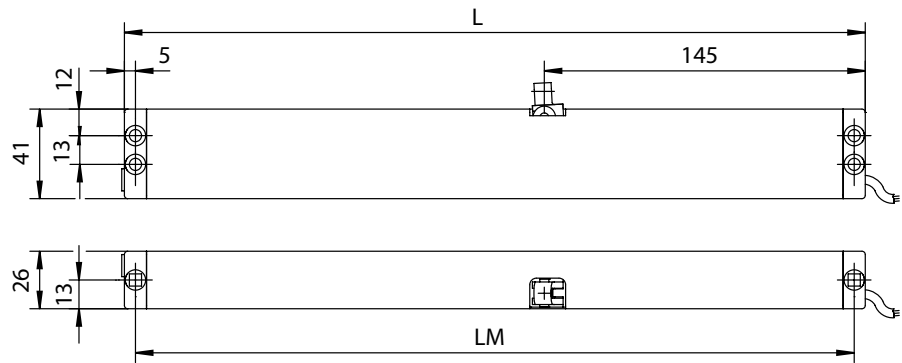

General installation possibilities

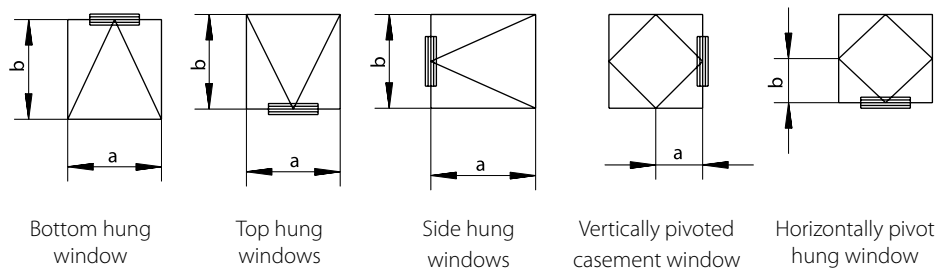

General application data		
	Individual operation	Synchronous operation
Max. casement area	1.5 m ²	3 m ²
Min. casement width (a)	Stroke 200 mm	394 mm
	Stroke 300 mm	484 mm
	Stroke 400 mm	584 mm
	Stroke 500 mm	814 mm
	Stroke 600 mm	814 mm
	Stroke 800 mm	974 mm
Max. casement width (a)	1200 mm	2400 mm
Projection height	0-21 mm	0-21 mm
Max. casement weight	See the respective application for the calculation equation	
Min. casement height (b)	depending on the type of installation and bracket	

- With larger casement areas, an additional locking bracket is required (can only be used for bottom hung casements that are opened inwards)
- Smaller casement widths are possible, the drives then project beyond the edge of the casement

Fitting variations

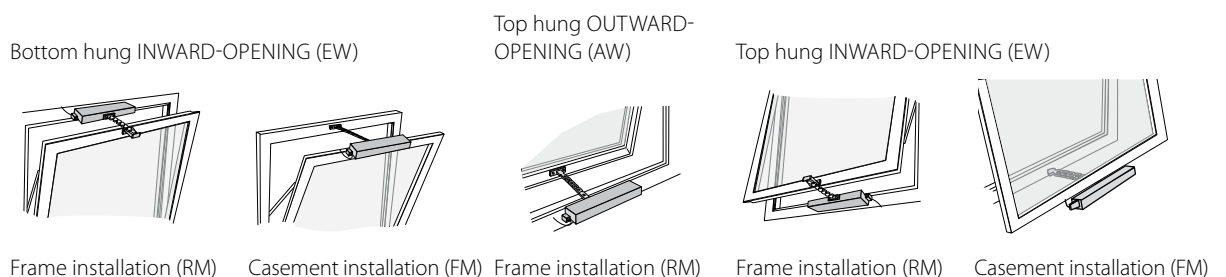

GEZE ELECTRICALLY OPERATED CHAIN DRIVES

Combination of brackets/type of installation

Bracket for	bottom hung window			top hung window			side hung window		
	INWARD-OPENING	OUTWARD-OPENING	Frame-Installation	INWARD-OPENING	OUTWARD-OPENING	Frame-Installation	INWARD-OPENING	OUTWARD-OPENING	Frame-Installation
Drive fitting type A	○	● type A	● type A	○	● type A	● type A	○	● type A	● type A
Drive fitting type B	● type B	○	○	○	○	○	○	○	○
without drive fitting	● type B	○	○	● type B	○	○	● type B	○	○

Where there are several alternatives available, selection depends on the window size, structural circumstances and chain stroke chosen.

● = yes ○ = no

RWA chain drive E 820 on bottom hung and top hung windows that open inwards and outwards

Calculation of the area of application depending on casement weight and casement dimensions

Permissible wind loads must be taken into consideration!

Equation for calculating opening and closing force:

$$F = \frac{p \times \text{stroke} \times 0.54}{b} \quad F_{\text{max.}} = 250 \text{ N per drive}$$

Example for E 820 in individual operation:

P = 25 kg = approx. 250 N
 Stroke = 400 mm
 b = 1000 mm

$$F = \frac{250 \times 400 \times 0.54}{1000} \quad F = 54 \text{ N}$$

Example for two drives E 820 Syncro:

P = 95 kg = approx. 950 N
 Stroke = 400 mm
 b = 800 mm

$$F = \frac{950 \times 400 \times 0.54}{800} \quad F = 257 \text{ N}$$

Casement panel weight:
 max. 30 kg/m² (drive cannot be swivelled)
 max. 40 kg/m² (drive can be swivelled)

Key

F	Opening and closing force required (N)
P	Casement weight (kg)
Stroke	Casement path/drive stroke (mm)
b	Casement height (mm)

Top hung windows

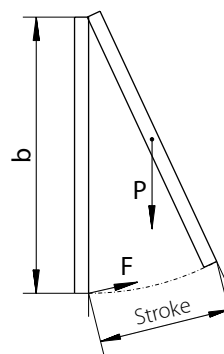

Bottom hung window

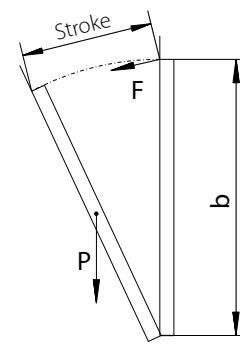

Max. pushing and pulling force depends on the drive stroke (see force-path diagram). This must be considered in the calculation

Force-path diagram

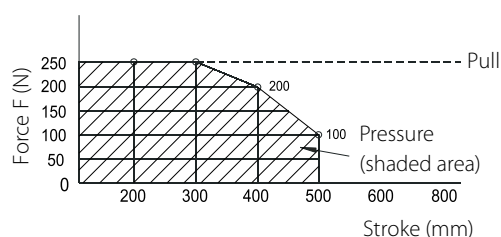

GEZE ELECTRICALLY OPERATED CHAIN DRIVES

RWA electrically operated chain drive E 820 – minimum casement heights

Depending on the type of installation and the drive fittings and brackets to be used, the following minimum casement heights can be achieved (depending on the projection (Ü))

Stroke (mm)	Bottom hung EW RM		Bottom hung/side hung EW RM		Side hung AW RM		Bottom hung/side hung EW FM		Bottom hung/side hung EW FM		Top hung EW RM		Top hung AW RM		Top hung AW RM		Top hung EW FM		Top hung EW FM	
	D		C		B		A		A		C		A		B		A		B	
Ü (mm)	≤10	≤21	≤10	≤21	≤10	≤21	≤10	≤21	≤10	≤21	≤10	≤21	≤10	≤21	≤10	≤21	≤10	≤21	≤10	≤21
200	250	275	425	475	325	360	325	360	325	360	425	475	400	450	350	400	350	400	400	450
300	325	360	500	550	450	500	500	550	450	500	500	550	500	550	400	450	400	450	500	550
400	400	450	600	650	550	600	750	800	550	600	600	650	700	750	450	500	450	500	700	750
500	500	550	775	825	675	725	975	1025	675	725	700	750	800	850	600	650	600	650	800	850
600	600	650	950	1000	800	850	1200	1250	800	850	○	○	○	○	○	○	○	○	○	○
800	800	850	1250	1300	1080	1130	1600	1650	1080	1130	○	○	○	○	○	○	○	○	○	○

● = yes ○ = no

Minimum casement heights are applicable for bottom, top and side hung windows. On horizontally and vertically pivot hung windows, FH corresponds to the distance from the main closing edge to the hinge axis. For the assignment of A, B, C and D see the following fitting dimensions.

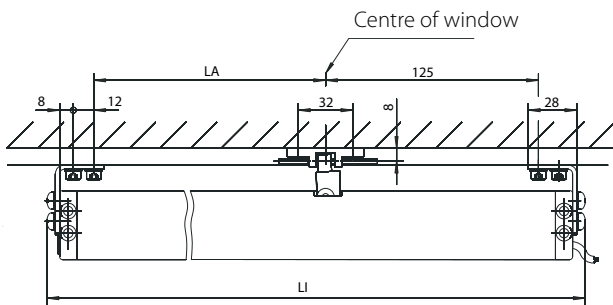

Fitting dimensions drive fitting type A with bracket type A

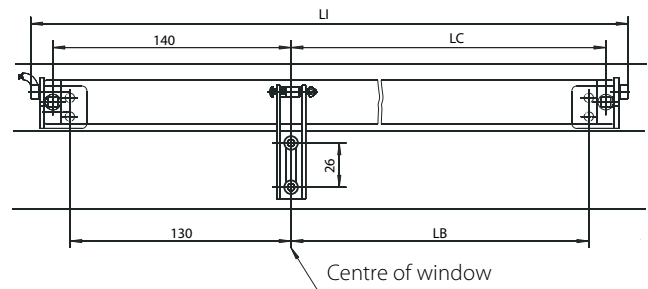

Fitting dimensions drive fitting type A with bracket type A

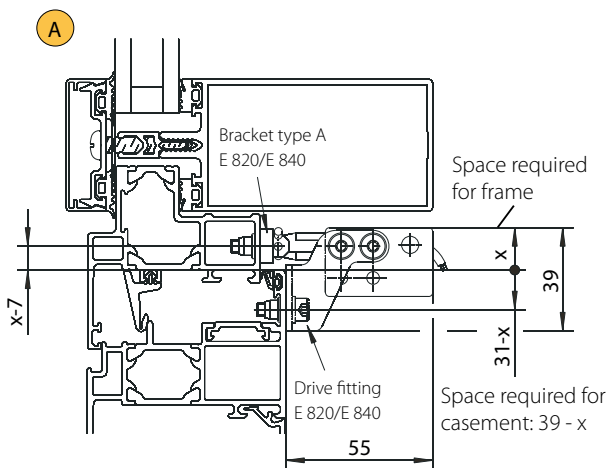

Drive standard installation
Example: Casement installation on bottom hung window that opens inwards

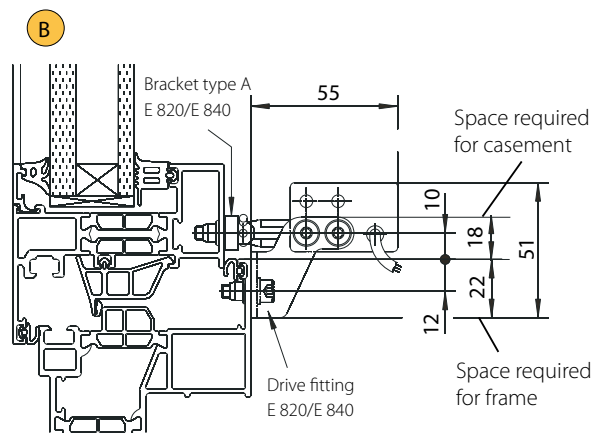

Drive turned
Example: Frame installation on top hung window that opens outwards

GEZE ELECTRICALLY OPERATED CHAIN DRIVES

Fitting dimensions without drive fitting with bracket type B

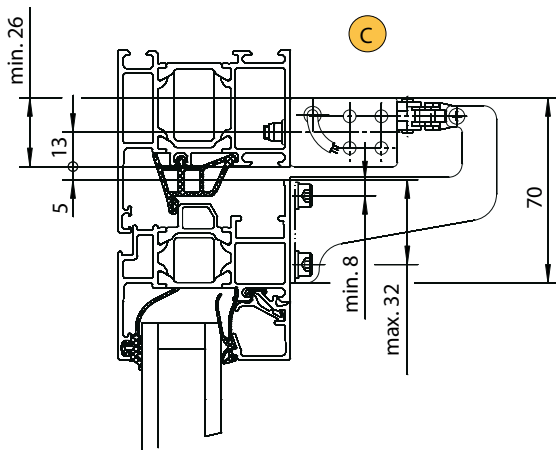

Drive directly on the frame
 Example: Frame installation on bottom hung window that opens inwards

Fitting dimensions drive fitting type B with bracket type B

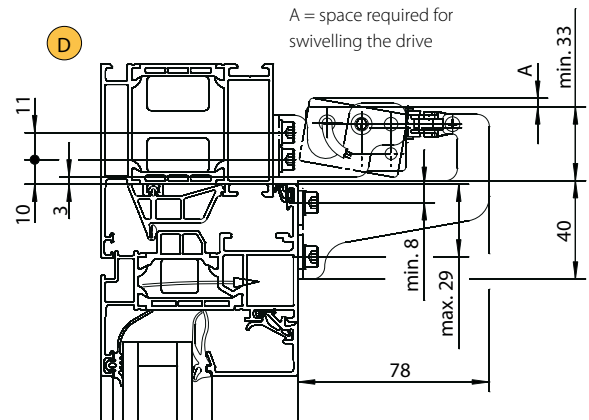

Drive can be swivelled
 Example: Frame installation on bottom hung window that opens inwards

Lengths depend on drive stroke

Stroke	LA	LB	LC	LI
200 mm	170 mm	174 mm	185 mm	349 mm
300 mm	215 mm	219 mm	230 mm	394 mm
400 mm	265 mm	269 mm	280 mm	444 mm
500 mm	380 mm	384 mm	395 mm	559 mm
600 mm	380 mm	384 mm	395 mm	559 mm
800 mm	460 mm	466 mm	475 mm	639 mm

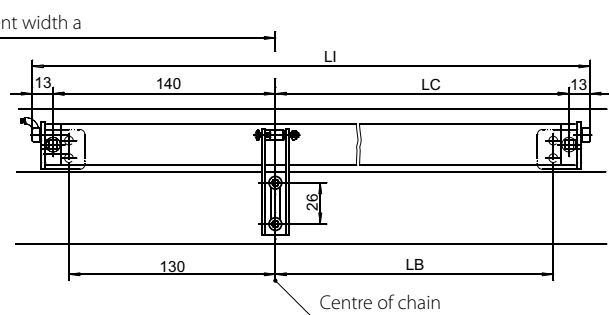
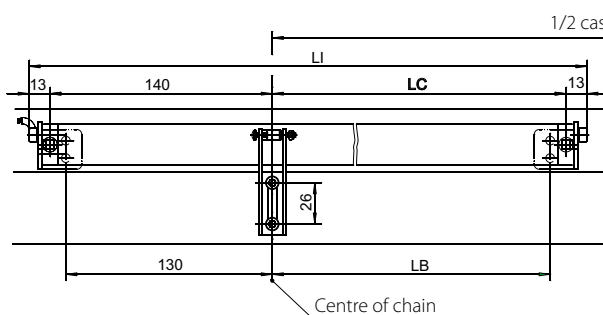
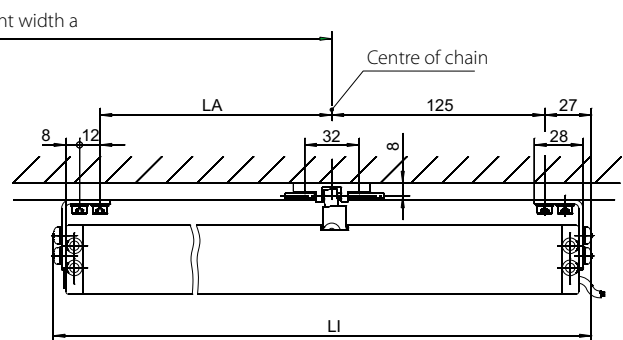
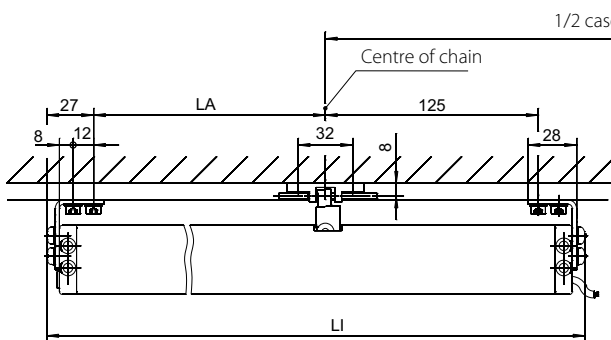

GEZE ELECTRICALLY OPERATED CHAIN DRIVES

GEZE chain drive E 860 / 24 V DC

Technically mature, powerful solution for installation on main and side closing edges

In an aluminium housing as stylish as it is full of refined technical details, the E 860 is a perfect solution for safe and fast smoke and heat extraction, smoke dissipation and daily ventilation operation.

It ensures electrically motor-drive direct opening and closing of bottom hung, top hung and side hung casements that open inwards and outwards as well as skylights and light domes. It can be installed both on main and side closing edges and is also suitable for installation in inspected and certified SHEVs in accordance with EN 12101-2.

GEZE E 860



PRODUCT FEATURES

- Suitable for installation on main and side closing edges
- Drive controlled by microprocessor, available as Solo and Synchro variations with real synchronous control
- Synchronised multiple operation without additional module
- Electrically controlled soft start and soft stop
- High-quality stainless steel chain
- Standard stroke lengths up to 1000 mm (larger stroke length on request)
- Suitable for use in tested and certified GEZE SHEVs to EN 12101-2

References



Parish hall Heuchlingen, Germany

GEZE ELECTRICALLY OPERATED CHAIN DRIVES

ORDER INFORMATION – GEZE ELECTRICALLY OPERATED CHAIN DRIVE E 860 / 24 V DC

Description	Version	Id. No.	Id. No.
			Synchro set
	EV1	129685	129687
Stroke 250 mm	white RAL 9016	138199	138201
	to RAL	129686	129688
Stroke 400 mm	EV1	129690	129692
	white RAL 9016	138203	138205
Stroke 500 mm	to RAL	129691	129693
	EV1	129695	129697
Stroke 600 mm	white RAL 9016	138207	138209
	to RAL	129696	129698
Stroke 800 mm	EV1	129700	129702
	white RAL 9016	138211	138213
Stroke 1000 mm	to RAL	129701	129703
	EV1	129705	129707
Stroke 1500 mm	white RAL 9016	138227	138229
	to RAL	129706	129708
Stroke 250 mm	EV1	129710	129712
	white RAL 9016	138231	138233
Stroke 400 mm	to RAL	129711	129713
	EV1	129715	129717
Stroke 500 mm	white RAL 9016	138235	138237
	to RAL	129716	129718
Stroke 600 mm	EV1	130587	130588
	Stroke 400 mm	EV1	130592
Stroke 500 mm	EV1	130597	130598
	Stroke 600 mm	EV1	130602
Stroke 800 mm	EV1	130607	130608
	Stroke 1000 mm	EV1	130612
Stroke 1500 mm	EV1	130617	130618
	Stroke 250 mm		
Electrically operated chain drive E 860 / 24 V DC MK (MK = status contact)			
Stroke 400 mm			
Stroke 500 mm			
Stroke 600 mm			
Stroke 800 mm			
Stroke 1000 mm			
Stroke 1500 mm			
Electrically operated chain drive E 860 Synchro3 Set		129724	
Electrically operated chain drive E 860 Synchro4 Set		129909	
Electrically operated chain drive E 860 special version		130454	
Bracket type A E 860		129723	
Bracket type B E 860		129725	
Bracket type C E 860		129726	
Bracket set E 860 FM		129727	
Washer for bracket set E 860 FM		129728	
Drive fitting type 1 E 860		129729	
Drive fitting type 2 E 860		129730	
Drive fitting type 3 E 860		130221	
Drive fitting type 4 E 860		130522	
Drive fitting for skylight E 860		129867	
Bracket RS 106 D E 860		129868	

Accessories for GEZE electrically operated chain drives E 860



Bracket type A E 860

GEZE bracket E 860 type A

for installation on frames and casements of bottom hung, top hung, side hung windows that open inwards and outwards, and horizontally and vertically pivot hung windows



Bracket type B E 860

GEZE bracket E 860 type B

for installation on frames and casements of bottom hung, top hung, side hung windows that open inwards and outwards, and horizontally and vertically pivot hung windows



Bracket type C E 860

GEZE bracket E 860 type C

for installation on frames on bottom hung, top hung, side hung that open inwards and outwards, and horizontally and vertically pivot hung windows



Bracket set E 860 FM

GEZE bracket set E 860 FM

for installation on the casement of bottom hung windows that open inwards and horizontally pivot hung windows



Washers for bracket set E 860 FM

GEZE washer for bracket set E 860 FM

Washers for the bracket set E 860 FM with projection < 10 mm

Accessories for GEZE electrically operated chain drives E 860



Drive fitting type 1 E 860

GEZE drive fitting type 1 E 860

for installation on frames and casements of bottom hung, top hung, side hung windows that open inwards and outwards, and horizontally and vertically pivot hung windows



Drive fitting type 2 E 860

GEZE drive fitting type 2 E 860

for installation on frames and casements of bottom hung, top hung, side hung windows that open inwards and outwards, and horizontally and vertically pivot hung windows



Drive fitting type 3 E 860

GEZE drive fitting type 3 E 860

for installation on frames and casements of bottom hung, top hung, side hung windows that open inwards and outwards, and horizontally and vertically pivot hung windows



Drive fitting type 4 E 860

GEZE drive fitting type 4 E 860

for installation on frames of bottom hung and top hung windows that open outwards as well as skylights and light domes

Dimensional drawing RWA chain drive E 860

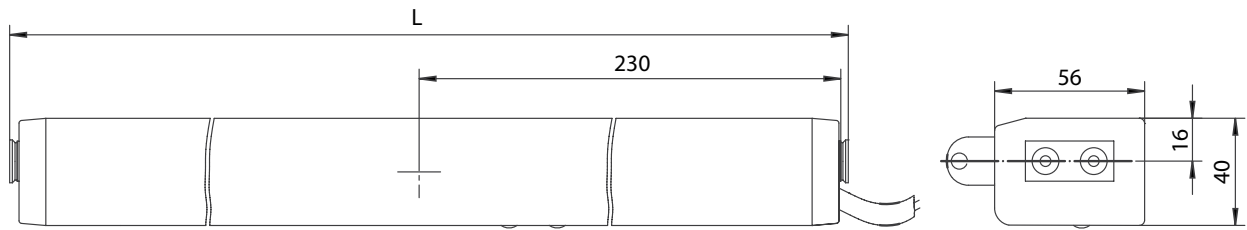

General installation possibilities

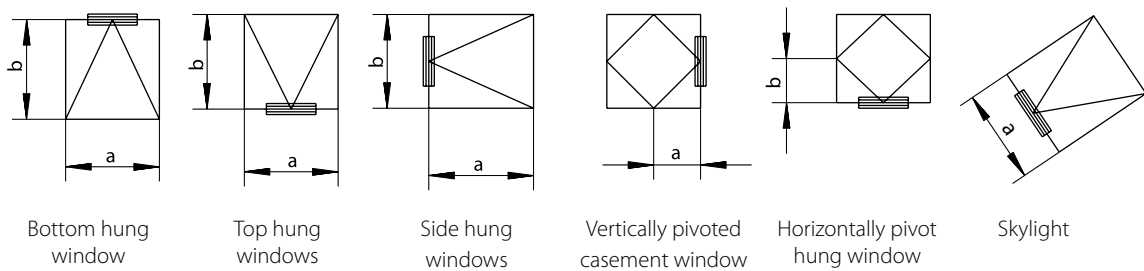

General application data		Individual operation	Synchronous operation
Max. casement area		1.5 m ²	3 m ²
Min. casement width (a)	Stroke 250 mm	474 mm	950 mm
	Stroke 400 mm	626 mm	1050 mm
	Stroke 500 mm	830 mm	1200 mm
	Stroke 600 mm	830 mm	1400 mm
	Stroke 800 mm	1032 mm	1400 mm
	Stroke 1000 mm	1236 mm	1800 mm
Max. casement width (a)		1200 mm	2400 mm
Projection height		0-21 mm	0-21 mm
Max. casement weight		See the respective application for the calculation equation	
Min. casement height (b)		depending on the type of installation and bracket	

- With larger casement areas, an additional locking bracket is required (can only be used for bottom hung casements that are opened inwards)
- Smaller casement widths are possible, the drives then project beyond the edge of the casement

Fitting variations

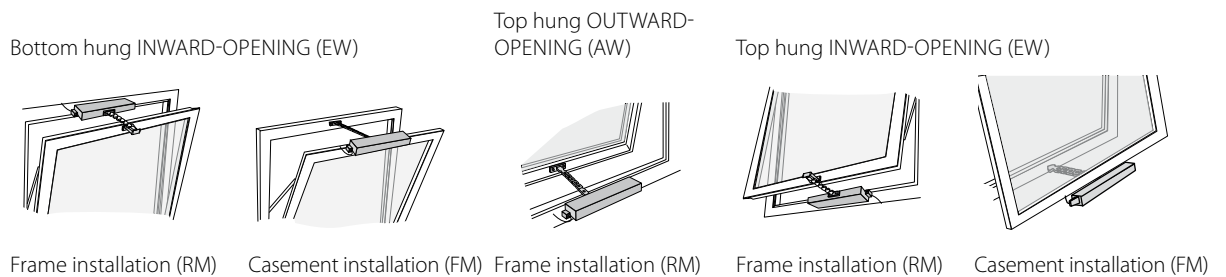

GEZE ELECTRICALLY OPERATED CHAIN DRIVES

Combination of brackets/type of installation

Bracket for	bottom hung window			Top hung window			Side hung window		
	INWARD-OPENING Frame-Installation	OUTWARD-OPENING Frame-Installation	Case ment Installation	INWARD-OPENING Frame-Installation	OUTWARD-OPENING Frame-Installation	Case ment Installation	INWARD-OPENING Frame-Installation	OUTWARD-OPENING Frame-Installation	Case ment Installation
Drive fitting type 1	○	● type A	● type A	○	● type A	● type A	○	● type A	● type A
Drive fitting type 2	○	● type A ● type B	● type A	○	● type A ● type B	● type A ● type B	○	● type A ● type B	● type A ● type B
Drive fitting type 3	● type C	● type A ● type B	○	● type C	● type A ● type B	○	● type C	○	○
Drive fitting type 4	○	● type A ● type B	○	○	● type A ● type B	○	○	○	○
Bracket set FM	○	○	●	○	○	○	○	○	○

Bracket for	Vertically pivoted window			Horizontally pivoted window		
	INWARD-OPENING Frame-Installation	OUTWARD-OPENING Frame-Installation	Case ment Installation	INWARD-OPENING Frame-Installation	OUTWARD-OPENING Frame-Installation	Case ment Installation
Drive fitting type 1	○	● type A	● type A	○	● type A	● type A
Drive fitting type 2	○	● type A ● type B	● type A	○	● type A ● type B	● type A
Drive fitting type 3	● type C	○	○	● type C	○	○
Drive fitting type 4	○	○	○	○	○	○
Bracket set FM	○	○	○	○	○	●

Where there are several alternatives available, selection depends on the window size, structural circumstances and chain stroke chosen.

● = yes ○ = no

ORDER INFORMATION – BRACKETS AND CONSOLES FOR SKYLIGHT INSTALLATION

Description	Version	Id. No.
Drive fitting for skylight E 860	Stainless steel	129867
Drive fitting for skylight short E 860	Stainless steel	137170
Skylight bracket type A E 860	Stainless steel	129868
Skylight bracket type H E 860	Stainless steel	136630
Skylight bracket set type S E 860	Stainless steel	136486

Skylight order requirements (further profile systems on request):

Schüco AWS 57 RO: Skylight bracket set type S (Id no. 136486)

Wicona Wictec 50: Drive fitting type 2 (Id No. 129730) + bracket type B (Id no. 129725)

Alcoa AA 100: Drive fitting for skylight (Id No. 129867) + bracket type A (Id no. 129723) + roof bracket type A (Id no. 129868)

Heraol 085 D: Drive fitting for short skylight (Id No. 137170) + bracket type B (Id no. 129725) + roof bracket type H (Id no. 136630)

Hueck 85 E: Drive fitting type 2 (Id No. 129730) + bracket type B (Id no. 129725)

GEZE ELECTRICALLY OPERATED CHAIN DRIVES

Calculation of the area of application for the electrically operated chain drive E 860 depending on casement weight and casement dimensions

Permissible wind loads must be taken into consideration!

Equation for calculating opening and closing force:

$$F = \frac{p \times \text{stroke} \times 0.54}{b}$$

Example for E 860 in individual operation:

P = 50 kg = approx. 500 N

Stroke = 600 mm

b = 1000 mm

$$F = \frac{500 \times 600 \times 0.54}{1000} \quad \mathbf{F = 162 \text{ N}}$$

Example for two drives E 860 Syncro:

P = 150 kg = approx. 1500 N

Stroke = 600 mm

b = 1000 mm

$$F = \frac{1500 \times 600 \times 0.54}{1000} \quad \mathbf{F = 486 \text{ N}}$$

Key

F	Opening and closing force required (N)
P	Casement weight (kg)
Stroke	Casement path/drive stroke (mm)
b	Casement height (mm)

Top hung windows

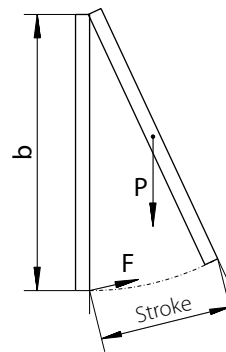

Bottom hung window

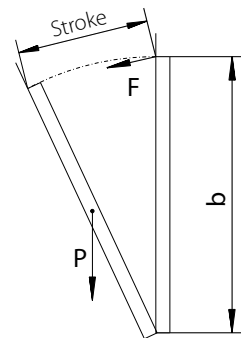

Equation for calculating opening and closing force:

$$F = P \times 0.54$$

Example for E 860 in individual operation:

P = 35 kg = approx. 350 N

$$F = 350 \times 0.54 \quad \mathbf{F = 189 \text{ N}}$$

Example for two drives E 860 Syncro:

P = 100 kg = approx. 1000 N

$$F = 1000 \times 0.54 \quad \mathbf{F = 540 \text{ N}}$$

Horizontal windows and light domes

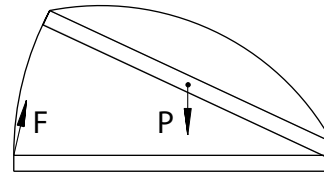

F max. = 600 N (Solo operation)

F max. = 1200 N (synchronous operation)

Max. pushing and pulling force depends on the drive stroke (see force-path diagram). This must be considered in the calculation

Force-path diagram with lowering and lifting load

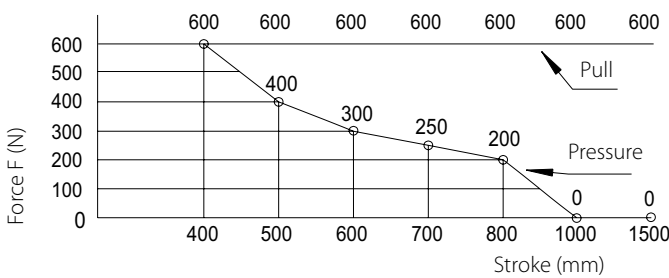

GEZE ELECTRICALLY OPERATED CHAIN DRIVES

RWA electrically operated chain drive E 860 – minimum casement heights

Depending on the type of installation and the drive fittings and brackets to be used, the following minimum casement heights can be achieved (depending on the projection (Ü))

Stroke (mm)	Drive fitting type 1 A				Drive fitting type 2 Dimension x = 35 mm B				Drive fitting type 2 Dimension x = 51 mm B				Drive fitting type 3 + bracket type C C				Bracket set FM		
	0	8	16	21	0	8	16	21	0	8	16	21	0	8	16	21	0	10	21
250	900	900	1000	1000	500	550	550	650	200	200	200	250	350	350	400	400	500	350	375
400	1600	1600	1700	1700	1000	1150	1200	1300	400	400	450	500	700	700	800	800	800	500	600
500	2100	2100	2200	2200	1100	1300	1300	1350	500	500	600	600	900	900	1000	1000	1000	650	750
600	2500	2500	○	○	1250	1500	1600	1700	600	650	700	750	1200	1200	1300	1300	1200	800	900
800	○	○	○	○	1700	2100	2200	2350	800	850	950	1000	1600	1600	1700	1700	1600	1050	1200
1000	○	○	○	○	2150	2600	2800	3000	1000	1050	1150	1200	2000	2000	2100	2100	2000	1300	1500

○ = no

The minimum casement height for top hung windows that open outwards is 400 mm (drive fitting type 2) or 800 mm (drive fitting type 1). Minimum casement heights are applicable for bottom, top and side hung windows. On horizontally and vertically pivot hung windows, FH corresponds to the distance from the main closing edge to the hinge axis. For the assignment of A, B and C see the following fitting dimensions.

Fitting dimensions drive fitting type 1 with bracket type A

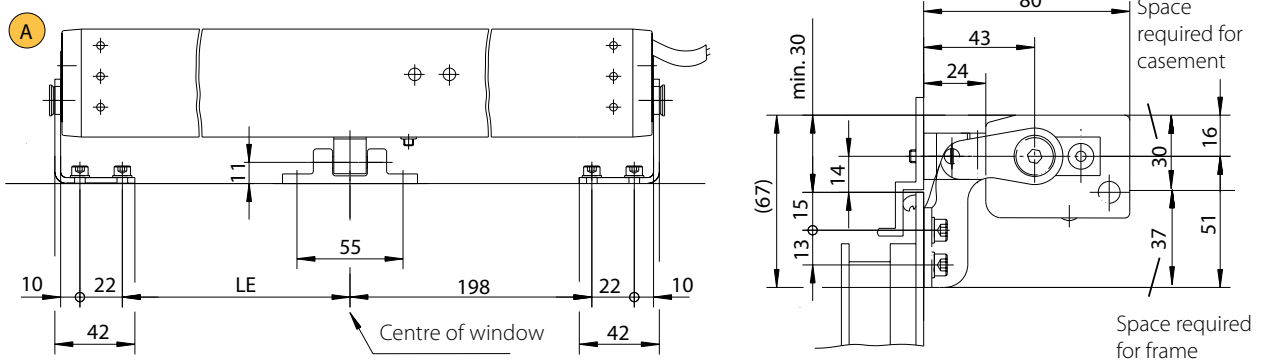

Fitting dimensions drive fitting type 2 with bracket type A

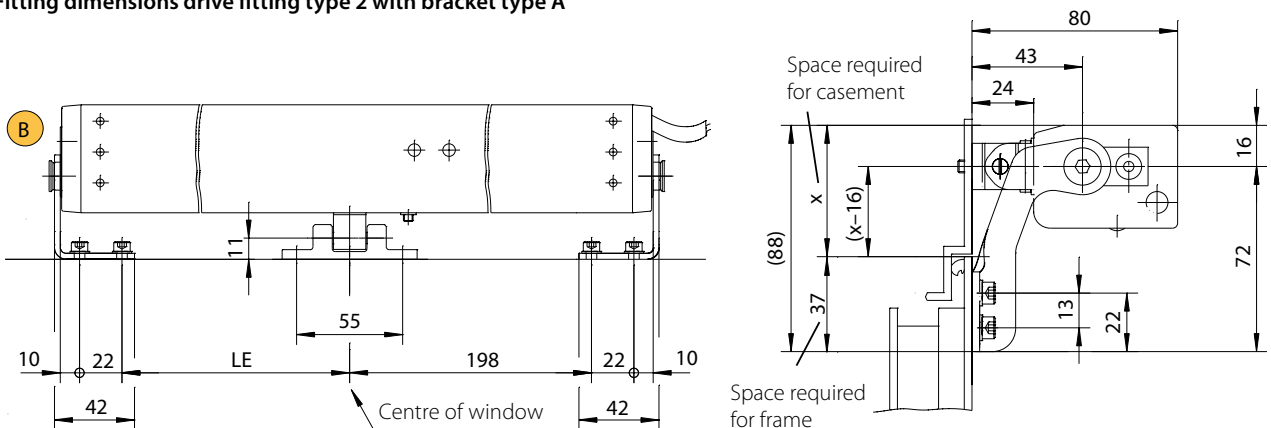

Fitting dimensions drive fitting type 3 with bracket type C

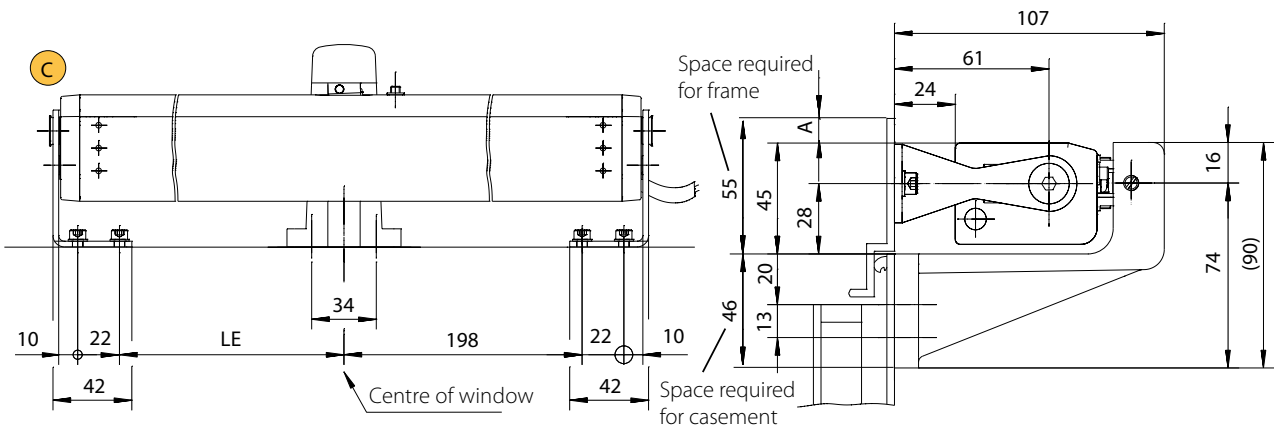

In the case of frame installation, take drive swivelling range A into account!

Fitting dimensions drive fitting type 4 with bracket type A

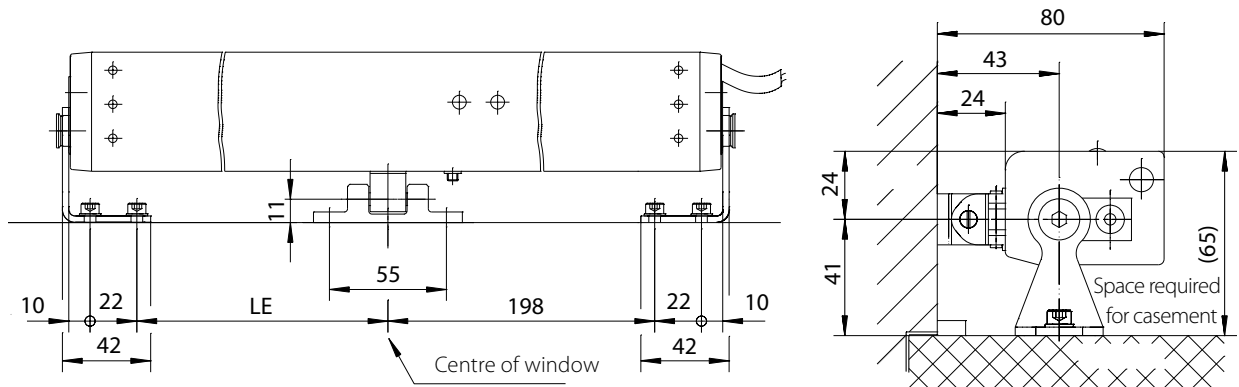

Fitting dimensions bracket set E 860 FM

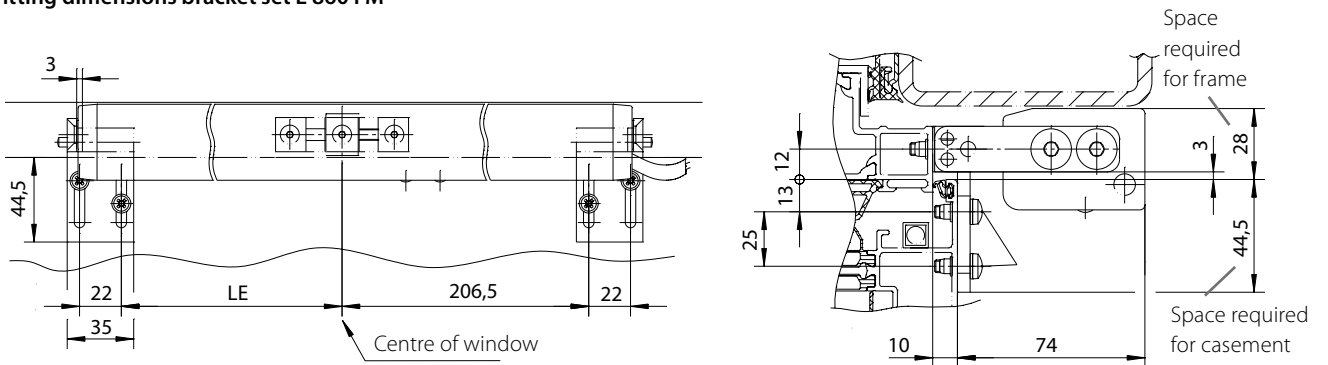

Baseplates required for projection ≤ 10 mm!

GEZE ELECTRICALLY OPERATED CHAIN DRIVES

Mechanical locking bracket for GEZE electrically operated chain drives

For windows with large casement areas, it is often not sufficient to lock the casement using the drive alone. As a solution for such cases, GEZE offers the possibility of using an additional mechanically operated locking bracket.

The additional locking bracket is easy to install. It is also very inexpensive since it is operated mechanically and thus improves the window sealing and provides better protection against intruders. It is suitable for use with all GEZE electrically operated chain drives E 740 and E8x0 on common profile systems and vertically installed bottom, top or side hung function.

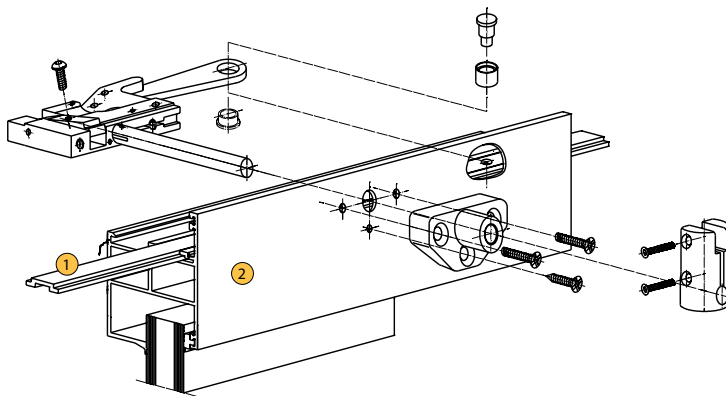

- ① Driving rod of the locking mechanism (fitting side)
- ② Casement

PRODUCT ADVANTAGES

- No additional follow-up control required
- No additional cables necessary since locking takes place mechanically
- Simple installation using template

FUNCTION

- When the chain drive extends or retracts, the window casement is locked or unlocked mechanically, with the mechanism concealed in an internal central locking device.
- The concealed all-round locking in the window casement is effected when the casement bracket engages the driving rod and thus latches the locking components.

ORDER INFORMATION – GEZE LOCKING BRACKETS FOR ELECTRICALLY OPERATED CHAIN DRIVES

Description	Version	Id. No.
Locking bracket E 740	Stroke 15 mm EV1	125399
	to RAL	125403
Locking bracket set E 740 Synchro/Dual	Stroke 18 mm EV1	125400
	to RAL	125404
Locking bracket set E 740 Synchro/Dual		135803
Locking bracket E 820/E 840	Stroke 15 mm EV1	124367
	to RAL	134368
Locking bracket set E 820/E 840 Synchro/Dual	Stroke 18 mm EV1	134369
	to RAL	134370
Locking bracket set E 820/E 840 Synchro/Dual		135804
Locking bracket E 860	Stroke 15 mm EV1	134323
	to RAL	134324
Locking bracket set E 860 Synchro/Dual	Stroke 18 mm EV1	134325
	to RAL	134326
Locking bracket set E 860 Synchro/Dual		135805

GEZE ELECTRICALLY OPERATED CHAIN DRIVES

General application data

- The stroke of the locking mechanism required for locking must not exceed 15 mm or 18 mm.
The respective locking bracket must be used according to stroke 15 mm or 18 mm.
- The larger the number of locking points and length of driving rod, the greater the force required for locking and unlocking.

For standard setting of the locking elements, the following is recommended per chain drive:

Electrically operated chain drive E 740 max. 4 locking points for aluminium, plastic and wooden windows

Electrically operated chain drive E 820 max. 2 locking points for aluminium, plastic and wooden windows

Electrically operated chain drive E 860 max. 6 locking points for aluminium windows

max. 4 locking points for plastic and wooden windows

- All drives: Space required for casement: 36 mm

Mechanical locking bracket

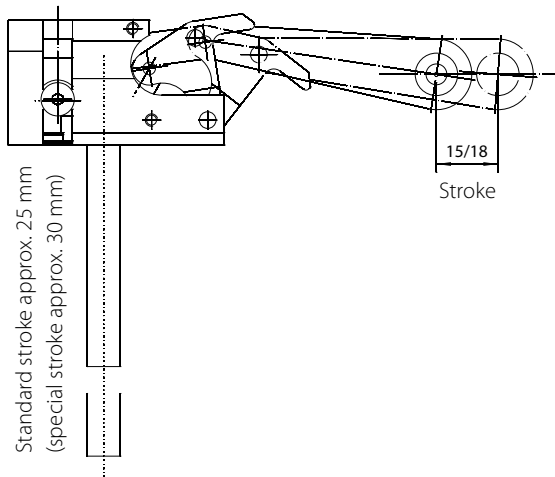

Fitting dimensions E 740

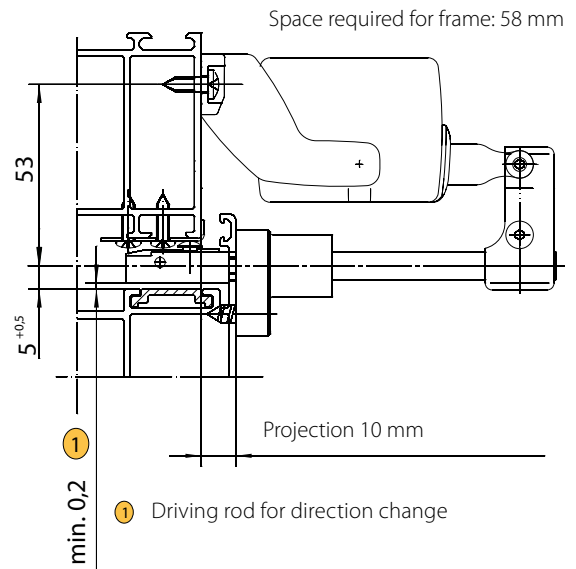

Fitting dimensions E 820/E 840

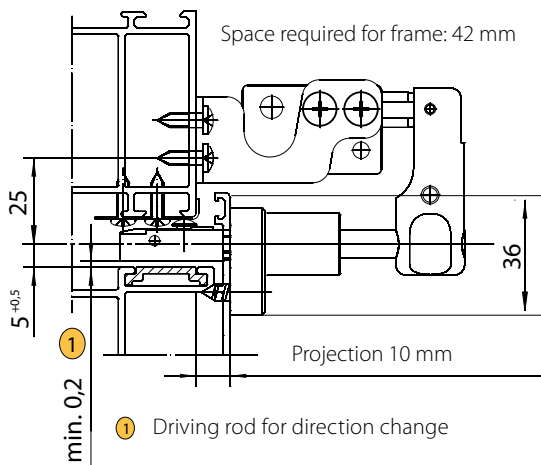

Fitting dimensions E 860

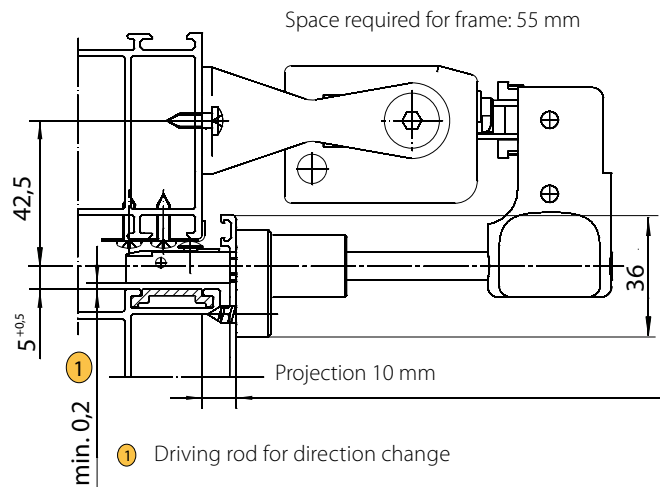

GEZE ELECTRICALLY OPERATED CHAIN DRIVES

Front view of locking bracket E 740

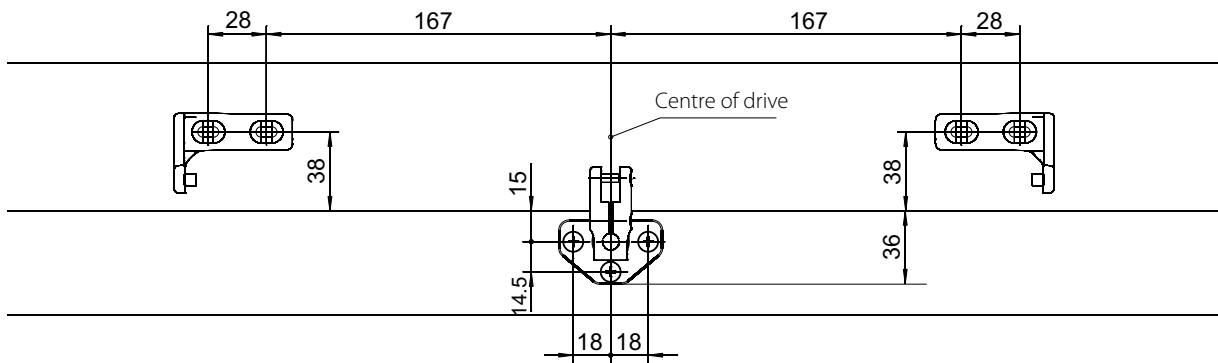

Front view of locking bracket E 820/840

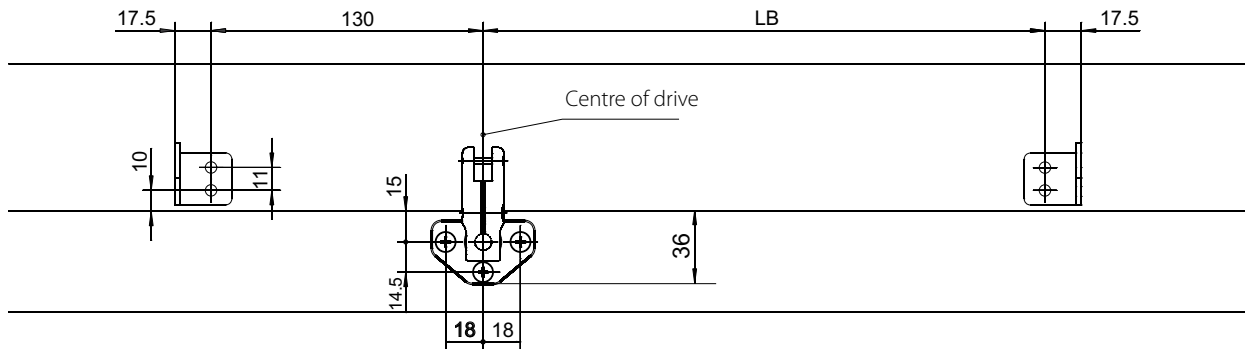

Front view of locking bracket E 860

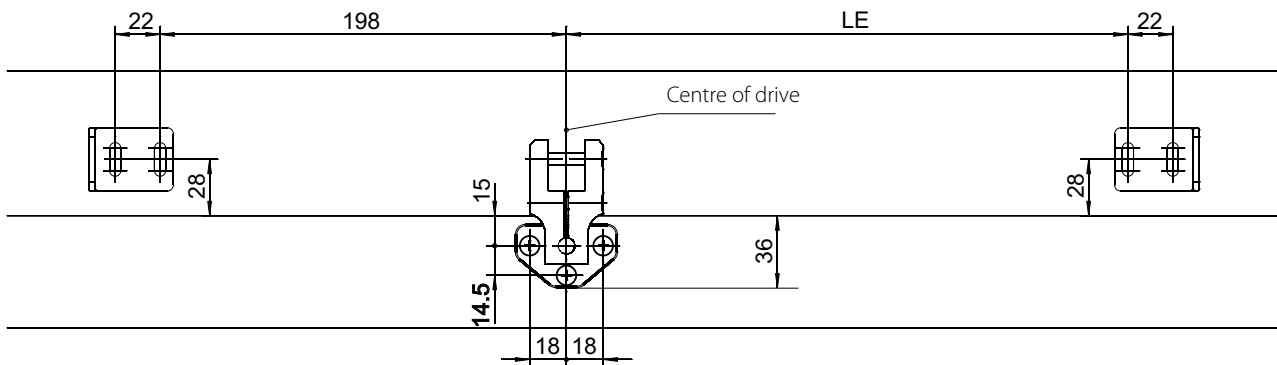

GEZE ELECTRICALLY OPERATED CHAIN DRIVES

GEZE chain drives E 920 – E 990 / 24 V DC

Drives fully integrated into the profile with stroke lengths of 200 to 900 millimetres

The integrated electric chain drive series E 920 – E 990 has no parts that are visible from the outside, because the drive and fittings technology completely disappears inside the window*. This optimises window design and avoids soiling. The drives of the E 920 - E 990 series can be used on inward-opening bottom-hung casements. The continuously adjustable drive stroke for the ventilation and RWA mode allows all the variants to be adapted individually to the ventilation circumstances and the fire protection concept of a building. Even the variant E 990 reaches an opening width of 900 mm in 60 seconds in the RWA case, allowing a correspondingly large amount of smoke to escape. All E 920 - E 990 chain drives can be installed in tested and certified SHEVs in accordance with EN 12101-2. The low current consumption of the drives combined with the emergency power control unit results in an overall solution with an attractive cost/performance ratio.

GEZE E 990

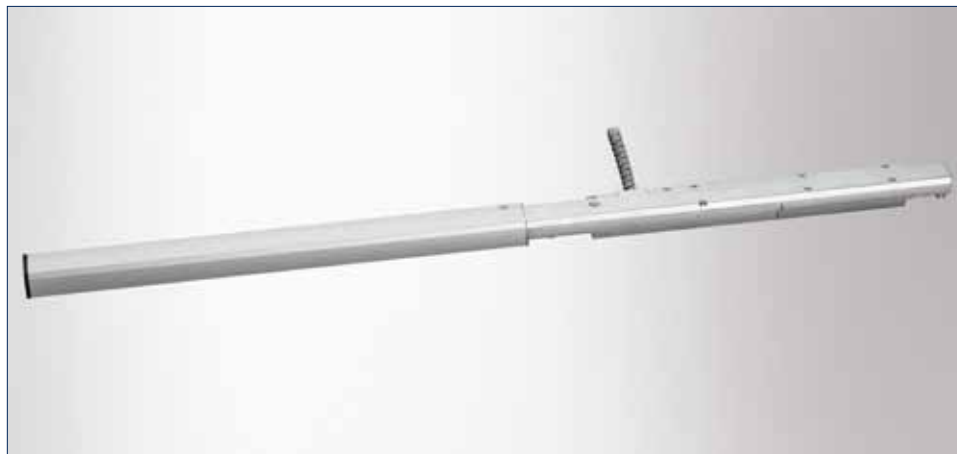

PRODUCT FEATURES

- Fully integrated chain drive
- Stroke lengths of 200 - 900 mm
- Continuously adjustable drive stroke and individual speeds for the ventilation and RWA mode
- Integrated emergency unlocking allows the window to be opened without causing damage, even when the window is locked
- Designed for the Schüco AWS TT profile and further standard profiles
- Simple and time-saving installation thanks to simply clamping the drives
- Individual adjustment of all variants to the specific ventilation circumstances and fire safety concepts in the building
- The high pulling and pushing forces enable even large and heavy leaves to be moved
- DIP switch for manual setting (solo, master, slave)
- Real synchronisation of up to three drives possible without external control unit
- The sealing and thermal characteristics of the window have been maintained

Example of installation

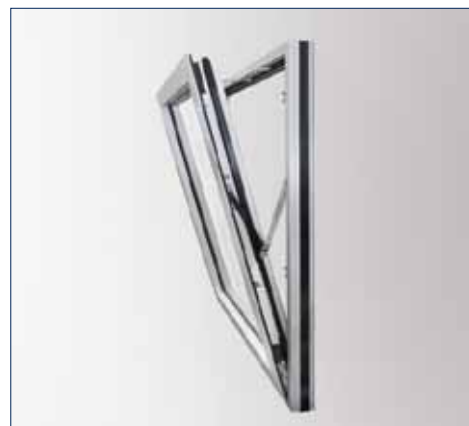

* available for Schüco AWS TipTronic

GEZE ELECTRICALLY OPERATED CHAIN DRIVES

ORDER INFORMATION – GEZE ELECTRIC CHAIN DRIVE E 920 – E 990 / 24 V DC

Description	ID. No.
Chain drive E 920	139571
Chain drive E 940	139572
Chain drive E 950	139573
Chain drive E 970	139574
Chain drive E 990	139575
Chain drive special version	139576
Plug, 5 pcs.	140631
Plug, 50 pcs.	140632
Cover for Schüco plug AWS 5 pcs.	140748
Cover for Schüco plug AWS 50 pcs.	140749
Cover profile flat ribbon cable Schüco AWS 5 m	140750
Cover profile flat ribbon cable Schüco AWS 50 m	140761
Cable crossing 24 V Schüco AWS	140822
Cable crossing Mini 24 V Schüco AWS	142570
Flat ribbon cable 5 m	141614
Flat ribbon cable 50 m	141615
Chain rack EW Schüco AWS	140392
Drive fixture EW Schüco AWS	140393

General application data		Individual operation
Max. casement area		1,5 m ²
Min. casement width (a) symmetrical installation (chain casement centre)	Stroke 200 mm	790 mm
	Stroke 400 mm	790 mm
	Stroke 500 mm	790 mm
	Stroke 700 mm	960 mm
	Stroke 900 mm	1150 mm
Min. casement width (a) asymmetrical installation	Stroke 200 mm	605 mm
	Stroke 400 mm	700 mm
	Stroke 500 mm	745 mm
	Stroke 700 mm	850 mm
	Stroke 900 mm	945 mm
Min. casement height	Stroke 200 mm	700 mm
	Stroke 400 mm	800 mm
	Stroke 500 mm	900 mm
	Stroke 700 mm	1000 mm
	Stroke 900 mm	1200 mm
Max. casement weight bottom hung window		100 kg*
Max. casement weight side hung window		130 kg*
Max. casement width		1200 mm

* The overall weight is limited by the hinges and depends on the profile manufacturer's specifications.

Electrical data E 920 – E 990	
Voltage	24 V +/- 25% SELV
Max. residual ripple U _{ss}	20%
Duty rating	30%
Min. short-term operation	6 min.
Max. power consumption	22 W
Current consumption at max. load	1,0 A: 24 V DC (Ventilation) 1,3 A: 18 V DC (RWA) Emergency power operation of the control unit
Ambient temperature	-5 °C / +70 °C
Enclosure rating / electric protective class	IP 40 / III
Area of application	dry rooms

Mechanical data E 920 – E 990	
Tensile force* / force of pressure	400 N / 250 N
Stroke length	200 - 900 mm
Stroke speed	
Opening for ventilation	5 mm/s
Opening RWA (max.)	17 mm/s
Closing	5 mm/s
End-position cut-off extended	electronically via internal path sensor
End-position cut-off retracted	electronically via path and load
Overload cut-off	electric / electronic via current consumption
Weight	1,1 - 1,5 kg

* Not suitable for use on top-hung or projecting top-hung windows

Electrical data – cable crossing E 920 – E 990	
Max. connection cross-section	4 x 2,5 mm ²
Max. current-carrying capacity	5,5 A
Max. voltage	30 V DC

Opening angle diagram E 920 – E 990

Casement height [mm]

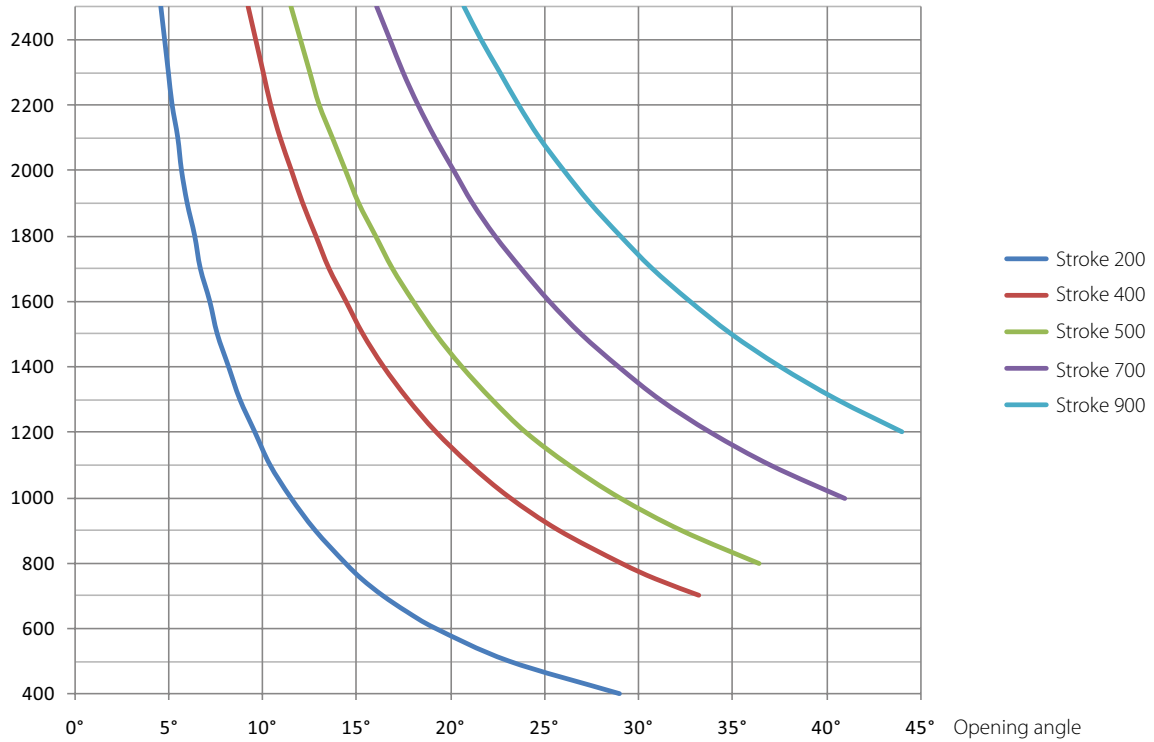

Limitations of use diagram E 920 – E 990

Casement weight [kg]

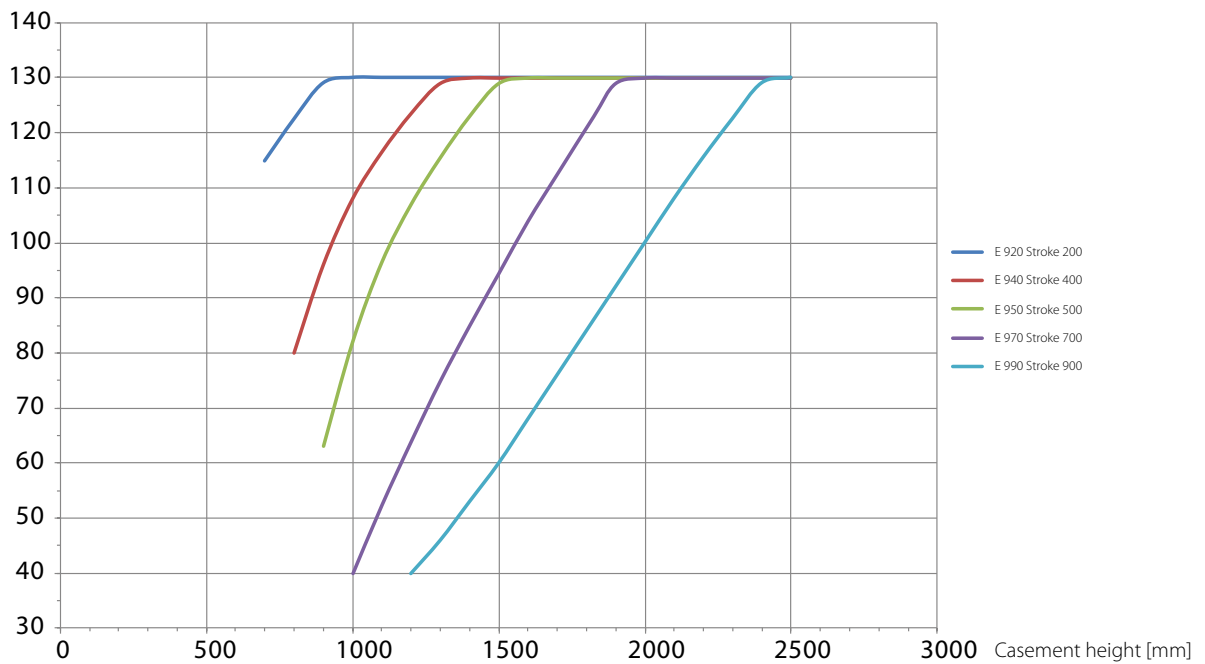

GEZE ELECTRICALLY OPERATED CHAIN DRIVES

Main dimensions

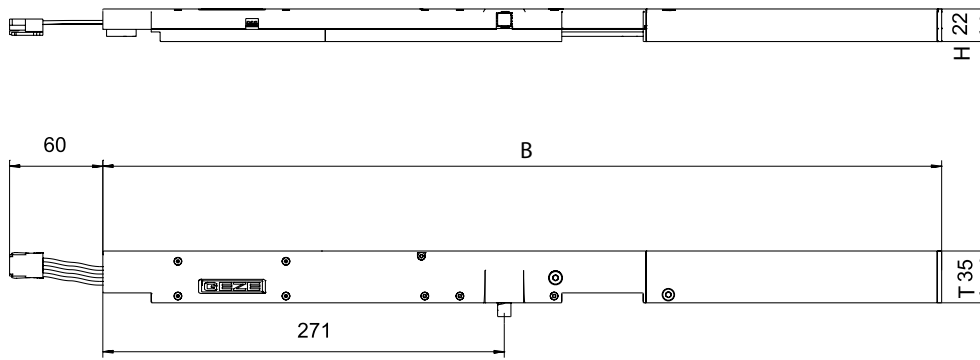

Stroke	Width (B)	Height (H)	Depth (T)
200 mm	450 mm		
400 mm	545 mm		
500 mm	595 mm	35 mm	22 mm
700 mm	695 mm		
900 mm	790 mm		

Window machining

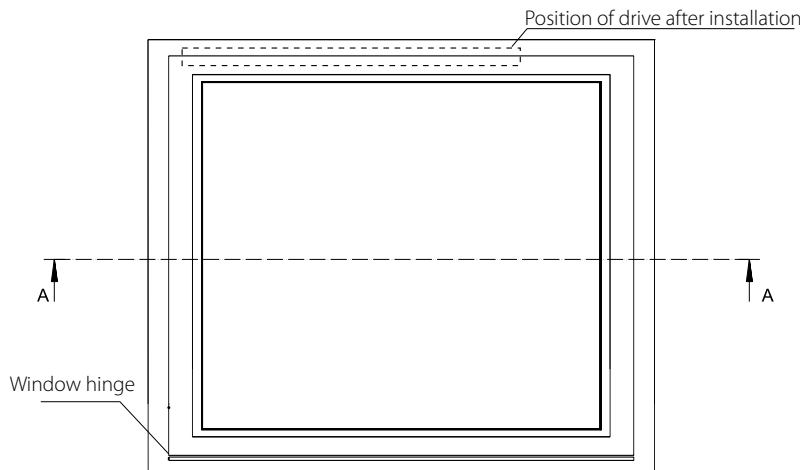

Frame machining

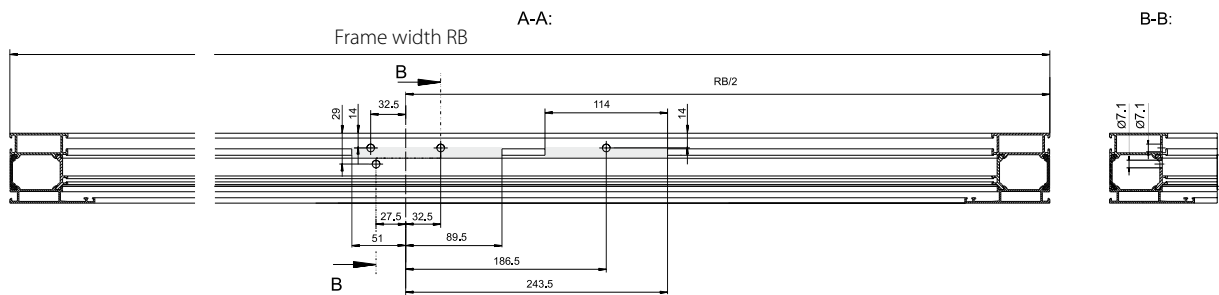

Casement machining

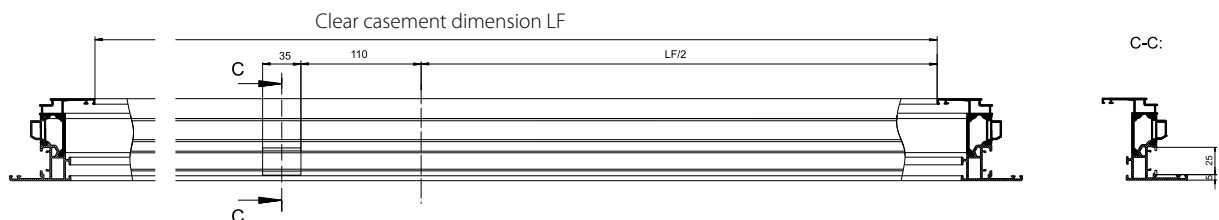

GEZE locking drives E 905 / E 906

Additional safety and protection

Alongside retention force of the drive at the closure point, the trend towards larger and larger windows requires an additional locking unit in order to guarantee the performance classes defined in DIN EN 1435-1, particularly the wind load, resistance to pelting rain and air-tightness. For this reason, an additional lock should be planned for high-quality windows. The new integrated locking drive E 905 / E 906 meets this requirement. It also prevents additional protection against unauthorised entry to the building. Also completely integrated in the window profile, the E 905 / E 906 combined with the drives of the E 920 - E 990 series provides a system solution that can be used to safely open and lock even large window casements. Up to four locking points contribute to the safe locking. Electronic position detection prevents the chain drive opening as long as the locking drive is still locked. This protects the window from incorrect operation and excessive load.

GEZE E 905 / E 906

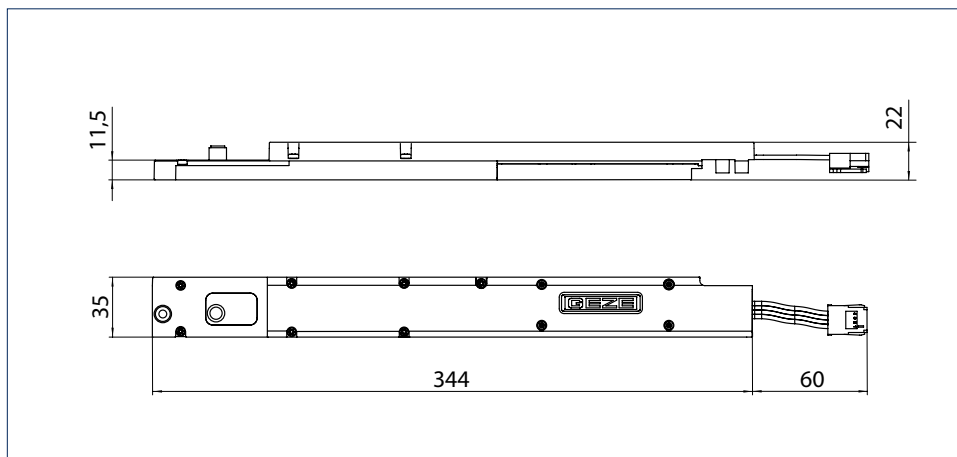

Main dimensions E 905, E 906 mirrored

PRODUCT FEATURES

- Modular system with integrated locking drive
- Designed for the Schüco AWS TT profile system and further standard profiles
- When combined with the chain drives E 920 - E 990, opening is guaranteed in less than 60 seconds, i.e. the system can be used in SHEVs in accordance with EN 12101-2
- One locking drive can operate up to 4 locking points, which means the drive is also suitable for large windows
- An electronic end position cut-off (retracted and extended) prevents excessive running under load – one basis for the long service life of the drive
- The drive can be unlocked from the outside even when closed, by means of accessory tools

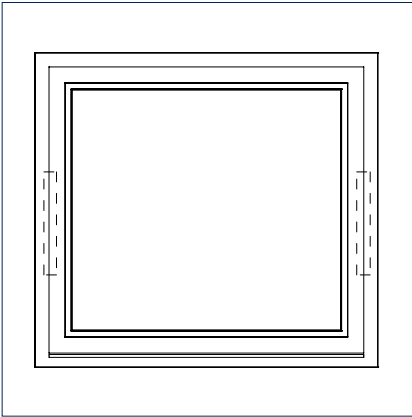
Window processing: Position of the drive after installation

GEZE E 905 / E 906



Detail E 905 / E 906 with safety scissor

Technical data	GEZE E 905 / E 906
Dimensions (W x H x D)	344 x 22 x 35 mm
Locking and unlocking	5 s
Locking points (max.)	4
Supply voltage	24 V \pm 25 %
Current consumption	1.0 A
Microprocessor control	integrated
Emergency unlocking	integrated

ORDERING INFORMATION – GEZE LOCKING DRIVES E 905 / E 906

Description	Id. No.
Locking drive E 905	143904
Locking drive E 906	143905
Drive bracket E 905	143906
Drive bracket E 906	143922

GEZE ELECTRICALLY OPERATED SPINDLE DRIVES

GEZE RWA exhaust systems

RWA electrically operated spindle drives as direct openers



RWA electrical spindle drives are an electrical motor-driven solution for the opening and closing of bottom hung, top hung and side hung windows, skylights and light domes. They can be used for natural smoke and heat extraction as well as smoke dissipation and ventilation.



Electrically operated spindle drives		E 250	E 250 VdS	E 1500 N	E 1500 S	E 3000
Dimensions (mm), HxDxW={}		40 x 47 x {stroke+240}	40 x 47 x {stroke+240}	{ca.302+ stroke}, ø36	{ca.465+ stroke}, ø50	{ca.465+ stroke}, ø50
Stroke length	100 mm	●	●	○	○	○
	150 mm	●	●	○	○	○
	200 mm	●	●	○	○	○
	230 mm	●	●	○	○	○
	300 mm	●	●	●	●	●
	400 mm	○	○	●	●	○
	500 mm	●	●	●	●	●
	600 mm	○	○	○	●	○
	700 mm	●	○	○	○	○
	750 mm	●	○	●	●	●
	1000 mm	●	○	●	●	●
	1200 mm	○	○	○	●	○
Max. pushing/pulling force	750 N/750 N	750 N/750 N	1500 N/1500 N	1500 N/1000 N	3000 N/3000 N	
Start-up speed	5 mm/s	5 mm/s stroke 500: 10 mm/s	4 mm/s *	17 mm/s *	7.8 mm/s *	
End position cut-off on/off	electromechanical	electromechanical	electronic	electronic	electronic	
Overload cut-off	electromechanical	electromechanical	electronic	electronic	electronic	
Voltage	24 V DC	24 V DC	24 V DC	24 V DC	24 V DC	
Power consumption	0.8 A	0.8 A stroke 500: 1,7 A	0.8 A	3.0 A	3.1 A *	
Max. residual ripple	20%	20%	20%	20%	20%	
ON period	100%	30%	30%	30% Solo/ 25% Syncro	30%	
Ambient temperature	-20 °C to +70 °C	-5 °C to +75 °C	-5 °C to +75 °C	-5 °C to +75 °C	-5 °C to +75 °C	
Enclosure rating / protection class	IP65 / III	IP65 / III	IP65 / III	IP54	IP54 / III	
Cables	3x0.75 mm ² , 2 m	3x0.75 mm ² , 2 m	3x1 mm ² , 2.5 m	3x1 mm ² , 3 m	4x0.75 mm ² , 3 m	
Weight	approx. 1.2 to 3.4 kg	approx. 1.2 to 3.4 kg	approx. 1.5 to 2.7 kg	approx. 4.4 to 7.1 kg	approx. 4.1 to 6.5 kg	
Area of application	Dry rooms	Dry rooms	Dry rooms	Dry rooms	Dry rooms	
	E 250 AB: Protected outdoor area					

GEZE ELECTRICALLY OPERATED SPINDLE DRIVES

GEZE spindle drive E 250 / E 250 VdS 24 V DC

Compact drive for a varied range of uses

These electrically operated spindle drives are used for the electrical motor-driven opening and closing of bottom hung, top hung and side hung windows as well as skylights and light domes. They can be used variably for natural smoke and heat extraction as well as smoke dissipation and daily ventilation. The E 250 VdS reaches its full stroke in 60 seconds and is thus suitable for installation in inspected and certified SHEVs in accordance with EN 12101.

Its small dimensions and technically advanced detail solutions such as cables routed on the interior and mechanical load cut-off make it the ideal drive for the direct opening of RWA windows. The E 250 can be used both as a solo drive and in a tandem configuration with the tandem switch E102 for particularly heavy and wide casements.

GEZE E 250



PRODUCT FEATURES

- Suitable for use on small windows thanks to its compact design
- Stroke lengths: 100-1000 mm (longer strokes on request)
- Stroke limiters are optionally available as well as position indicators to monitor end positions
- Internal cable routing
- Mechanical load cut-off

GEZE spindle drive E 250 AB 24 V DC

RWA electrically operated spindle drive with ventilation element

The electrically operated spindle drive E 250 with protection class IP65 is protected against water jets. However, penetration of moisture into the housing cannot be ruled out (air pump effect), and condensation may collect – due to temperature differences – which in turn may lead to the drive becoming damaged.

To solve this problem, GEZE offers a special electrically operated spindle drive with ventilation element: GEZE E 250 AB

Due to its special breathable membrane, this drive is suitable for use in locations with large temperature fluctuations and in protected outdoor areas.

PRODUCT FEATURES

With the electrically operated spindle drive E 250 AB, a component with a breathable membrane ensures that:

- the housing is ventilated
- pressure compensation occurs and this prevents dust and splash-water from penetrating
- the formation of condensation is minimised
- the collected moisture is drained off

Ventilation element

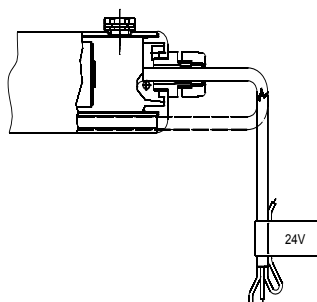

GEZE ELECTRICALLY OPERATED SPINDLE DRIVES

ORDER INFORMATION – GEZE ELECTRICALLY OPERATED SPINDEL DRIVES E 250 / 24 V DC

Description	Version	Id. No.	Id. No.	Id. No.	Id.No.
		E 250 VdS	E 250	E 250 AB	
Stroke 100 mm	EV1	098900		100330	
	white RAL 9016	098904		100334	
	to RAL	098903		100333	
Stroke 150 mm	EV1	098905		100335	
	white RAL 9016	098909		100338	
	to RAL	098908		100339	
Stroke 200 mm	EV1	098910		100340	
	white RAL 9016	098914		100344	
	to RAL	098913		100343	
Stroke 230 mm	EV1	098915		100345	
	white RAL 9016	098919		100349	
	to RAL	098918		100348	
Stroke 300 mm	EV1	098920		100350	
	white RAL 9016	098924		100354	
	to RAL	098923		100353	
Stroke 500 mm	EV1	098925	016458	100355	
	white RAL 9016	098929	016472	100359	
	to RAL	098928	016471	100358	
Stroke 700 mm	EV1		021063	100360	
	white RAL 9016		021066	100364	
	to RAL		021067	100363	
Stroke 750 mm	EV1		021068	100365	
	white RAL 9016		021071	100369	
	to RAL		021072	100368	
Spezial version	EV1	111173	111173	111262	
	white RAL 9016	111173	111173	111262	
	to RAL	111174	111174	111263	
Standard bracket for direct opening with jack rings and casement bracket	EV1 (silver)				019032
	white RAL 9016				020879
	to RAL				020878
Inward-opening bracket with jack rings and casement bracket	EV1 (silver)				027218
	white RAL 9016				027223
	to RAL				027222
Swivel bracket for spindle drives	EV1 (silver)				116112
	white RAL 9016				116113
	to RAL				116114
Basic unit for stroke limitation and position indication					083941
Stroke limitation circuit board 24 V DC					084125
Additional circuit board for position indication for 1-4 ventilator assemblies					084171

GEZE ELECTRICALLY OPERATED SPINDLE DRIVES

Accessories for GEZE electrically operated drives E 250 / E 250 VdS / E 250 AB



Standard bracket

GEZE standard bracket

for direct opening of the E 250

Scope of supply with jack rings and casement bracket



Inward-opening bracket

GEZE inward-opening bracket

for direct opening of the E 250 on windows that open inwards

Scope of supply with jack rings and casement bracket



Swivel bracket

GEZE swivel bracket

for direct opening of the E 250

Scope of supply with jack rings, casement bracket and countersunk screws

With the swivel bracket the spindle drive E 250 can be fitted in a tandem version directly to the side closing edge. This results in a greater opening width compared with a fitting with comparable stroke length at the main closing edge of the skylight.



Basic unit for stroke limitation

GEZE basic unit for stroke limitation (and position indication)

Scope of supply with reed switch, cable tie and cable run

(Drawing no. 45130-9-0990)



Stroke limitation circuit board

GEZE stroke limitation circuit board

For limiting the stroke, a basic unit should be fitted in addition to the stroke limitation circuit board (see drawing no. 45130-9-0990)



Additional circuit board for position indication

GEZE additional circuit board for position indication for 1-4 ventilator assemblies

For position indication, one or two basic units (depending on the application) should be fitted in addition to the position indication circuit board (see drawing no. 45130-9-0990)

GEZE ELECTRICALLY OPERATED SPINDLE DRIVES

RWA electrically operated spindle drive E 250 as direct opener

The electrically operated spindle drive E 250 is used for the direct opening of bottom hung and top hung windows as well as skylights and light domes with a slidable standard bracket made of light metal. The E 250 AB with ventilation element is suitable for use in locations with large temperature fluctuations and in protected outdoor areas.

Two drives can be installed in tandem configuration for very large and heavy casements. Connection is through a special tandem switch E102/24 V.

Important: This tandem version is recommended with a main closing edge of 1.2 m or longer depending on the profile system used.



Synchronised cut-off E 102

GEZE tandem switch E102

The tandem switch is used for the simultaneous switching of two electrically operated spindle drives 24 V DC mounted on one window element. Adjustable run-on time ensures that running time differences between the two drives in the end position can be compensated to give equal contact pressure on the casement.

- Supply voltage 24 V DC, min. 16 V DC, max. 40 V DC, residual ripple max. 25%
- Connectable motors two 24 V DC drives with integrated load cut-off
- Motor current per motor max. 2.2 A
- Time delay can be set between 0 to 10 sec., default setting 0 sec.
- Opening time limit can be set between 5 and 60 sec., default setting approx. 5 sec.
- Connection cross-section max. 2.5 mm²
- Enclosure rating IP 54
- Dimensions (H x B x D) 113 x 113 x 58 mm

Description	Id. No.
Synchronised cut-off E 102	101323

Dimensional drawing RWA – electrically operated spindle drive E 250

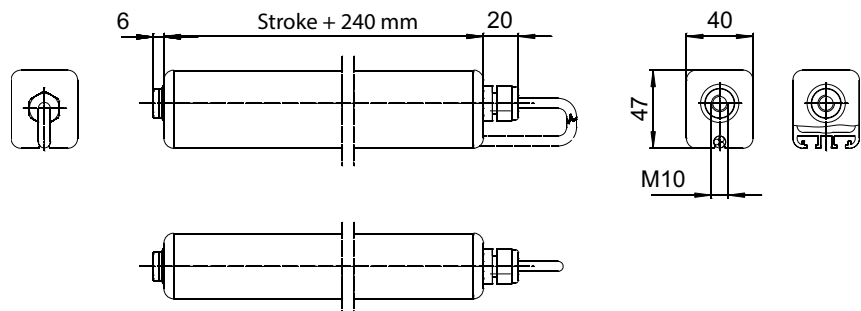

Special version with connecting plug

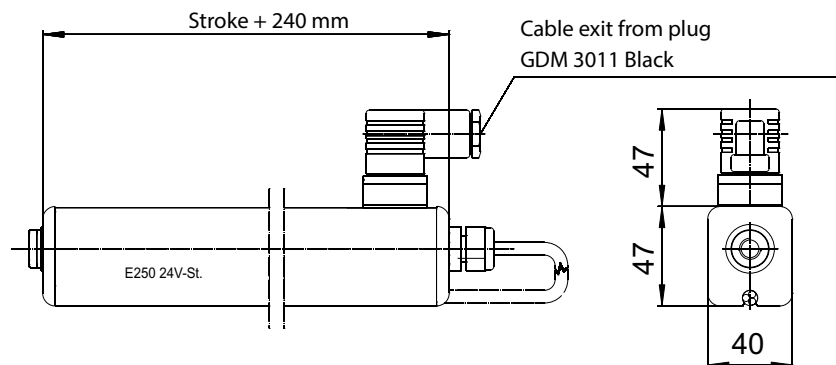

GEZE ELECTRICALLY OPERATED SPINDLE DRIVES

Application areas

Bottom hung, top hung and side hung windows

INWARD-OPENING

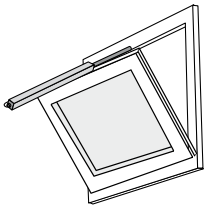

Permissible casement weight **without** taking additional loads into consideration:

- Solo: max. 100 kg
- Tandem: max. 200 kg

Max. permissible motor stroke: 500 mm

Minimum casement heights

Stroke	Casement height
100 mm	
150 mm	
200 mm	200 mm
230 mm	230 mm
300 mm	300 mm
500 mm	600 mm

OUTWARD-OPENING

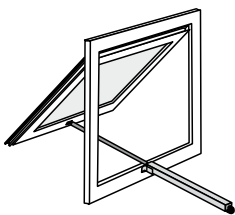

Permissible casement weight **without** taking additional loads into consideration:

- Solo: max. 100 kg
- Tandem: max. 200 kg

Max. permissible motor stroke: 500 mm

Minimum casement heights

Stroke	Casement height
100 – 300 mm	400 mm
500 mm	600 mm

GEZE electrically operated spindle drive E 250 on bottom hung window

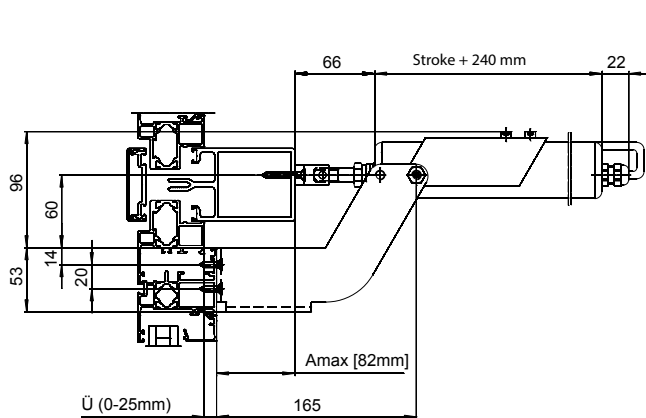

GEZE electrically operated spindle drive E 250 on top hung window

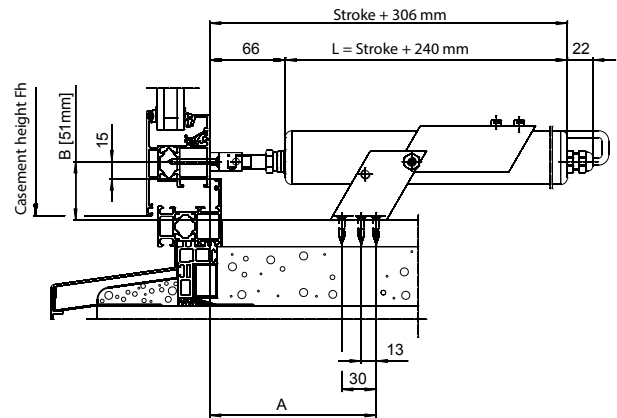

Identification numbers of the installation drawings and wiring diagrams

	Electrically operated spindle drive E 250	Drawing No.
Installation drawings	Bottom, top and side hung windows, outward opening	45130-0-002
	Inward-opening bottom hung, top hung and side hung windows	45130-0-003
Wiring diagrams		45130-9-0950

GEZE ELECTRICALLY OPERATED SPINDLE DRIVES

Application areas

Skylights and light domes

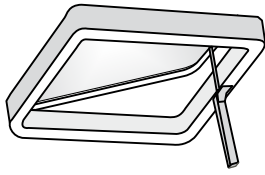

Permissible casement weight **without** taking additional loads into consideration:

- Solo: max. 100 kg
- Tandem: max. 200 kg

Max. permissible motor stroke: 1000 mm

Minimum casement heights

Stroke	Casement height
100 mm	220 mm
150 mm	270 mm
200 mm	320 mm
230 mm	350 mm
300 mm	440 mm
500 mm	670 mm
700 mm	910 mm
750 mm	980 mm
1000 mm	1270 mm

GEZE electrically operated spindle drive E 250 on light dome

GEZE electrically operated spindle drive E 250 on skylight

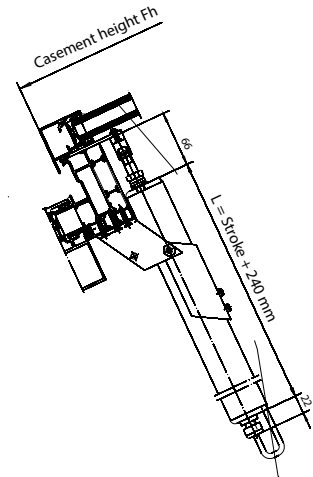
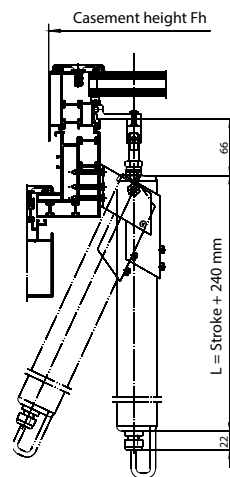
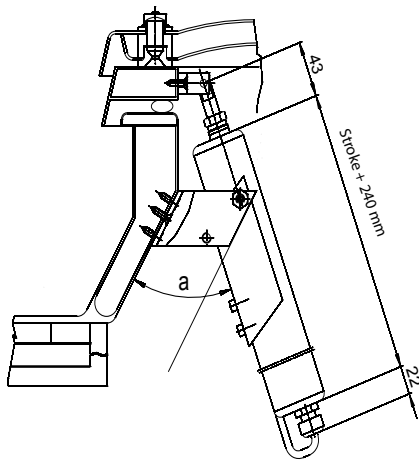

Identification numbers of the installation drawings and wiring diagrams

	Electrically operated spindle drive E 250	Drawing No.
Installation drawings	Skylight with frame bracket	45130-9-1000
	Skylight general	45130-0-001
Wiring diagrams		45130-9-0950

GEZE ELECTRICALLY OPERATED SPINDLE DRIVES

Swivel bracket for E 250

With the swivel bracket the direct openers can be fitted in a tandem version directly to the side closing edge and thus achieve greater opening widths compared with a fitting with comparable stroke length at the main closing edge of the skylight.

Permissible total casement weight F_{gmax} with swivel bracket:

$$F_{gmax} = \frac{200 * x}{H}$$

Opening angle

Diagram for determining opening angle J depending on stroke and fitting dimension X.

(With casement heights H greater 1000 mm, the following applies: dimension X should be at least 1/2 H.)

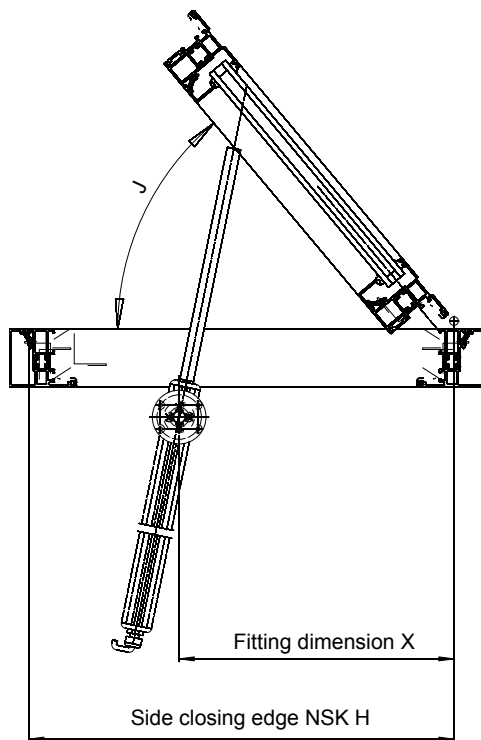

Drives on the side closing edges

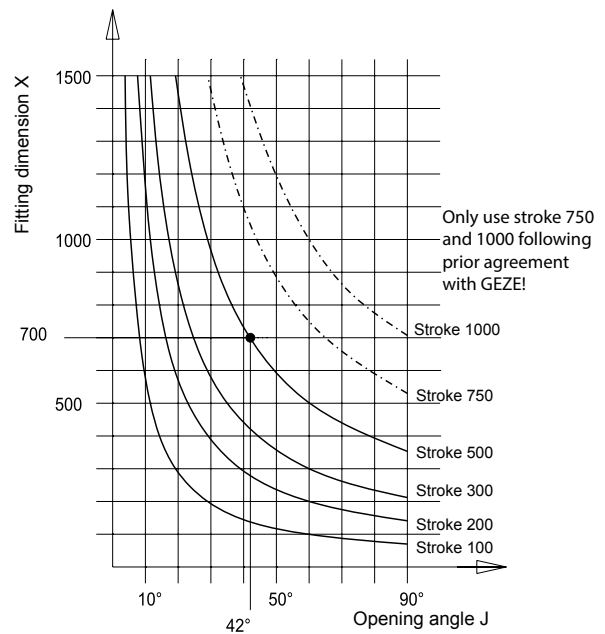
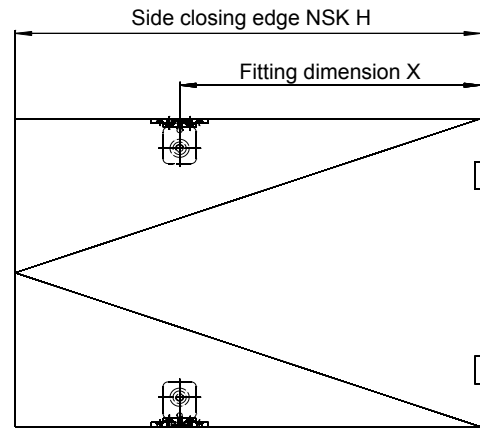

Example:

Stroke = 500 mm
 Fitting dimension x = 700 mm
 -> Opening angle = approx. 42°

Notes:

Snow and wind loads must be taken into consideration
 Stroke 750 and 1000 mm only on request

Note for installation examples:

The minimum casement heights specified are only reference values, since they depend on the installation situation, fitting dimension and stroke.

The drive must not collide with a structure or any other obstacle in the swivelling range.

GEZE ELECTRICALLY OPERATED SPINDLE DRIVES

GEZE spindle drive E 1500 N and E 1500 S 24 V DC

RWA electrically operated spindle drive as solo or synchronous solution for heavy casements

The electrically operated spindle drive is suitable for the electrical motor-driven opening and closing of bottom hung, top hung and side hung windows as well as skylights. The outstanding features of this high-quality electrically operated spindle drive are its sturdy corrosion-resistant design, integrated end-position damping, aluminium housing and silicone connecting cable. The drives can be used variably for natural smoke and heat extraction as well as smoke dissipation and daily ventilation.

The E 1500 S variant reaches its full stroke of 1000 mm in 60 seconds and is thus suitable for installation in inspected and certified SHEVs in accordance with EN 12101-2.

GEZE E 1500 S



PRODUCT FEATURES

- Electrically operated spindle drive for daily ventilation as well as for safe and fast smoke and heat extraction and smoke dissipation
- Can be used as a solo or synchronous drive for especially heavy and wide casements in connection with the synchronisation control E 1500 N or E 1500 S
- High protection rating of IP65 (IP54 for E 1500 S)
- Suitable for use in tested and certified GEZE SHEVs to EN 12101-2

ORDER INFORMATION – GEZE ELECTRICALLY OPERATED SPINDLE DRIVES E 1500 N AND 1500 S 24 V DC

Description	Version	Id. No.		Id. No.	
		E 1500 N		E 1500 S*	
		Solo	Syncro	Solo	Syncro
Stroke 300 mm	EV1 (silver)	141894	141919	138428	138458
	white RAL 9016	141895	141920	138429	138459
	to RAL	141896	141931	138430	138460
Stroke 400 mm	EV1 (silver)	141897	141932	138441	138461
	white RAL 9016	141898	141933	138442	138462
	to RAL	141899	141934	138443	138463
Stroke 500 mm	EV1 (silver)	141900	141935	138444	138464
	white RAL 9016	141911	141936	138445	138465
	to RAL	141912	141937	138446	138466
Stroke 600 mm	EV1 (silver)			138447	138467
	white RAL 9016			138448	138468
	to RAL			138449	138469
Stroke 750 mm	EV1 (silver)	141913	141938	138450	138470
	white RAL 9016	141914	141939	138451	138471
	to RAL	141915	141940	138452	138472
Stroke 1000 mm	EV1 (silver)	141916	141941	137184	137185
	white RAL 9016	141917	141942	138453	138474
	to RAL	141918	141943	138454	138475

GEZE ELECTRICALLY OPERATED SPINDLE DRIVES

Description	Version	Id. No.		
		E 1500 N	E 1500 S*	
Stroke 1200 mm	EV1 (silver)		138455	138476
	white RAL 9016		138456	138477
	to RAL		138457	138478
Special version		141945		
	EV1 (silver)	141944	141946	
Clamp ring E 1500	EV1 (silver)			121215
	white RAL 9016			121216
	to RAL			121217
Casement bracket E 1500	EV1 (silver)			121218
	white RAL 9016			121219
	to RAL			121220
Casement bracket E 1500 FS (with limited horizontal space for casement bracket E 1500)	EV1 (silver)			123085
	white RAL 9016			123086
	to RAL			123087
Skylight bracket E 1500 H40 (mainly for flat-closing windows)	EV1 (silver)			121221
	white RAL 9016			121222
	to RAL			121223
Skylight bracket E 1500 H86 (mainly for windows with projection)	EV1 (silver)			121224
	white RAL 9016			121225
	to RAL			121226
Bracket E 1500 for bottom, top and side hung windows	EV1 (silver)			123088
	white RAL 9016			123089
	to RAL			123090

* Accessories for E 1500 S see E 3000

Accessories for GEZE electrically operated drives E 1500 N



Casement bracket E 1500



Casement bracket E 1500 FS

GEZE casement bracket E 1500
for fixing the spindle to the casement

GEZE casement bracket E 1500 FS
angled casement bracket for use where horizontal space
is limited



Clamp ring E 1500



Bracket E 1500

GEZE clamp ring E 1500
scope of supply with DIN 912 screw and two shouldered
screws

GEZE bracket E 1500
for bottom, top and side hung windows



Skylight bracket E 1500 H40



Skylight bracket E 1500 H86

GEZE skylight bracket E 1500 H40
mainly for flat-closing windows

GEZE skylight bracket E 1500 H86
mainly for windows with projection

GEZE ELECTRICALLY OPERATED SPINDLE DRIVES

RWA electrically operated spindle drive E 1500 N as direct opener

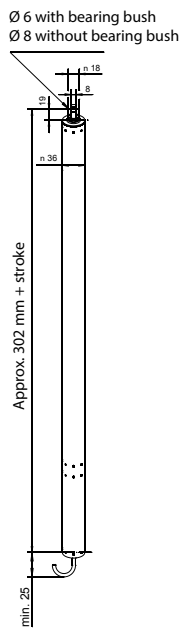

For the electrical motor-driven opening and closing of bottom hung, top hung and side hung windows as well as skylights. Can be used variably for natural smoke and heat extraction as well as smoke dissipation and ventilation, available both for solo operation and as a synchronous solution for particularly heavy and wide casements. The synchronous control unit E 1500 is required for synchronous operation.

Important: The Syncro version is recommended from 1.2 m main closing edge, depending on the profile system used.

Identification numbers of the installation drawings and wiring diagrams

	Electrically operated spindle drive E 1500 N	Drawing No.
Installation drawings	Solo/Synchronic bottom hung/top hung/skylight at main closing edge	45144-EP-001
	Synchronic skylight at secondary closing edge	45144-EP-002
Wiring diagrams	Synchronic control unit	122481

Application areas

Bottom hung and top hung windows

INWARD-OPENING

Max. permissible motor stroke: 500 mm

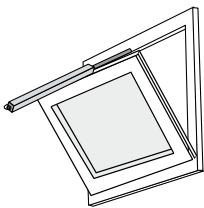

Casement dimensions

Type of window	Minimum casement height		Maximum casement width	
	Stroke 300 mm	Stroke 500 mm	Solo	Tandem
Bottom hung window	650 mm	1200 mm	max. 1200 mm	max. 2400 mm
Top hung windows	400 mm	400 mm	max. 1200 mm	max. 2400 mm

OUTWARD-OPENING

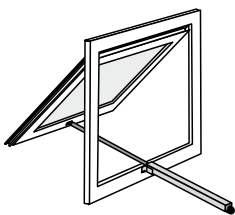

Casement weights

Top hung windows	Stroke 300 mm		Stroke 500 mm	
	Casement height	Solo	Tandem	Solo
400-650 mm	max. 180 kg	max. 360 kg	max. 150 kg	max. 300 kg
650-1200 mm	max. 200 kg	max. 400 kg	max. 170 kg	max. 340 kg
1200-1700 mm	max. 250 kg	max. 500 kg	max. 200 kg	max. 400 kg

Bottom hung window	Stroke 300 mm		Stroke 500 mm	
	Casement height	Solo	Tandem	Solo
650-1200 mm	max. 200 kg	max. 400 kg	max. 170 kg	max. 340 kg
1200-1700 mm	max. 250 kg	max. 500 kg	max. 200 kg	max. 400 kg

Skylight

Max. permissible motor stroke: 1000 mm

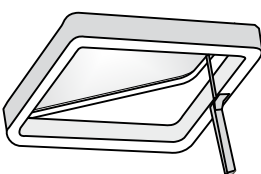

Type of window	Solo	Tandem
Casement weights for all strokes	max. 180 kg	max. 360 kg
Maximum casement width	max. 1200 mm	max. 2400 mm

Calculation of the swivelling range:

The space required under the skylight for swivel movement of the drive depends on the casement height (larger casement height - smaller swivel).

GEZE ELECTRICALLY OPERATED SPINDLE DRIVES

GEZE E 1500 N with skylight bracket H40

Installation of spindle drive E 1500 N on skylight with casement bracket E 1500 With skylight bracket E 1500 H40

Guideline values based on installation example

Attention: Diagram and tables contain guideline values only and refer to the applications as shown below. If the installation conditions differ, the values must be determined on site.

Clearance under the skylight for swivel movement of the drive during opening movement, see "space requirement" diagram

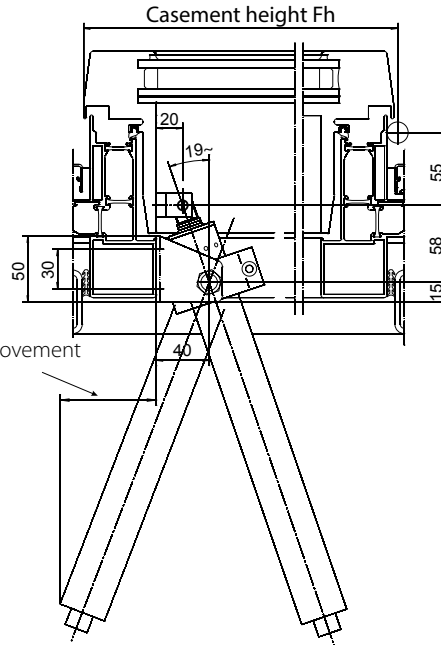

Space required for swivelling

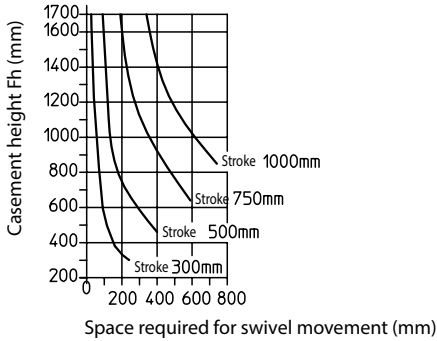

Minimum casement height for E 1500 N on skylight (guideline values*)

E 1500 N stroke	Casement height Fh	Opening angle	Space required for drive swivel under skylight
1000 mm	850 mm	approx. 85°	min. 740 mm
750 mm	640 mm	approx. 85°	min. 590 mm
500 mm	460 mm	approx. 85°	min. 400 mm
300 mm	300 mm	approx. 85°	min. 240 mm

* Due to the large range of window profiles and installation options with baseplates on site, we recommend examining the installation on site, especially where limited space is available.

Opening angle

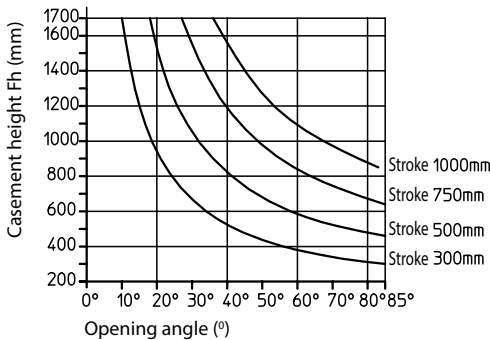

Example:

Space requirement for drive swivel under skylight at opening angle approx. 60°

E 1500 N stroke	Casement height Fh	Opening angle	Space required for drive swivel under skylight
1000 mm	1100 mm	approx. 60°	min. 540 mm
750 mm	850 mm	approx. 60°	min. 410 mm
500 mm	600 mm	approx. 60°	min. 270 mm
300 mm	380 mm	approx. 60°	min. 160 mm

Space requirement under skylight for swivel movement of the drive depends on casement height (larger casement height = smaller swivel).

GEZE ELECTRICALLY OPERATED SPINDLE DRIVES

GEZE E 1500 N with skylight bracket H86

Installation of spindle drive E 1500 N on skylight with casement bracket E 1500 and skylight bracket E 1500 H86

Guideline values based on installation example

Attention: Diagram and tables contain guideline values only and refer to the applications as shown below. If the installation conditions differ, the values must be determined on site.

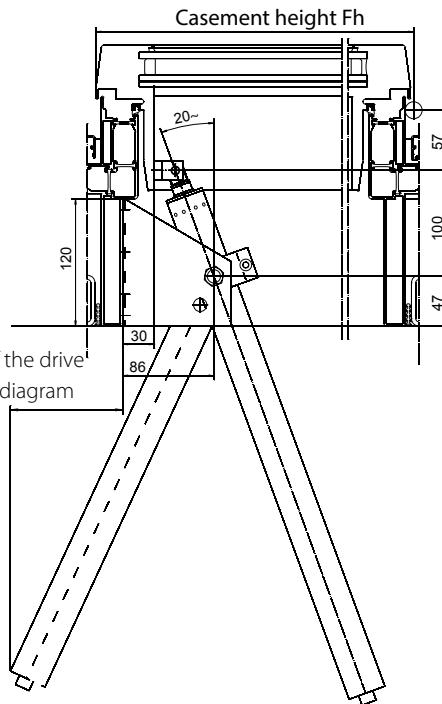

Clearance under the skylight for swivel movement of the drive during opening movement, see "space requirement" diagram

Space required for swivelling

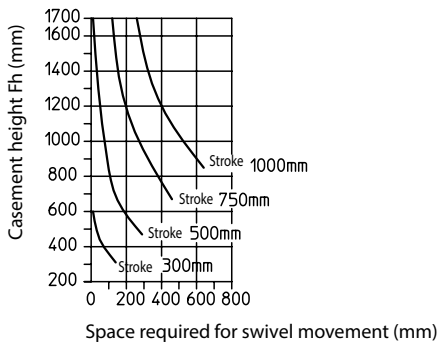

Minimum casement height for E 1500 N on skylight (guideline values*)

E 1500 N stroke	Casement height Fh	Opening angle	Space required for drive swivel under skylight
1000 mm	850 mm	approx. 85°	min. 640 mm
750 mm	670 mm	approx. 85°	min. 460 mm
500 mm	470 mm	approx. 85°	min. 290 mm
300 mm	310 mm	approx. 85°	min. 140 mm

* Due to the large range of window profiles and installation options with baseplates on site, we recommend examining the installation on site, especially where limited space is available.

Opening angle

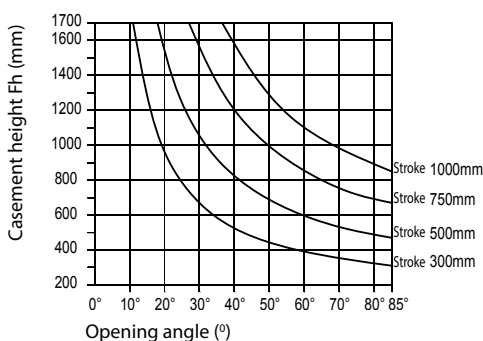

Example:

Space requirement for drive swivel under skylight at opening angle approx. 60°

E 1500 N stroke	Casement height Fh	Opening angle	Space required for drive swivel under skylight
1000 mm	1100 mm	approx. 60°	min. 460 mm
750 mm	850 mm	approx. 60°	min. 320 mm
500 mm	600 mm	approx. 60°	min. 180 mm
300 mm	400 mm	approx. 60°	min. 70 mm

Space requirement under skylight for swivel movement of the drive depends on casement height (larger casement height = smaller swivel).

GEZE ELECTRICALLY OPERATED SPINDLE DRIVES

GEZE spindle drive E 3000 24 V DC

RWA electrically operated spindle drive as solo or synchronic solution for heavy skylights

The electrically operated spindle drive E 3000 is used for electric motor-operated opening and closing of rooflights. It is suitable for both natural smoke and heat extraction and for smoke dissipation and for daily ventilation. The E 3000 can be used on particularly large and heavy rooflights as a real synchronous solution with synchro control.

The robust, corrosion-resistant version, the built-in end position damping, the aluminium housing and the silicone connection cable are the outstanding features of this high-quality electrically operated spindle drive.

GEZE E 3000



PRODUCT FEATURES

- Stroke length 1000 mm (longer stroke lengths available on request)
- Use as solo drive with load cut-off E 3000 and the E 3000 synchronic control unit is required for synchronous operation
- Silicone connection cable
- Suitable for use in tested and certified GEZE SHEVs to EN 12101-2

ORDER INFORMATION – GEZE ELECTRICALLY OPERATED SPINDLE DRIVES E 3000 / 24V DC

Description	Version	Id. No.		
		E 3000	Load cut-off	Synchronic control unit
Stroke 300 mm	EV1 (silver)	121227		
	white RAL 9016	121228	121272	121273
	to RAL	121229		
Stroke 500 mm	EV1 (silver)	121230		
	white RAL 9016	121241	121889	121983
	to RAL	121242		
Stroke 750 mm	EV1 (silver)	121243		
	white RAL 9016	121244	121890	121984
	to RAL	121245		
Stroke 1000 mm	EV1 (silver)	121246		
	white RAL 9016	121247	121981	121985
	to RAL	121248		
Special version	EV1 (silver)	121249		
	to RAL	121250	121982	121986
Clamp ring E 3000	EV1 (silver)			121274
	white RAL 9016			121275
	to RAL			121276
Casement bracket E 3000	EV1 (silver)			121277
	white RAL 9016			121278
	to RAL			121279
Skylight console E 3000	EV1 (silver)			121280
	white RAL 9016			121291
	to RAL			121292

Accessories for GEZE electrically operated spindle drives E 3000



Load cut-off E 3000

GEZE load cut-off E 3000

An additional E 3000 load cut-off is required for solo operation of the E 3000.



Synchronic control unit E 3000

GEZE synchronic control unit E 3000

An additional synchronic control unit E 3000 is required for synchronous operation of the E 3000 Synchron. An additional load cut-off is not necessary as this is included in the external synchronic control unit.



Clamp ring E 3000

GEZE clamping ring E 3000

Scope of supply with two collar screws



Casement bracket E 3000

GEZE casement bracket E 3000

for fixing the spindle to the casement



Skylight console E 3000

GEZE skylight console E 3000

for fixing the E 3000 drive to the frame of the skylight

GEZE ELECTRICALLY OPERATED SPINDLE DRIVES

RWA – electrically operated spindle drive E 3000 as direct opener

Ø 6 with bearing bush
Ø 8 without bearing bush

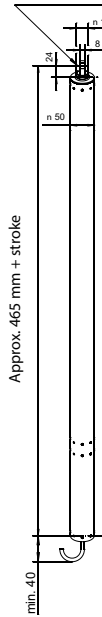

For electric motor-operated opening and closing of rooflights. The E 3000 can be variably used for natural smoke and heat extraction and smoke dissipation as well as for ventilation. Can be used both as a solo drive and a synchronous solution for particularly wide and heavy casements.

Important: The Syncro version is recommended from 1.2 m main closing edge, depending on the profile system used.

Identification numbers of the installation drawings and wiring diagrams

	Electrically operated spindle drive E 3000	Drawing No.
Installation drawings	Solo/Synchron skylight at main closing edge	45145-EP-001
Wiring diagrams	Synchronic control unit	122485
	Load cut-off	122486

Application areas

Skylight

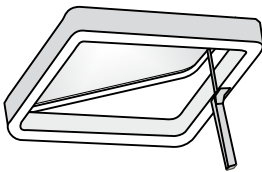

Motor stroke: 400 mm

Type of window	Solo	Tandem
Casement weights for all strokes	max. 180 kg	max. 360 kg
Maximum casement width	max. 1200 mm	max. 2400 mm

Calculation of the swivelling range:

The space required under the skylight for swivel movement of the drive depends on the casement height (larger casement height - smaller swivel).

GEZE E 3000 with Skylight console H86

Installation of spindle drive E 3000 Solo or Synchron on the skylight (main closing edge) with casement bracket E 3000 and skylight bracket E 3000

Guideline values based on installation example

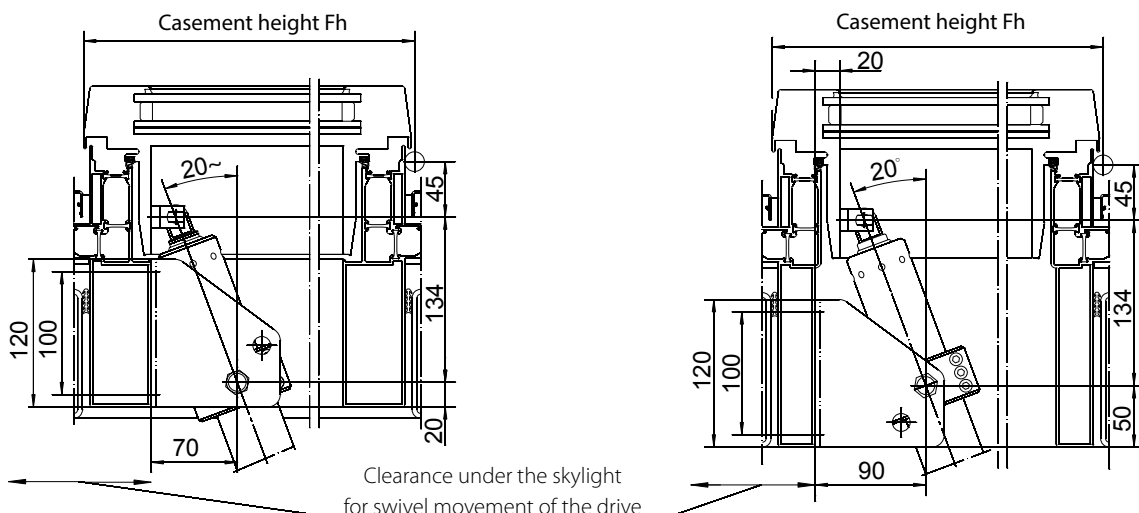

Clearance under the skylight for swivel movement of the drive during opening movement, see "space requirement" diagram

GEZE E 3000 with Skylight console H86

GEZE RWA

Smoke and heat extraction systems (RWA)

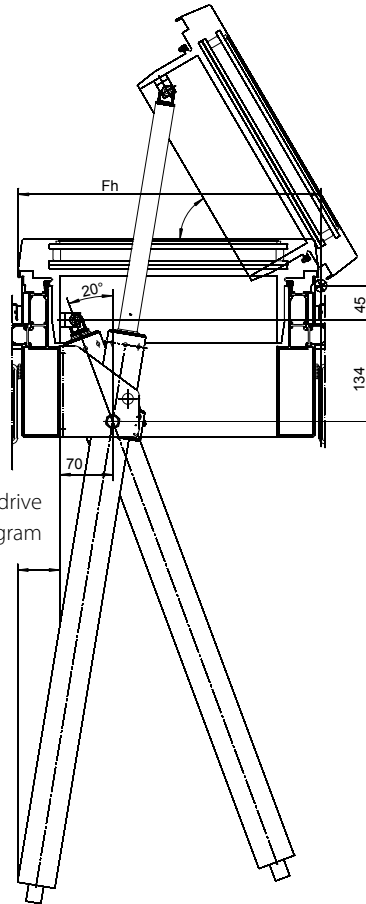

Clearance under the skylight for swivel movement of the drive during opening movement, see "space requirement" diagram

Space required for swivelling

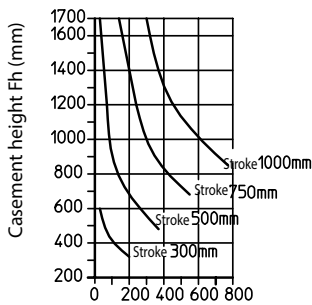

Space required for swivel movement (mm)

Opening angle

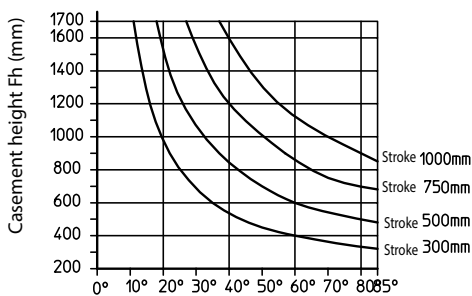

Opening angle (°)

Minimum casement height for E 3000 on skylight (guideline values)

E 1500 stroke	Casement height Fh	Opening angle	Space required for drive swivel under skylight
1000 mm	850 mm	approx. 85°	min. 770 mm
750 mm	680 mm	approx. 85°	min. 550 mm
500 mm	480 mm	approx. 85°	min. 370 mm
300 mm	320 mm	approx. 85°	min. 200 mm

Example:

Space requirement for drive swivel under skylight at opening angle approx. 60°

E 1500 stroke	Casement height Fh	Opening angle	Space required for drive swivel under skylight
1000 mm	1100 mm	approx. 60°	min. 520 mm
750 mm	850 mm	approx. 60°	min. 380 mm
500 mm	600 mm	approx. 60°	min. 240 mm
300 mm	400 mm	approx. 60°	min. 110 mm

Space requirement under skylight for swivel movement of the drive depends on casement height (larger casement height = smaller swivel).

GEZE RWA exhaust systems

Opening and locking systems RWA 100E, RWA 105E and RWA 110E



GEZE's RWA opening and locking systems include the RWA 100E, RWA 105E and RWA 110E. They are available as corresponding tandem versions in combination with the synchronised cut-off E102. They are suitable for both natural smoke and heat extraction, smoke dissipation and for ventilation. The systems consist of a mechanical bracket set combined with the high-quality RWA electrically operated spindle drive E 250 VdS. Thanks to the mechanical locking it is not necessary to use additional electrical locking drives.



RWA systems	RWA 100E	RWA 105E	RWA 110E
Main area of use	Inward-opening bottom hung, top hung and side hung windows	Post & rail constructions and inward-opening side hung windows	Outward-opening top hung windows
Dimensions (width x height x depth)	Stroke + 240 x 40 x 47	Stroke + 240 x 40 x 47	Stroke + 240 x 40 x 47
Stroke length	100 mm ● 150 mm ● 200 mm ● 230 mm ○ 300 mm ●	● ● ○ ● ○	○ ● ● ○ ●
Max. pushing/pulling force	750 N/750 N VdS nominal force 500 N	750 N/750 N VdS nominal force 500 N	750 N/750 N VdS nominal force 500 N
Pushing speed	5 mm/s	5 mm/s	5 mm/s
End position cut-off on/off	electromechanical	electromechanical	electromechanical
Overload cut-off	electromechanical	electromechanical	electromechanical
Voltage	24 V DC (+30% to -20%)	24 V DC (+30% to -20%)	24 V DC (+30% to -20%)
Power consumption	0.8 A	0.8 A	0.8 A
Power consumption	20 W	20 W	20 W
Max. residual ripple	20%	20%	20%
Ambient temperature	-5 °C to +75 °C	-5 °C to +75 °C	-5 °C to +75 °C
Enclosure rating / protection class	IP65 / III	IP65 / III	IP65 / III
VdS approval	●	●	●
Cables	3 x 0.75 mm ² , 2 m	3 x 0.75 mm ² , 2 m	3 x 0.75 mm ² , 2 m
Weight	approx. 2.6 to 3.1 kg	approx. 3.3 to 3.6 kg	approx. 3.3 to 3.6 kg
Area of application	Dry rooms	Dry rooms	Dry rooms

● = yes ○ = no

GEZE OPENING AND LOCKING SYSTEMS

Overview of the systems

RWA systems	RWA 100E	RWA 105E	RWA 110E
Main area of use	Bottom hung, top hung and side hung windows inward-opening	Post & rail constructions side hung windows, inward-opening	Bottom hung and top hung windows outward-opening
vertical, inward-opening windows	●	●	○
vertical, outward-opening windows	○	○	●
Permissible HSK dimensions for Solo:			
for wood and aluminium	360 – 1200 mm	depending on stroke	430 – 1200 mm
for plastic	360 – 800 mm	depending on stroke	430 – 800 mm
Permissible HSK dimensions for Tandem:			
for wood and aluminium	800 – 2400 mm	depending on stroke	850 – 2400 mm
for plastic	900 – 1600 mm	depending on stroke	850 – 1600 mm
Casement heights for Solo/Tandem	470 – 1700 mm	depending on stroke	600 – 1600 mm
Max. panel weight	30 kg/m ²	30 kg/m ²	30 kg/m ² (bottom hung 25 kg/m ²)
Space requirement	Locking side: min. 32 mm Motor side: min. 48 mm	Perimeter frame: 18 mm Casement: 38 mm Post and rail height max. 125 mm	Casement frame: min. 33 mm Perimeter frame: min. 45 mm
Tandem operation	● with synchronised cut-off E102	● with synchronised cut-off E102	● with synchronised cut-off E102
Locking and additional bracket	● from 1.2 m ² window area, 2 locking devices required (standard and additional lock)	● with 2 locking brackets	● from 1.2 m ² window area, 2 locking devices required (standard and additional lock)
i dimension max.	70 mm	70 mm	70 mm

● = yes ○ = no

RWA 100E on bottom hung window

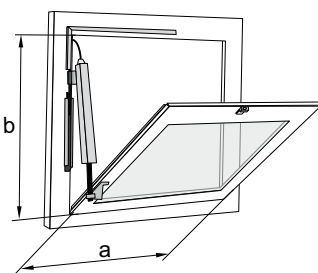

RWA 105E on side hung window

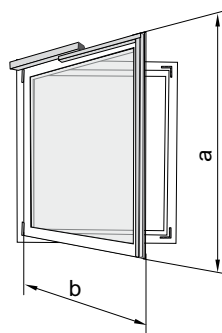

RWA 110E on top hung window

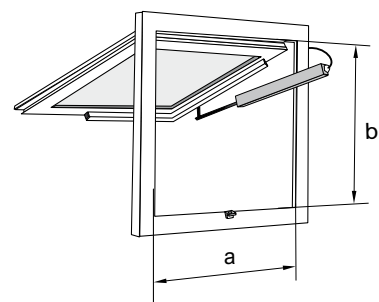

GEZE RWA 110E/Tandem opening and locking system

RWA system for inward-opening bottom hung, top hung and side hung windows

The RWA 100E system is available with four different stroke lengths and is used for natural smoke and heat extraction, smoke dissipation and the ventilation of inward-opening rectangular windows. The universal installation system enables use of all standard, vertically installed types of casements. High-quality components guarantee a long life.

GEZE RWA 100E



PRODUCT FEATURES

- The RWA 100E system consists of an electrically operated spindle drive E 250 VdS mounted on the surface of the profile, combined with a mechanical bracket set; available in four stroke lengths
- Suitable as a solo solution and as a tandem solution for wide casements – use of two RWA 100Es with the synchronised cut-off E102
- Achieves large opening widths with small spindle stroke in max. 60 seconds
- Mechanical locking at the main closing edge, possibility of use of a mechanical additional lock on the secondary closing edge on the motor side
- Suitable for installation in tested, certified GEZE SHEVs to EN 12101-2

ORDER INFORMATION – GEZE RWA 100E

Description	Version	Id. No.				
		Stroke 100 mm	Stroke 150 mm	Stroke 200 mm	Stroke 300 mm	
RWA 100E	silver	019726	019725	019724	021291	
	white RAL 9016	019745	019744	019743	021296	
	to RAL	019742	019741	019740	021295	
		L = 2000 mm			L = 3000 mm	L = 6000 mm
Rod ø 12 mm	galvanised	053198	053199	054116		
Cover profile (2000 mm and 3000 mm lengths, mitred on both sides)	silver	058771	058774	058630		
	white RAL 9016	018293	018294	018251		
	to RAL	014258	014259	013814		
Drilling template					014740	
Corner transmission OL 320					058648	
Additional lock OL 320	silver				063974	
	white RAL 9016				018257	
	to RAL				013080	
Additional lock OL 320 for secondary closing edges	silver				120297	
	white RAL 9016				120298	
	to RAL				120299	
Additional angle bracket for additional lock OL 320	silver				050727	
	white RAL 9016				015519	
	to RAL				013077	
Synchronised cut-off E102 / 24 V DC					101323	
Synchronising unit for electric drives 24 V					111198	

System RWA 100E and tandem RWA 100E – application areas

Profile-mounted system for vertically installed inward-opening bottom hung, top hung, angular and side hung windows. The main area of use is for inward-opening bottom hung windows.

RWA 100E

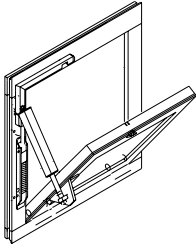

RWA 100E Tandem

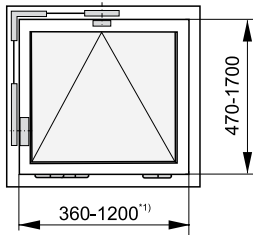
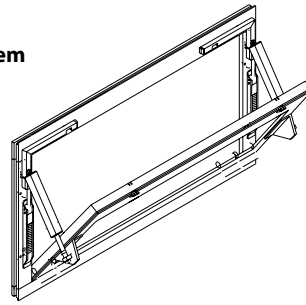

Bottom hung window

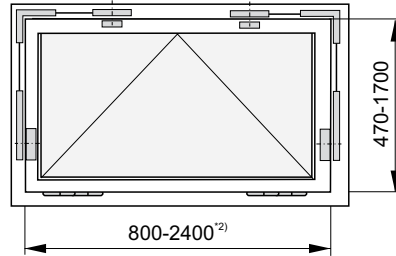

Bottom hung window

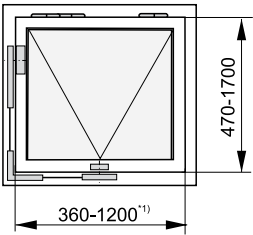

Top hung windows

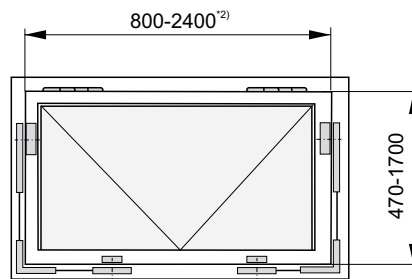

Top hung windows

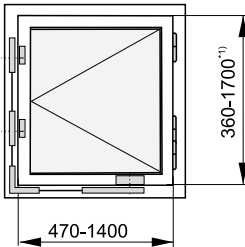

Side hung windows

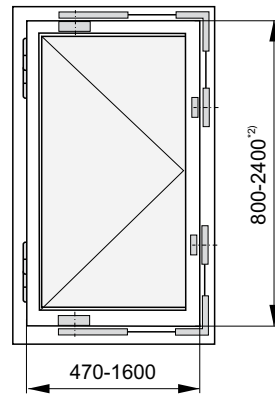

Side hung windows

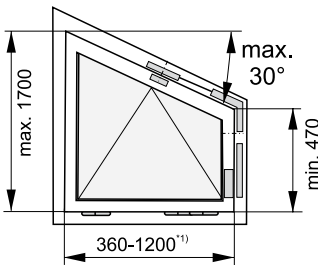

Angular windows
Bottom hung

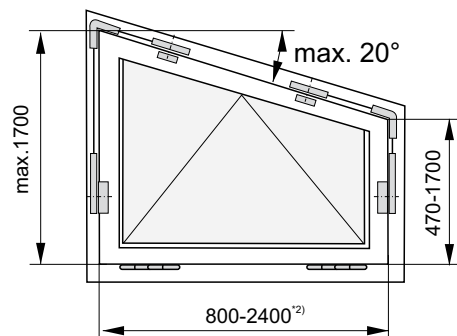

Angular windows

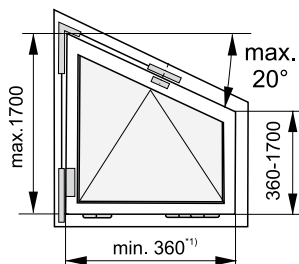

Angular windows
Bottom hung

System RWA 100E – system layout

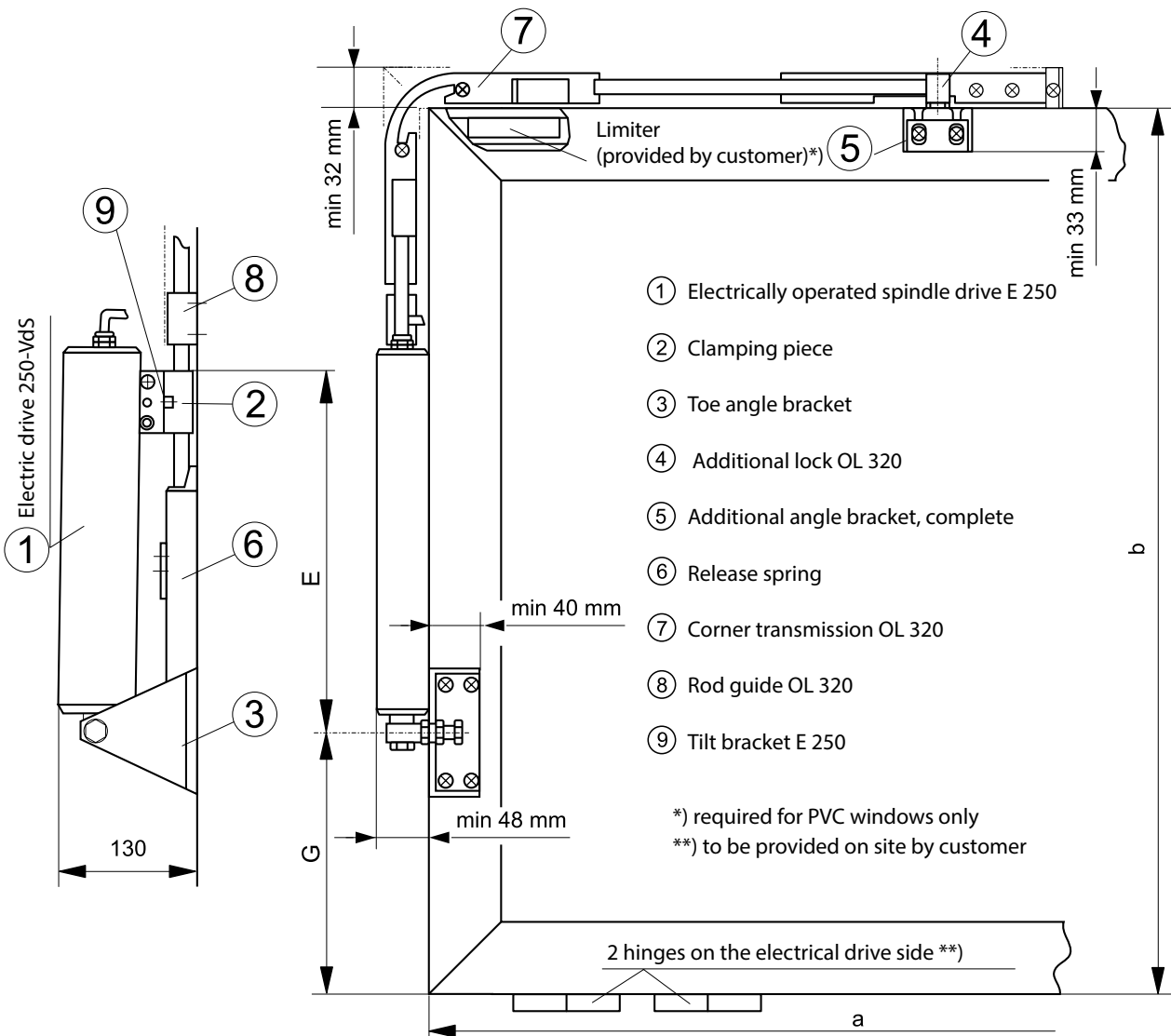

For fitting dimensions G and E, see installation instructions in RWA 100E packaging

Identification numbers of the installation drawings and wiring diagrams

RWA 100E		Drawing No.
Installation drawings	System	41521-EP-001

Determination of the motor stroke

RWA 100E and RWA 100E Tandem	Dimensions in [mm]										Stroke
	950-1000	1000-1050	1050-1100	1100-1150	1150-1250	1250-1320	1320-1400	1400-1500	1500-1600	1600-1700	
Caseмент height (dim. b)	950-1000	1000-1050	1050-1100	1100-1150	1150-1250	1250-1320	1320-1400	1400-1500	1500-1600	1600-1700	300
Opening angle [°]	approx. 52	approx. 48	approx. 48	approx. 44	approx. 40	approx. 38	approx. 35	approx. 32	approx. 29	approx. 27	
Opening width [mm]	approx. 860	approx. 820	approx. 860	approx. 840	approx. 830	approx. 850	approx. 820	approx. 800	approx. 780	approx. 750	
Caseмент height (dim. b)	700-800	800-900	900-1000	1000-1100	1100-1200	1200-1300					200
Opening angle [°]	approx. 50	approx. 44	approx. 40	approx. 33	approx. 28	approx. 25					
Opening width [mm]	approx. 640	approx. 640	approx. 650	approx. 600	approx. 570	approx. 540					
Caseмент height (dim. b)	560-630	630-700	700-800	800-900	900-1000						150
Opening angle [°]	approx. 51	approx. 46	approx. 37	approx. 35	approx. 27						
Opening width [mm]	approx. 520	approx. 520	approx. 490	approx. 490	approx. 450						
Caseмент height (dim. b)	470-520	520-600	600-700	700-800	800-850						100
Opening angle [°]	approx. 36	approx. 36	approx. 34	approx. 30	approx. 28						
Opening width [mm]	approx. 320	approx. 350	approx. 380	approx. 380	approx. 400						

The values given for the opening angle and opening width are guideline values only and can vary depending on the type of installation and fitting dimension G.

GEZE OPENING AND LOCKING SYSTEMS

GEZE RWA 105E/Tandem opening and locking system

RWA system for post & rail constructions

The RWA 105E system is available with three different stroke lengths and is used for natural smoke and heat extraction, smoke dissipation and ventilation. The universal installation system enables use on vertically installed post and rail constructions and inward-opening side hung windows – even in confined spaces. A particular advantage of this system is the double mechanical lock, the increased weathertightness and high degree of burglary protection.

GEZE RWA 105E



PRODUCT FEATURES

- RWA 105E, consisting of an electrically operated spindle drive E 250 VdS mounted on the surface of the profile, combined with a mechanical bracket set; available in three stroke lengths
- Suitable as a solo solution and as a tandem solution for wide casements – use of two RWA 105Es with the synchronised cut-off E102
- Achieves large opening widths with small spindle stroke in max. 60 seconds
- High-quality components guarantee a long life
- Mounted on the surface of the profile – motor attached to the window and does not protrude into the room
- Suitable for installation in tested, certified GEZE SHEVs to EN 12101-2

ORDER INFORMATION – GEZE RWA 105E

Description	Version	Id. No.		
		Stroke 100 mm	Stroke 150 mm	Stroke 230 mm
RWA 105E	silver	072657	073094	072652
	white RAL 9016	072661	073098	072656
	to RAL	072660	073097	072655
RWA 105E Tandem	silver	072667	073099	072662
	white RAL 9016	072671	073103	072666
	to RAL	072670	073102	072665
		L = 2000 mm	L = 3000 mm	L = 6000 mm
Rod ø 12 mm	galvanised	053198	053199	054116
Cover profile (2000 mm and 3000 mm lengths, mitred on both sides)	silver	058771	058774	058630
	white RAL 9016	018293	018294	018251
	to RAL	014258	014259	013814
Synchronised cut-off E102 / 24 V DC				101323
Synchronising unit for electric drives 24 V				111198
Rod guide				058653

System RWA 105E and tandem RWA 105E – application areas

Profile-mounted system for vertically installed, rectangular inward-opening bottom hung, top hung and side hung windows. The main area of use is for side hung windows in curtain walling.

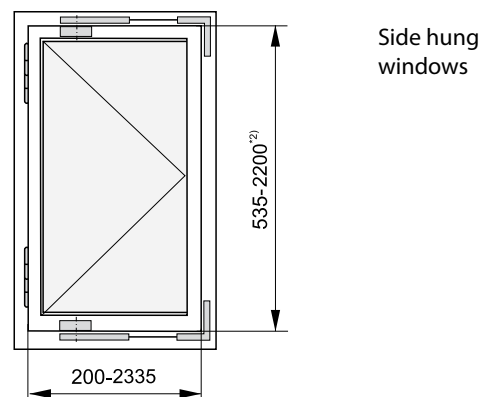
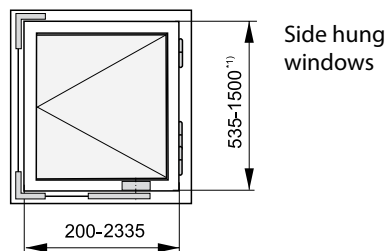
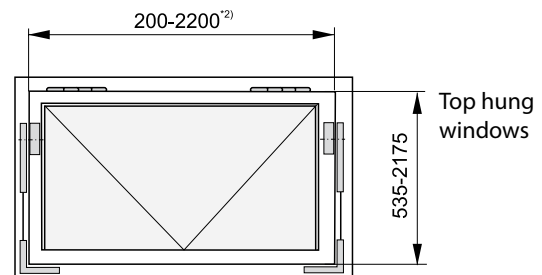
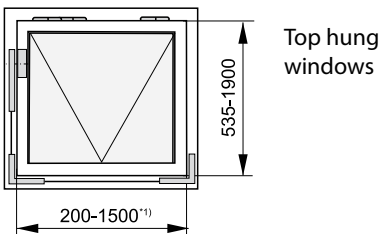
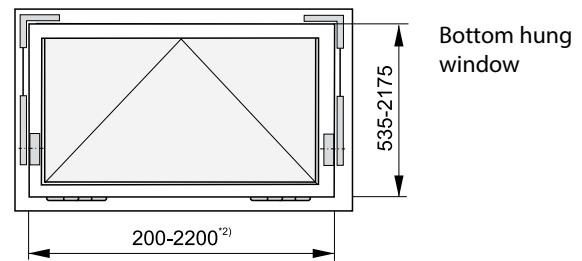
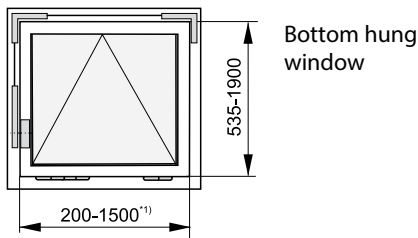
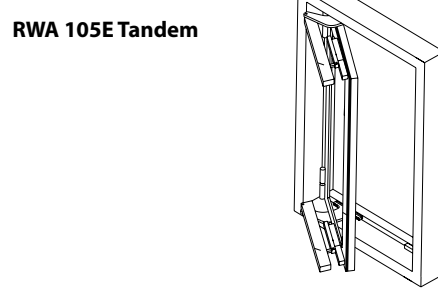
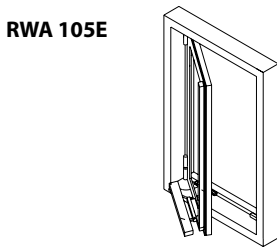

Dimensions in mm as standard; please contact GEZE if you require other dimensions

The details given are for wooden/aluminium windows; the following applies to PVC windows: ¹⁾ max 800 mm (Solo), max. 1600 mm (Tandem)

System RWA 105E – system layout

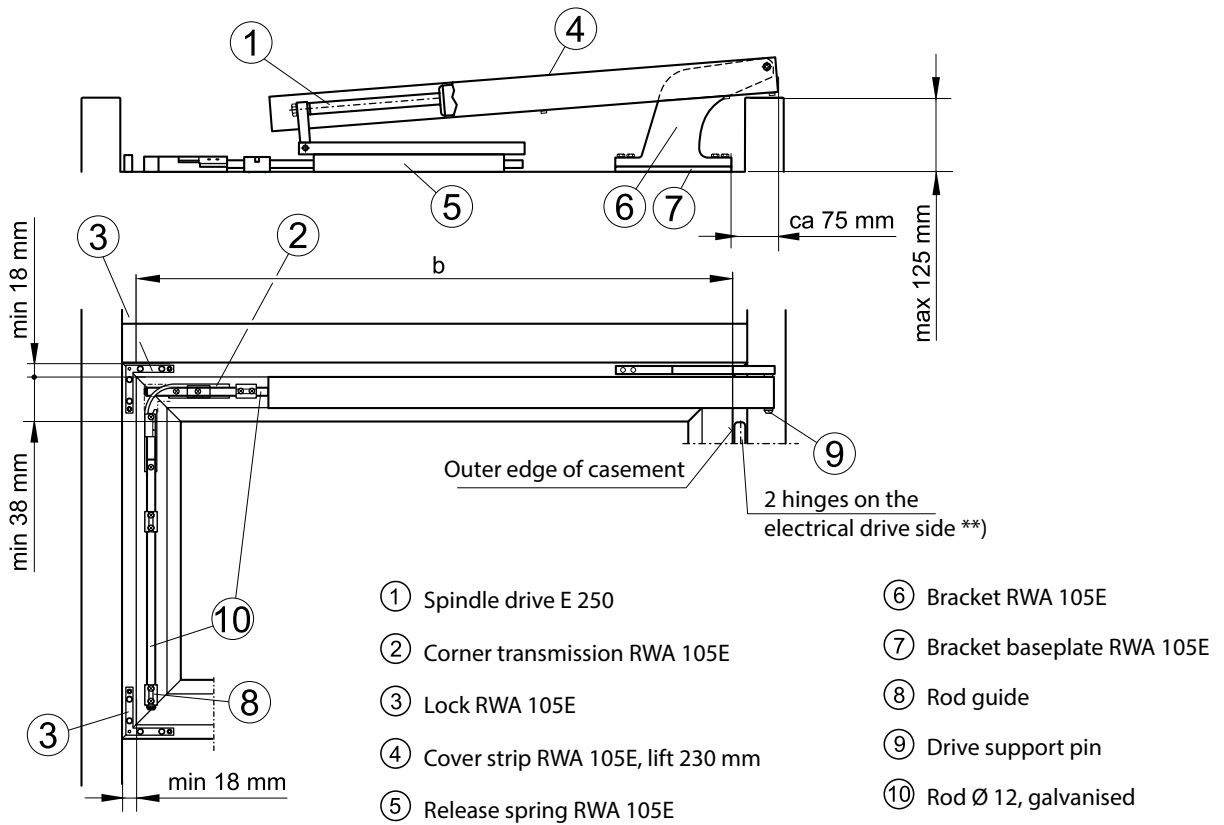

**) to be provided on site by customer

Identification numbers of the installation drawings and wiring diagrams

	RWA 105E	Drawing No.
Installation drawings	Solo	41523-EP-001
	Tandem	41523-EP-002

System RWA 105E – determination of the opening width

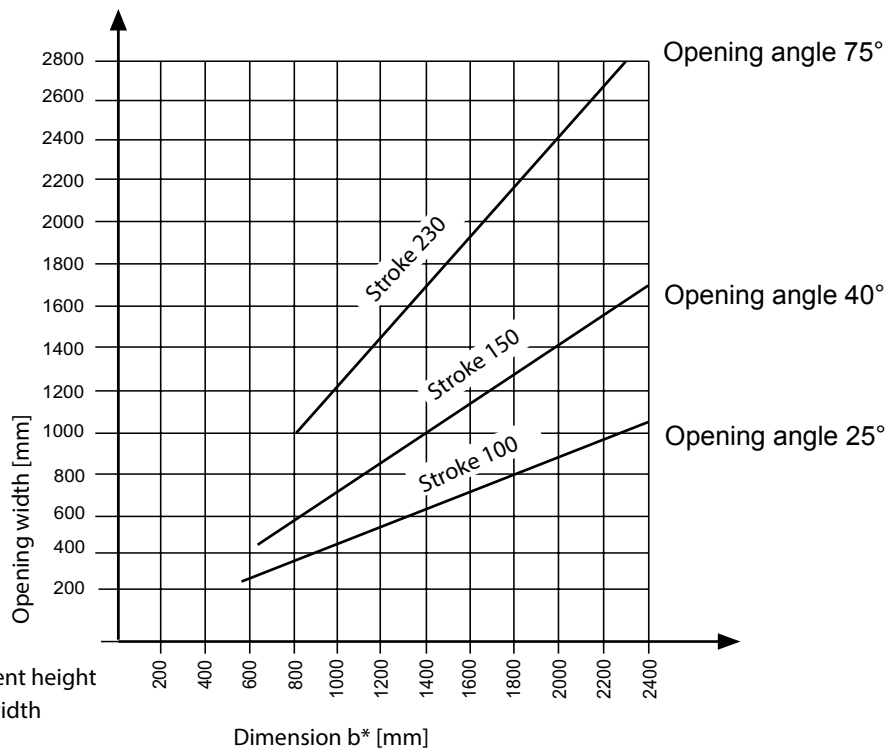

* Bottom hung casement: b = casement height
 * Side hung window: b = casement width

System RWA 105E – determination of the motor stroke

RWA 105E Solo

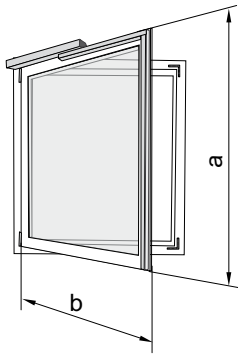

RWA 105E Tandem

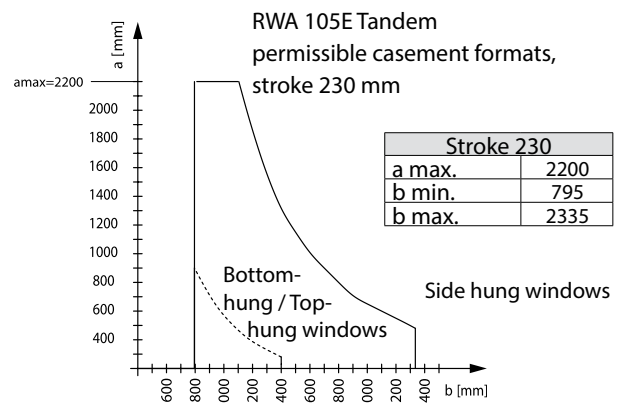
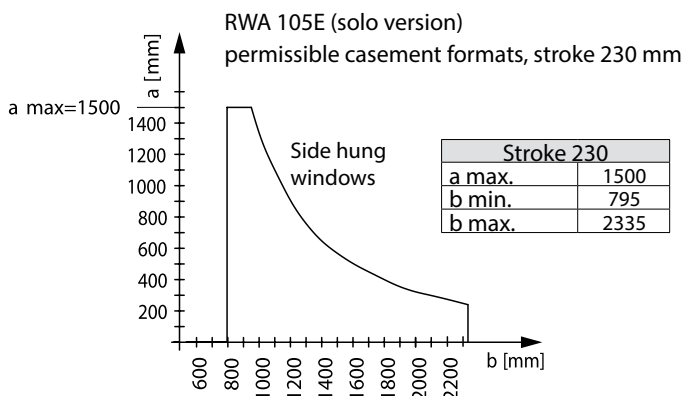
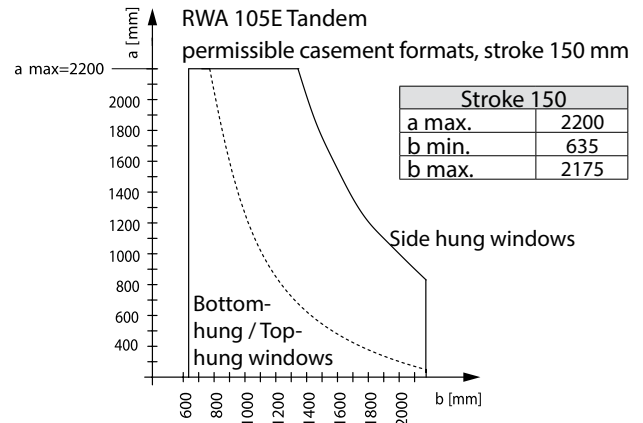
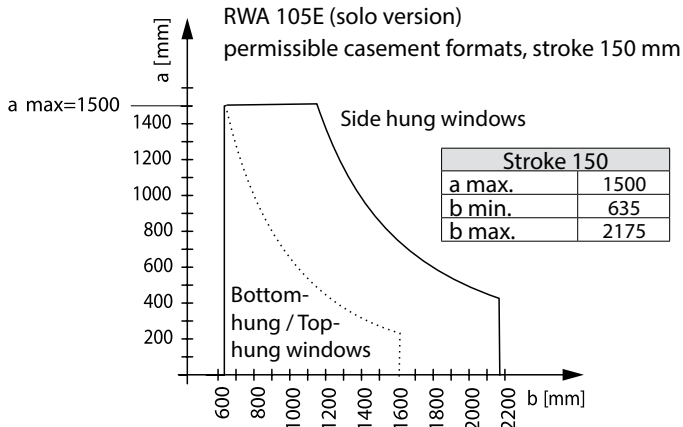
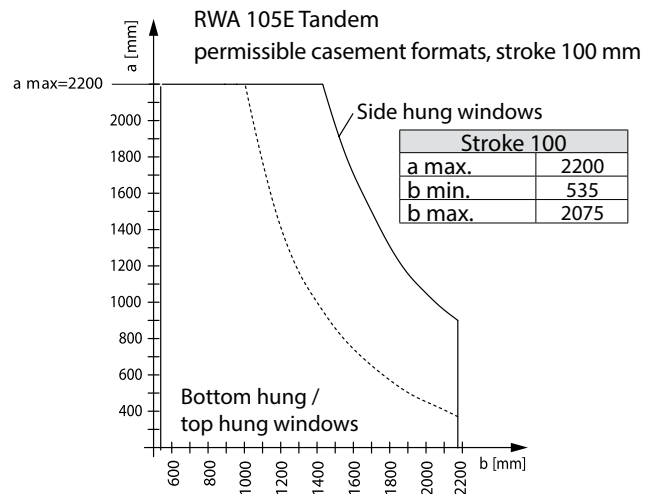
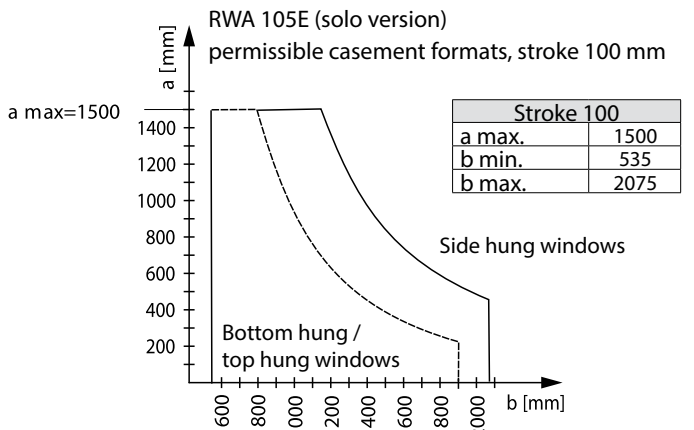
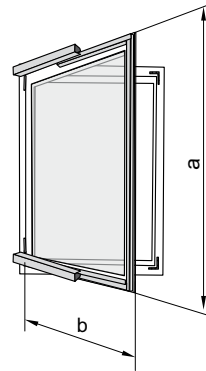

GEZE OPENING AND LOCKING SYSTEMS

GEZE RWA 110E/Tandem opening and locking system

RWA system for outward-opening bottom hung, top hung and side hung windows

The RWA 110E system is available with three different stroke lengths and is used for natural smoke and heat extraction, smoke dissipation and the ventilation of outward-opening windows. The universal installation system enables use of all standard, vertically installed types of casements. High-quality components guarantee a long life.

GEZE RWA 110E



PRODUCT FEATURES

- RWA 110E, consisting of an electrically operated spindle drive E 250 VdS, mounted on the surface of the profile, combined with a mechanical bracket set; available in three stroke lengths
- Suitable as a solo solution and as a tandem solution for wide casements – use of two RWA 110Es with the synchronised cut-off E102
- Achieves large opening widths with small spindle stroke in max. 60 seconds
- Mounted on the surface of the profile – the motor is attached to the window and does not protrude into the room
- Mechanical lock on the main closing edge
- Suitable for installation in tested, certified GEZE SHEVs to EN 12101-2

ORDER INFORMATION – GEZE RWA 110E

Description	Version	Id. No.	Id. No.	Id. No.	Id. No.
		Stroke 150 mm	Stroke 200 mm	Stroke 300 mm	
RWA 110E	silver	020559	020552	021303	
	white RAL 9016	020567	020558	021311	
	to RAL	020564	020556	021310	
		L = 2000 mm	L = 3000 mm	L = 6000 mm	
Rod ø 12 mm	galvanised	053198	053199	054116	
Cover profile (2000 mm and 3000 mm lengths, mitred on both sides)	silver	058771	058774	058630	
	white RAL 9016	018293	018294	018251	
	to RAL	014258	014259	013814	
Synchronising unit for electric drives 24 V					111198
Corner transmission OL 320					058648
Additional lock OL 320	silver				063974
	white RAL 9016				018257
	to RAL				013080
Additional angle bracket for additional lock OL 320	silver				050727
	white RAL 9016				015519
	to RAL				013077
Synchronised cut-off E102 / 24 V DC					101323

System RWA 100E and tandem RWA 100E – application areas

Profile-mounted system for vertically installed, outward-opening bottom hung, top hung and side hung windows.

RWA 110E

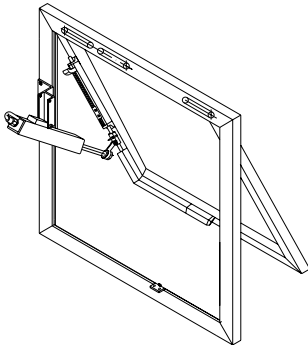

RWA 110E Tandem

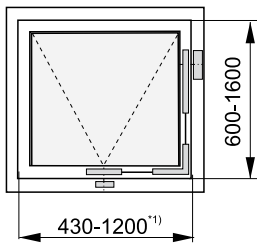
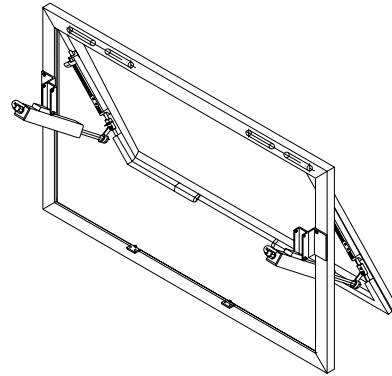

Top hung windows

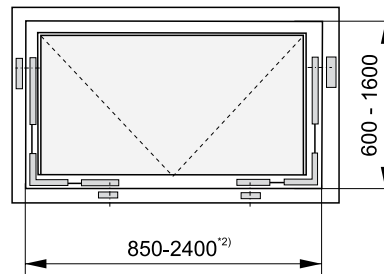

Top hung windows

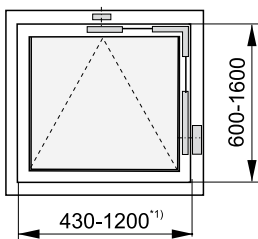

Bottom hung window

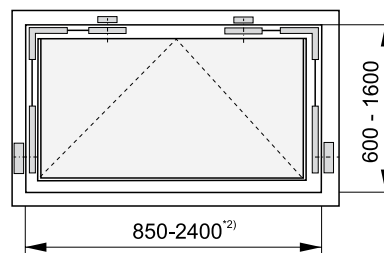

Bottom hung window

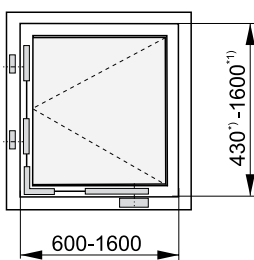

Side hung windows

¹⁾ min 800 for 2 locks

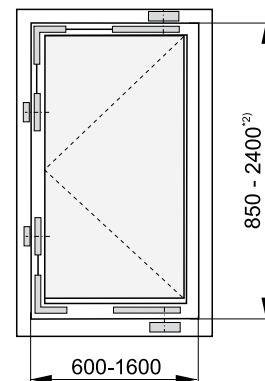

Side hung windows

System RWA 110E – system layout

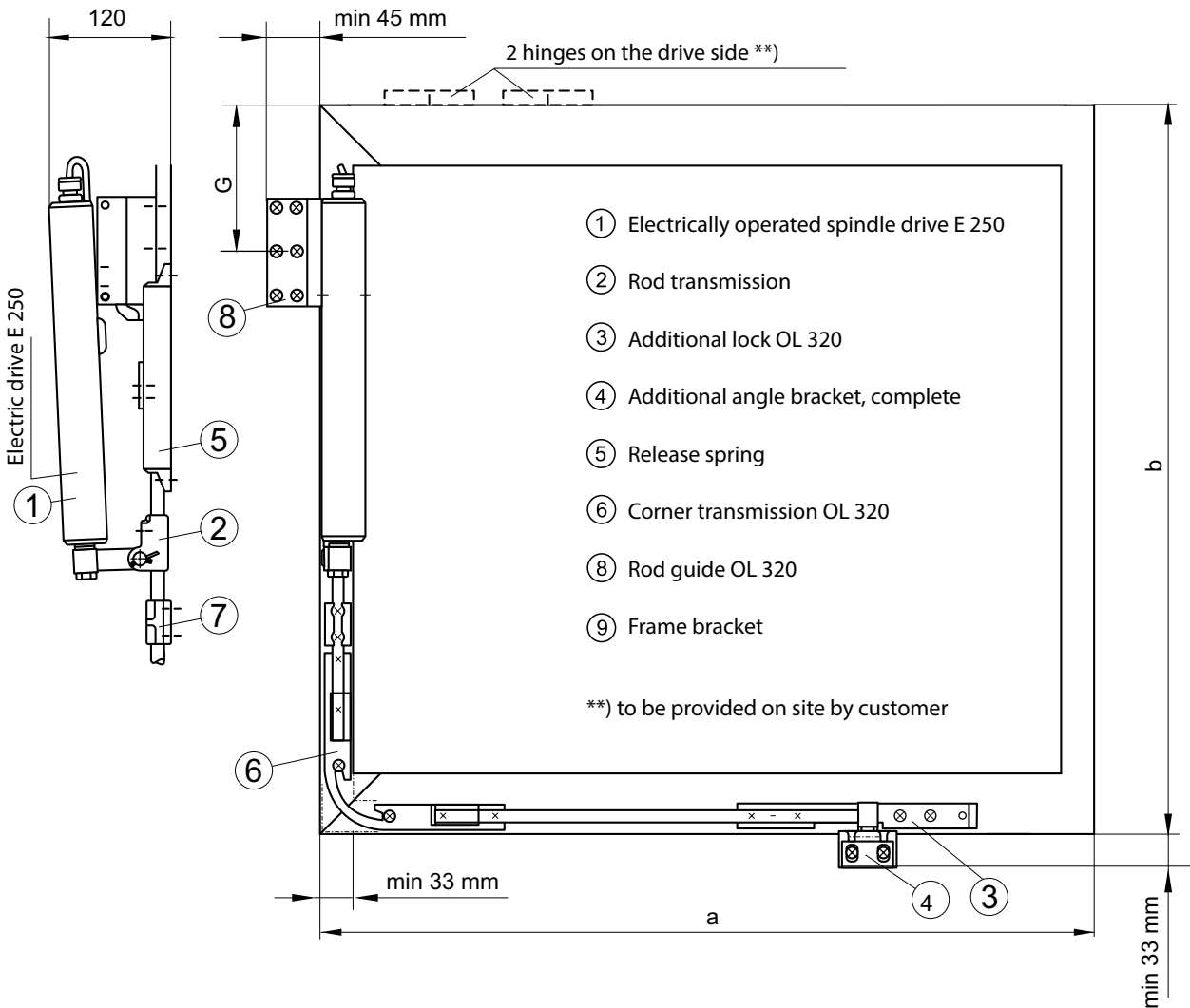

Identification numbers of the installation drawings and wiring diagrams

RWA 110E		Drawing No.
Installation drawings	Outward-opening system	41521-EP-002

Determination of the motor stroke:

RWA 110E and RWA 110E Tandem										Stroke	
Dimensions in [mm]											
Casement height (dim. b)	900-920	920-950	950-1000	1000-1050	1050-1100	1100-1200	1200-1300	1300-1400	1400-1500	1500-1600	E 250/ E 300
Opening angle [°]	approx. 56	approx. 54	approx. 51	approx. 49	approx. 47	approx. 43	approx. 39	approx. 35	approx. 33	approx. 31	
Opening width [mm]	approx. 880	approx. 870	approx. 870	approx. 880	approx. 880	approx. 860	approx. 860	approx. 830	approx. 840	approx. 840	
Casement height (dim. b)	650-700	700-750	750-800	800-850	850-900	900-950	950-1000				E 250/ E 200
Opening angle [°]	approx. 55	approx. 51	approx. 48	approx. 46	approx. 43	approx. 41	approx. 39				
Opening width [mm]	approx. 640	approx. 650	approx. 650	approx. 670	approx. 670	approx. 670	approx. 670				
Casement height (dim. b)	600-650	650-700	700-750	750-800	800-850						E 250/ E 150
Opening angle [°]	approx. 45	approx. 44	approx. 42	approx. 39	approx. 37						
Opening width [mm]	approx. 510	approx. 530	approx. 540	approx. 540	approx. 540						

The values given for the opening angle and opening width are guideline values and can vary depending on the type of installation and fitting dimensions G.

GEZE electric linear drives E 212 and E 205

Electric linear drives for use in conjunction with slimline fanlight openers

The GEZE flat fanlight openers can be electrically activated in conjunction with the E 212 and E 305 electric motors. Therefore, cost-effective and simple motorised solutions result for activating several scissor stays where several heavy windows exist. In addition, the drives are also ideally suited for the activation of louvre windows. The narrow design allows elegant adaptation to window frontages.

GEZE E 212/E 205



GEZE electric linear drive E 212



GEZE electric linear drive E 205

Dimensioned drawing E 212

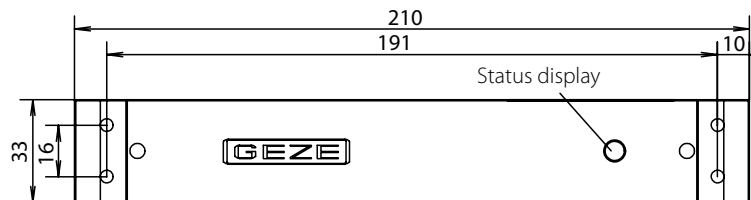

Dimensioned drawing E 205

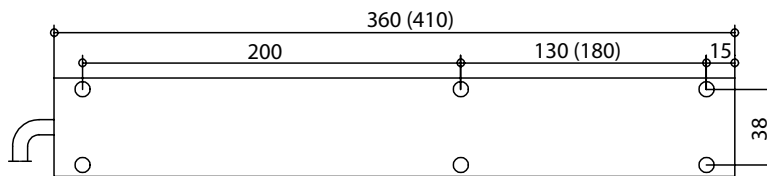

PRODUCT FEATURES

- In combination with the slimline fanlight opener OL 320, OL 90 N and OL 95 the electric linear drives can be used for smoke dissipation and ventilation
- Completely pre-assembled module; simple installation on the left, right, horizontally and vertically with external, concealable screws
- Small space requirement above the casements and to the side of them
- Limit switch and drive protection (self-locking thermal latch integrated in the winding) installed and adjustable
- Adjustable spindle stroke; activation via emergency power control unit
- The electric linear drives are also suitable for louvre windows

ORDER INFORMATION – GEZE ELECTRIC LINEAR DRIVES

Description	Version	Id. No.
Electric linear drive E 212/24 V DC Power consumption 1.2 A	EV1	010899
	white RAL 9016	015540
	to RAL	010915
Electric linear drive E 205/24 V DC Power consumption 1.9 A	silver	056041
	white RAL 9016	027096
	to RAL	027095
Connection parts for E 205, rod and coupling with OL 90 N		030870
Synchronising unit for electric drives 24 V		111198
Safety scissor stay No. 60		133814
Safety scissor stay No. 35	Galvanised steel	014499
Drilling template for metal and PVC		010881

Fanlight opener system with electric linear drive E 212 or E 205

Application area – slimline fanlight opener OL 320

- Surface-mounted slimline fanlight opener for vertically installed bottom hung, top hung and horizontally pivot hung casements
- Inward-opening casements, can be used on the left and right
- Casement weights according to the application diagrams
- Locking device in the scissor stay
- Only one casement bracket for all projection sizes and materials, i.e. simple installation
- Completely pre-assembled modules, therefore few fitting parts
- Small space requirement above the casements and to the side of them
- All visible parts made from lightweight metal

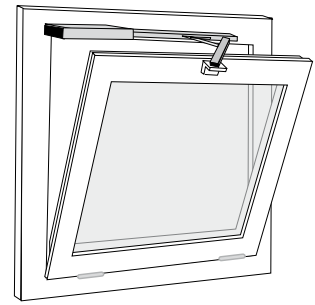

Opening width approx. 300 mm with stroke 66 mm (standard), approx. 220 mm with stroke 42 mm (on request)

Technical data	E 212	E 205
Dimensions (height x width x length)	30 x 80 x 210 mm	52 x 70 x 360 mm
Adjustable stroke	42 – 66 mm	42 – 70 mm
Tensile and compressive force	1500 N	2000 N
Running time (under load)	approx. 35 sec for 52 mm stroke	approx. 45 sec for 70 mm stroke
Temperature range	-20° to +70° C	-20° to +70° C
Power consumption	29 W	30 W
Power consumption	1.2 A	1.9 A
Protection type	IP 52	IP 54
Operating voltage	24 V DC	24 V DC
Cables	Plug-in version	3 x 1.5 mm ²

Area of application

- Can be used vertically or horizontally, on the left or right of the window
- Electrically operated spindle drive suitable for dry rooms only
- Permissible casement projection height 0–25 mm

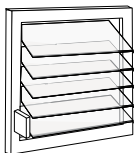

Drives can also be used for louvre windows.
Further information available on request.

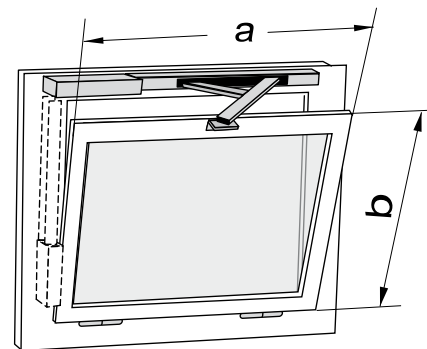

Number of scissor stays required	E 212		E 205	
	Casement width a for horizontal installation	Casement width a for vertical installation	Casement width a for horizontal installation	Casement width a for vertical installation
1 scissor stay	800-1200 mm	600-1200 mm	850-1350 mm	600-1200 mm
2 scissor stays	1201-2400 mm	1201-2400 mm	1351-2400 mm	1201-2400 mm
3 scissor stays	2401-3600 mm	○	2401-3600 mm	2401-3600 mm
4 scissor stays	○	○	3600-4800 mm	○
5 scissor stays	○	○	4801-5400 mm	○
	Casement height b min. 400 mm ¹⁾	Casement height b min. 500 mm ²⁾	Casement height b min. 400 mm ¹⁾	Casement height b min. 540 mm ²⁾

○ = no

¹⁾ If the opening width is limited to 190 mm by the motor stroke, b min. = 290 mm

²⁾ If there is no bottom reveal, b min. = 400 mm

Note:

If installed on bottom hung casements, for product liability reasons, we specify the installation of separate safety scissor stays. These are an additional safety device which ensures permanent connection between the casement and frame, e.g. GEZE FPS gripping and cleaning scissor stay.

Permissible casement width and panel weight depending on the “i” dimension

(for installation with OL 320)

i = Distance between the casement centre of gravity and the hinge pivot point [mm]

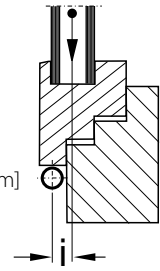

Horizontal installation - E 212

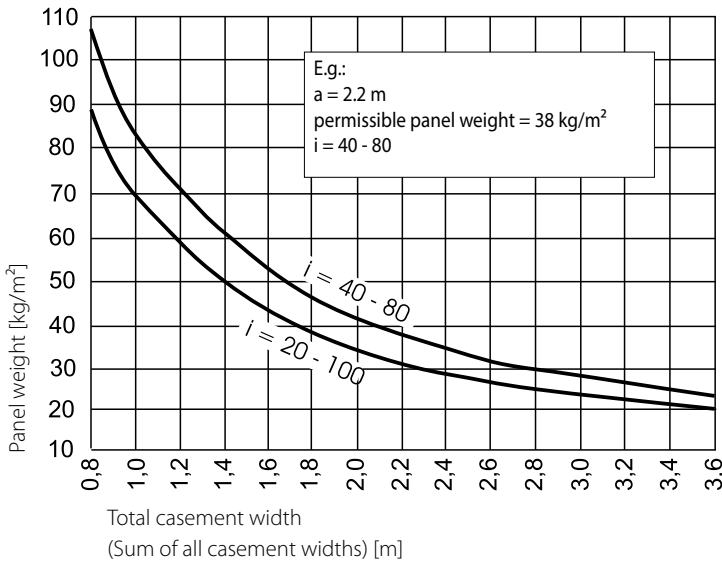

Vertical installation - E 212

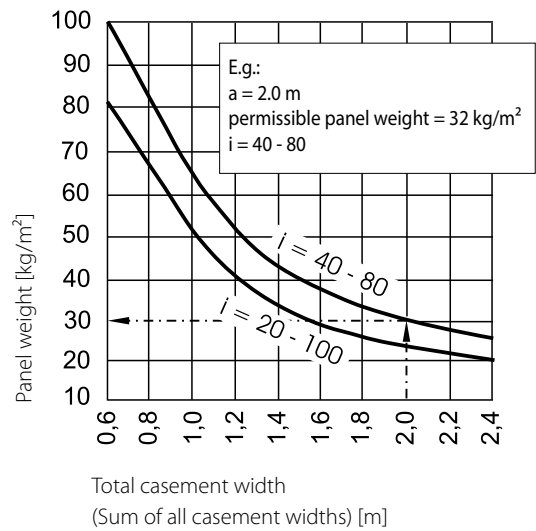

Horizontal installation - E 205

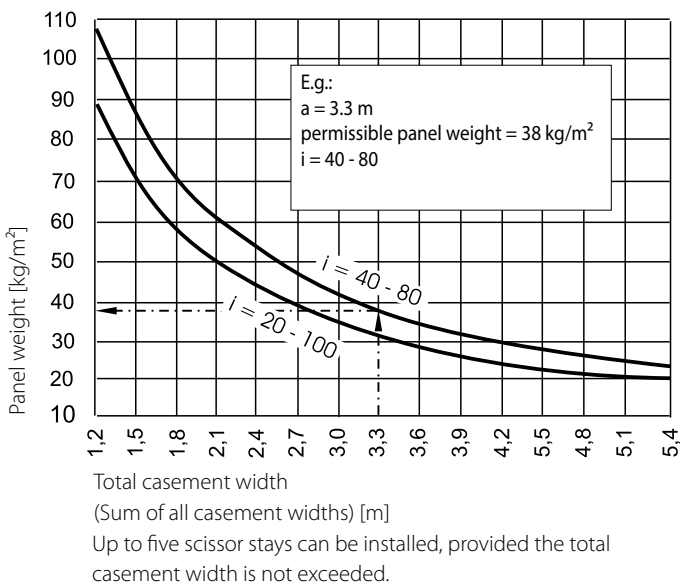

Vertical installation - E 205

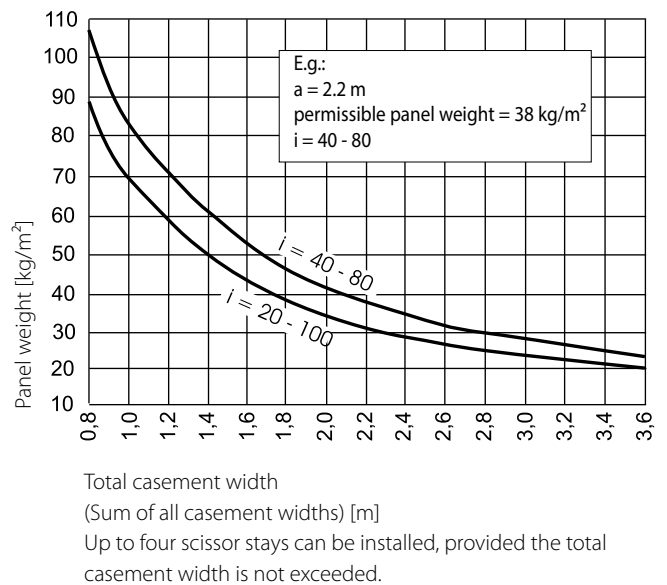

Identification numbers of the installation drawings and wiring diagrams

	Electric linear drive E 212	Drawing No.	Electric linear drive E 212	Drawing No.
Installation drawings	Horizontal installation	40408-EP-030	Horizontal installation	40408-EP-003
	Vertical installation	40408-EP-029	Vertical installation	40408-EP-002
Wiring diagrams		45109-9-0956	Installation on post & rail construction	40408-0-031
				45109-9-0955

GEZE RWA TÖ fresh air

Combination of door closer and RWA control unit

This system provides the option of using a door as an RWA fresh air opening and therefore of creating a large fresh air inlet area relatively quickly. In rooms with no or too small windows or flaps – e.g. to a roof garden, terrace or balcony – the door can be used in conjunction with the RWA TÖ system as a smoke extraction opening.

The RWA TÖ system combines a door closer with RWA control unit and the relevant accessories. Released by the emergency current control unit, in the RWA case this door is opened by the force of the inversely mounted door closer. Equipped with the GEZE motor lock IQ Lock EL or the emergency exit opener 331, this version can also be used as an emergency exit door.

GEZE RWA TÖ



System arrangement

The following components are required for this system:

In the lock area

- ① An electrical door opener model 14 Fafix KL 24 V AC
- ② Door lock and door handle (are not directly part of the RWA system and must be supplied by the door manufacturer)

On the door lintel

- ③ One door closer TS 4000, TS 4000 EFS or TS 5000 in special installation

In the area of the door or in an ancillary room

- ④ One control unit E 10/24 V
- ⑤ One emergency power control unit THZ, THZ Comfort, E 260 N/24 V DC, MBZ 320

In the stairway

- ⑥ RWA pushbutton FT4 for actuating alarm (Quantity and arrangement according to the building control authorities)
- ⑦ One or several smoke detectors (mounted on the ceiling) for automatic actuation

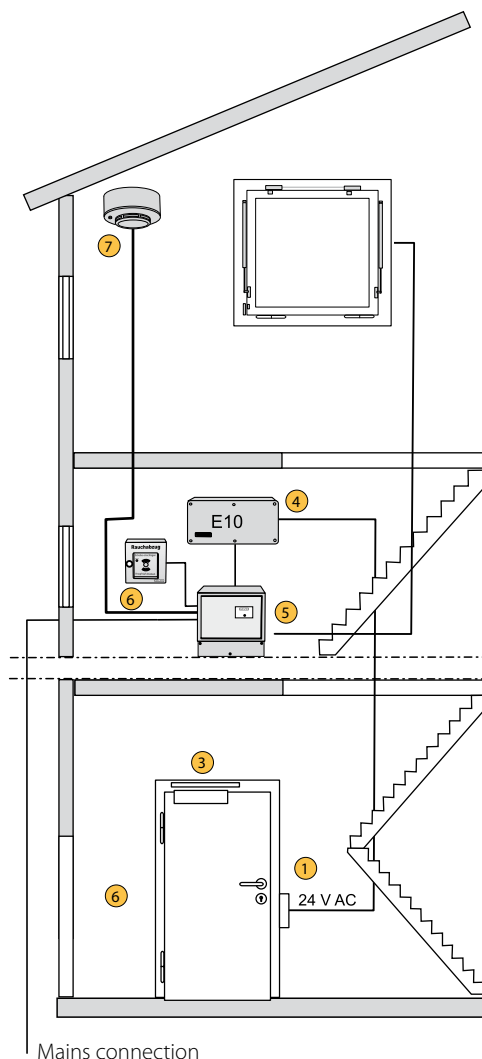

GEZE RWA TÖ fresh air - description of function

Opening the door/emergency

▪ **Manual:**

The door opener is unlocked by pressing an RWA pushbutton FT4 or other pulse generator. The spring-tensioned door closer opens the door. The door can be opened with the door handle without activating the smoke and heat extraction systems.

▪ **Automatic:**

By operating the smoke and heat detector, a pulse is sent to the door opener and it releases the door. Door opening angle limited to approx. 90° (otherwise damage to closer is possible).

Manual closing of the door/alarm reset

The alarm is reset using the reset button of the RWA pushbutton FT4 and the associated unlocking of the pushbutton or, if released via a smoke and heat detector, by resetting the detector. The door must then be closed by hand by pushing against the pressure of the door closer connected as a door opener. If the power supply in the building is not secured by an emergency generator, this must be ensured via an emergency power supply.

Technical data

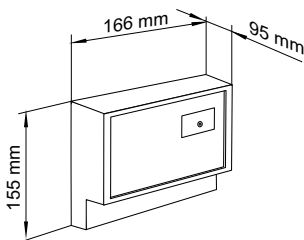

Control unit E10	
Plastic housing	
Pre-assembled ready to connect unit	
matched to the power required by the 24 V DC door opener	
Output power	max. 1 A
Input voltage	24 V DC
Output voltage	24 V DC time limit timed to 10 s

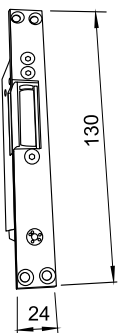

Door opener model 14 Fafix 24	
Door opener with short flat strike plate	
Latch release, matched to latch and bolt, the door lock and the door construction	
reliable, fail-safe unlocking of the door latch with operating current	
Adjustment range	max. 4 mm
Frame dimension	min. 44 mm
Nominal voltage	24 V AC ±15%
Power consumption	400 mA ±15%
ON period	max. 1 min.
can be used on the left and right	

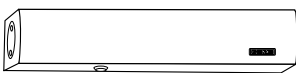

Door closer TS 4000, TS 4000 EFS or TS 5000 in special installation	
opens the door when the system is released, as soon as the door opener is unlocked	
with guide rail and lever	
adjustable opening force	
controllable opening damping	
safety valve	
for inward and outward-opening doors	



RWA pushbutton FT4 - release button	
lockable door	
with viewing panel	
Indicator lights for "Window open", "Alarm", "Fault" and "Operation OK"	
in colours: orange, red, blue and grey	

Technical data

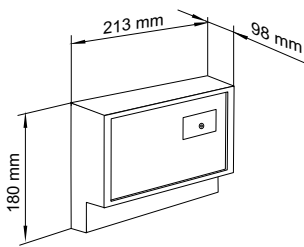

Emergency power control unit E 260 N 24 V DC	
automatic changeover to battery operation in the event of a power failure	
Mains voltage 230 V AC, 50 Hz	
with control diode in the front panel	

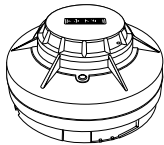

Heat differential detector type WM 1005	
Operating voltage:	8 V to 30 V
Dimensions:	ø 102 x 50 mm



Smoke detector type RM 1003 24 V DC	
Operating voltage:	8 V to 30 V
Dimensions:	ø 102 x 42 mm

Activation and supply via the emergency power control unit E 260 N2-N32

It functions in the same way as the standard RWA with electric drive, i.e. connection via the required motor group. The E10 control units are supplied with 24 V DC and activated via the emergency power control units (max. five E10 control units per group, taking into account the total current).

The output power of the E10 control unit is 1 A. Therefore, max. two Fafix door openers are possible with each E10. In the event of an alarm (window OPEN), the Fafix door opener is active (open-circuit principle).

The alarm of the door opener is actuated by the emergency power control unit E 260 N

- manually using RWA pushbutton FT4 and/or
- automatically via smoke detector RM 1003 or heat differential detector WM 1005
- retriggering in case of an alarm causes activation every 2 minutes

Central alarm actuation via the local fire alarm system (BMA) or a central pushbutton for several E10 control units

The alarm signal is connected via a potential-free switch contact to the supply line of the emergency power supply to the first E10 control unit, i.e. at rest the contact must be open (break contact) and in the event of an alarm it must close (make contact). The alarm is then looped through to all E10 control units connected in series (up to 10 maximum).

Further information about the actuation options listed in the following is available on request:

- Actuation via pushbutton input through potential-free make contact of the BMA provided on site by the customer
- Actuation via smoke switch input through potential-free break contact of the BMA provided on site by the customer
- Actuation via local pushbutton or smoke switch and a further central switch for all E10 control units connected in series
- Actuation via a local pushbutton and via a further central key-operated switch and/or BMA remote release
- Actuation via a central pushbutton as circuit-breaker

RWA-EL TÖ "OPEN" on a double-leaf door

The functional options of the double-leaf version are the same as those in the cases described above. The fixed leaf must open later to ensure that both leaves of a double-leaf door are not opened at the same time, causing them to get caught. This can also be achieved by a time relay or the GEZE activation delay block LEV, upstream of the E10 control unit.

Combination with the GEZE escape route system (RWS)

The function is similar to that of the standard version. An inverse type door closer (with preloaded spring) and an electrical retention magnet (MA 500 with reed contact) is installed on the door. The retention magnet is continuously supplied with current and keeps the door closed against the spring force of the door closer (closed-circuit principle).

The retention magnet is activated and supplied via an RWS door control unit. In a panic case, the door control unit is released directly by pressing the emergency button. The door control unit is connected to an RWA E 260 N emergency power control unit (relay alarm) via a potential-free break contact. In the case of a fire, the alarm is actuated and the magnet is released by pressing an RWA pushbutton (manual release) or smoke switch (automatic release). The door is then opened by the spring force of the door closer.

In this system, the door control unit can also be unlocked and the door passed through using a key-operated switch. After passing through the door it must be re-closed manually, against the spring force of the door closer.

In the event of short-term release, automatic locking is possible after closing the door (a so-called discontinuation), i.e. the door only has to be pressed shut and locks automatically, as soon as the door leaf is closed.

Note: For further information on the RWS function and the door control units, please refer to the GEZE SecuLogic documents.

Combination with TS 4000 EFS

(Invers version/for convenient passing through the door in normal operation)

The Freeswing door closer TS 4000 EFS (in special installation for the RWA-EL-TÖ "OPEN" system) in inverse activation enables the user to conveniently pass through the door in routine operation.

In case of fire the door opens automatically (by manual or automatic activation), to ensure smoke extraction.

Manual:

- Emergency: The door opener is unlocked by pressing a pushbutton or other pulse generator. The spring-tensioned door closer opens the door (Freeswing function is deactivated).
- Normal operation: The door can be opened with the door handle.

Automatic:

- By operating the smoke and heat detector, a pulse is sent to the door opener and it releases the door; the door opens (Freeswing function is deactivated).

Closing the door:

- Following emergency: The pressed button and/or smoke and heat switches must be reset. The door must then be closed by hand by pushing against the pressure of the door closer connected as a "door opener".

Note: Combination with the GEZE MLS motor lock is possible. Please contact GEZE GmbH for details.

GEZE retractable arm drive RWA K 600

Retractable arm drive for opening doors and windows

The RWA K 600 provides possible solutions if large opening angles are to be generated at doors and windows. A programmable opening angle of up to 93° enables the elements to be opened to 90° depending on which side the door opens (left/right). The retractable arm drive can be installed with freely supported, unrestrained lever arm or with fixed connection to the door or window casement. The drive sits in the lintel, on the frame or the casement. In the unrestrained surface-mounted installation the RWA K 600 can be combined with GEZE door closers and is therefore ideal for air inlet openings with high passage convenience. The combination of RWA K 600, motor lock and door closer is the single source solution for air inlet openings with lock suitable for insurance requirements.

GEZE RWA K 600



PRODUCT FEATURES

- Microprocessor controlled drive – available as solo and synchronous version with real synchronous control; synchronised multiple operation without additional module
- Electrically controlled soft start and soft stop
- Integrated status contact can be used to connect a door opener
- Max. power consumption 1.4 A · Torque 215 Nm · Tensile and compressive force max. 600 N

AREA OF APPLICATION

- Doors: hinge and counter-hinge side installation for free passage or with fixed connection
- Inward and outward-opening bottom hung, top hung and side hung windows and skylights



GEZE RWA K 600 G



GEZE RWA K 600 T



GEZE RWA K 600 F

ORDER INFORMATION – GEZE ELECTRIC LINEAR DRIVES

Description	Version	Id. No.
RWA K 600 G retractable arm drive with a guide rail for fixed connection of the retractable arm	EV1	130057
	Special version*	130058
	Syncro*	133119
RWA K 600 T retractable arm drive for freely supported, unrestrained installation with a roller on the retractable arm	EV1	130059
	Special version*	130060
	Syncro*	133120
RWA K 600 T retractable arm drive with an articulated lever for fixed connection of the retractable arm	EV1	130151
	Special version*	130152
	Syncro*	133221
RWA K 600 bracket T		130153
RWA K 600 bracket R		130154

* Configurable ID numbers

GEZE RWA K 600 F retractable arm drive

The RWA K 600 F retractable arm drive can be used both on doors and on windows. In general it can be installed on the hinge side, side opposite to hinge possible on request. The door cannot be freely passed through due to the fixed connection of the drive with one door leaf.

AREA OF APPLICATION

Type of installation	Window, hinge side	Door, hinge side
Max. leaf weight	30/40 kg/m ²	250 kg ²⁾
Max. leaf/casement width ¹⁾ HSK	800 mm solo, 1200 mm syncro	1600 mm ²⁾ solo
Min. leaf/casement width HSK	○	355 mm
Max. leaf/casement height ²⁾ NSK	2x + 750 mm	○
Max. leaf/casement height NSK	x + 420 mm	○
Brackets	Bracket R and articulated lever bracket	Bracket R and articulated lever bracket
Min. space requirement on the frame	top 45 mm, side 55 mm	45 mm
Min. space requirement on the casement	depends on the hinge centre spacing	

¹⁾ A lock is necessary for larger leaf/casement widths

²⁾ Higher values available on request

Hinge-side installation on the door – fitting dimensions

Plan view

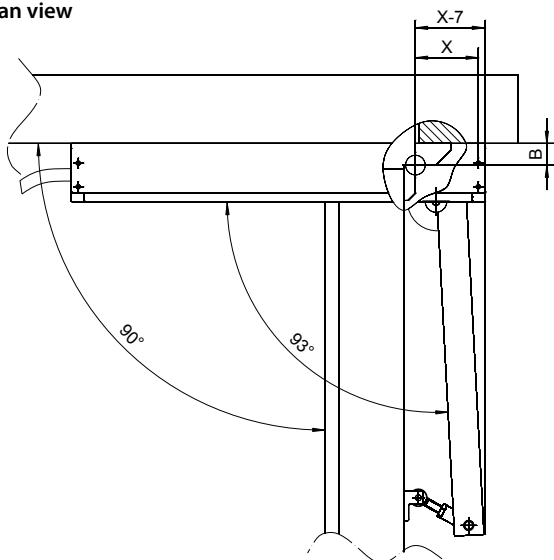

Head point detail

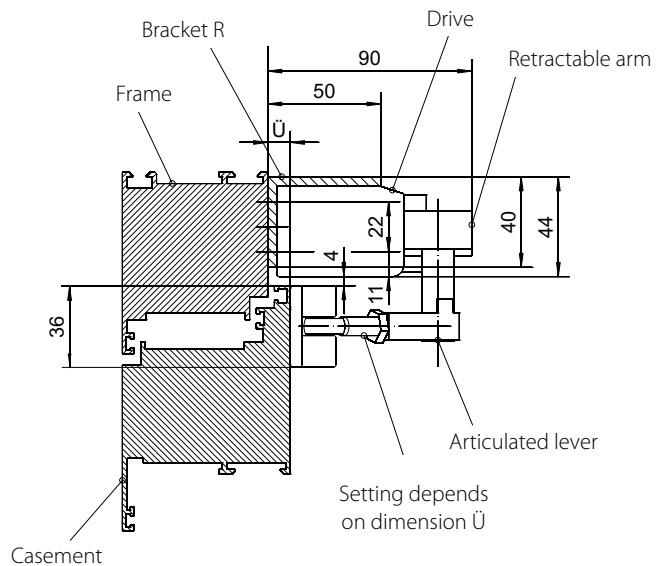

Installation of bracket R / bracket for articulated lever

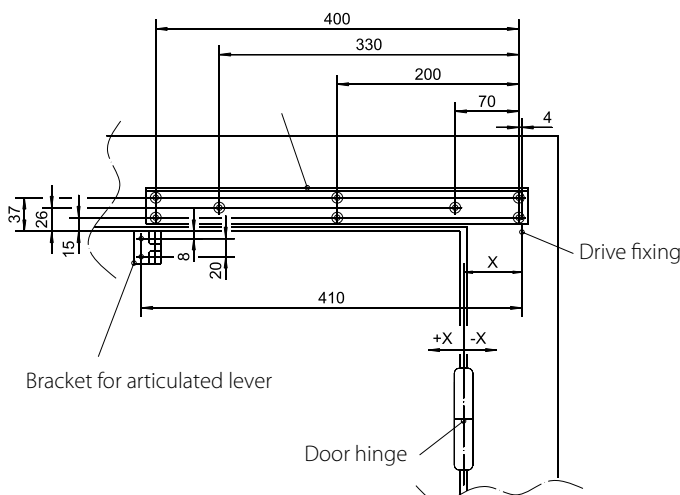

X = Distance of door hinge from the drive fixing

B = Hinge centre spacing

Ü = Leaf/casement projection beyond frame
(if Ü < 10 mm: use baseplate with bracket for articulated lever = Ü + baseplate = 10 mm)

Determination of the X dimension with opening angle $\alpha = 90^\circ$:

Examples:

B	X dimension for $\alpha = 90^\circ$
22	-55
36	-50

Different opening angles / hinge centre spacings available on request.

Hinge-side installation on window – fitting dimensions

Plan view

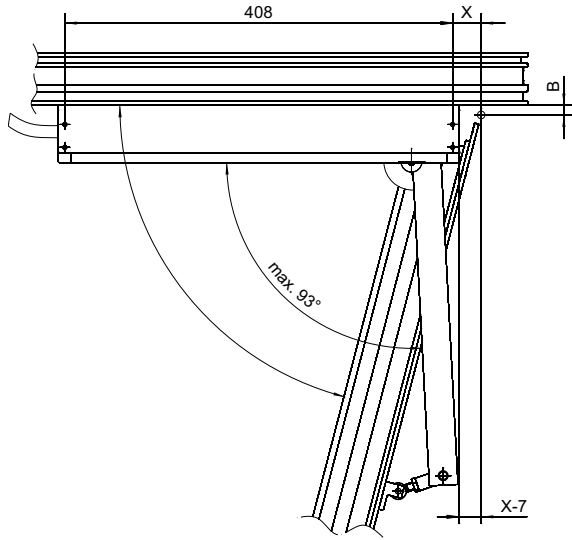

Head point detail

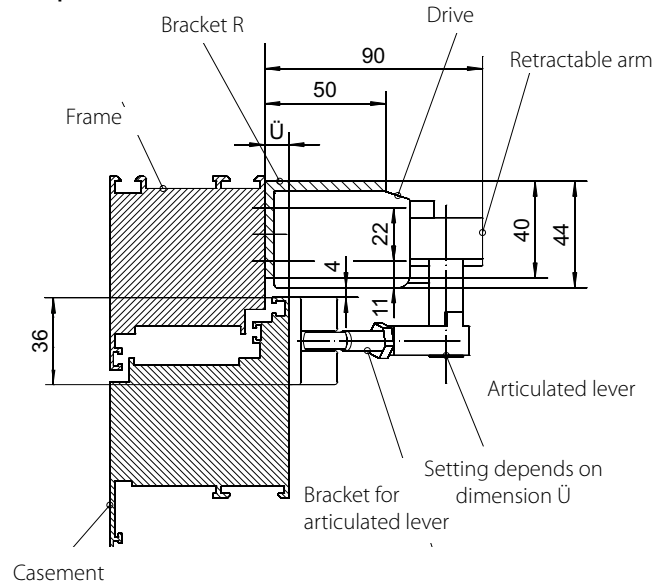

- X = Distance between the window hinge and the drive fixing
- B = Hinge centre spacing
- Ü = Projection of the casement beyond the frame

Installation of bracket R / bracket for articulated lever

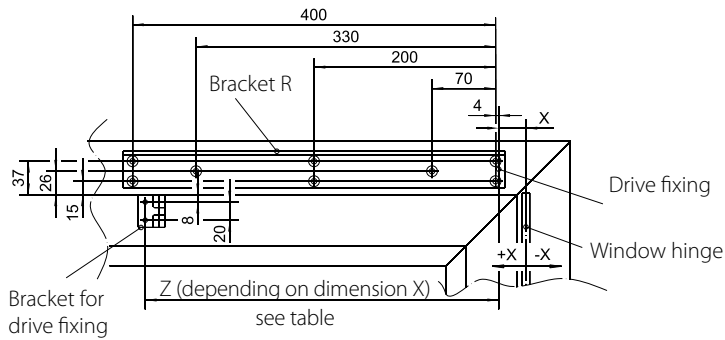

Window opening angle α
 (depending on B and X)

Hinge centre spacing B = 10 ± 2	X	Opening angle α	Z
	-35	84	410
-30	83	410	
-20	82	410	
-15	81	390	
-10	80	390	
0	79	390	
10	77	370	
20	76	370	
30	75	370	

Different opening angles / hinge centre spacings available on request.

Examples

RWA K 600 F hinge side for inward-opening bottom hung and top hung windows

Casement dimensions		Panel weight		Number of drives
NSK	HSK	30 kg/m ²	40 kg/m ²	
800	800	x = -30 mm	x = -30 mm	Solo
		$\alpha = 83^\circ$	$\alpha = 83^\circ$	
800	1200	x = 25 mm	x = 25 mm	Syncro
		$\alpha = 75^\circ$	$\alpha = 75^\circ$	

Ü = 10 mm
 B = 10 mm

GEZE RWA K 600 G retractable arm drive

The RWA K 600 G retractable arm drive can be used both on doors and on windows. In general it can be installed on the hinge side and on the side opposite the hinge. The door cannot be freely passed through due to the fixed connection of the drive with one door leaf by means of a guide rail.

AREA OF APPLICATION

Type of installation	Window, hinge side	side opposite hinge	Door, hinge side	side opposite hinge
Max. leaf weight		30 kg/m ²		250 kg ²⁾
Max. leaf/casement width ¹⁾ HSK	800 mm solo, 1200 mm syncro			1600 mm ²⁾
Min. leaf/casement width HSK		○	470 mm	565 mm
Max. leaf/casement height ²⁾ NSK	2x + 880 mm		○	
Max. leaf/casement height NSK	x + 465 mm		○	
Min. space requirement on the frame		45 mm		45 mm
Min. space requirement on the casement	○	45 mm	○	45 mm

¹⁾ A lock is necessary for larger leaf/casement widths

²⁾ Higher values available on request

Hinge-side installation on the door – fitting dimensions

Plan view

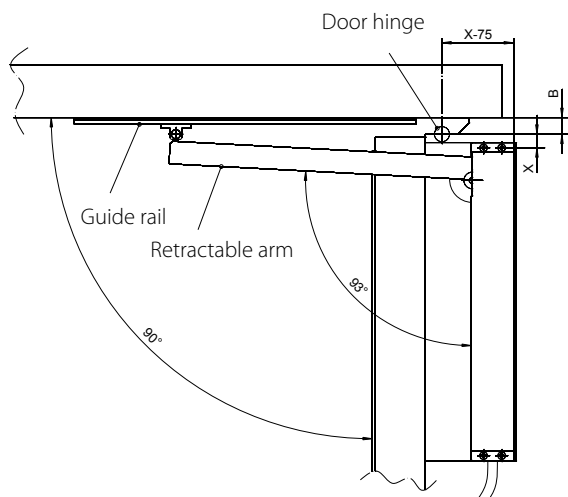

Head point detail

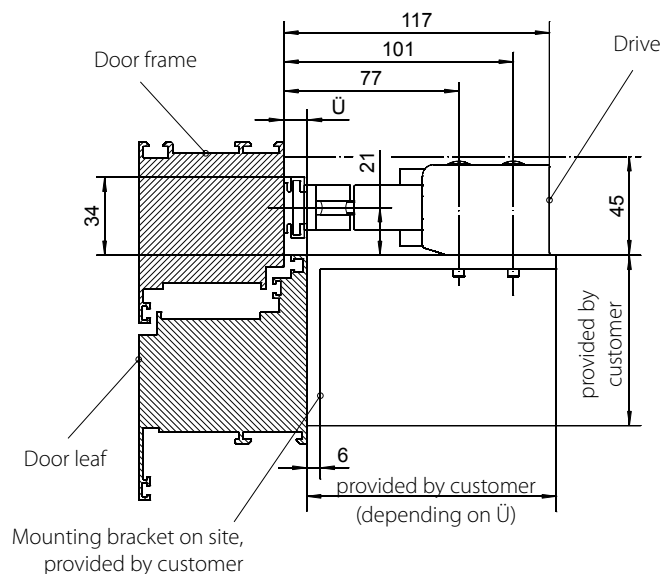

Guide rail installation

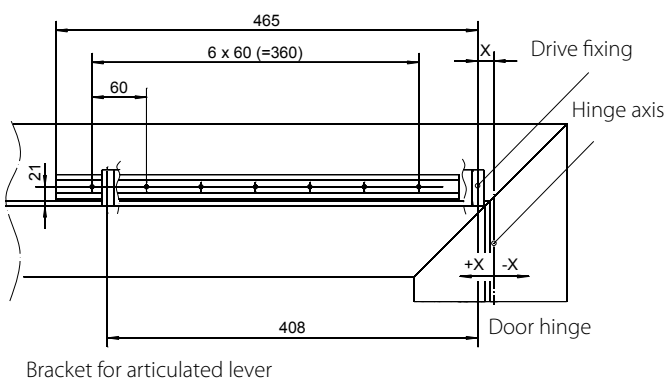

X = Distance of door hinge from the drive fixing

B = Hinge centre spacing

Ü = Projection of the casement beyond the frame (Ü ≤ 20 mm)

Determination of the X dimension with opening angle $\alpha = 90^\circ$:

Examples:

B	X dimension for $\alpha = 90^\circ$
13	30
22	20
36	5

Different opening angles / hinge centre spacings available on request.

Installation on door on side opposite hinge – fitting dimensions

Plan view

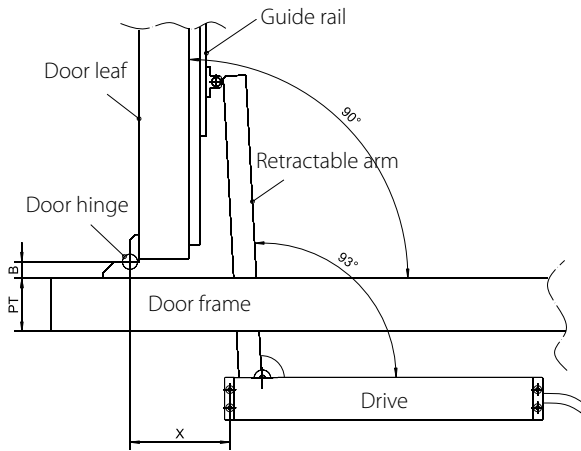

Head point detail

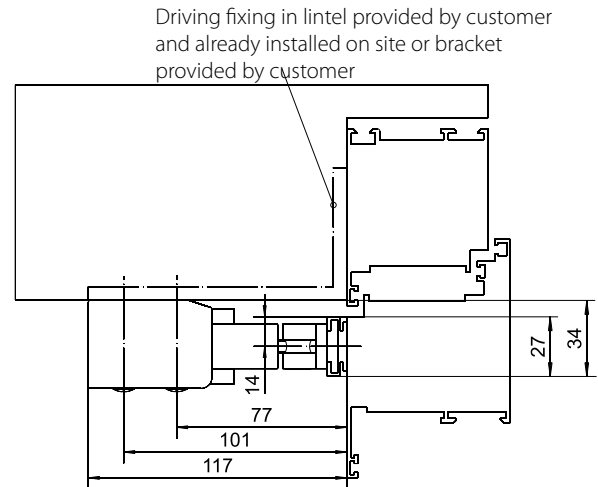

- X = Distance between the door hinge and the drive fixing
- B = Hinge centre spacing
- PT = Profile overall depth, perimeter frame

Guide rail installation

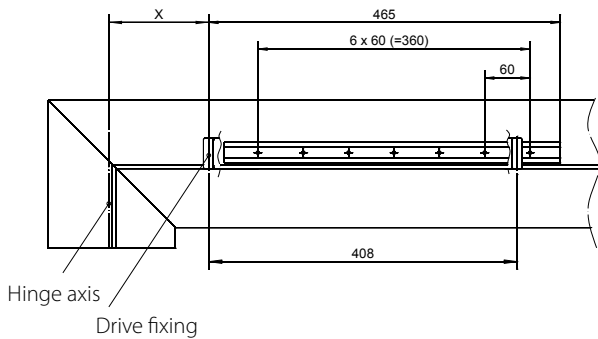

Determination of the X dimension
 with $\alpha = 90^\circ$
 (depending on B and PT)

B	PT	X dimension for $\alpha = 90^\circ$
22	40	100
22	50	110
22	60	120
22	65	125
22	70	130
22	75	135
22	80	140
36	40	115
36	50	125
36	60	135
36	65	140
36	70	145
36	75	150
36	80	155

Different opening angles / hinge centre spacings available on request.

Hinge-side installation on window – fitting dimensions

Plan view

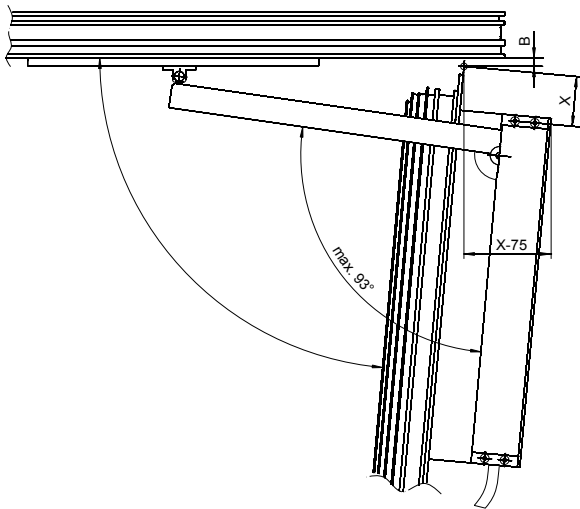

Head point detail

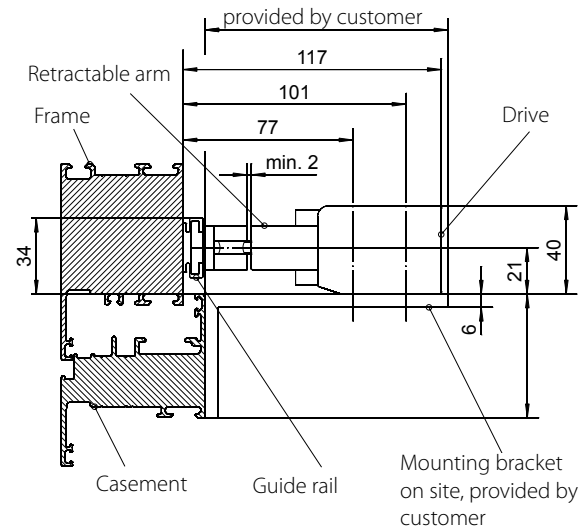

- X = Distance between the window hinge and the drive fixing
- B = Hinge centre spacing
- PT = Profile overall depth, perimeter frame

Guide rail installation

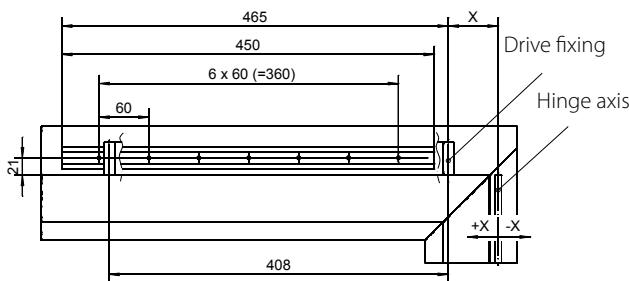

Window opening angle $\alpha = 90^\circ$ (depending on B and X)

X	B	Opening angle α
30	10	90°
60	10	85°
90	10	80°
120	10	75°
150	10	71°
190	10	65°
230	10	60°

Different opening angles / hinge centre spacings
available on request.

Examples

RWA K 600 G hinge side for inward-opening bottom hung and top hung windows

Casement dimensions		Panel weight		Number of drives
NSK	HSK	30 kg/m ²	40 kg/m ²	
800	800	x = 30 mm $\alpha = 90^\circ$	x = 30 mm $\alpha = 90^\circ$	Solo
800	1200	x = 30 mm $\alpha = 90^\circ$	x = 30 mm $\alpha = 90^\circ$	Syncro
1200	1200	x = 160 mm $\alpha = 70^\circ$	x = 160 mm $\alpha = 70^\circ$	Syncro

Installation on window on side opposite hinge – fitting dimensions

Plan view

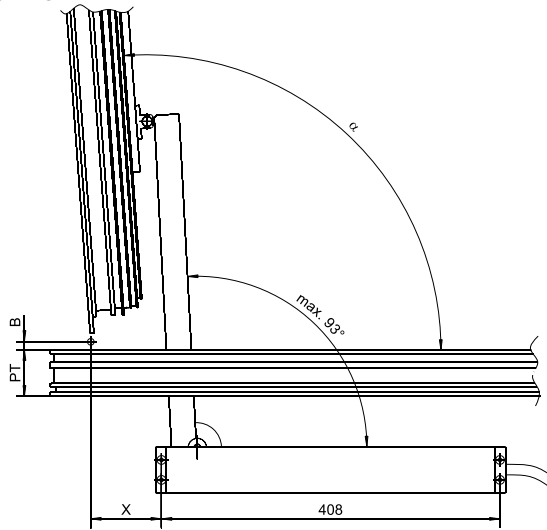

Head point detail

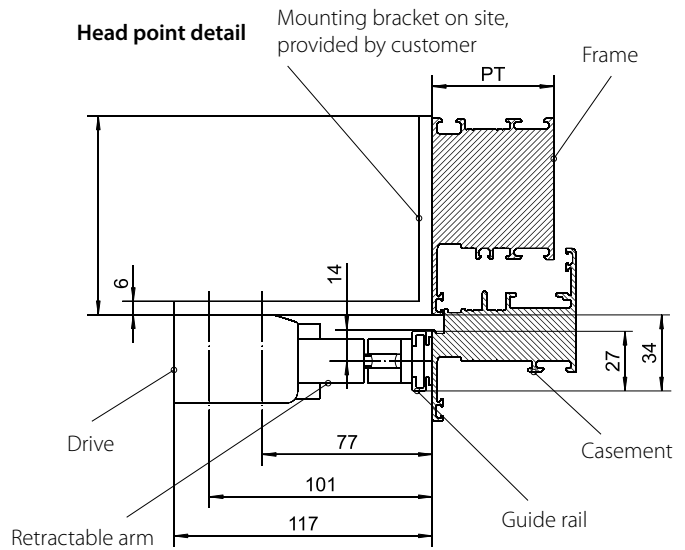

X = Distance between the window hinge and the drive fixing
 PT = Profile overall depth, perimeter frame

Guide rail installation

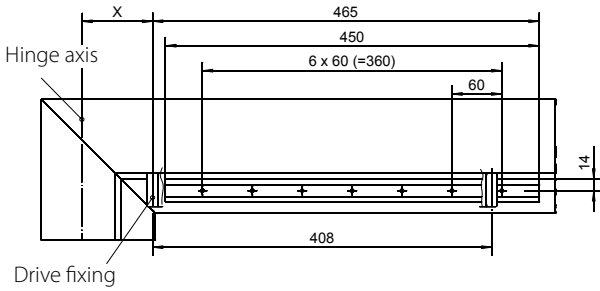

Window opening angle α
 (depending on X, B and PT)

	Hinge centre spacing B ≤ 10 mm		Opening angle α
	X	PT	
	85	65	96°
	95	65	94°
	105	65	92°
	115	65	90°
	125	65	88°
	135	65	85°
	145	65	83°
	85	75	98°
	95	75	96°
	105	75	94°
	115	75	92°
	125	75	90°
	135	75	88°
	145	75	85°

Window opening angle α
 (depending on X, B and PT)

	10 mm ≤ hinge centre spacing B ≤ 22 mm		Opening angle α
	X	PT	
	85	65	99°
	95	65	97°
	105	65	95°
	115	65	93°
	125	65	90°
	135	65	88°
	145	65	86°
	85	75	101°
	95	75	99°
	105	75	97°
	115	75	95°
	125	75	93°
	135	75	90°
	145	75	88°

Examples of RWA K 600 G, side opposite hinge side, for outward-opening bottom hung and top hung windows

Casement dimensions		Panel weight		Number of drives
NSK	HSK	30 kg/m ²	40 kg/m ²	
800	800	x = 115 mm $\alpha = 90^\circ$	x = 115 mm $\alpha = 90^\circ$	Solo
800	1200	x = 115 mm $\alpha = 90^\circ$	x = 115 mm $\alpha = 90^\circ$	Syncro
1200	1200	x = 160 mm $\alpha = 80^\circ$	x = 160 mm $\alpha = 80^\circ$	Syncro

PT = 65 mm
 B = 10 mm

GEZE RWA K 600 T retractable arm drive

The RWA K 600 T retractable arm drive has been designed for use on doors, mounted on the hinge side or the side opposite the hinge. The door remains freely passable due to the freely supported, unrestrained activation of the lever by means of a pressure roll.

AREA OF APPLICATION

Type of installation	Door, hinge side	Door, side opposite hinge
Max. leaf weight	250 kg ¹⁾	250 kg ¹⁾
Max. leaf width	1600 mm ¹⁾	1600 mm ¹⁾
Min. leaf width	470 + x mm	420 + x mm
Brackets	Bracket R and bracket T	○
Min. space requirement on the frame	at the side 145 mm	○
Min. space requirement on the casement	50 mm	40 mm

¹⁾Higher values available on request

Hinge-side installation on the door

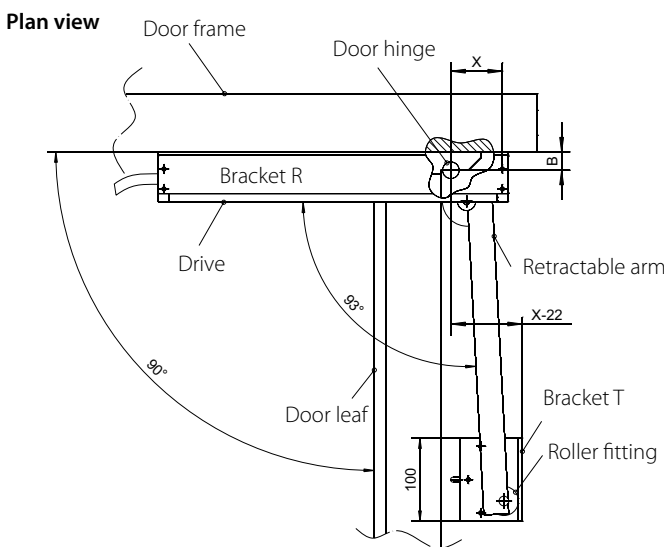

Head point detail

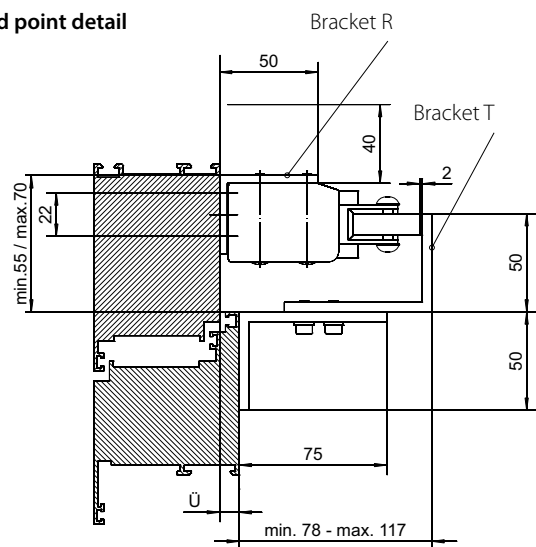

Guide rail installation

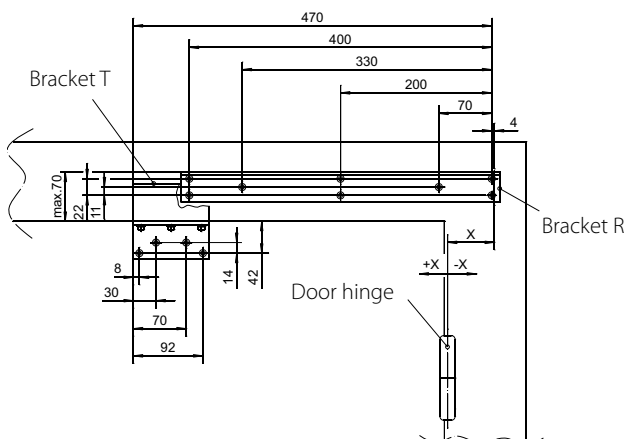

X = Distance of door hinge from the drive fixing

B = Hinge centre spacing

Ü = Projection of the casement beyond the frame

Determination of the X dimension with opening angle $\alpha = 90^\circ$:

Examples:

B	X dimension for $\alpha = 90^\circ$	
	Ü = 0 mm	Ü = 10 mm
13	-60	-70
22	-55	-60
36	-45	-45

Different opening angles / hinge centre spacings available on request.

Installation on door on side opposite hinge – fitting dimensions

Plan view

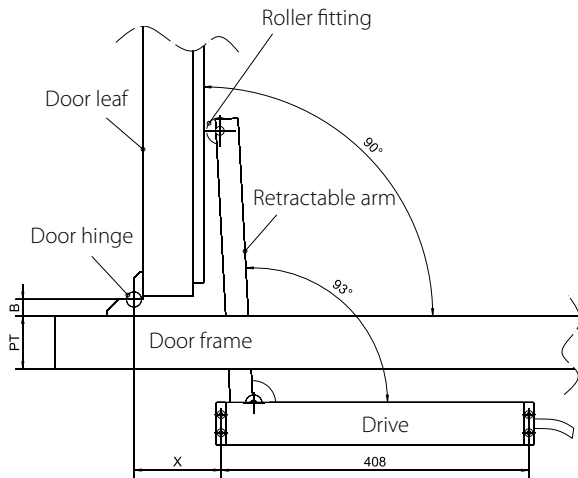

Head point detail

Driving fixing in lintel provided by customer and already installed on site or bracket provided by customer

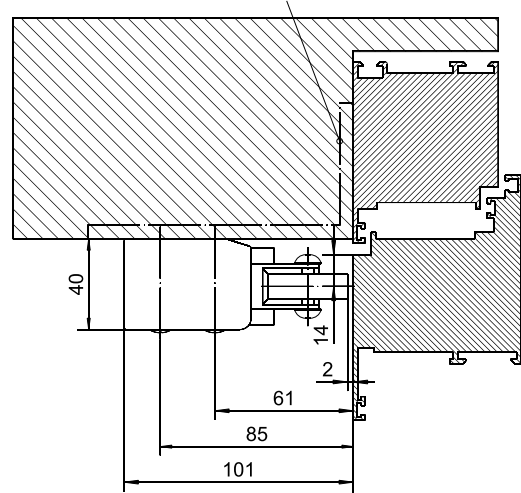

- X = Distance between the window hinge and the drive fixing
- B = Hinge centre spacing
- PT = Profile overall depth, perimeter frame

**Determination of the X dimension
 with $\alpha = 90^\circ$
 (depending on B and PT)**

B	PT	X dimension for $\alpha = 90^\circ$
22	40	80
22	50	90
22	60	100
22	65	105
22	70	110
22	75	115
22	80	120
36	40	95
36	50	105
36	60	115
36	65	120
36	70	125
36	75	130
36	80	135

**Different opening angles / hinge centre spacings
 available on request.**

GEZE RWA AUT fresh air

Automatic opening of the doors in RWA case

This system is used for automatically passable doors which, depending on their location in the building, are used as fresh air or exhaust air openings in the case of an emergency. It provides maximum daily passing convenience. In the RWA case, activated via the emergency power control unit, the door automatically opens in a very short time. A large fresh air inlet surface is produced by the large opening widths of the GEZE automatic doors. By combination with automatic door systems, the RWA AUT door can also be passed through with maximum convenience in daily use as well as being used as an emergency exit door. Securing the automatic door in accordance with DIN 18650 ensures convenience and safety.

GEZE RWA AUT



System arrangement

The system explained in the following is given as an example. Please contact GEZE for details of the options of other versions and variations.

In the lock area

- ① Emergency exit opener type 331
- ② Latch lock type 807-10

On the door lintel

- ③ TSA 160 NT Invers swing door drive
The system can also be used for double-leaf doors.

Next to the door

- ④ Elbow switch for opening the door in normal operation
Other types of activation, e.g. radar, are also possible.
- ⑤ Emergency stop button (door opens without current)

In the building

- ⑥ Emergency power supply units
- ⑦ Emergency power supply UPS 700 or 1000
(required if the must not open in the event of a power failure)
- ⑧ Main switch

In the stairway

- ⑨ RWA pushbutton FT4
- ⑩ One or several smoke and/or heat detectors (mounted on ceiling)
for automatic activation
- ⑪ Power supply

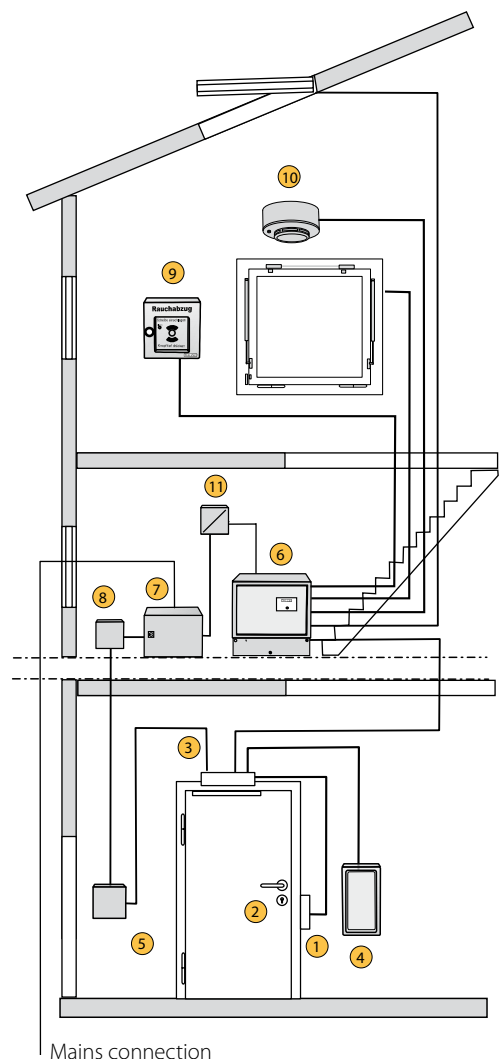

GEZE RWA AUT fresh air - functional description

Function description with FTÖ 331

Compared to swing door drive TSA 160 NT, which opens the door automatically and closes by spring force, the TSA 160 NT Invers drive inverts this function. In this case the closing action is automated, the opening takes place mechanically by means of spring force (advantage in RWA case). I.e. the TSA 160 NT Invers opens by means of spring force in case of fire or in the event of a power failure – closed-circuit principle. It is therefore also necessary to use no-load door openers (or retention magnets); electric strike fail secure openers would not release the door in the event of a power failure. An uninterruptible power supply (UPS) is required to prevent unwanted opening of the door in the event of a power failure (e.g. at night).

Opening the door in case of emergency

In the event of a fire button or smoke detector alarm the power supply to the drive and to the door opener is interrupted. The doors are immediately unlocked and mechanically opened to ensure reliable smoke removal. The doors remain open until the alarm is reset.

Opening the door in normal operation

The door opener is unlocked by pressing an elbow switch or other pulse generator. The spring-tensioned swing door drive opens the door mechanically by means of spring force.

Closing the door in normal operation

In normal operation the door automatically closes via the control of the swing door drive after the set hold open time has expired.

Supply to the shut-down indicator board

The shut-down indicator board of the TSA 160 NT Invers must be supplied with an additional power supply.

Manual passing through the door

A door equipped with the TSA 160 NT Invers cannot be simply passed through manually. The door kept closed, not only by the emergency exit opener but also by the solenoid valve of the hydraulics. As manual passing through the door does not generate an activation signal, when the door is manually opened the drive attempts to close it again – this is comparable to the permanently open position of the (standard) TSA 160 NT, from which it cannot be closed manually.

Emergency power supply UPS

If the door must not open in the event of a power failure, the Invers must also be equipped with a UPS in addition to the additional power supply required.

Note: Version with automatic swing door drive in accordance with DIN 18650.

Combination of TSA 160 NT Invers with motor lock IQ Lock EL

The TSA 160 NT Invers can be combined with the GEZE motor lock. As the lock operates according to the open-circuit principle, in the RWA case it is necessary to ensure that the lock is supplied with 24 V, e.g. by a GEZE RWA control unit E 260 N... Use of the GEZE motor lock IQ Lock EL is only possible on 1 leaf doors. The MST 212 circuit board is also required for the RWA fresh air function; in the RWA case the board forwards the activation of the RWA control unit to the lock and simultaneously switches off the TSA 160 NT Invers.

Opening the door in case of emergency:

The additional MST 212 circuit board is activated, e.g. by the E 260 N. On the one hand, the MST 212 supplies the motor lock with voltage, on the other hand it activates the lock, which means the lock is reliably unlocked, i.e. even in the event of a power failure. The power supply at the TSA160 NT Invers drive is interrupted by a contact in the MST 212. As soon as the lock has been unlocked the doors are opened by the spring force of the drive.

Closing the door after an alarm:

After cancelling the alarm, activated RWA pushbuttons and / or the smoke and heat differential detectors must be reset. If the door is closed, it is automatically locked again via the motor lock or switches to the operating mode set at the lock. The door is therefore locked again. After the alarm, the lock locks in precisely the same operating setting as the one set before the alarm (night / day / continuously open). The TSA 160 NT Inver must be reset.

Opening the door in normal operation:

The GEZE IQ Lock EL is unlocked by pressing an elbow switch or other pulse generator. The spring-tensioned swing door drive opens the door mechanically by means of spring force.

Closing the door in normal operation:

In normal operation the door automatically closes via the control of the swing door drive after the set hold open time has expired. The shut-down indicator board is supplied via the power supply of the MST 212.

Manual passing through the door

Manual passing through the door is possible by pressing the internal door handle or by means of a key and a cylinder lock.

GEZE fresh air RWA AUT with swing door drive TSA 160 NT Invers and RWS

System arrangement

Additional components for RWS control:

- TZ 220 door control unit
- KL 220 terminal box
- Additional opener (break) contact for emergency button

Description of function

- The shut-down indicator board of the TSA 160 NT Invers is supplied with voltage from the door control unit and in case of an emergency is disconnected from the power supply so that the door reliably opens. At the same time the fire alarm system or alarm contact of the emergency power supply control unit is connected to the door control unit. A separate power supply for supplying the shut-down indicator board is not required.
- To prevent unwanted opening of the door in the event of a power failure and to secure them through the door control unit, TSA 160 Invers and door control units must be buffered by means of an uninterruptible power supply.

Opening the door in case of emergency

If the emergency button of the door control unit is pressed and in the event of an alarm of a fire button or smoke detector, the TSA 160 NT Invers is disconnected from the power supply via the door control unit and at the same time the emergency door opener is unlocked. The door is immediately opened mechanically and remains open until the alarm is reset.

Closing the door after an alarm:

After cancelling an alarm, activated RWA pushbuttons and / or the smoke and heat differential detectors and any activated emergency buttons of the door control units must be reset. In addition, the alarm must be acknowledged at the door control unit by means of a key-operated switch.

Passing through door if RWS is locked – secured operation

By actuating the key-operated switch of the door control unit or other release elements (card reader, ext. key-operated switch) the door opens automatically and automatically closes and locks after the short-term unlocking has expired (max. five minutes). The release elements of the TSA 160 NT Invers are not active here. If the short-term unlocking is exceeded, a pre-alarm is started, which switches to a door alarm after three minutes, this must be subsequently acknowledged at the door control unit using a key.

Passing through the door if RWS unlocked – unsecured operation

By activating the release elements (elbow switch, radar detector), the TSA 160 NT Invers the door automatically opens by means of spring force and closes after the hold open time set at the swing door drive has expired. For security reasons, security sensors are also recommended here to secure the swivel range.

Technical data

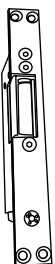

Emergency exit opener 331

unlocks the door according to the closed-circuit principle

Operating voltage	24 V DC
Power consumption	160 mA
Compressive strength	7500 N



Latch lock

Counterpart to the emergency exit opener

Technical data

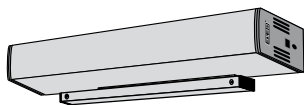

TSA 160 NT Invers swing door drive

Opening by means of spring mechanism and adjustable hydraulic valves	
Closing by means of hydraulic pump system	
Variations for single and double-leaf doors	
External dimensions of the drive	690 x 100 x 120 mm
Casement widths	max. 1400 mm
Casement weights	max. 250 kg
Output voltage	24 V DC
Operating voltage	230 V AC
Power consumption	300 W

Note: For further details, please refer to the product documents of the GEZE TSA 160 NT.

Power supply for uninterruptible emergency power supply

USV 700 (e.g. for 1 leaf automatic swing door drive)	100 VA
USV 1000 (e.g. for two 1 leaf doors or one 2 leaf swing door drive)	1000 VA
Power supply 24 V	

GEZE RWA-EM "OPEN" – ELECTROMAGNETIC

GEZE RWA EM "OPEN" – electromagnetic

For inward-opening vertically installed bottom hung, top hung, horizontally pivot hung and side hung windows

- Casement width of 300 mm to 1000 mm (top hung casement) or 1200 mm (bottom hung casement) with magnetic primary lock
- Casement width up to 2000 mm (top hung casement) or 2400 mm (bottom hung casement) with magnetic primary lock, connecting rod and secondary lock

GEZE RWA EM



System arrangement

- 1 Magnetic primary lock E8/a for 24 V DC with casement bracket for wooden and metal windows
- 2 Mechanical secondary lock C8/b, with casement bracket for non-flush-closing and flush-closing windows, for wide casements
- 3 Connecting rod for mechanical connection from the primary to the secondary lock
- 4 Spring arm, with frame and casement bracket, with opening damping
Spring pressure and spring stroke and spring force are matched to the window system
- 5 Smoke and heat switch (ceiling mounted), type 142 with base for automatic activation
- 6 Pushbutton E45 "Open with light", with viewing panel, lockable
Arrangement on the ground floor and on upper storey, additionally in other positions
- 7 Mains rectifier E 8g/24 V DC
Capacity according to the number of magnetic locks and smoke switches
- 8 Emergency power supply E 250/24 V DC with integrated rechargeable battery for bridging short-term power failures

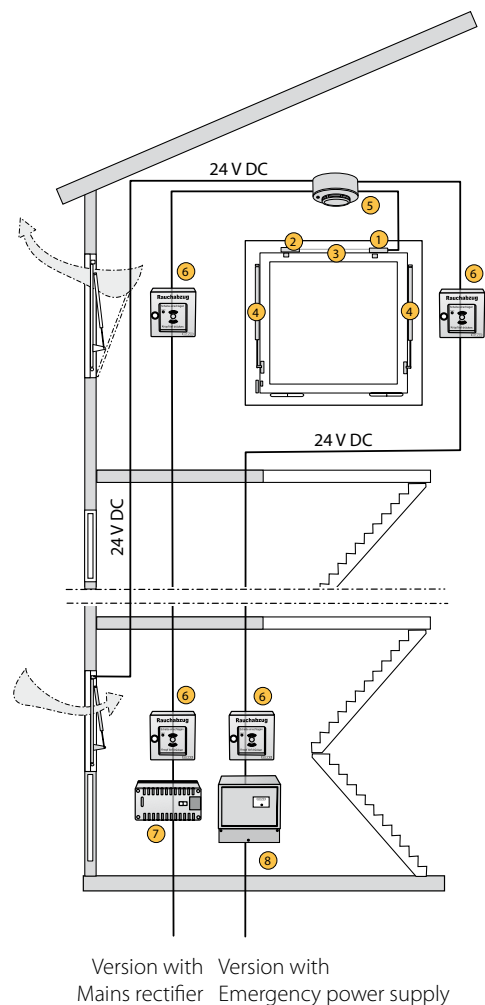

GEZE RWA-EM "OPEN" – ELECTROMAGNETIC

GEZE RWA EM fresh air - description of function

Description of function

The magnetic primary lock and mechanical secondary lock keep the window casement securely closed against the pressure of the spring arms and the pressure of the wind.

The magnet in the primary lock is continuously supplied with current and keeps the bolt in the closed position against a compression spring (closed-circuit principle).

Opening the window by interrupting the closed-circuit current

▪ **Manual:**

By pressing the pushbutton or other devices for interrupting the current

▪ **Automatic:**

By pressing the smoke and heat switches and in the event of a mains power failure (only in version with mains rectifier)

Manual closing of the window

The closed-circuit current flow must be reinstated by resetting the buttons or smoke and heat detectors. Closing the door by hand against the pressure of the spring arms and pushing on the magnet in the magnetic primary lock.

Using an emergency power supply prevents unwanted opening of the windows in the event of short power failures, by then automatically switching to battery mode.

This RWA system is not recommended for windows which can only be closed by climbing a ladder or scaffolding. It must be possible to manually close the system – this must also be taken into account for the half-yearly functional test.

Technical data

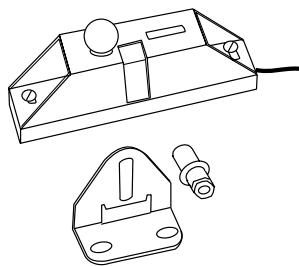

Electromagnetic lock	
pre-assembled units	
Housing and baseplate buffer made from anodised lightweight metal EV1	
Power consumption per primary lock 0.13 A	
in side hung casements: Casement height min. 1.5 x casement width	

Secondary lock	
mechanical	
can be coupled to primary lock with connecting rod	

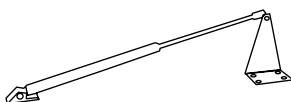

Spring arm	
safe, reliable, space-saving and dirt-protected unit	
preassembled unit (EV1)	
with backcheck	
up to max. 30 kg/m2 panel weight	
Stroke 150 – 300 mm	
Pressure force 150 – 250 N	
Opening angle up to 70° depending on the stroke and casement height	

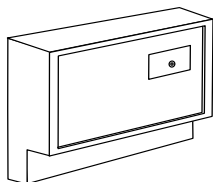

E 250 N emergency power supply 24 V AC/1.2 A	
For technical data, see GEZE RWA TÖ system	

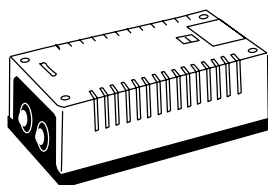

Mains rectifier	E8g/24 V DC	NAG03/24 V DC
Input voltage	230 V AC	230 V AC
Output voltage	24 V DC	„4 V DC
Mains current	0.4 A	0.9 A
Protection type	IP 20	IP 30
Number of connectable MV	max. 2 MV with smoke switch	max. 5 MV without smoke switch max. 7 MV without smoke switch
Plastic housing	light grey	white

GEZE RWA CO₂ "OPEN"

For inward-opening vertically installed bottom hung, top hung and horizontally pivot hung windows

- Casement width up to 1000 mm (bottom hung casement) or 1200 (top hung casement) with CO₂ primary lock
- Casement width up to 2000 mm (bottom hung casement) or 2400 (top hung casement) with CO₂ primary lock, connecting rod and secondary lock

System arrangement

- 1 CO₂ primary lock for compressed gas or compressed air, with two casement brackets, for wooden and metal casements
- 2 Mechanical secondary lock with two casement brackets, for wooden and metal casements
- 3 Connecting rod for mechanical connection from the primary to the secondary lock
- 4 Spring arm, with frame and casement bracket, with opening damping
Spring force and spring stroke are matched to the window system
- 5 Alarm box with integrated impact valve, for manual activation
a) without visual display
b) with visual display
- 6 Copper pipe 6 x 1 mm
- 7 T-fitting for copper pipe 6 x 1 mm

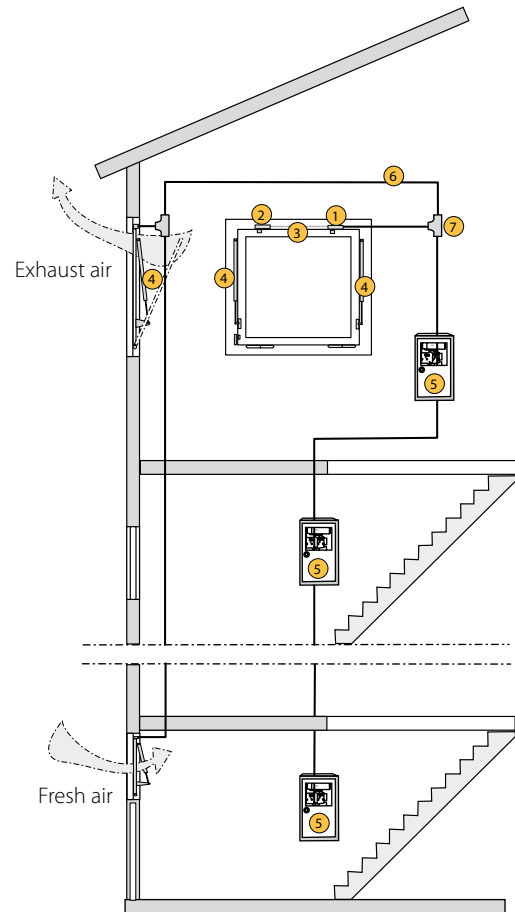

GEZE RWA CO₂ "OPEN" – description of function

Description of function

The CO₂ primary lock and mechanical secondary lock keep the window casement securely closed against the pressure of the spring arms and the pressure of the wind. The bolt in the primary lock is subjected to spring pressure. The primary lock has a pressure cylinder which is connected to the release stations via a copper cable. The release station (alarm box) is equipped with CO₂ cartridges. These CO₂ cartridges provide the energy for releasing the windows, independently of other energy sources. The size of the CO₂ cartridges must be specified depending on the number of pressure cylinders and the length of the line.

Opening the window

On actuating a release station, the CO₂- cartridge is punctured. The CO₂ gas flows through the copper pipe to the pressure cylinders in the primary locks. The pressure cylinders release the bolt in the windows. The tensioned spring arms open the windows.

Manual closing of the window

The casements are pressed back manually against the pressing force of the spring arms. The bolts automatically latch into the locks. After closing the punctured CO₂ cartridges in the release station must be replaced. Alarm boxes, from whose position the windows to be opened are seen do not have to have a visual display. This RWA system is not recommended for windows which can positioned high and can only be closed by climbing ladders or scaffolding, e.g. after each half-yearly function test.

GEZE RWA CO₂ "OPEN"

Technical data

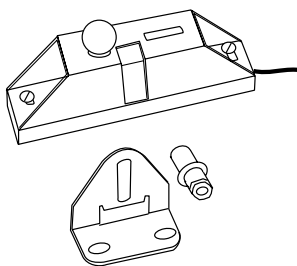

CO₂ primary lock

pre-assembled units
 Housing and baseplate buffer made from anodised lightweight metal EV1
 with connecting rod and secondary lock
 Connection to copper pipe 6 x 1 mm

Secondary lock

mechanical

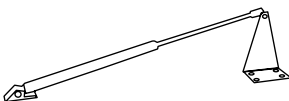

Spring arm

safe, reliable, space-saving and dirt-protected unit
 preassembled unit (EV1)
 with backcheck
 up to max. 30 kg/m² panel weight
 Stroke 150 – 300 mm
 Pressure force 150 – 250 N
 Opening angle up to 70° depending on the stroke and casement height

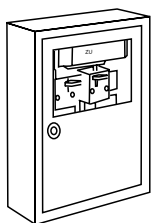

Alarm box

Inspection window made of glass (2 mm) in the door
 Door lockable
 CO₂ cartridges 18 g
 Push in inspection window in case of emergency
 max. 10 primary locks and 70 mm copper pipe 6 x 1 mm
 Surface-mounted and flush-mounted version

Accessories for GEZE RWA systems

Safety scissor stays

Area of application: For securing and limiting the bottom hung casement



GEZE safety scissor stay No. 35

GEZE safety scissor stay No. 35

If installed on bottom hung casements, for product liability reasons, installation of separate safety scissor stays is specified. These additional safety devices ensure permanent connection between the casement and frame, e.g. GEZE safety scissor stay No. 3.

Description	Id. No.
GEZE safety scissor stay No. 35	014499

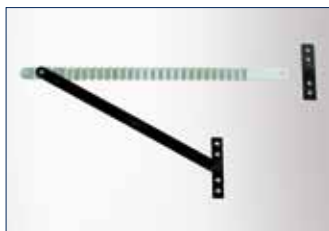

GEZE safety scissor stay No. 60

GEZE safety scissor stay No. 60

Safety scissor stay as protection against falling, vertically installed bottom hung windows made from aluminium, PVC or wood.

Note:

- Two scissor stays must always be installed!
- The relevant baseplates must be used to ensure secure fixing.
- For details of the permissible casement weights (max. 250 kg) and fitting dimensions, please refer to installation instructions No. 134433 and installation drawing 41314-EP-001

Description	Id. No.
GEZE safety scissor stay No. 60	133814



GEZE gripping and cleaning scissor stay (FPS)

GEZE gripping and cleaning scissor stay (FPS)

For bottom-hung casements, safeguards must be provided in addition to the fanlight opener, which limit the tilting movement of the casement (grip position), so that the casements do not become a source of danger. GEZE FPS is the «intelligent» gripping and cleaning scissor stay for vertically installed bottom-hung rectangular windows.

Description	Id. No.
GEZE gripping and cleaning scissor stay (FPS) FPS 340 mm Größe 1	030249
GEZE gripping and cleaning scissor stay (FPS) FPS 520 mm Größe 2	030250
GEZE gripping and cleaning scissor stay (FPS) FPS 720 mm Größe 3	030251

Control elements

Area of application: Manual alarm actuation



RWA button FT4

GEZE RWA button FT4/24 V DC-VdS

The RWA button FT4 with pushbutton locking are intended for manual alarm actuation in case of fire. The surface-mounted housing is made from stable die-cast aluminium with a replaceable glass pane according to DIN 14655. Due to its considerably higher protection against vandalism, the housing offers clear quality advantages and is therefore particularly recommended for public buildings and facilities.

- Clearly traceable, identifiable release by engagement of the pushbutton
- Switching capacity max. 100 mA 24 V DC
- Reset button for resetting the alarm
- With LED operating state displays
- Flush mounting

Recommended installation

- Distance between pushbutton and floor 1.4 ±20 cm
- Clearly visible in stairway or corridor
- The RWA button must not be concealed by door leaves

Description	Version	Id. No.
RWA button FT4 VdS certified	Orange RAL 2011	099561
	Red RAL 3001	106380
RWA button FT4	Grey RAL 7035	106382
	Blue RAL 5015	106381
	Yellow RAL 1021	106885



RWA button FT4, plastic housing

Description	Version	ID. No.
RWA button FT4 plastic housing, 24 V DC	Orange similar to RAL 2011	136232
	Red similar to RAL 3000	136233
RWA button FT4	Grey similar to RAL 7035	136235
	Blue similar to RAL 5009	136234
	Yellow similar to RAL 1018	136236

Accessories for GEZE RWA systems



Synchronised cut-off E 102

GEZE synchronised cut-off E 102

The synchronised cut-off is used for joint shutdown of two electrically operated spindle drives 24 V DC, which are mounted on one window element. An adjustable time delay ensures that runtime differences between the two drives are levelled out in the end position and uniform contact pressure of the casement.

- Supply voltage 24 V DC, min. 16 V DC, max. 40 V DC, residual ripple max. 25%
- Connectable motors two 24 V DC drives with integrated load cut-off
- Motor current per motor max. 2.2 A
- Time delay can be set between 0 to 10 sec., default setting approx. 0 sec.
- Opening time limit can be set between 5 and 60 sec., default setting approx. 5 sec.
- Connection cross-section max. 2.5 m²
- Enclosure rating IP 54
- Dimensions (H x B x D) 113 x 113 x 58 mm

Description	Id. No.
Synchronised cut-off E 102	101323

Control elements

Area of application: Automatic alarm actuation



Smoke detector RM 1003

GEZE smoke detector RM 1003/24 V DC-VdS

The automatic smoke detector type 1003 with VdS approval operates according to the principle of optical scattered light and is used for automatic release of the RWA in case of fire. With VdS approval. Dimensions: 42 mm x ø 102 mm, weight 120 g

- Air velocity in accordance with EN 54 Part 7
- Operating voltage 8 V to 30 V
- Individual display with red LED
- Operating ambient temperature -20 °C to +60 °C

Note:

Smoke detectors should not be used if operating interference such as dust, smoke or vapour is to be expected.

Description	Id. No.
RM 1003 smoke detector, VdS certified	112877



Heat differential detector WM 1005

GEZE heat differential detector WM 1005/24 V DC-VdS

The heat differential detector type 1005 with VdS approval operates according to the functional principle of the semi-conductor temperature sensor. The response variables are temperature rise and temperature limit value of the ambient temperature. With VdS approval. Dimensions: 42 mm x ø 102 mm, weight 120 g

- Operating voltage 8 V to 30 V
- Individual display with red LED
- Operating ambient temperature -20 °C to +60 °C

Note:

Heat differential detectors should not be used if rapid temperature fluctuations are to be expected due to operating conditions.

Description	Id. No.
WM 1005 heat differential detector, VdS certified	112878

Accessories for GEZE RWA systems



Synchronising unit 24 V

GEZE synchronising unit 24 V

This synchronising unit is suitable for all GEZE electric drives with 24 V.

Description	Id. No.
Synchronising unit 24 V	111198

Venting mode

Area of application: Electrical RWA with additional venting function



Vent switch LTA-24

GEZE AS 500 vent switch LTA-24

- 24 V mains voltage
- Triple switch
- With "Open-Stop-Closed" function keys
- With LEDs to display "Open-Closed"
- Flush mounting

Description	Id. No.
AS 500 vent switch LTA-24	118473



Vent switch LTA-24-SCT

GEZE AS 500 vent switch LTA-24-SCT

- 24 V mains voltage
- Triple switch
- With "Open-Stop-Closed" function keys
- With LEDs to display "Open-Closed"
- Combined with key-operated switch
- Double frame
- Flush mounting

Description	Id. No.
AS 500 vent switch LTA-24-SCT	127176



Vent switch LTA-230

GEZE AS 500 vent switch LTA-230

- 230 V
- Triple switch
- With "Open-Stop-Closed" function keys
- Flush mounting

Description	Id. No.
AS 500 vent switch LTA-230	118474



Vent switch LTA-230-SCT

GEZE AS 500 vent switch LTA-230-SCT

- 230 V
- Triple switch
- With "Open-Stop-Closed" function keys
- Combined with key-operated switch
- Double frame
- Flush mounting

Description	Id. No.
AS 500 vent switch LTA-230-SCT	118475

Accessories for GEZE RWA systems

Venting mode

Area of application: Electrical RWA with additional venting function

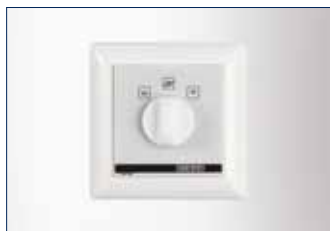

Vent switch LTA-LSA

GEZE AS 500 vent switch LTA-LSA

- 230 V
- Triple switch
- With "Open-Closed" function keys
- With optional switch or latching function
- Flush mounting

Description	Id. No.
AS 500 vent switch LTA-LSA	118476



Vent switch LTA-24-AZ

GEZE AS 500 vent switch LTA24-AZ

- 24 V mains voltage
- Double switch
- With "Open-Closed" function keys
- Flush mounting

Description	Id. No.
GEZE AS 500 vent switch LTA24-AZ	129393



Key-operated switch SCT

GEZE key-operated switch SCT

- For flush mounting
- Supplied without profile cylinder

Description	Id. No.
Key-operated switch SCT single pin	117996
Key-operated switch SCT two pin	118478



Information labels

GEZE information labels

- Dimensions (H x B) 52 x 148 mm

Description	Id. No.
Ventilation information label	025647
Smoke extraction information label	005158



Signal horn

GEZE signal horn

- Signal horn 24 V DC

Description	Id. No.
Signal horn for generation of acoustic signal	072112

Accessories for GEZE RWA systems



Control unit with evaluation electronics, weather station



Visual display unit

GEZE rain-wind control

The rain-wind control unit can be connected to several control units without an additional relay (loop through signal). A rain-wind control unit provided on site by the customer can also be used; this requires a potential-free make contact provided on site by the customer.

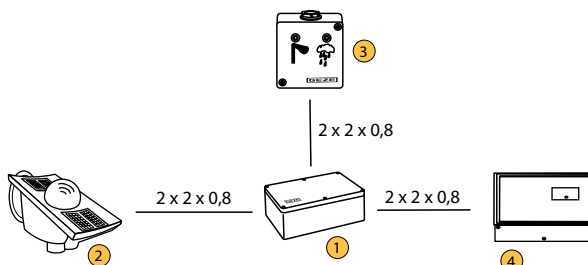

Components

- ① Control unit with evaluation electronics
- ② Weather station
- ③ Visual display unit
- ④ Transfer to the emergency power control unit with potential-free switch contact

Control unit with evaluation electronics

The control includes the power supply and the potential-free switching contacts with microcontroller control of the rain-wind signals. The evaluation takes place individually or jointly. The weather station is supplied with 24 V DC/GND/signal input.

Weather station

The weather station unit contains the rain, wind and temperature sensors. The wind is measured electrically by means of a heated ceramic wire; this removes the need for the usual mechanical measurement using wind scoops. The rain is measured by the gold-plated printed conductors on the surface, which measures even the finest rain.

If the rain-wind control is released, the connected vent switches are disabled and all the connected drives are activated to "CLOSED". But an alarm has precedence over the rain-wind control, i.e. in the event of an emergency, the windows will be opened even if the rain-wind control is active (the windows are not closed). The switching point of the wind speed sensor can be set between 1-15 m/s.

Description	Id. No.
Rain-wind control (weather station plus evaluation electronics)	091529
Visual display for optical signals in case of rain and wind activity	029238



Room temperature regulator E 70

GEZE room temperature regulator E 70

The E 70 room temperature regulator is used for control in interior rooms. The temperature switching point can be individually set between 5 °C and 30 °C.

Description	Id. No.
Room temperature regulator E 70	079087

Timer

If a timer is connected, windows are opened or closed at preselectable times. Optionally, a timer can be connected to each vent switch line, whereby these must be set to pulse signal, not continuous signal. The timer and vent switches are equal ranked control elements, i.e. the RWA emergency power control unit takes into account the last signal.

Accessories for GEZE RWA systems

GEZE radio programme

With a new and innovative radio solution, GEZE has adapted their range of control elements. The wireless control of doors and windows using the GEZE radio programme makes connection to a power supply superfluous. Thanks to the tiny dimensions of the radio modules, they can easily be integrated in the drive or an in-wall casing and can also be clipped directly into the elbow switch and mounted wirelessly on glass.



GEZE hand-held radio transmitter, 1 channel



GEZE hand-held radio transmitter, 2 channel



GEZE hand-held radio transmitter, 4 channel



GEZE WTM radio transmitter module

Examples of types of application

- Retro-fitting without needing to lay cables and using existing switches/buttons
- Mounting without connection to power, for example, on glass
- Individual or group control of windows and doors
- Combined activation of doors and windows using a remote control

GEZE radio transmitter

For wireless activation of doors and windows, as multi-channel solution. For each additional channel, another terminal can be switched by pressing a button.

GEZE radio receiver

- Simple teach-in of the receiver with acoustic feedback
- Up to 85 radio receivers can be taught-in
- DIP switches for selecting operating mode of the radio receivers (pulse mode, pulse and continuous operation)
- 2 Relay outputs for individual connection options

Description	Version	Id. No.
Hand-held radio transmitter	WTH-1	131209
	WTH-2	131210
	WTH-4	131211
Spare battery for hand-held radio transmitter		131217
Radio transmitter module	WTM	131212
Spare battery for radio transmitter module		131218
Elbow switch KFT	white, surface-mounted	114078
	niro, surface-mounted	114077
Backplate for elbow switch KFT	white	131219
	niro	131220
Elbow switch LS990	Surface-mounted	128582
	Concealed	128583
Fan switch LTA24-AZ	Concealed	129393
Radio receiver module	WRM-24	131213
	WRM-230	131215
Radio receiver module in the IP-54 housing	WRM-24B	131214
	WRM-230B	131216
Radio receiver board	WRB-5	135170

LEGAL BASIS OF RWA

Legal basis of RWA *)

Planning & building law

The objectives of the planning & building law are as follows:

- Prevent the occurrence of a fire
- Stem spreading of the fire
- Secure escape routes
- Make fire fighting possible
- Contain environmental pollution in the form of the emission of contaminants, water pollution

*) Please note: The explanations refer to Germany; country-specific differences must be noted and complied with abroad.

Planning & building law in Germany is divided into building law and construction products law. These are explained in greater detail in the following:

BUILDING LAW

Building law

In the building law, structural fire protection is specified centrally. As building law is part of the legislation of the German federal states, there are separate state building regulations for each individual federal state. The same also applies to the special building codes. All regulations for the building or special building are specified here. The respective regulations give information for the dimensioning of smoke dissipaters and extractors. The following is an overview of the contents of these regulations:

MBO (Model building regulations):

The model building regulations (MBO), jointly drawn up by all the states, is the basis of the state building regulations. They define the fire safety protection goals, because buildings must conform to the general statutory requirements.

MBO § 3, Para. 1 (Version November 2002)

“Facilities shall be arranged, built, modified and maintained so that public safety and order, especially life, health or natural habitats and livelihoods are not endangered.”

MBO § 14 (Version November 2002)

“Building systems are to be arranged, built, modified and maintained in such a way that the occurrence of a fire and the spreading of fire and smoke (fire spreading) is prevented and the rescue of people and animals and, in the event of a fire, effective fire fighting is possible.”

The general requirements of the MBO are adopted by the state building regulations accordingly and are defined in specific terms in the wording of the law of the respective building regulations and their supplementary provisions for special buildings by additional requirements. The special building codes of the federal states are also based on model regulations. In addition, public-law and private guidelines also apply.

For this reason, the following tables can only give an overview and it is necessary to also note and follow the regulations of the respective federal state in which a building or structure is to be built.

MBO § 39, Para. 8 (Version November 2002)

“Necessary stairwells must be able to be ventilated. On each above-ground storey, they must have windows leading directly to the outside with a free cross-sectional area of at least 0.50m², which can be opened. For necessary internal stairways and necessary stairways in buildings more than 13 m high (according to §2 Para. 3 Sentence 3), an opening for smoke dissipation with a free cross-sectional area of at least 1m² is required at the highest point; they must be able to be opened from the ground floor and from the top landing.”

MBO § 37, Para. 4 (Version November 2002)

“Each basement storey without windows must have at least one opening to the outside to enable smoke dissipation. Joint basement lightwells for basement storeys above each other are not permitted.”

MBO § 39, Para. 3 (Version November 2002)

“It must be possible to ventilate lift shafts and they must have an opening for smoke dissipation with a free cross-sectional area of at least 2.5 % of the floor area of the lift shaft; however, at least 0.10m². The location of the smoke outlet openings must be chosen so that the smoke is not impaired by wind.”

MBO § 51 (Version November 2002)

Special requirements can be set for special buildings on a case by case basis to implement the general requirements according to § 3 Para. 1. (...)

11. the ventilation and smoke dissipation (...)

BUILDING LAW

Requirements of the MBO and LBOs regarding smoke dissipation and ventilation

The following table gives an overview of the requirements in the individual federal state building regulations (LBOs) regarding smoke dissipation in stairwells. Please contact GEZE GmbH if you require information about smoke dissipation and ventilation in basements and lift shafts.

Note:

The following are currently relevant extracts. Continuous updates must be taken into account.

Federal state	Regulations	Dated	Smoke dissipation when?	Smoke dissipation where?	Smoke dissipation - how large?	Operating points where?	Ventilation	
	MBO (Model building regulations)	Version November 2000	For necessary internal stairways and necessary stairways in buildings more than 13m high	At the highest point	With a free cross-section of at least 1m ²	Ground floor and top landing	Necessary stairwells: On each above-ground storey, windows leading directly to the outside with a free cross-sectional area of at least 0.5m ² , which can be opened	
Baden-Württemberg	LBO (state building regulations)	Version March 2010	No provision for smoke dissipation / extraction -> for special buildings only					Adequate ventilation Toilets + bathrooms
Bavaria	LBO (state building regulations)	25 Febr. 2010	For necessary internal stairways and necessary stairways in buildings more than 13m high	At the highest point	With a free cross-section of at least 1m ²	Ground floor and top landing	Necessary stairwells: On each above-ground storey, windows leading directly to the outside with a free cross-sectional area of at least 0.5m ² , which can be opened	
Berlin	LBO (state building regulations)	7 June 2007	For necessary internal stairways and necessary stairways in buildings more than 13m high	At the highest point	With a free cross-section of at least 1m ²	Ground floor and top landing	Necessary stairwells: On each above-ground storey, windows leading directly to the outside with minimum size 0.6m x 0.9m (width x height), which can be opened and have a sill height not greater than 1.20m	
Brandenburg	LBO (state building regulations)	13 April 2010	For necessary internal stairways and necessary stairways in buildings more than 13m high. Not for residential buildings with less than 2 flats	At the highest point	With a free cross-section of at least 1m ²	Ground floor and top landing	Necessary stairwells: On each above-ground storey, windows leading directly to the outside with a free cross-sectional area of at least 0.5m ² , which can be opened	
Bremen	LBO (state building regulations)	6 October 2009	For necessary internal stairways and necessary stairways in buildings more than 13m high. Not for residential buildings with less than 2 flats	At the highest point	With a free cross-section of at least 1m ²	Ground floor and top landing	Necessary stairwells: On each above-ground storey, windows leading directly to the outside with a free cross-sectional area of at least 0.5m ² , which can be opened	

- Continued overleaf -

BUILDING LAW

Requirements of the MBO and LBOs regarding smoke dissipation and ventilation

– Continued –

Federal state	Regulations	Dated	Smoke dissipation where?	Smoke dissipation where?	Smoke dissipation - how large?	Operating points where?	Ventilation
Hamburg	LBO (state building regulations)	11 May 2010	For necessary internal stairways and necessary stairways in buildings more than 13m high	At the highest point	With a free cross-section of at least 1m ²	Ground floor and top landing	Necessary stairwells: On each above-ground storey, windows leading directly to the outside with a free cross-sectional area of at least 0.5m ² , which can be opened
Hesse	LBO (state building regulations)	15 December 2009	For necessary internal stairways Class 5 buildings	At the highest point	With a free cross-section of at least 1m ²	Ground floor and top landing	Necessary stairwells: On each above-ground storey, windows leading directly to the outside with a free cross-sectional area of at least 0.5m ² , which can be opened
Mecklenburg-West Pomerania	LBO (state building regulations)	18 April 2006	For necessary internal stairways and necessary stairways in buildings more than 13m high	At the highest point	With a free cross-section of at least 1m ²	Ground floor and top landing	Necessary stairwells: On each above-ground storey, windows leading directly to the outside with a free cross-sectional area of at least 0.5m ² , which can be opened
Lower Saxony	LBO (state building regulations)	28 October 2009	No statement regarding smoke dissipation / smoke extraction				Stairways must be able to be ventilated
North Rhine-Westphalia	LBO (state building regulations)	17 December 2009	Building with more than 5 storeys above the ground and in case of necessary internal stairways	At the highest point of the stairwell	With a free cross-section of at least 5% of the floor area; however, at least 1m ²	Ground floor and top landing. Further operating points can be approved.	Necessary stairwells: On each above-ground storey, windows leading directly to the outside with a free cross-sectional area of at least 0.5m ² , which can be opened
Rhineland-Palatinate	LBO (state building regulations)	27 October 2009	Buildings with more than 5 storeys above the ground and for necessary internal stairways, not located at the external wall	At the highest point of the stairwell	With a free cross-section of at least 5% of the floor area; however, at least 1m ²	Ground floor and top landing. Further operating points can be approved.	Stairways must be able to be ventilated On each above-ground storey of necessary stairways located at the external wall in building classes 4 + 5, must have windows leading directly to the outside with minimum size 0.6m x 0.9m (width x height), which can be opened and have a sill height not greater than 1.20m
Saarland	LBO (state building regulations)	21 November 2007	For necessary internal stairways and necessary stairways in buildings more than 13m high	At the highest point of the stairwell	With a free cross-section of at least 1m ²	Ground floor and top landing	Necessary stairwells: On each above-ground storey, windows leading directly to the outside with a free cross-sectional area of at least 0.5m ² , which can be opened
Saxony	LBO (state building regulations)	13 August 2009	For necessary internal stairways and necessary stairways in buildings more than 13m high	At the highest point	With a free cross-section of at least 1m ²	Ground floor and top landing	Necessary stairwells: On each above-ground storey, windows leading directly to the outside with a free cross-sectional area of at least 0.5m ² , which can be opened
Saxony-Anhalt	LBO (state building regulations)	20 December 2005	For necessary internal stairways and necessary stairways in buildings more than 13m high	At the highest point of the stairwell	With a free cross-section of at least 1m ²	Ground floor and top landing	Necessary stairwells: On each above-ground storey, windows leading directly to the outside with a free cross-sectional area of at least 0.5m ² , which can be opened
Schleswig-Holstein	LBO (state building regulations)	9 March 2010	For necessary internal stairways and necessary stairways in buildings more than 13m high	At the highest point of the stairwell	With a free cross-section of at least 1m ²	Ground floor and top landing	Necessary stairwells: On each above-ground storey, windows leading directly to the outside with a free cross-sectional area of at least 0.5m ² , which can be opened
Thuringia	LBO (state building regulations)	8 July 2009	For necessary internal stairways and necessary stairways in buildings more than 13m high	At the highest point of the stairwell	With a free cross-section of at least 1m ²	Ground floor and top landing	Necessary stairwells: On each above-ground storey, windows leading directly to the outside with a free cross-sectional area of at least 0.5m ² , which can be opened

BUILDING LAW

Requirements of the model special building code

Special regulations exist, among other things, for the following special buildings:

- High-rise buildings
- Accommodation facilities (hotels, etc.)
- Sales premises
- Assembly places
- Schools
- Hospitals
- Industrial buildings

Note:

The following are currently relevant extracts. Continuous updates must be taken into account.

Special building code	Dated	Annex
Model school construction guidelines	Version July 1998	Smoke extraction
Model sales premises regulations	Version September 1995	Smoke extraction and ventilation
Model assembly place regulations	Version June 2005	Smoke dissipation, smoke extraction and ventilation
Model hospital building code	Version December 1976	Smoke dissipation and ventilation
Model industrial construction guidelines	Version March 2000	Smoke dissipation, smoke extraction and ventilation
Model high-rise building guidelines	Version May 2008	Smoke dissipation, smoke extraction and ventilation

CONSTRUCTION PRODUCTS LAW

Construction products law

The construction products law stipulates the requirements for construction products.

EN 12101, Part 2

Legal basis

The harmonised EN 12101 Part 2 defines the requirements for the SHEV building product and stipulates its testing, classification and CE marking. The objective of the CE marking is to make the import and export of goods within the EU easier.

The standard sets the following requirements for the testing and classification of the SHEVs:

- Determination of the aerodynamically effective opening area
- Checking the reliability
- Functional test under load
- Functional test at low ambient temperature
- Stability check under wind loads
- Checking the effect of heat

Certification to EN 12101 Part 2

The conformity procedure of EN 12101-2 is described in Annex ZA.

Product	Intended use	Conformity certification system
Natural smoke and heat extraction units	Fire protection	1

Annex ZA to this standard defines the following mandatory requirements:

- Initial type test (ITT)
- Factory production control (WPK)
- Initial visit and routine external monitoring by notified body

CONSTRUCTION PRODUCTS LAW

GEZE drives certified to EN 12101 Part 2 and tested GEZE SHEVs can be installed, are shown separately in Chapter 6ff. For a more precise system description and more detailed information on the topic of SHEV you can refer to the GEZE SHEV system document.

Further important guidelines are **MLAR** (Model Cable Systems Guidelines - "Musterleitungsanlagen-Richtlinie") and **DIN VDE 0833: Requirements for cables - MLAR (Version March 2000)**. According to the model cable systems guidelines (MLAR), functional endurance classification E30 is sufficient for natural smoke extraction systems. These cables must be tested and approved according to DIN 4102 Part 12. The cables must be laid according to the specifications of the cable manufacturer, with the appropriate fixing materials.

Exceptions according to the MLAR (Version March 2000)

Functional endurance for the RWA cables is not necessary if a fire early detection release element with SMOKE variable (smoke detector) monitors the complete cable route and release of the automatic detector results in opening of the RWA. The practical consequence of this is: Rooms through which an RWA cable is routed and in which RWA components are installed must be monitored by smoke detectors if the cable is not laid to E30 standard.

Concealed, flush laying

It must be noted that concealed, flush laying (under plaster) is not an approved type of laying to achieve functional endurance based on DIN 4102 Part 12. If the functional endurance requirement is to be fulfilled with concealed cables, they must also be to classification E30 or the room must be secured by smoke detectors.

Operating time

Referring to **DIN VDE 0833-2 (6.1.6 / 2004)**, in the event of a power failure, the RWA must also be able to "at least maintain operation for an operating period of 72 hours".

SERVICING AND MAINTENANCE

Servicing and maintenance

According to the MBO, owners and clients are obliged to ensure proper maintenance, as "buildings and structures ...() shall be arranged, built, modified and maintained so that public safety and order, especially life, health and natural habitats and livelihoods are not endangered". Construction projects may not be used without proper maintenance (**cf. §3 Para. 1 and 2 MBO**).

The client or owner shall independently ensure servicing, maintenance and inspection. All structural members and components shall be regularly checked for damage or deformations.

The owner/operator of an RWA system is obliged to take all necessary safety precautions to avert hazards endangering people and property in the building.

By ensuring the function of the smoke and heat extraction systems through regular maintenance, they decisively reduce the actual risk of damage and injuries and also reduce the risk of liability in the event of an incident or claim. In this way they can document at any time that they have fulfilled their obligation to keep the RWA systems ready for use and operation.

A selection of regulations and laws

Constitutional law Art. 2:

"Each person has the right to freedom from bodily harm."

MBO § 3, Para. 1 (Version November 2002)

"Facilities shall arranged, built, modified and maintained so that public safety and order, especially life, health or natural habitats and livelihoods are not endangered."

MBO § 14 (Version November 2002)

"Building systems are to be arranged, built, modified and maintained in such a way that the occurrence of a fire and the spreading of fire and smoke (fire spreading) is prevented and the rescue of people and animals and, in the event of a fire, effective fire fighting is possible."

SERVICING AND MAINTENANCE**DIN VDE 0833-1 (5.3.4 / 2003)**

“Maintenance must be carried out according to the manufacturer's instructions – taking into account the particular operating conditions - however, at least annually.”

DIN 18232 Part 2 (Version November 2007)

At regular intervals according to the manufacturer's instructions, usually once a year, smoke extraction systems and their actuators and controls, opening units, power supply cables and their accessories must be inspected to ensure they are in good working order and ready for operation and if necessary must be repaired. The inspections and maintenance work must be noted in an inspection log. Inspections are to be carried out by specialist firms qualified for NRA only.

Regulations concerning the monitoring of building services systems

Supplementary to the regular annual maintenance, RWA in so-called buildings and structures of a special type and use, e.g. commercial properties (office blocks with or without shops), assembly places, large garages, must be inspected at three-year intervals by a competent expert licensed under the building legislation/by the state. Regular maintenance is an essential prerequisite for these statutory inspections. The maintenance firm usually undertakes the obligation of the owner/operator to providing suitable qualified personnel for the inspection of the systems by the competent expert. In the inspection regulations for technical systems and building services of the individual federal states, the requirement for maintenance and servicing is specified separately.

Therefore, the following points should be guaranteed with respect to the servicing and maintenance of RWA systems:

- RWA systems are to be serviced and if necessary repaired at least once a year.
- The servicing/maintenance may only be carried out by competent, qualified persons. This competence must be verified. Authorisation must be given by GEZE.
- Inspections must be noted in an inspection log.

Assistance during installation and startup

GEZE offers system advice assistance, either by authorised partner firms or personnel from the head office. The installation and functional testing of an RWA must always be carried out by the manufacturer or a specialist firm authorised by the manufacturer, as this is the only way to ensure that the system-relevant functions are completely fulfilled. The RWA acceptance must be accepted by a competent expert.



Steps for RWA system design

Calculation of the smoke extraction area

Smoke extraction is the removal of smoke in case of fire (hot smoke removal). A stable, low-smoke layer results close to the floor which enables safe use of escape routes. A SHEV in accordance with EN 12101 Part 2 must, in Germany, always be used if natural "smoke extraction" is required by the building regulations. Cold smoke removal is used for smoke dissipation, used to remove the remaining smoke in the building after a fire. This is not a safety relevant construction product listed in construction regulations list C.

The smoke extraction area is calculated using the design group, room height and the height of the low-smoke layer from the relevant Table 3 of DIN 18232 Part 2 per smoke compartment. This total smoke extraction area is then divided between an appropriate number of façade openings and skylights (NRA: natural smoke extraction).

The relevant regulations provided by the standard must be taken into account.

The façade openings determined in this way should each be installed with a maximum distance of 0.5 m between the top edge of the façade openings and the ceiling in at least two opposite external walls of a smoke compartment. The façade openings should be located completely in the smoke compartment; the bottom edge of the discharge opening should be at least 0.5 m above the limit of the calculated low-smoke layer (in accordance with table 3, DIN 18232 Part 2).

Calculation of the fresh air area

The fresh air areas must be located completely within the low-smoke layer and be at least 1.5 times the size of the exhaust air area. In addition, the correction factors in accordance with EN 18232-2 must be noted and taken into account.

The top edge of the fresh air opening must be at least 1 m from the smoke layer limit. In the area of doors or windows with maximum 1.25 m width, this distance can be reduced to 0.5 m. It must always be ensured that the inflowing air does not flow directly into the smoky gas layer and that this impetus does not cause swirling of the smoky gases. The fresh air must be fed into the building close to the floor and at the greatest possible distance from the smoky gas layer.

Various systems are available as drive units for exhaust air and fresh air openings. Linear, spindle, scissor stay and chain drives have been tried and tested in practice for many years and nowadays represent state of the art standards. The different systems are available in different performance classes. Depending on the opening system (dimensions, weight, installation situation), a drive can be selected which guarantees perfect functional safety for years.

Design of the control

The RWA emergency power control unit is the central control unit to which all components are connected. In case of a fire they provide the power supply for the RWA openings for at least 72h via rechargeable batteries. Therefore, the power consumption of the individual components must be determined during the planning and the performance class of the central control unit must be selected accordingly.

Planning the wiring

According to the model cable systems guidelines (MLAR), functional endurance classification E30 is sufficient for natural smoke extraction systems. These cables must be tested and approved according to DIN 4102 Part 12. The cables must be laid according to the specifications of the cable manufacturer, with the appropriate fixing materials.

Exceptions according to the MLAR (Version March 2000):

Functional endurance for the RWA cables is not necessary if a fire early detection release element with SMOKE variable (smoke detector) monitors the complete cable route and release of the automatic detector results in opening of the RWA. The practical consequence of this is: Rooms through which an RWA cable is routed and in which RWA components are installed must be monitored by smoke detectors if the cable is not laid to E30 standard.

Concealed, flush laying: It must be noted that concealed, flush laying (under plaster) is **not** an approved type of laying to achieve functional endurance based on DIN 4102 Part 12. If the functional endurance requirement is to be fulfilled with concealed cables, they must also be to classification E30 or the room must be secured by smoke detectors.

You will find more product information in the relevant brochures, see ID numbers.

Door technology

01	Overhead door closers ID 091593, ID 091594
02	Hold-open systems ID 091593, ID 091594
03	Integrated door closers ID 091609
04	Floor springs ID 091607
05	Sliding door gear systems and linear guides ID 123605, ID 008770, ID 000586

Automatic door systems

06	Swing doors ID 144785
07	Sliding, telescopic and folding doors ID 143639
08	Circular and semi-circular sliding doors ID 135772
09	Revolving doors ID 132050
10	Actuation devices and sensors ID 142655

Smoke and heat extraction and window technology

11	Fanlight opening systems ID 127787
12	Electric opening and locking systems ID 127785, ID 127789
13	Electrical spindle and linear drives ID 127785, ID 127789
14	Electric chain drives ID 127785, ID 127789
15	Smoke and heat extraction systems ID 127785, ID 139075

Safety technology

16	Emergency exit systems ID 132408
17	Access control systems ID 132158
18	Panic locks ID 132848
19	Electric strikes ID 148666
20	Building management system ID 132408

Glass systems

21	Manual sliding wall systems (MSW) ID 104377
22	Integrated all-glass systems (IGG) ID 104366
23	GEZE Patch fittings mono glass systems ID 122521



POTENTIAL APPLICATIONS OF GEZE PRODUCTS



Door technology

The functionality, superior performance and reliability of GEZE door closers are impressive. A common design across the range, the ability to use them on all common door leaf widths and weights, and the fact that they can be individually adjusted makes their selection simple. They are continually being improved and enhanced with up-to-date features. For example, the requirements of fire protection and accessibility are fulfilled with a door closer system.

Automatic door systems

GEZE automatic door systems open up a huge variety of options in door design. The latest, innovative high-performance drive technology, safety, ease of accessibility and first class universal drive design set them apart. GEZE offers complete solutions for individual requirements. A dedicated division is responsible for the development and construction of individual special designs.

Smoke and heat extraction and window technology

GEZE smoke and heat extraction systems and ventilation technology provide complete systems solutions combining the many requirements of different types of windows. We supply a full range from energy efficient drive systems to natural ventilation and complete solutions for supplying and extracting air, also as certified SHEVs.

Safety technology

GEZE safety technology sets the standards where preventative fire protection, access control and anti-theft security in emergency exits are concerned. For each of these objectives GEZE offers tailored solutions, which combine the individual safety requirements in one intelligent system and close doors and windows in case of danger in a coordinated manner.

Building systems

In GEZE's Building Management System GEZE door, window and safety products can be integrated in to the security and control systems of the building. A central control and visualisation system monitors various automation components in the building and offers security through many different networking capabilities.

Glass systems

GEZE glass systems stand for open and transparent interior design. They can either blend discreetly into the architecture of the building or stand out as an accentuated feature. GEZE offers a wide variety of technologies for functional, reliable and aesthetic sliding wall or sliding door systems providing security with lots of design scope.

GEZE GmbH
P.O. Box 1363
71226 Leonberg
Germany

GEZE GmbH
Reinhold-Vöster-Straße 21-29
71229 Leonberg
Germany
Telefon +49 (0) 7152-203-0
Telefax +49 (0) 7152-203-310

www.geze.com

Germany
 GEZE Sonderkonstruktionen GmbH
 Planken 1
 97944 Boxberg-Schweigern
 Tel. +49 (0) 7930-92 94-0
 Fax +49 (0) 7930-92 94-10
 E-Mail: sk.de@geze.com

GEZE GmbH
 Niederlassung Nord/Ost
 Bühringstraße 8
 13086 Berlin (Weissensee)
 Tel. +49 (0) 30-47 89 90-0
 Fax +49 (0) 30-47 89 90-17
 E-Mail: berlin.de@geze.com

GEZE GmbH
 Niederlassung West
 Nordsternstraße 65
 45329 Essen
 Tel. +49 (0) 201-83 082-0
 Fax +49 (0) 201-83 082-20
 E-Mail: essen.de@geze.com

GEZE GmbH
 Niederlassung Mitte
 Adenauerallee 2
 61440 Oberursel (b. Frankfurt)
 Tel. +49 (0) 6171-63 610-0
 Fax +49 (0) 6171-63 610-1
 E-Mail: frankfurt.de@geze.com

GEZE GmbH
 Niederlassung Süd
 Breitwiesenstraße 8
 71229 Leonberg
 Tel. +49 (0) 7152-203-594
 Fax +49 (0) 7152-203-438
 E-Mail: leonberg.de@geze.com

GEZE Service GmbH NL Südwest
 Reinhold-Vöster-Straße 25
 71229 Leonberg
 Tel. +49 (0) 7152-92 33 34

GEZE Service GmbH NL Nord-Ost
 Bühringstraße 8
 13086 Berlin (Weissensee)
 Tel. +49 (0) 30-47 02 17 32

GEZE Service GmbH NL West
 Nordsternstraße 65
 45329 Essen
 Tel. +49 (0) 201-8 30 82 16

GEZE Service GmbH NL Mitte
 Feldbergstraße 59
 61440 Oberursel
 Tel. +49 (0) 6171-63 327-0

GEZE Service GmbH NL Süd
 Parking 17
 85748 Garching bei München 1
 Tel. +49 (0) 89-120 07 42-0

Austria
 GEZE Austria
 Wiener Bundesstrasse 85
 A-5300 Hallwang
 Tel. +43/6225/87180
 Fax: +43/6225/87180-299
 E-Mail: austria.at@geze.com

Baltic States
 GEZE GmbH Baltic States office
 Dzelzavas iela 120 S
 1021 Riga
 Tel. +371 (0) 67 89 60 35
 Fax +371 (0) 67 89 60 36
 E-Mail: office-latvia@geze.com

GEZE Benelux B.V.
 Steenoven 36
 5626 DK Eindhoven
 Tel. +31 (0) 40-26 290-80
 Fax +31 (0) 40-26 290-85
 E-Mail: benelux.nl@geze.com

Bulgaria
 GEZE Bulgaria - Trade
 Representative Office
 61 Pirinski Prohod, entrance „B“,
 4th floor, office 5,
 1680 Sofia
 Tel. +359 (0) 24 70 43 73
 Fax +359 (0) 24 70 62 62
 E-Mail: office-bulgaria@geze.com

China
 GEZE Industries (Tianjin) Co., Ltd.
 Shuangchenzhong Road
 Beichen Economic Development
 Area (BEDA)
 Tianjin 300400, P.R. China
 Tel. +86 (0) 22-26 97 39 95-0
 Fax +86 (0) 22-26 97 27 02
 E-Mail: Sales-info@geze.com.cn

GEZE Industries (Tianjin) Co., Ltd.
 Branch Office Shanghai
 Unit 25N, Cross Region Plaza
 No 899, Ling Ling Road,
 XuHui District
 200030 Shanghai, P.R. China
 Tel. +86 (0) 21-523 40 960
 Fax +86 (0) 21-644 72 007
 E-Mail: chinasales@geze.com.cn

GEZE Industries (Tianjin) Co., Ltd.
 Branch Office Guangzhou
 Room 17C3
 Everbright Bank Building, No.689
 Tian He Bei Road
 510630 Guangzhou
 P.R. China
 Tel. +86 (0) 20-38 73 18 42
 Fax +86 (0) 20-38 73 18 34
 E-Mail: chinasales@geze.com.cn

GEZE Industries (Tianjin) Co., Ltd
 Branch Office Beijing
 Room 1001, Tower D
 Sanlitun SOHO
 No. 8, Gongti North Road,
 Chaoyang District
 100027 Beijing, P.R.China
 Tel. +86 (0) 10-59 35 93 00
 Fax +86 (0) 10-59 35 93 22
 E-Mail: chinasales@geze.com.cn

France
 GEZE France S.A.R.L.
 ZAC de l'Orme Rond
 RN 19
 77170 Servon
 Tel. +33 (0) 1 60 62 60 70
 Fax +33 (0) 1 60 62 60 71
 E-Mail: france.fr@geze.com

Hungary
 GEZE Hungary Kft.
 Bartók Béla út 105-113.
 Budapest
 H-1115
 Tel. +36 (1) 481 4670
 Fax +36 (1) 481 4671
 E-Mail: office-hungary@geze.com

Iberia
 GEZE Iberia S.R.L.
 Pol. Ind. El Pla
 C/Comerc, 2-22, Nave 12
 08980 Sant Feliu de Llobregat
 (Barcelona)
 Tel. +34 9-02 19 40 36
 Fax +34 9-02 19 40 35
 E-Mail: info@geze.es

India
 GEZE India Private Ltd.
 MF 2 & 3, Guindy Industrial Estate
 Ekkattuthangal
 Chennai 600 097
 Tamilnadu
 Tel. +91 (0) 44 30 61 69 00
 Fax +91 (0) 44 30 61 69 01
 E-Mail: office-india@geze.com

Italy
 GEZE Italia Srl
 Via Giotto, 4
 20040 Cambiago (MI)
 Tel. +39 (0) 29 50 695-11
 Fax +39 (0) 29 50 695-33
 E-Mail: italia.it@geze.com

GEZE Engineering Roma Srl
 Via Lucrezia Romana, 91
 00178 Roma
 Tel. +39 (0) 6-72 65 311
 Fax +39 (0) 6-72 65 3136
 E-Mail: roma@geze.biz

Poland
 GEZE Polska Sp.z o.o.
 ul. Annapol 21
 03-236 Warszawa
 Tel. +48 (0) 22 440 4 440
 Fax +48 (0) 22 440 4 400
 E-Mail: geze.pl@geze.com

Romania
 GEZE Romania s.r.l.
 IRIDE Business Park,
 Str. Dimitrie Pompeiu nr. 9-9a,
 Building 10, Level 2, Sector 2,
 020335 Bucharest
 Tel.: +40 (0) 21 25 07 750
 Fax: +40 (0) 21 25 07 750
 E-Mail: office-romania@geze.com

Russian Federation
 GEZE GmbH Representative
 Office Russia
 Gamsonovskiy Per. 2
 115191 Moskau
 Tel. +7 (0) 495 933 06 59
 Fax +7 (0) 495 933 06 74
 E-Mail: office-russia@geze.com

Scandinavia – Sweden
 GEZE Scandinavia AB
 Mallslingan 10
 Box 7060
 18711 Täby, Sweden
 Tel. +46 (0) 8-7323-400
 Fax +46 (0) 8-7323-499
 E-Mail: sverige.se@geze.com

Scandinavia – Norway
 GEZE Scandinavia AB avd. Norge
 Industriveien 34 B
 2073 Dal
 Tel. +47 (0) 639-57 200
 Fax +47 (0) 639-57 173
 E-Mail: norge.se@geze.com

Scandinavia – Finland
 Branch office of GEZE Scandinavia AB
 Herralantie 824
 Postbox 20
 15871 Hollola
 Tel. +358 (0) 10-40 05 100
 Fax +358 (0) 10-40 05 120
 E-Mail: finland.se@geze.com

Scandinavia – Denmark
 GEZE Danmark
 Branch office of GEZE Scandinavia AB
 Märkærvej 13 J-K
 2630 Taastrup
 Tel. +45 (0) 46-32 33 24
 Fax +45 (0) 46-32 33 26
 E-Mail: danmark.se@geze.com

Singapore
 GEZE (Asia Pacific) Pte. Ltd.
 21 Bukit Batok Crescent
 #23-75 Wcega Tower
 Singapore 658065
 Tel: +65 6846 1338
 Fax: +65 6846 9353
 E-Mail: gezesea@geze.com.sg

South Africa
 GEZE Distributors (Pty) Ltd.
 118 Richards Drive, Halfway House,
 Ext 111, P.O. Box 7934, Midrand 1685,
 South Africa
 Tel: + 27 (0) 113 158 286
 Fax: + 27 (0) 113158261
 Email: info@gezesa.co.za

Switzerland
 GEZE Schweiz AG
 Bodenackerstrasse 79
 4657 Dulliken
 Tel. +41 (0) 62 285 54 00
 Fax +41 (0) 62 285 54 01
 E-Mail: schweiz.ch@geze.com

Turkey
 GEZE GmbH Türkiye - İstanbul
 İrtibat Bürosu
 Ataşehir Bulvarı, Ata 2/3
 Plaza Kat: 9 D: 84 Ataşehir
 Kadıköy / İstanbul
 Tel. + 90 (0) 21 64 55 43 15
 Fax + 90 (0) 21 64 55 82 15
 E-Mail: office-turkey@geze.com

Ukraine
 GEZE Ukraine TOV
 ul. Viskoznaya, 17,
 Building 93-B, Office 12
 02660 Kiev
 Tel./Fax +38 (0) 44 501 22 25
 E-Mail: office-ukraine@geze.com

United Arab Emirates/GCC
 GEZE Middle East
 P.O. Box 17903
 Jebel Ali Free Zone
 Dubai
 Tel. +971 (0) 4-88 33 112
 Fax +971 (0) 4-88 33 240
 E-Mail: geze@emirates.net.ae

United Kingdom
 GEZE UK Ltd.
 Blenheim Way
 Fradley Park
 Lichfield
 Staffordshire WS13 8SY
 Tel. +44 (0) 1543 44 30 00
 Fax +44 (0) 1543 44 30 01
 E-Mail: info.uk@geze.com

GEZE REPRESENTATIVE