

[www.maco.eu](http://www.maco.eu)

ASSEMBLY INSTRUCTIONS

# MULTI POWER

## Timber and PVC



Use  
**only for certified specialists!**



## Table of Contents

Item	Page
Important Information	4
Key and Abbreviations	5
General Processing Notes	6 - 10
Intended use	6
Application Notes	6 - 10
1-sash elements	11 - 34
<b>Turn-Tilt, Turn and Tilt&amp;Turn elements</b>	
Hardware overview, Application diagram	11 - 15
Hardware installation on the frame	16 - 21
Frame routing under FT24	22 - 23
Free dimensions	24
Assembly of pivot post and scissor stay arm with hinge	25 - 26
<b>Tilt elements</b>	
Hardware overview, Application diagram	27 - 29
Hardware installation on the frame	30 - 34
2-sash elements (French window elements)	35
Hardware overview	35
3-sash elements	36 - 45
Hardware overview, Application diagram	36 - 39
Hardware installation on the frame	40 - 43
Free dimensions	44
Assembly of corner, scissor stay hinge and assembly cover	45
Accessories, Special Solutions	46 - 71
Cover cap assembly	46
MULTI POWER with load-bearing	47 - 60
MULTI POWER in slim frame profiles	61 - 68
Turn restrictor MULTI POWER	69
MULTI POWER with opening restrictor	70
MULTI POWER with comfort stop	71



## Table of Contents

<b>Item</b>	<b>Page</b>
Supplementary Information	72 - 81
Hanging the sash in and out	72 - 79
Exchange of anti-slam device and scissor stay restrictor	80
Settings, Maintenance	81
Notes for security windows according to EN 1627	81

Additional assembly instructions for central lock (Order No. 757212) mandatory note!



## Important Information

### Target audience

This documentation is intended exclusively for specialist companies and certified specialists. The work-steps described herein may only be carried out by certified specialists.



















### Instructions for use

- Unless otherwise indicated, measurements are made in millimetres.
- Assemble all hardware parts professionally as described in these instructions and observe all safety instructions.
- All diagrams are only symbolic.
- Further technical documents can be found in our online catalogue (TOM) at [extranet.maco.eu](http://extranet.maco.eu)
- This print document is constantly being revised and is available for download in the current version under [www.maco.eu](http://www.maco.eu).
- Printing errors, mistakes and changes are reserved.
- Please send feedback or suggestions and ideas for improvements on our instructions by email to: [feedback@maco.eu](mailto:feedback@maco.eu).

### Material Notes

- The hardware parts described in this guide are made of stainless steel or galvanised passivated steel and sealed in accordance with DIN EN 12329. They must not be used in environments with aggressive, corrosive air content.
- Do not use acid-curing sealants, as these can lead to corrosion of the hardware parts.
- The window and casement door elements may only be surface-treated before the hardware is installed. Any subsequent surface treatment may restrict the functionality of the hardware. In this case, no warranty claims can be made against the hardware manufacturer.

## Key and Abbreviations

	Sash rebate height (SRH)		Handle height (GM)
	Sash rebate width (SRW)		Backset (DM)
	Sash rebate width and height		Rebate gap (FL)
	Maximum sash weight		Rebate leg (Ü)
	Turn Tilt element (DK)		Offset (V)
	Tilt Turn element (KD)		Rebate depth (FT)
	Turn element (DR)		MULTI-MATIC (MM)
	Corner element standard		MULTI-MATIC with tilt lock bolt (MM-KS)
	Corner element short		
	Drive motor fixed		
	Drive motor variable		

AWD = Application diagram

ZV = Central lock

## General Processing Notes

Intended use:

These assembly instructions for the hinge side MULTI POWER are binding. The use and assembly of the components is only permitted in the manner listed below. Any other use is not provided for and therefore does not correspond to the intended use. The following points also need to be considered:

- Information on application areas, sash weights and fabrication guidelines from profile manufacturers or system providers must be considered in a binding manner!
- The centre of gravity or position of the glass pane can affect application areas and max. weights and must be requested if necessary!

**In the event of non-compliance, the right to compensation will lapse!**

### Application Notes

#### 1 Application materials (frame material)

Timber\*

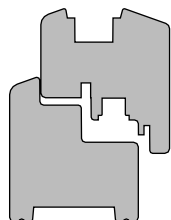

PVC

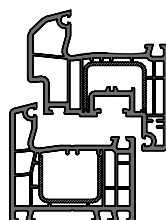

Aluminium\*\*

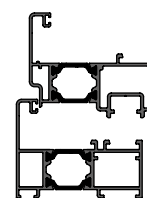

\* raw density  $\geq 0.5 \text{ g/cm}^3$

*Wraparound fitting groove!*

*Rebate width must be strong enough to withstand forces (pressure, etc.) and not break!*

\*\* only after consultation



**IMPORTANT!**

#### 2 Applications / Sash design

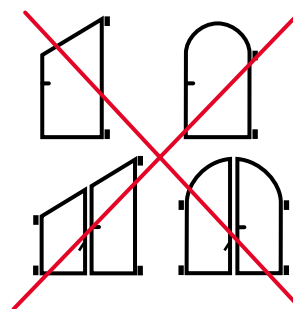
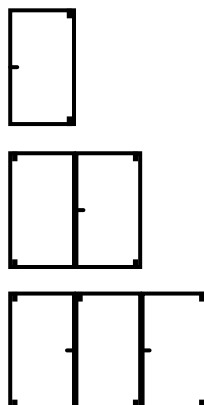

### 3 Window design

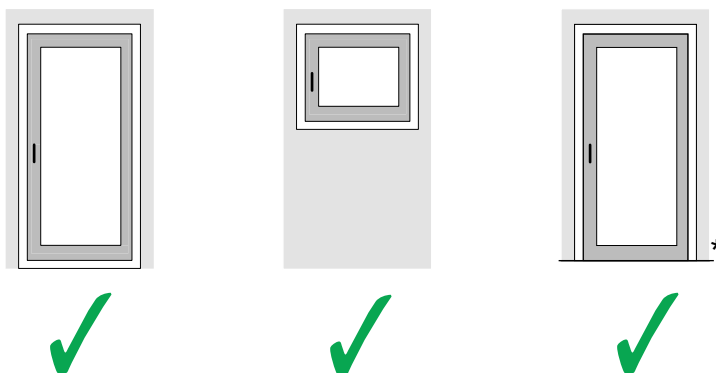

\* see assembly instructions MULTI POWER in floor thresholds (Order No. 758590)

### 4 Opening types

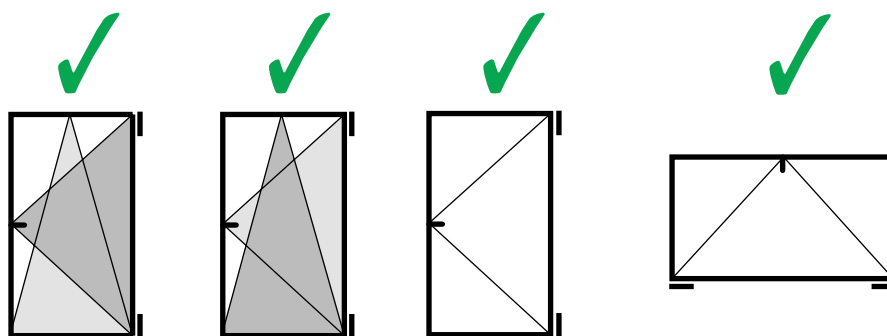

Opening width  $\leq 100^\circ$

### 5 Hardware program

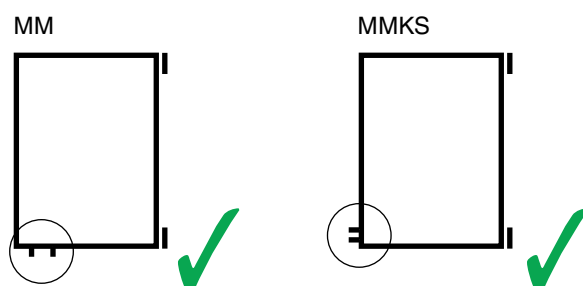

**6 Hardware overview (security)**

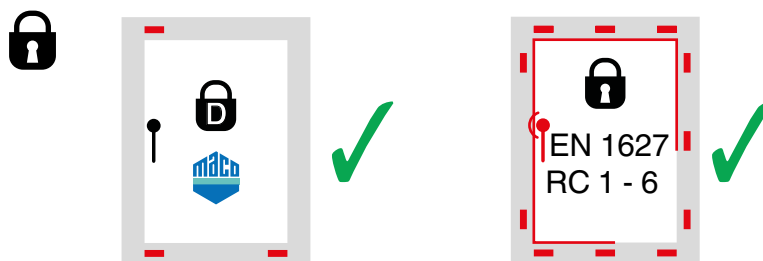

**7 Sash profile - Rebate gap, Rebate leg and Offset**

Timber with 4 mm rebate gap only on request!

4 / 15 - 9

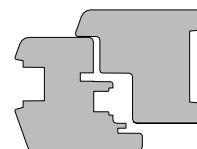

4 / 18 - 13

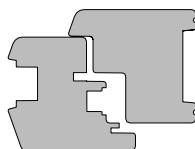

4 / 18 - 9

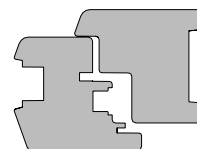

12 / 18 - 13

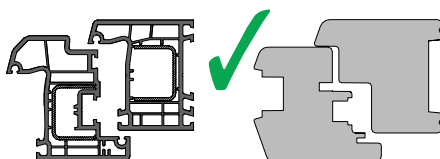

12 / 18 - 9

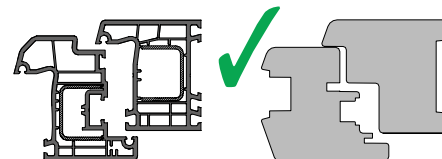

12 / 20 - 13

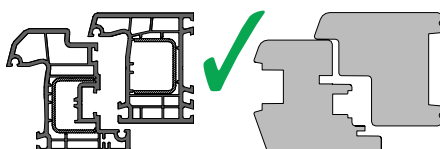

12 / 20 - 9

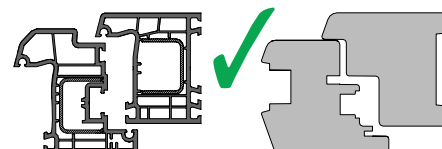

**IMPORTANT!**

Rebate gap below horizontal:  $\geq 12.0$  mm, with cover  $\geq 12.5$  mm



**IMPORTANT!**

Rebate gap to the side and above:  $\geq 12.0$  mm

**8 Fitting groove**

The fitting groove must be implemented according to the information in our print and online catalogues!

**9 Sash profile - rebate leg below (Tilt position)**

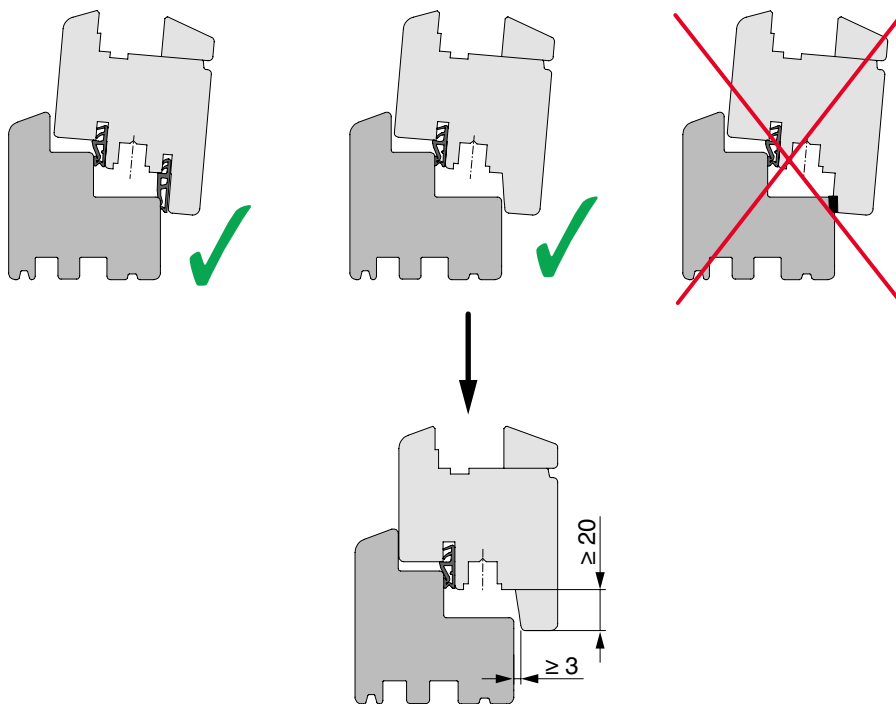

**DANGER!**

In the case of timber profiles without rebate leg gaskets, the rebate leg must be routed below to ensure an error-free tilting of the sash!

**10 Frame rebate**



**TIMBER!**

The pivot post must be fully flat!  
Glue grooves in frame!

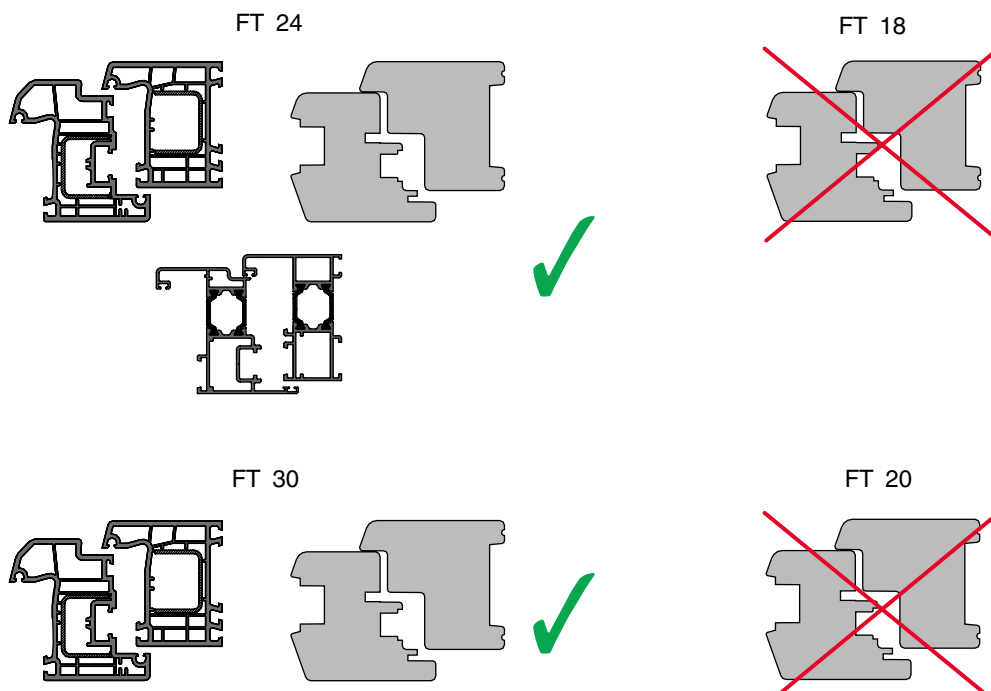

### 11 Screw dimension

For fixing the corner support and scissor stay support in timber and PVC profiles, a special screw  $\varnothing 4.5 \times 38$  mm, Article No. 362918 (Phillips) or 367828 (TX 20) must be used. Use a  $\varnothing 3.9 \times 25$  mm screw for fixing in aluminium.



#### DANGER!

The fixing of the bearing parts must meet the requirements of the TBDK guidelines (quality association for locks and hardware - [www.schlossindustrie.de](http://www.schlossindustrie.de)) or comply with EN 13126-8!



#### IMPORTANT!

Use screws as long as possible to fix the rebated corner support. At least  $\varnothing 4.0 \times 30$  mm!

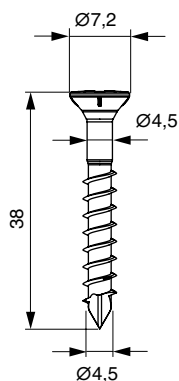
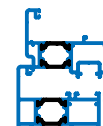
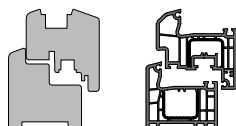

№ 362918

№ 367828

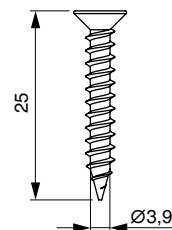

DIN 7982 C

With PVC, the fixing with screws must be done in the steel reinforcement! Any other case must be consulted with us!

For PVC profiles without steel reinforcement, see profile sheets or package leaflet Order No. 756991!

# 1-sash elements

## Hardware overview 1-sash Turn&Tilt and Tilt&Turn elements



### DANGER!

From 1301 mm SRW, use a stabilising scissor stay!



### ATTENTION!

Use a scissor stay restrictor for SRH  $\leq$  800 mm!



### DANGER!

From 150 kg sash weight, use load transfer device!



### DANGER!

To support the pivot post in timber with sash weights from 100 kg, use the support rawlplug Article No. 36668!

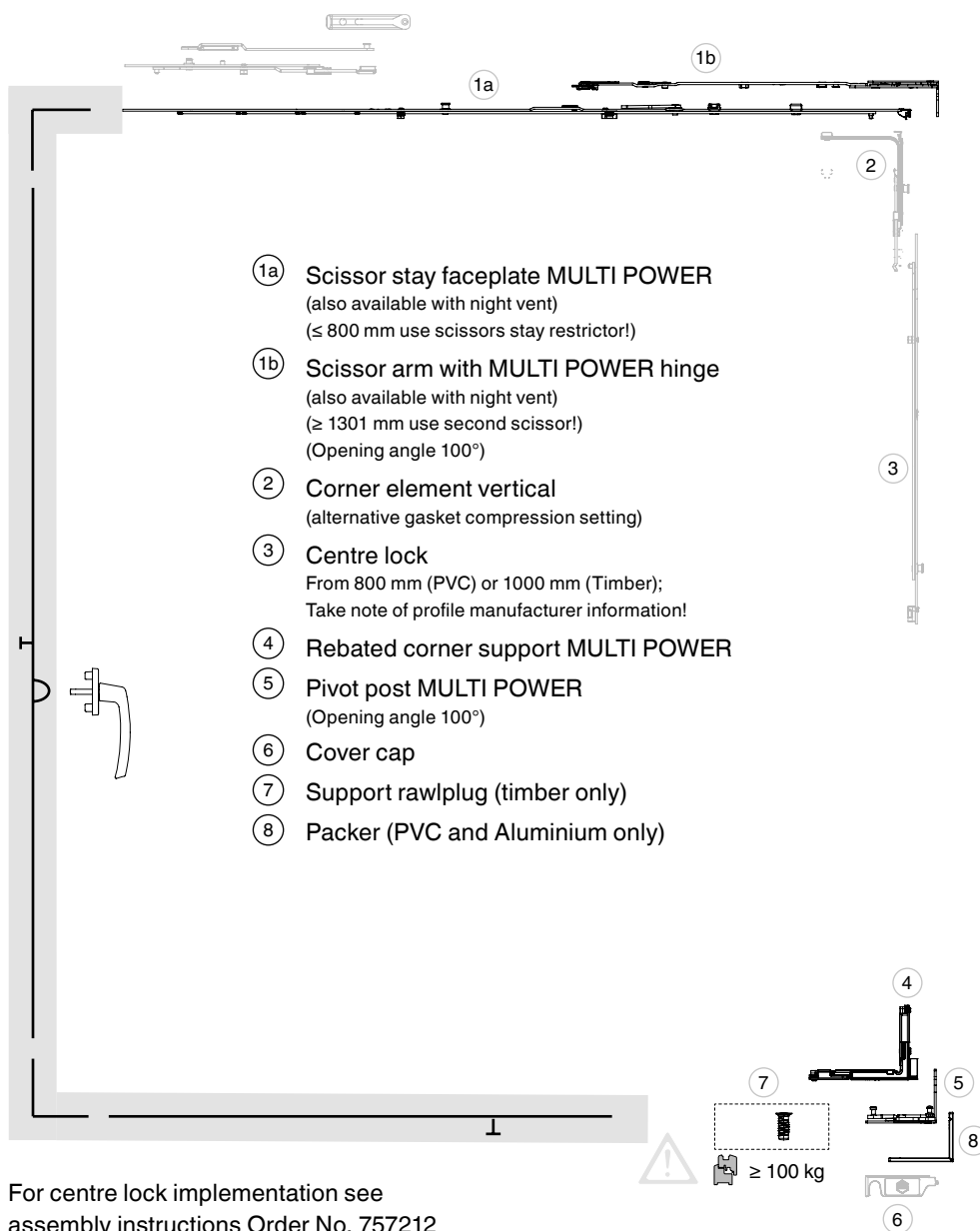

$\leq$  1650 x 2800 mm

$\geq$  465 mm

$\geq$  370 mm

$\geq$  360 mm (  $\updownarrow$  15 )  
  $\geq$  455 mm (  $\square$  6,5 )





$\geq$  470 mm (  $\updownarrow$  15 )  
  $\geq$  530 mm (  $\square$  6,5 )

$\geq$  270 mm (  $\updownarrow$  15 )  
  $\geq$  365 mm (  $\square$  6,5 )

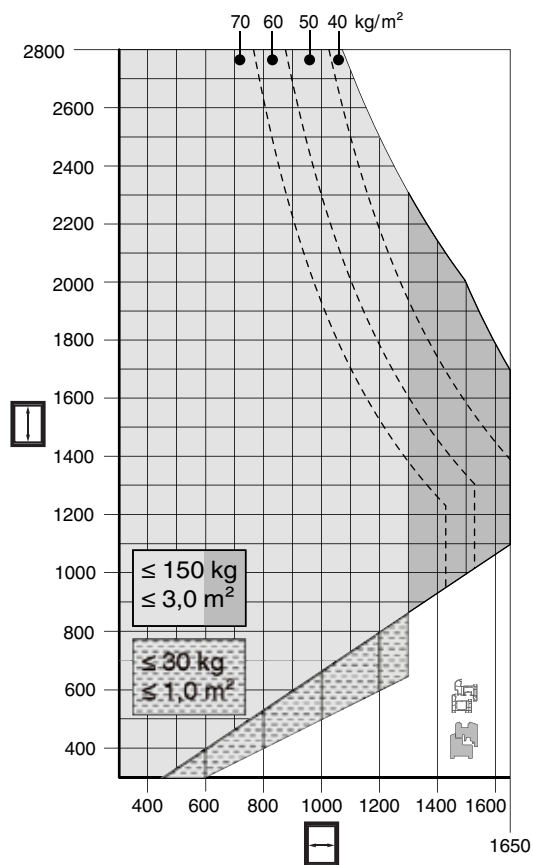
$\geq$  400 mm (  $\updownarrow$  15 )  
  $\geq$  460 mm (  $\square$  6,5 )

### Application diagram for turn&tilt and tilt&turn elements



-  Permissible area
-  Stabilising scissor stay required
-  Improper Area
-  for PVC profiles
-  for timber profiles

All notes on the use of application diagrams in our print and online catalogues must be considered!

## Hardware overview turn-only elements with variable length turn-only hinge



### DANGER!

To support the pivot post in timber with sash weights from 100 kg, use the support rawlplug Article No. 36668!

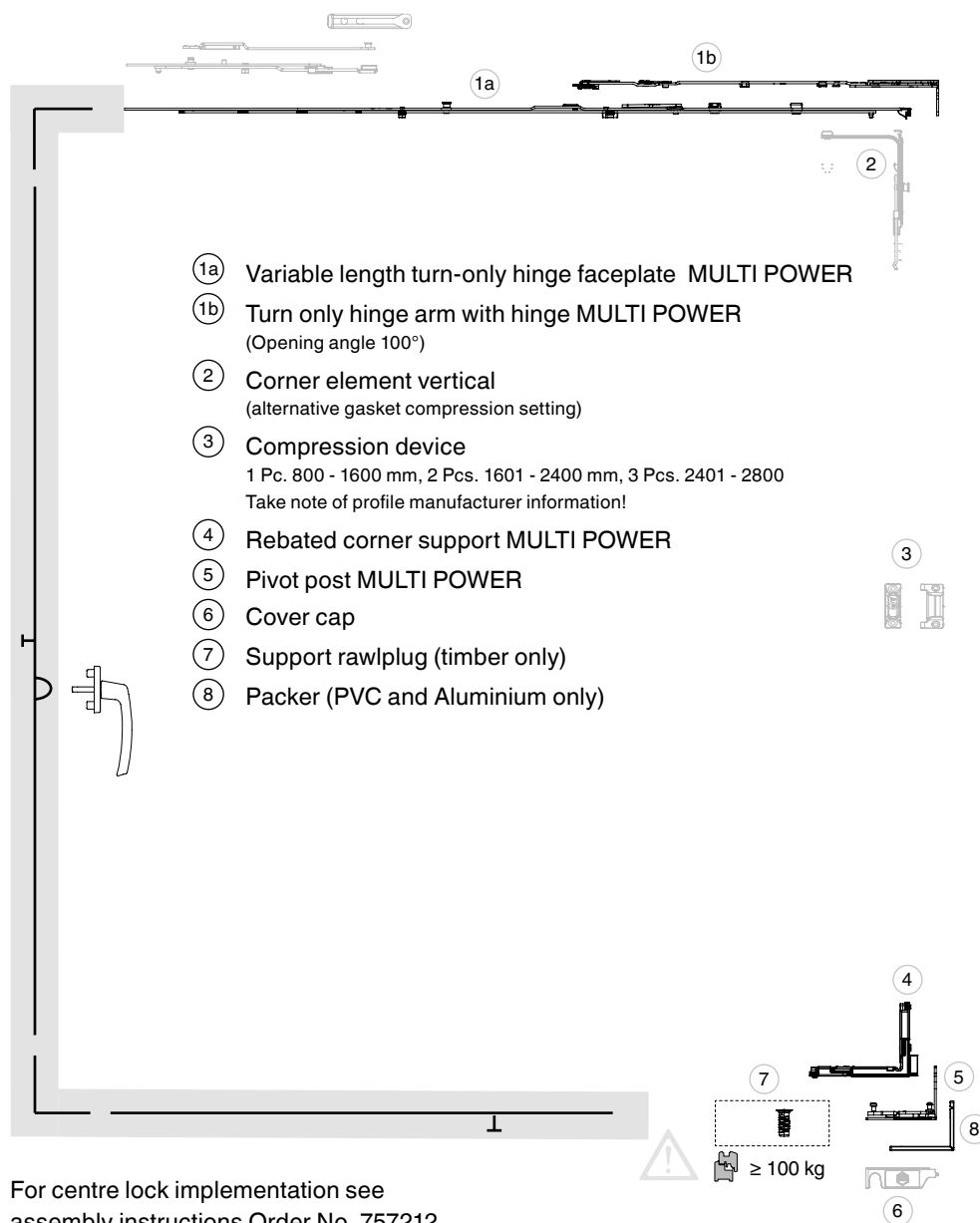

≤ 1650 x 2800 mm

≥ 465 mm

≥ 370 mm

≥ 360 mm ( 15 )  
≥ 455 mm ( 6,5 )

≥ 470 mm ( 15 )  
≥ 530 mm ( 6,5 )

≥ 270 mm ( 15 )  
≥ 365 mm ( 6,5 )

≥ 400 mm ( 15 )  
≥ 460 mm ( 6,5 )

## Hardware overview turn-only elements with fixed turn-only hinge







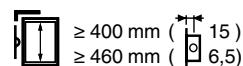
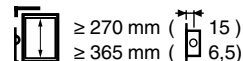
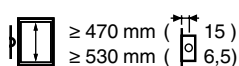
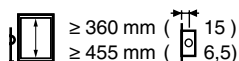
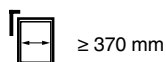
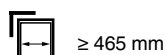
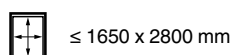
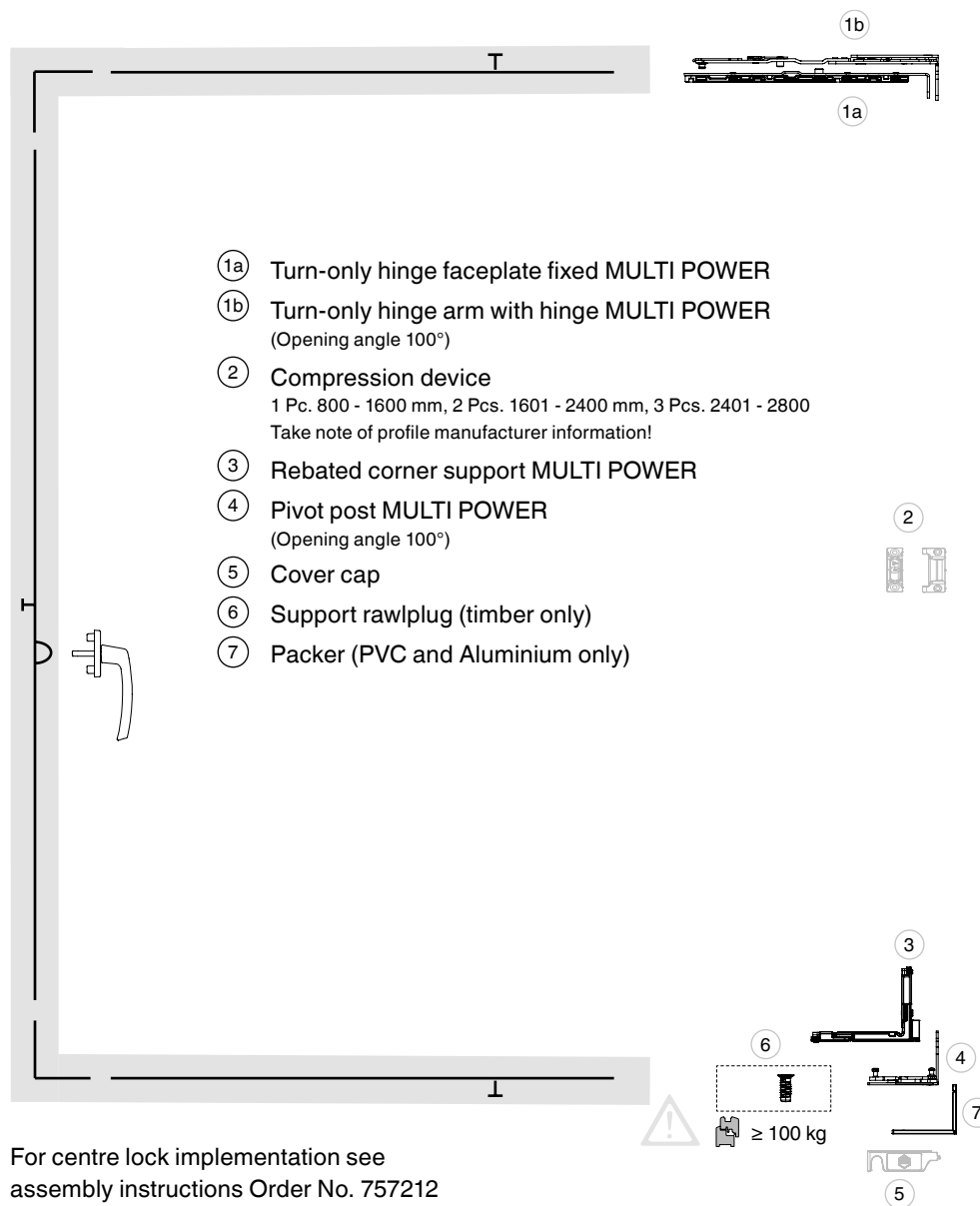

### DANGER!

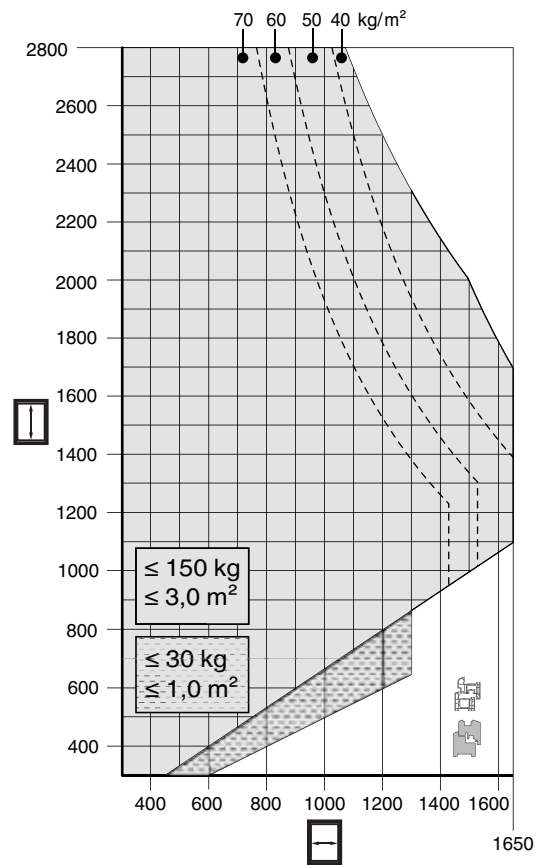
To support the pivot post in timber with sash weights from 100 kg, use the support rawplug Article No. 36668!



### Application diagram for turn-only elements



-  Permissible area
-  Stabilising scissor stay required
-  Improper Area
-  for PVC profiles
-  for timber profiles

All notes on the use of application diagrams in our print and online catalogues must be considered!

## Hardware installation on the frame

### Drilling with jig for pivot post and scissor stay support FT24

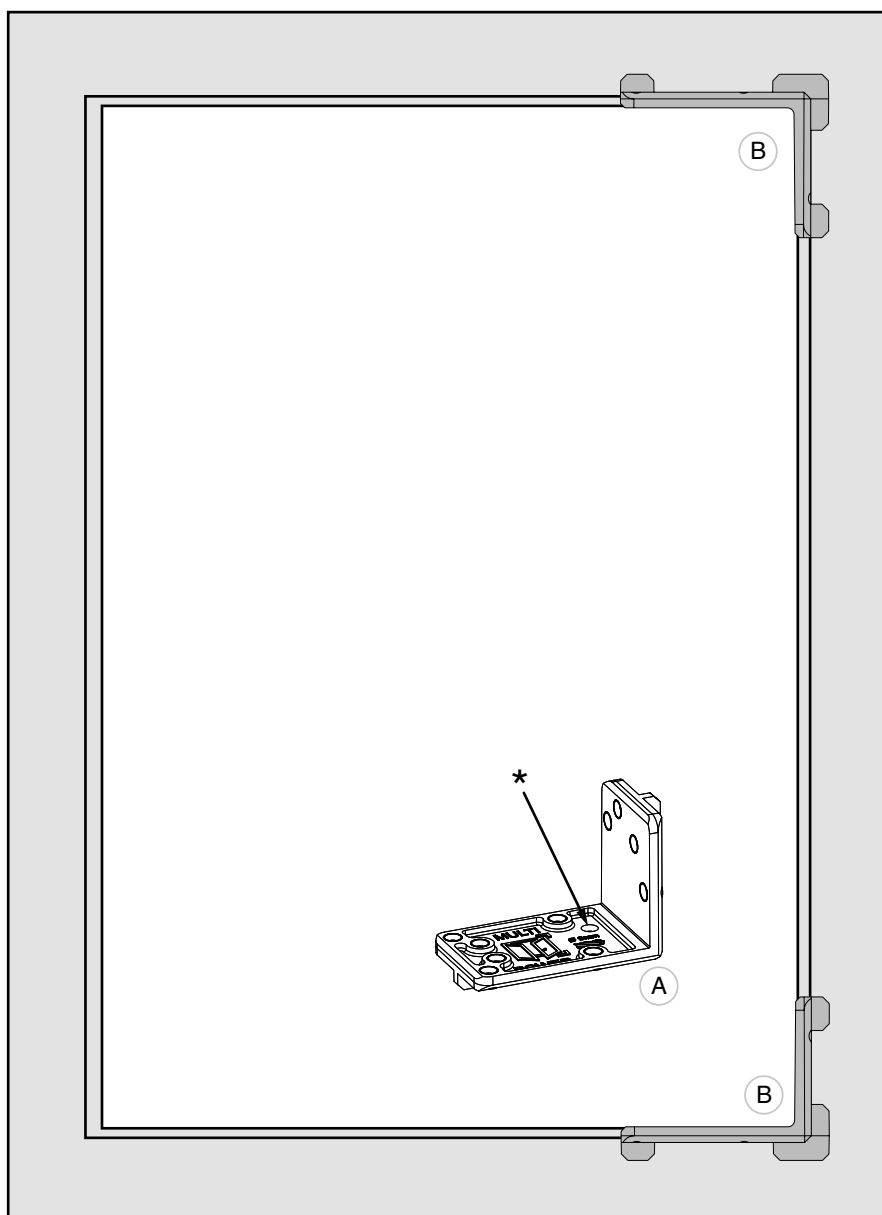

Insert drilling jig (A) for right sash (Article No. 217092) and left sash (Article No. 217093) in frame rebate corners (B) at the top and bottom and pre-drill with  $\varnothing 3$  mm drill.



**WARNING!**

\* For timber from 100 kg sash weight:  
Drilling for support rawplug Article No. 36668 with  $\varnothing 8$  mm drill, 21 mm deep.

Drilling image for scissor stay hinge MULTI POWER FT24 - 12 mm rebate gap

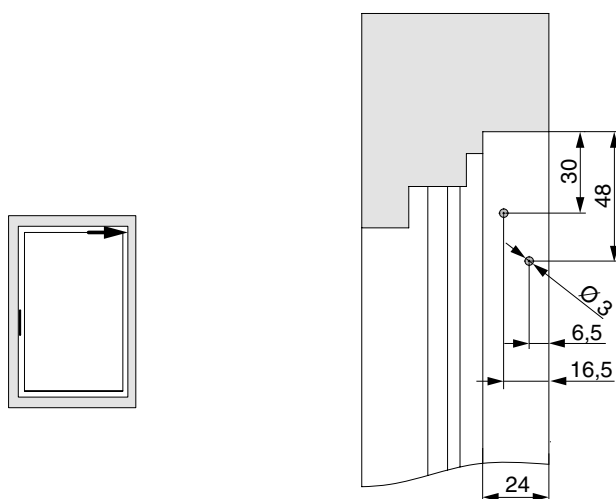
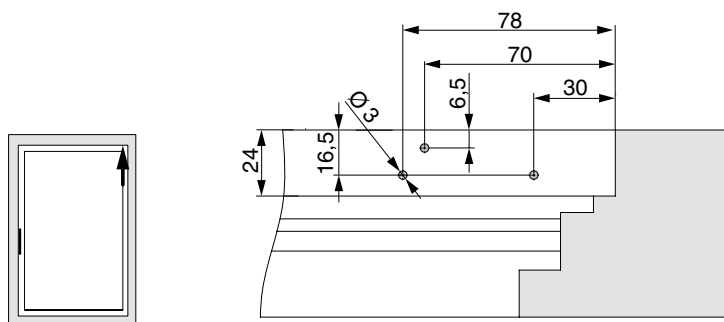

Drilling image for pivot post MULTI POWER FT24 - 12 mm rebate gap

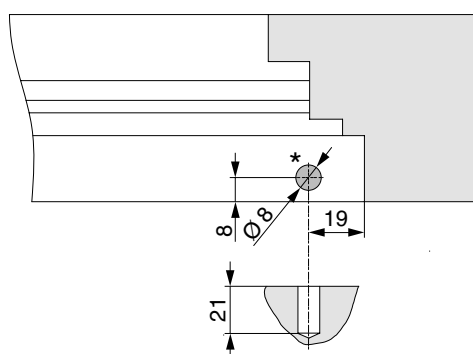
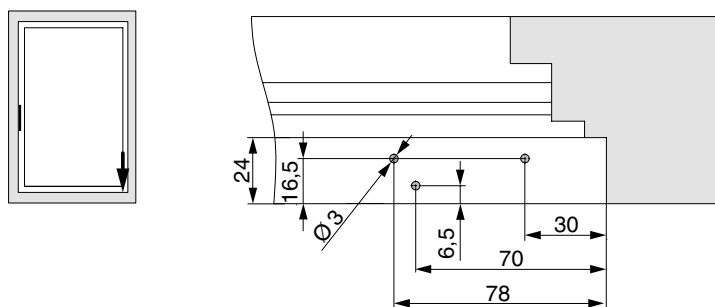
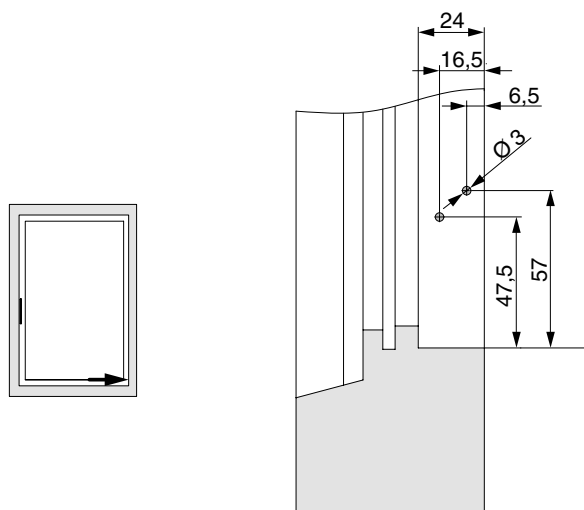

**WARNING!**

\* From 100 kg sash weight screw in support rawplug Article No. 36668 flush into the frame profile. Countersink for support rawplug where necessary.

### Drilling with jig for pivot post and scissor stay hinge FT30

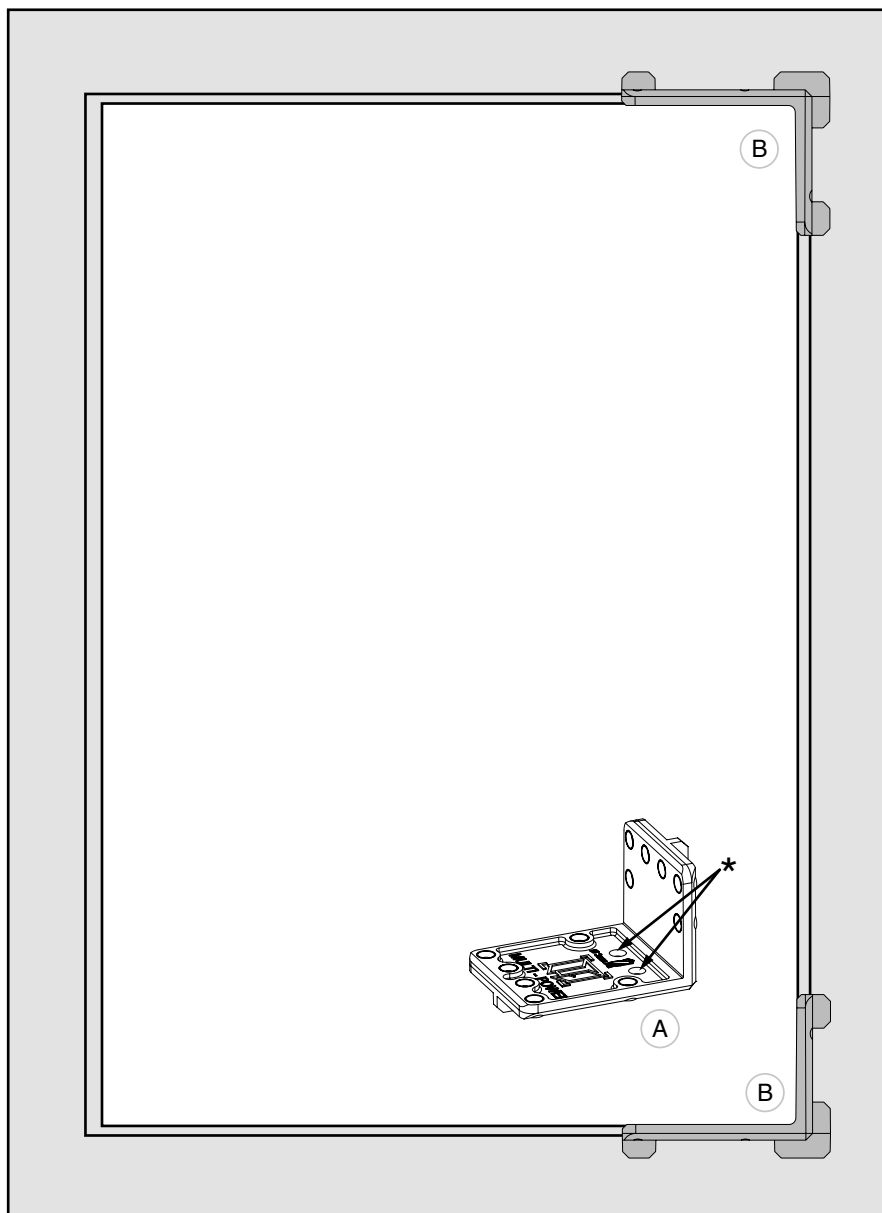

Insert drilling jig (A) for right and left sash (Article No. 217094) in frame rebate corners (B) at the top and bottom and pre-drill with  $\varnothing$  3 mm.



**WARNING!**

\* For timber from 100 kg sash weight:  
Drilling for support rawplug Article No. 36668 with  $\varnothing$  8 mm drill, 21 mm deep.

Drilling image for scissor stay hinge MULTI POWER FT30 - 12 mm rebate gap

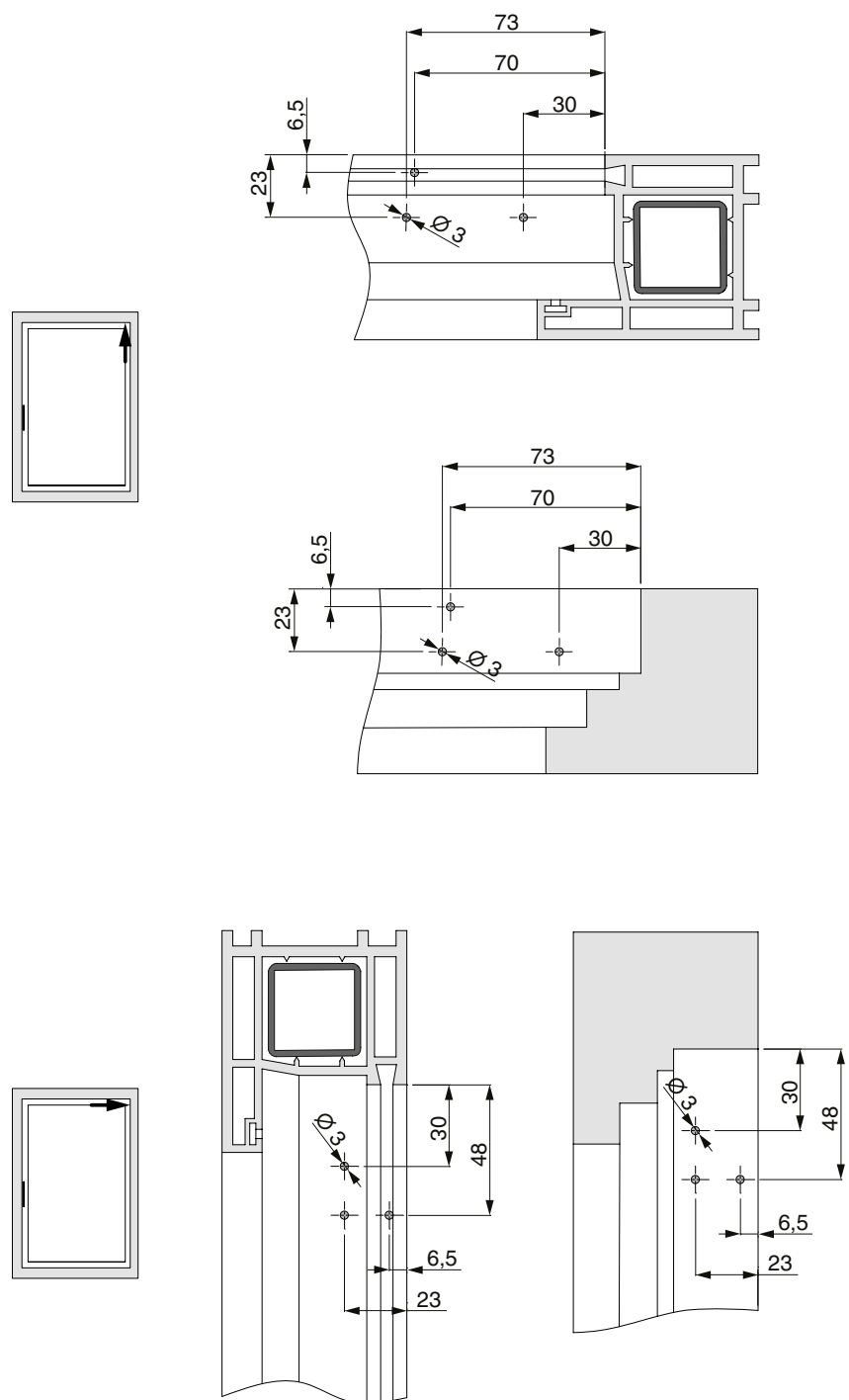

### Drilling image for pivot post MULTI POWER FT30 - 12 mm rebate gap



#### DANGER!

The fixing with screws must be done in the steel reinforcement.  
For profiles without steel reinforcement, see profile sheets or packing slip 756991!

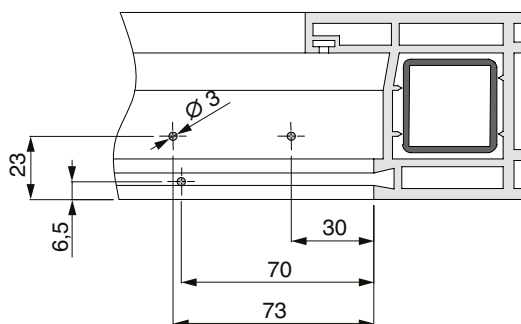
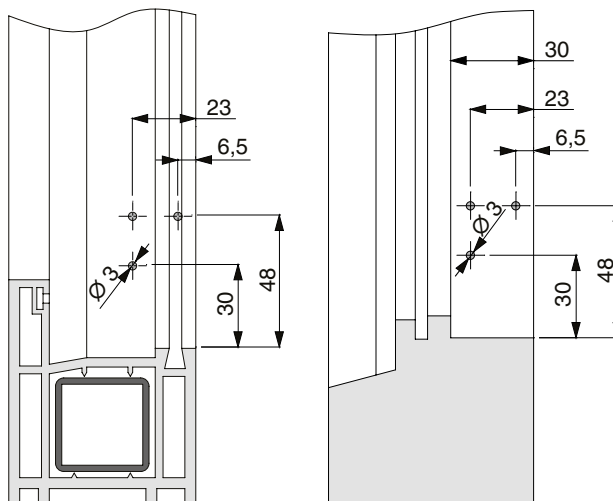
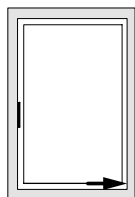

#### WARNING!

\* From 100 kg sash weight screw in support rawplug Article No. 36668 flush into the frame profile.  
Countersink for support rawplug where necessary.

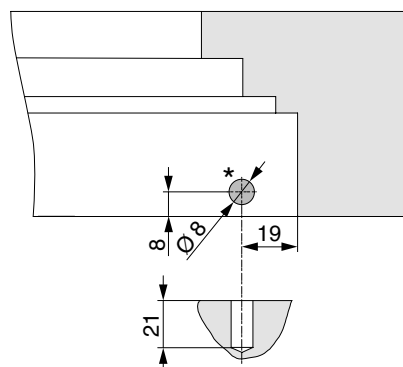
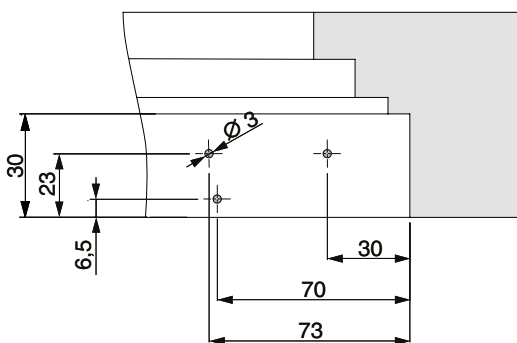
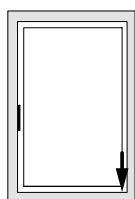

## Frame routing under FT24

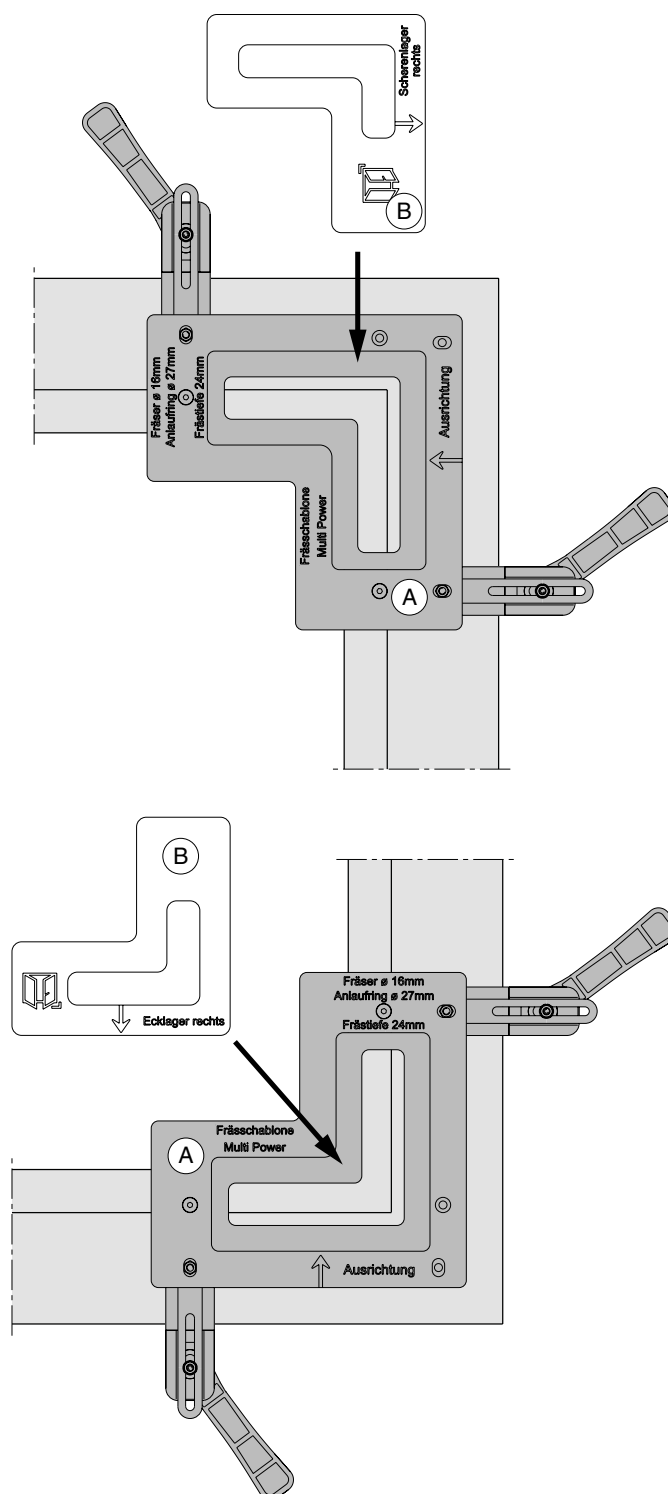

Place routing frame (A) Article No. 225618 in frame rebate corners and clamp. Place routing insert (B) scissor stay hinge Article No. 368036 or pivot post Article No. 368035 in frame profile and mill with Ø 16 mm cutter and Ø 27 mm copy ring.

**Routing pattern under FT24 pivot post and scissor stay hinge - 12 mm rebate gap**

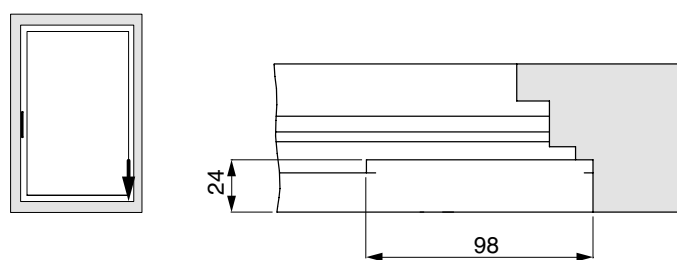
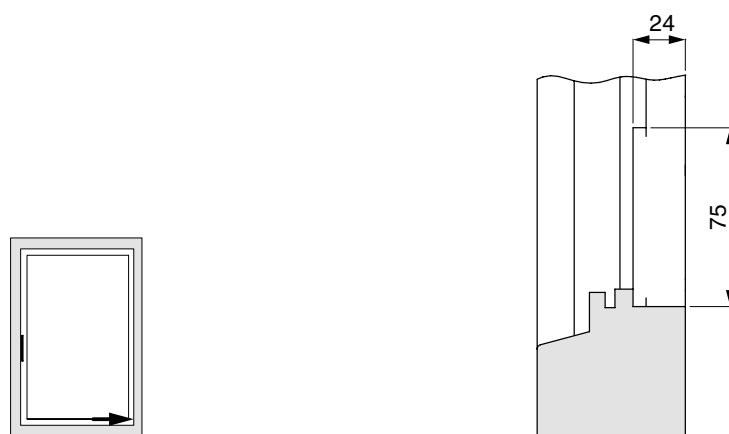
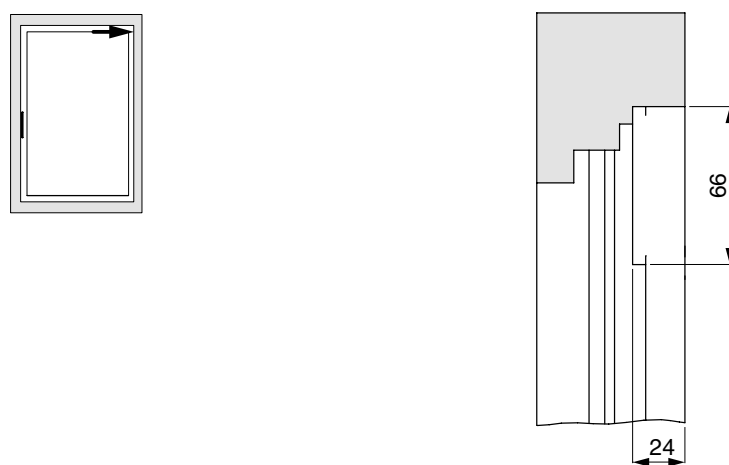
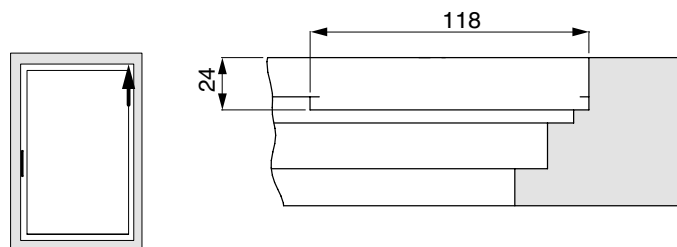

## Free dimensions

### Flush mounted profiles, 1-sash.

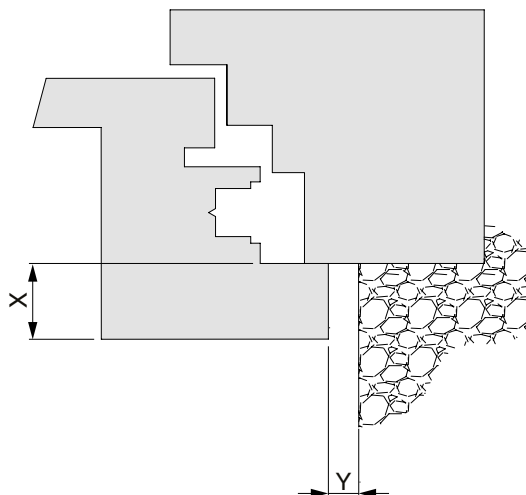

### Flush profiles, 1-sash.

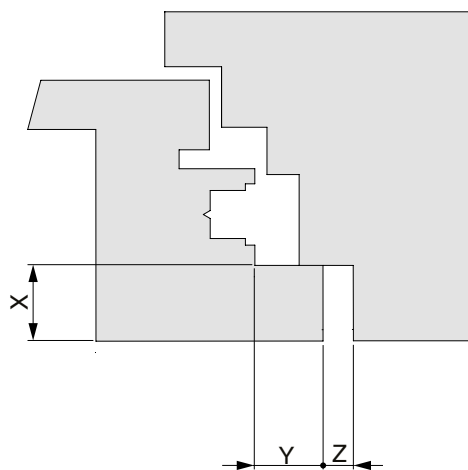

#### CAUTION!

The minimum free size depends on the version of the rebate leg (radius, varnish thickness...).

The values for Z in the table are without taking tolerances into account. We always recommend a customer-side check of the used profile in advance!

#### Values for Z

		X								
		16	17	18	19	20	21	22	23	24
Y	18Ü	4	4	4	6	7	8	9	10	12
	20Ü	4	4	4	4	5	6	7	8	10
	22Ü	4	4	4	4	4	5	6	7	8

## Assembly of pivot post and scissor stay arm with hinge



### DANGER!

The fixing with screws must be done in the steel reinforcement. For profiles without steel reinforcement, see profile sheets or packing slip 756991!



### DANGER!

The fixing of the bearing parts must meet the requirements of the TBDK guidelines (quality association for locks and hardware - [www.schlossindustrie.de](http://www.schlossindustrie.de)) or comply with EN 13126-8!



### WARNING!

\* From 100 kg sash weight, screw in Article No. 36668 flush in the frame profile. Countersink for support rawlplug where necessary.



### WARNING!

Use profile specific packers for PVC and aluminum profiles according to the profile sheet!



### WARNING!

With timber, the pivot post must rest on the entire surface!  
Glue grooves (Eurogroove, groove for frame gasket).

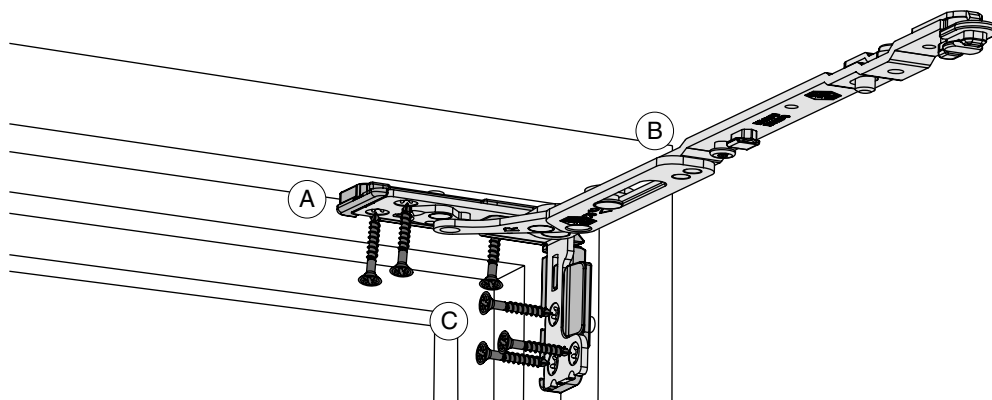

1. Insert the packer (A) on the baseplate (only for PVC and Aluminium).
2. Insert scissor stay arm with hinge (B) opened in frame rebate corner and fix using special screw  $\varnothing$  4.5 x 38 mm (C) (Article No. 362918 and 367828)!

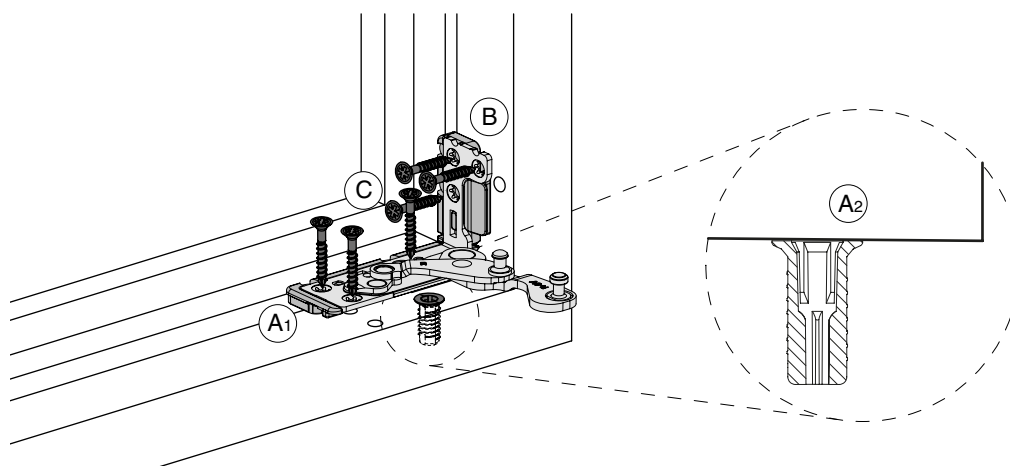

- 1a. Insert the packer (A1) on the baseplate (only for PVC and Aluminium).
- 1b. If necessary, turn in flush the support rawlplug (A2) (only for timber).
2. Insert pivot post (B) opened in frame rebate corner and fix with special screw  $\varnothing$  4.5 x 38 mm (C) (Article No. 362918 and 367828)!

## Assembly of pivot post and scissor stay arm with hinge



### DANGER!

During the window assembly, the pivot post must be protected from construction dirt.

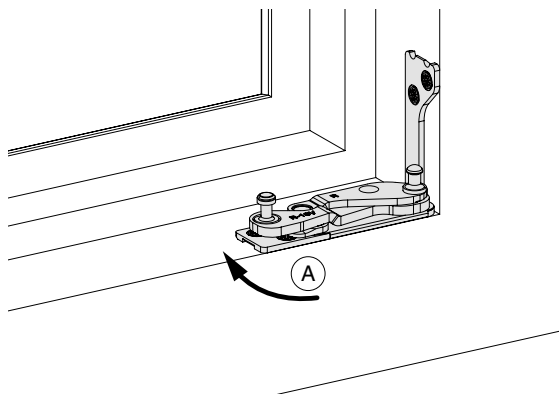

1. Close the pivot post (A).

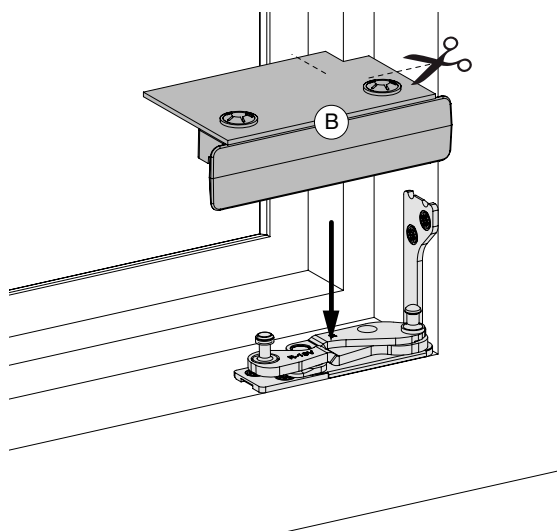

2. Cut the assembly cover (B) Article No. 218175 to size and press onto the two pivot post pins until it snaps in.

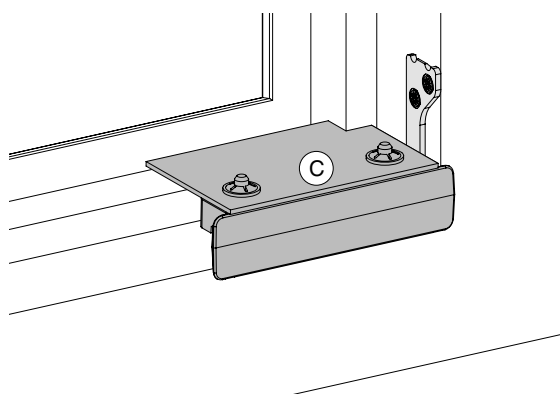

3. Assembly cover (C) in the assembled state.

## Hardware overview 1-sash tilt elements with fixed tilt-only hinge



### DANGER!

Use of a restrictor and cleaning stay is defined under FPKF Guidelines (quality association for locks and hardware - [www.schlossindustrie.de](http://www.schlossindustrie.de))!



### ATTENTION!

Pay attention to maximum load capacity of restrictor and cleaning stays!

For central lock installation see assembly instructions for central lock Order No. 757212



- ① Tilt-only hinge faceplate fixed MULTI POWER
- ② Tilt-only hinge arm with hinge
- ③ Restrictor and cleaning stay  
For quantity and size of restrictor and cleaning stays, see AWD
- ④ Compression device  
1 Pc. 800 - 1600 mm, 2 Pcs. 1601 - 2400 mm  
Take note of profile manufacturer information!



≤ 2400 x 1200 mm

≥ 255 mm

≥ 310 mm

≥ 650 mm

## Hardware overview 1-sash tilt elements with variable length tilt-only hinge



### DANGER!

Use of a restrictor and cleaning stay is defined under FPKF Guidelines (quality association for locks and hardware - [www.schlossindustrie.de](http://www.schlossindustrie.de))!



### ATTENTION!

Pay attention to maximum load capacity of restrictor and cleaning stays!

For central lock installation see assembly instructions for central lock Order No. 757212

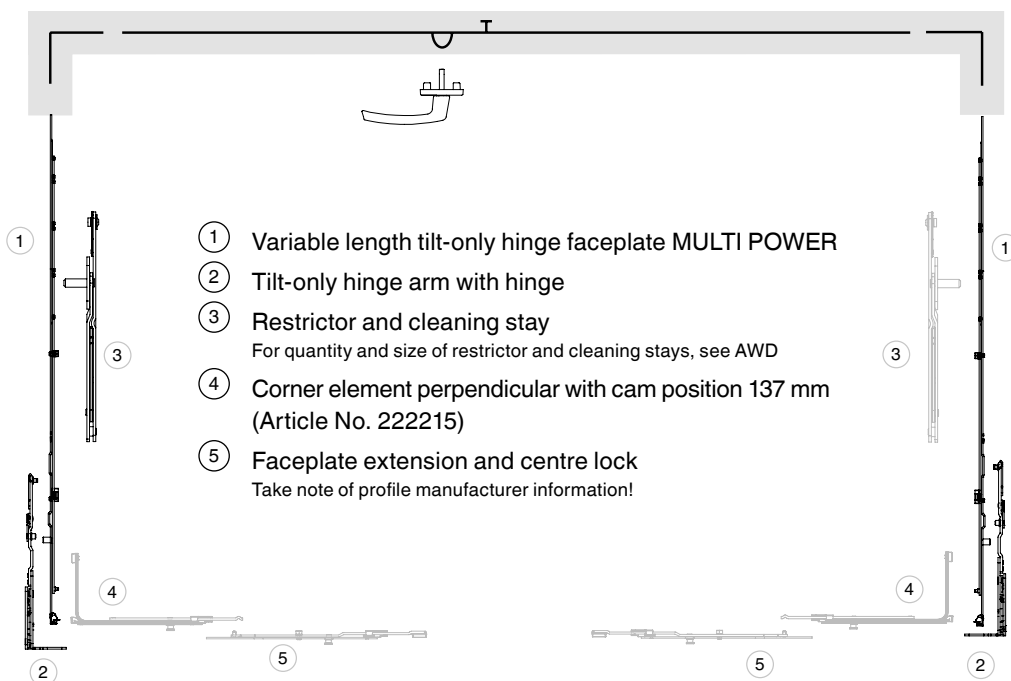

≤ 2400 x 1200 mm

≥ 455 mm

≥ 310 mm

≥ 650 mm

## Application diagram for tilt elements

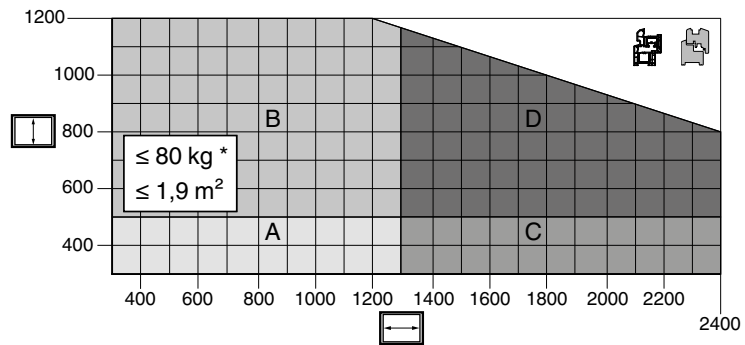

- |          |  |  |  |
|----------|--|--|--|
| <b>A</b> | 1 tilt stay + restrictor and cleaning stays Size. 1  | <b>D</b>   | 2 tilt stays + restrictor and cleaning stays Size. 2 |
| <b>B</b> | 1 tilt stay + restrictor and cleaning stays Size. 2  |  | Improper Area  |
| <b>C</b> | 2 tilt stays + restrictor and cleaning stays Size. 1 |  |  |

\* Use of a restrictor and cleaning stay is mandatorily defined (FPKF Guidelines at [www.schlossindustrie.de](http://www.schlossindustrie.de))! Pay attention to application diagram and maximum weight of restrictor and cleaning stays!

All notes on the use of application diagrams in our print and online catalogues must be considered!

Hardware installation on the frame  
Drilling with jig - tilt-only hinge FT24

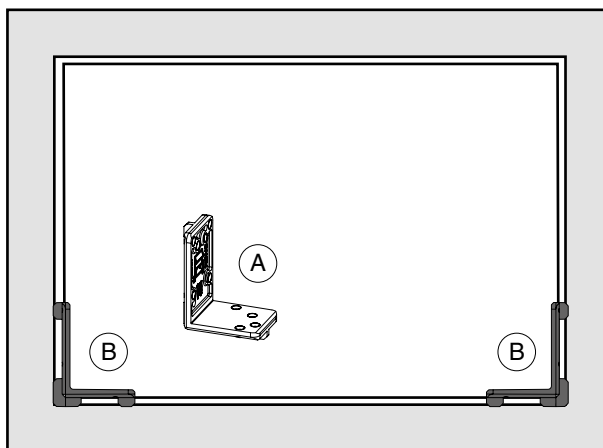

Insert drilling jig (A) for right sash (Article No. 217092) and left sash (Article No. 217093) in frame rebate corners (B) and pre-drill with  $\varnothing$  3 mm drill.

**Drill images tilt-only bearing FT24**

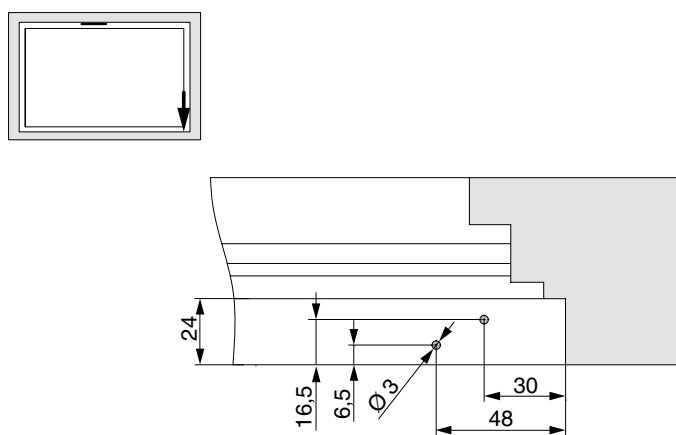
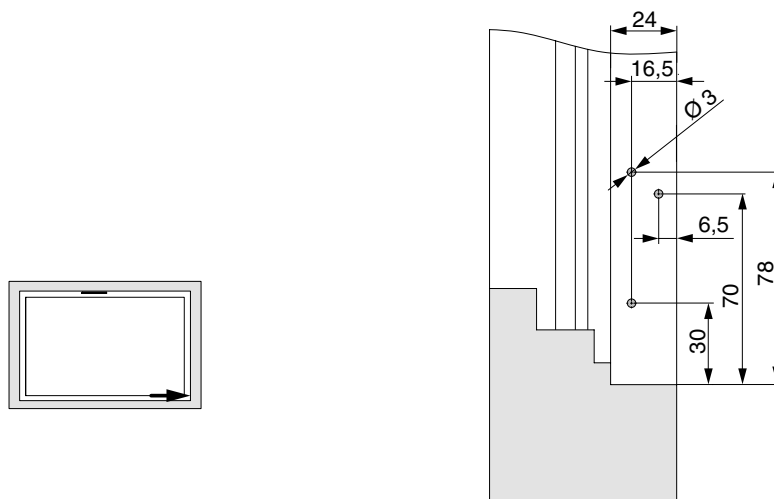

Hardware installation on the frame  
Drilling with jig - tilt-only bearing FT30

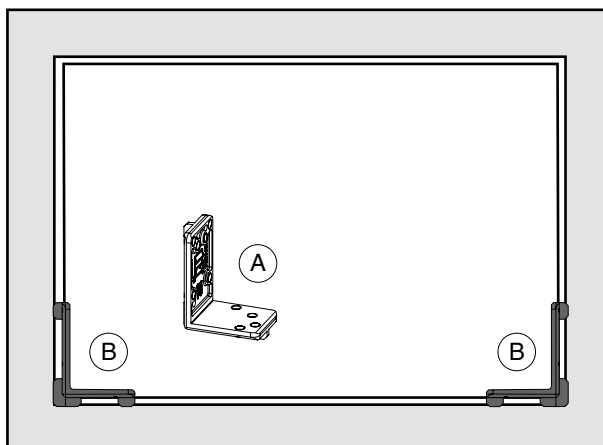

Insert drilling jig (A) for right tilt-only bearing or left tilt-only bearing (Article No. 217094) in frame rebate corners (B) and pre-drill with  $\varnothing$  3 mm drill.

**Drill images tilt-only bearing FT30**

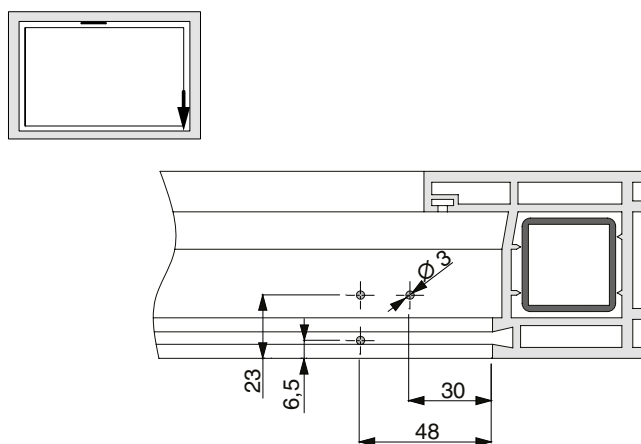
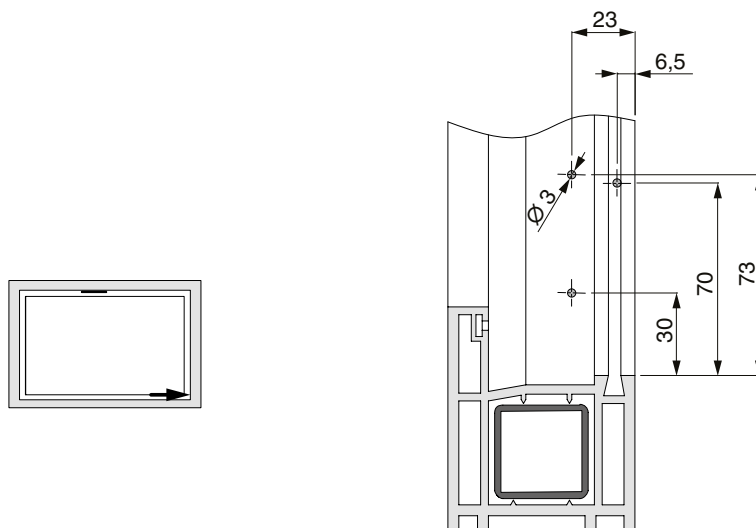

## Assembly of tilt-only hinge arm with hinge



### WARNING!

Use profile specific packers for PVC and aluminum profiles according to the profile sheet!



### DANGER!

The fixing with screws must be done in the steel reinforcement.

For profiles without steel reinforcement, see profile sheets or packing slip 756991!



### DANGER!

The fixing of the bearing parts must meet the requirements of the TBDK guidelines (quality association for locks and hardware - [www.schlossindustrie.de](http://www.schlossindustrie.de)) or comply with EN 13126-8!

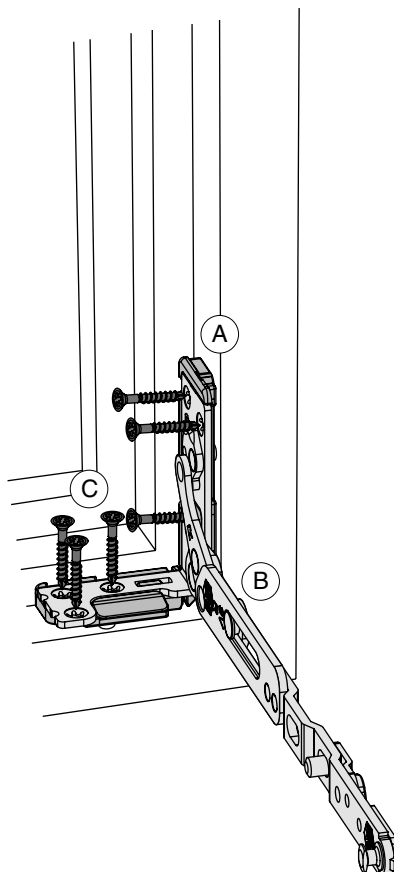

1. Insert the packer (A) on the baseplate (only for PVC and Aluminium).
2. Insert tilt-only bearing (B) opened in frame rebate corner and fix using special screw  $\varnothing 4.5 \times 38 \text{ mm}$  (C) (Article No. 362918 and 367828)!

The sash profile must be stabilised where necessary, e.g. with gluing. This applies above all to wide and high tilt-only sashes.

## 2-sash elements (French window elements)

### Hardware overview

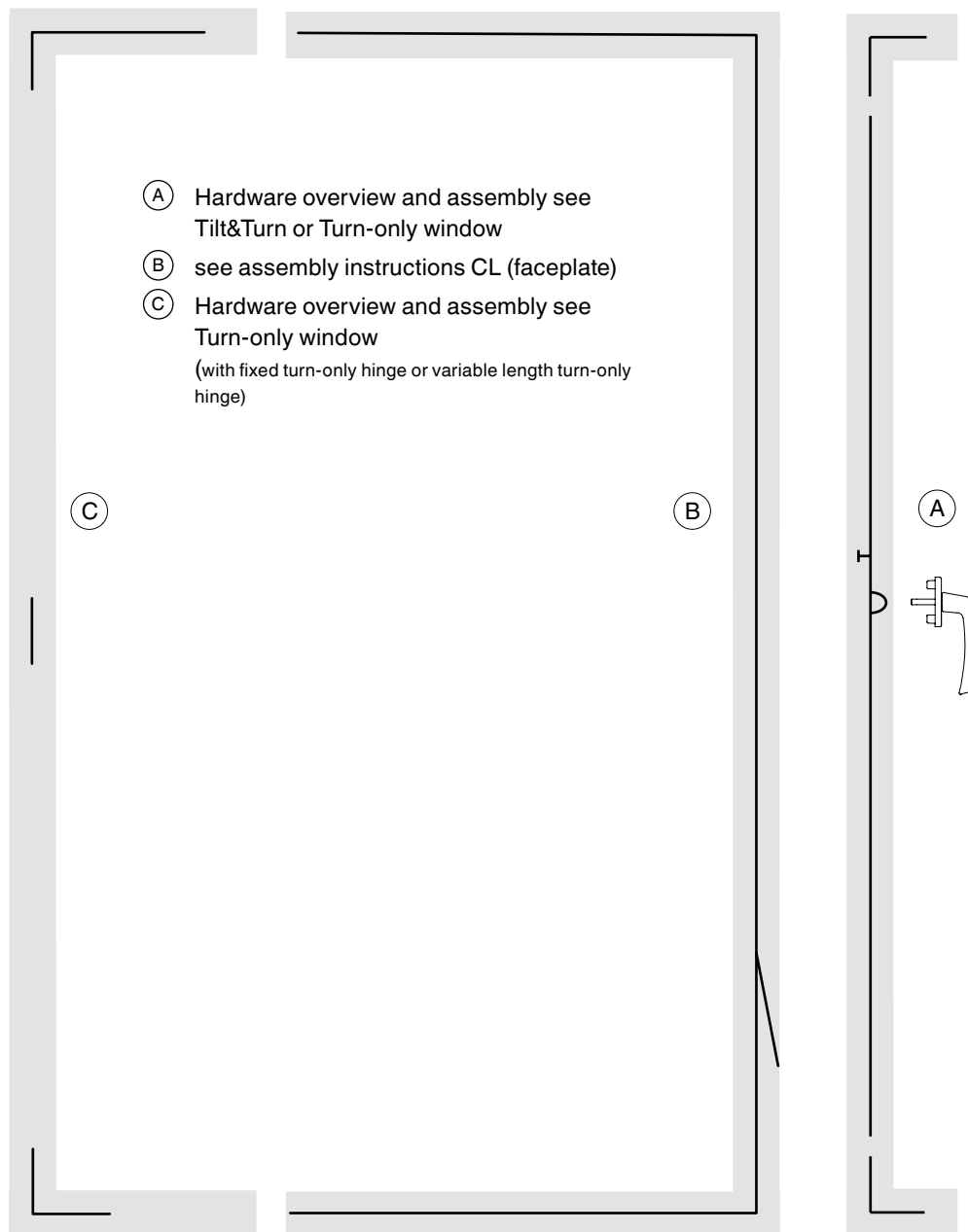









- Ⓐ Hardware overview and assembly see Tilt&Turn or Turn-only window
- Ⓑ see assembly instructions CL (faceplate)
- Ⓒ Hardware overview and assembly see Turn-only window  
(with fixed turn-only hinge or variable length turn-only hinge)





 ≤ 1650 x 2800 mm





 ≥ 465 mm

 ≥ 370 mm

 ≥ 360 mm (  15 )  
 ≥ 455 mm (  6,5 )

 ≥ 470 mm (  15 )  
 ≥ 530 mm (  6,5 )

 ≥ 270 mm (  15 )  
 ≥ 365 mm (  6,5 )

 ≥ 400 mm (  15 )  
 ≥ 460 mm (  6,5 )

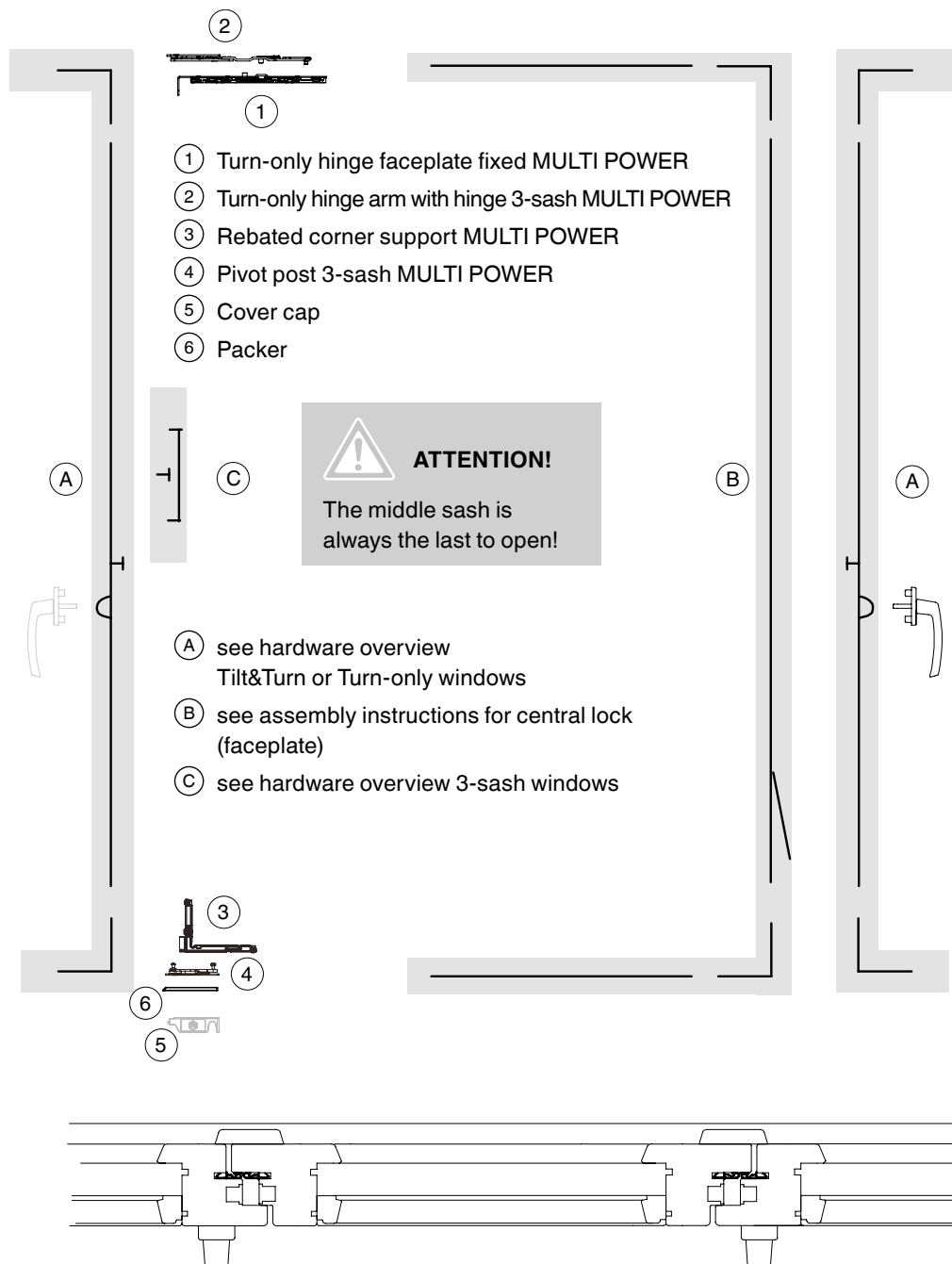

## 3-sash elements

Hardware overview turn-only elements with fixed turn-only hinge





 ≤ 1400 x 2600 mm

 ≥ 370 mm

 ≥ 360 mm (  15 )  
 ≥ 455 mm (  6,5 )

 ≥ 260 mm

 ≥ 470 mm (  15 )  
 ≥ 530 mm (  6,5 )

## 3-sash elements

Hardware overview turn-only elements with variable length turn-only hinge

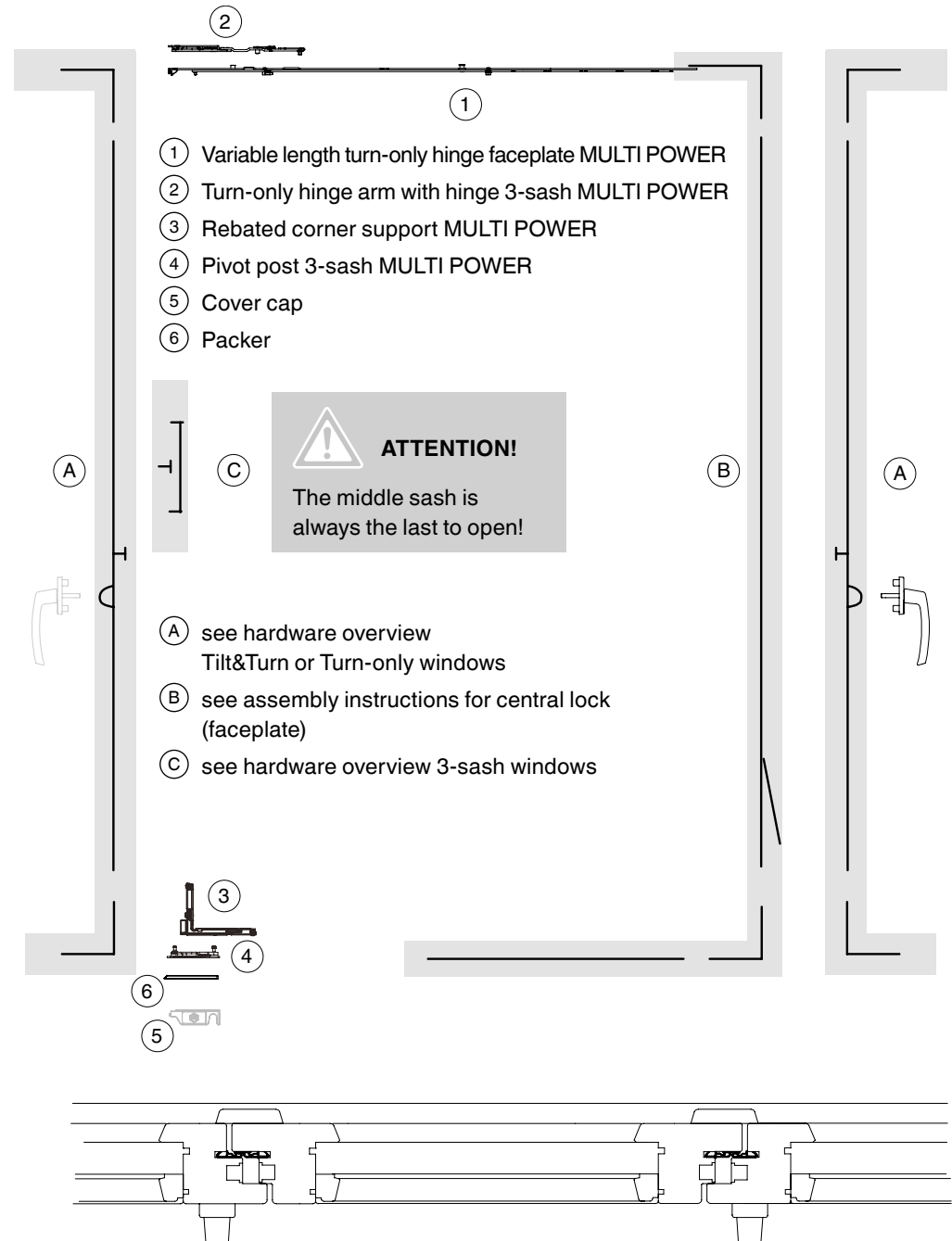

≤ 1400 x 2600 mm

≥ 401 mm

≥ 360 mm (15)  
 ≥ 455 mm (6,5)

≥ 320 mm

≥ 470 mm (15)  
 ≥ 530 mm (6,5)

## 3-sash elements

Hardware overview turn-only elements with operation lock

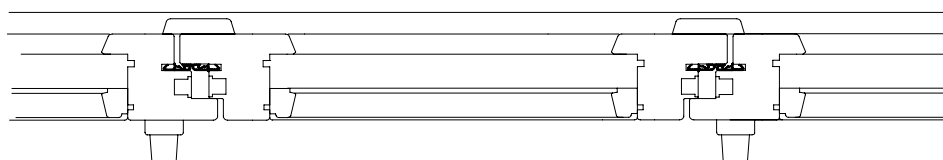
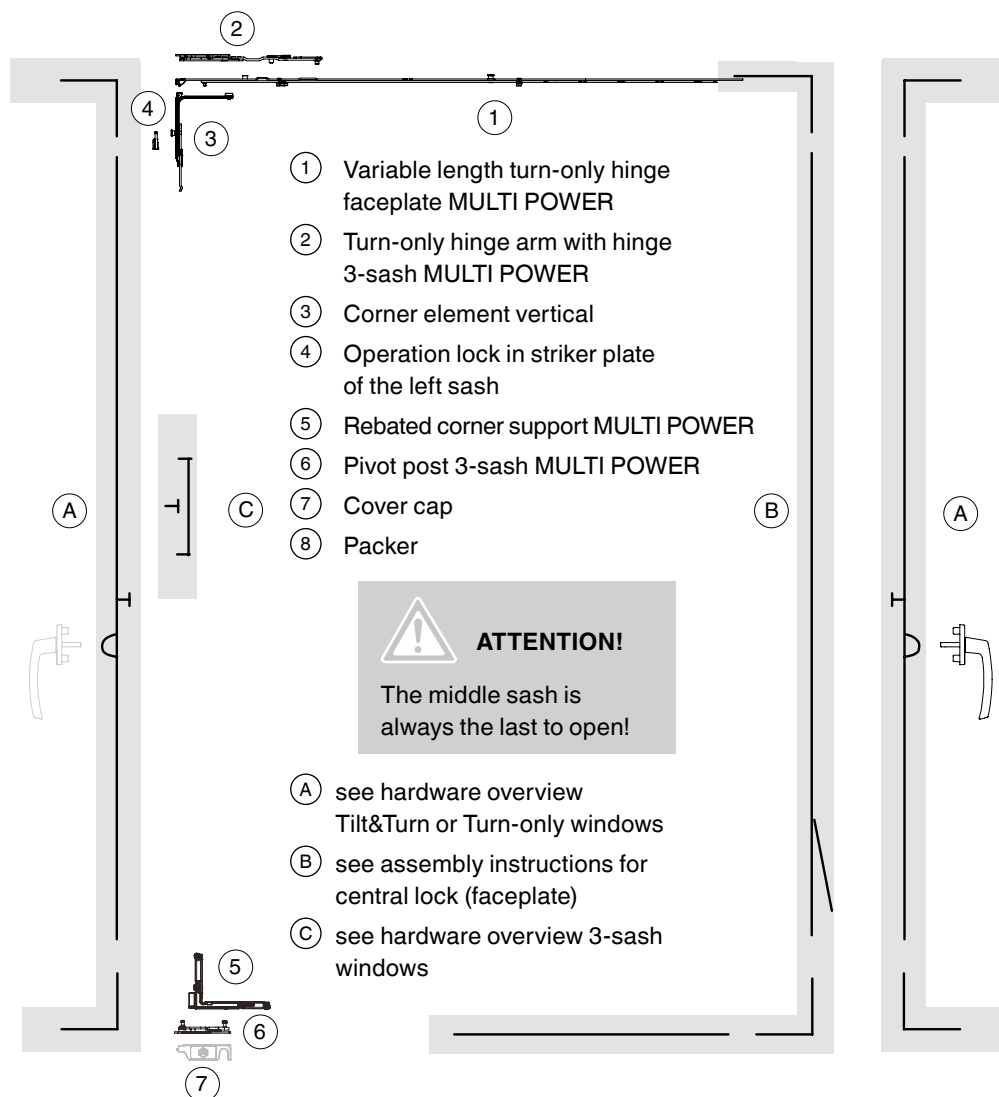

≤ 1400 x 2600 mm

≥ 401 mm





≥ 360 mm (↑ 15)  
≥ 455 mm (↓ 6,5)

≥ 320 mm

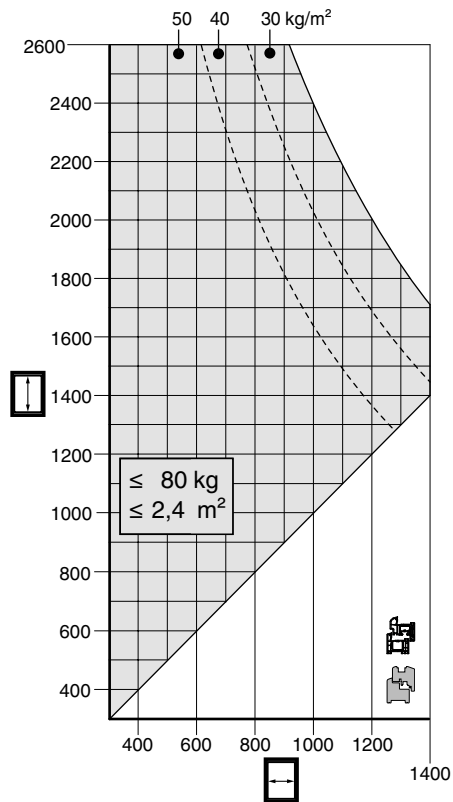
≥ 470 mm (↑ 15)  
≥ 530 mm (↓ 6,5)

### Application diagram for 3-sash Turn-only element



-  Permissible area
-  Stabilising scissor stay required
-  Improper Area
-  for PVC profiles
-  for timber profiles

All notes on the use of application diagrams in our print and online catalogues must be considered!

## Hardware installation on the frame

### Drilling with jig for pivot post and turn-only hinge 3-sash window for timber FT24

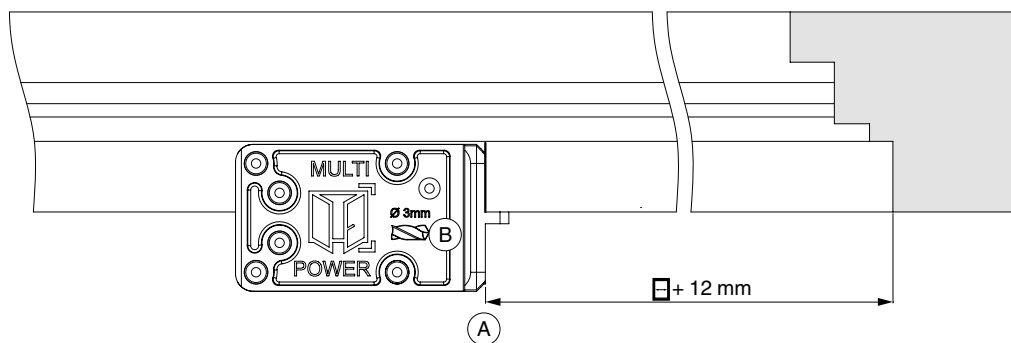

1. Mark the sash rebate size + 12 mm (rebate gap) on the frame (A).
2. Position drilling jig (B) for right sash (Article No. 217092) and left sash (Article No. 217093) on markings and pre-drill with  $\varnothing 3$  mm drill.

### Drilling image pivot post and turn-only hinge 3-sash window FT24



#### WARNING!

Frame must be underpinned and anchored in the wall when assembling the 3-sash hinge area!

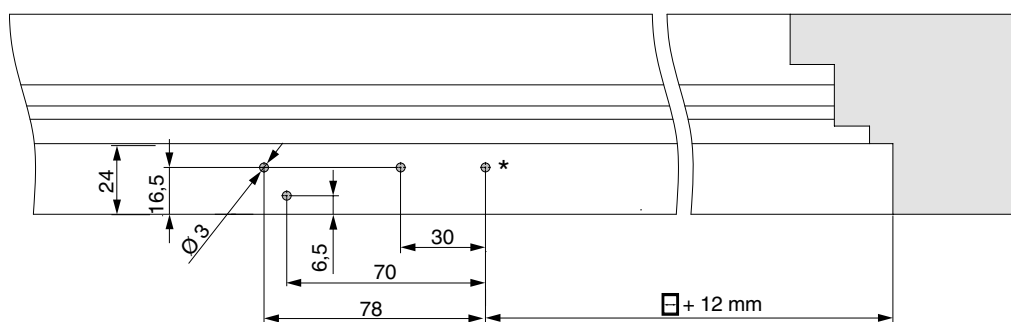

\* After inserting the hinge, drill and screw fix the missing screw hole.

### Drilling with jig for pivot post and turn-only hinge 3-sash window for timber and PVC FT30

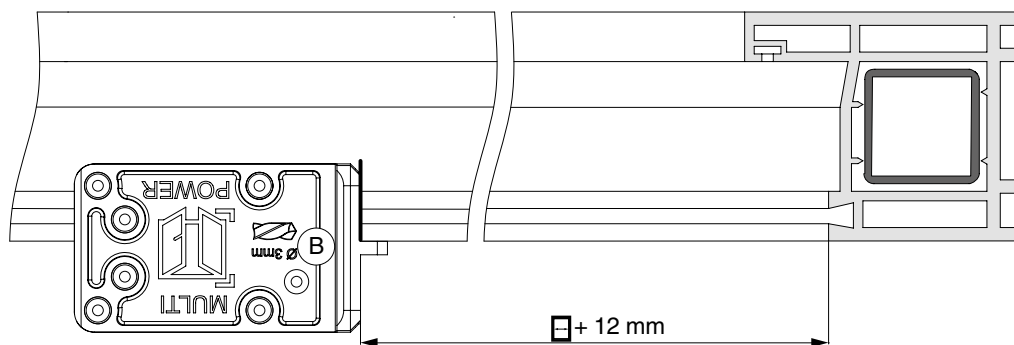

#### WARNING!

Frame must be underpinned and anchored in the wall when assembling the 3-sash hinge area!

1. Mark the sash rebate size + 12 mm (rebate gap) on the frame (A).
2. Position drilling jig (B) for right sash and left sash (Article No. 217093) on markings and pre-drill with  $\varnothing 3$  mm drill.

### Drilling image pivot post and turn-only hinge 3-sash window FT30

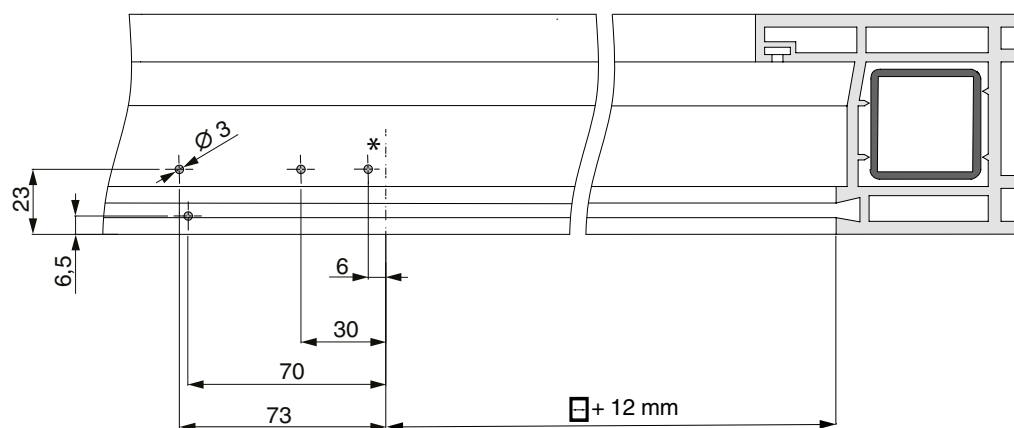

#### DANGER!

The fixing with screws must be done in the steel reinforcement. For profiles without steel reinforcement, see profile sheets or packing slip 756991!

\* After inserting the hinge, drill and screw fix the missing screw hole.

### Milling the frame on 3-sash windows under FT24 - turn-only hinge

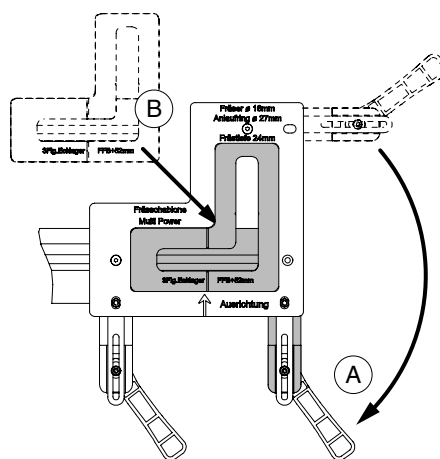

1. Reassemble the clamp handle (A) so that both handles are located on the alignment side.
2. Insert the routing jig (B) Article No. 368094 (with lettering upwards) in the routing jig.

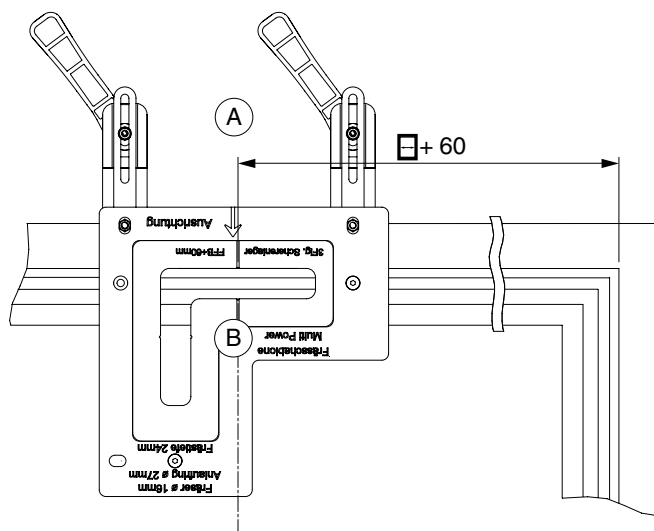

1. Mark the sash rebate size + 60 mm on the frame (A).
2. Align the routing jig (B) with the cap marking, clamp the routing jig in place and mill with  $\varnothing 16$  mm cutter and  $\varnothing 27$  mm copy ring.

### Routing diagram 3-sash window FT24

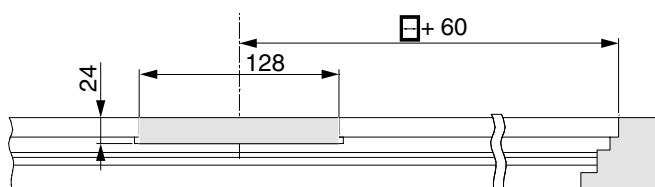

### Milling the frame on 3-sash windows under FT24 - pivot post

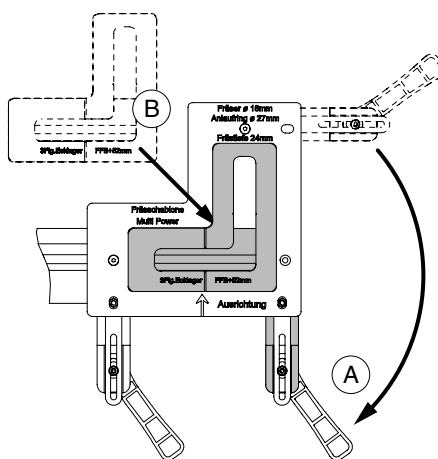

1. Reassemble the clamp handle (A) so that both handles are located on the alignment side.
2. Insert the routing jig (B) Article No. 368094 (with lettering upwards) in the routing jig.

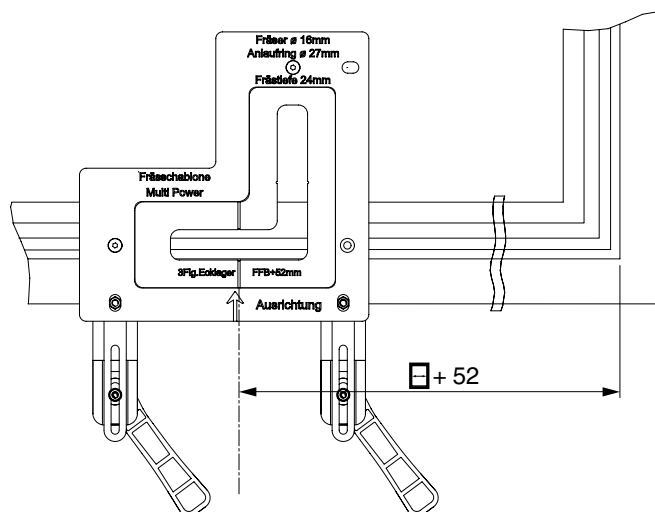

1. Mark the sash rebate size + 52 mm on the frame (A).
2. Align the routing jig (B) with the cap marking, clamp the routing jig in place and mill with  $\text{Ø } 16 \text{ mm}$  cutter and  $\text{Ø } 27 \text{ mm}$  copy ring.

### Routing diagram pivot post 3-sash window FT24

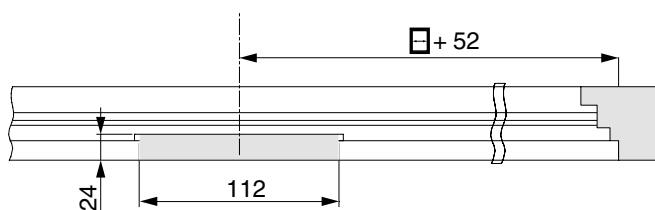

## Free dimensions

### Flush profiles, 3-sash

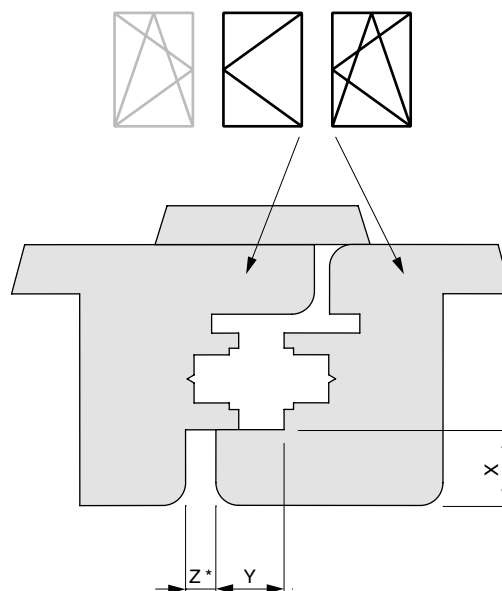

#### CAUTION!

The minimum free size depends on the version of the rebate leg (radius, varnish thickness...). The values for Z in the table are without taking tolerances into account. We always recommend a customer-side check of the used profile in advance!

#### Values for Z

		X								
		16	17	18	19	20	21	22	23	24
Y	18Ü	4	4	4	6	7	8	9	10	12
	20Ü	4	4	4	4	5	6	7	8	10
	22Ü	4	4	4	4	4	5	6	7	8

## Assembly of 3-sash pivot post and 3-sash scissor stay arm with hinge



### DANGER!

The fixing with screws must be done in the steel reinforcement.  
For profiles without steel reinforcement, see profile sheets or packing slip 756991!



### DANGER!

The fixing of the bearing parts must meet the requirements of the TBDK guidelines (quality association for locks and hardware - [www.schlossindustrie.de](http://www.schlossindustrie.de)) or comply with EN 13126-8!



### WARNING!

Use profile specific packers for PVC and aluminum profiles according to the profile sheet!



### WARNING!

With timber, the pivot post must rest on the entire surface!  
Glue grooves (Euro-groove, groove for frame gasket).

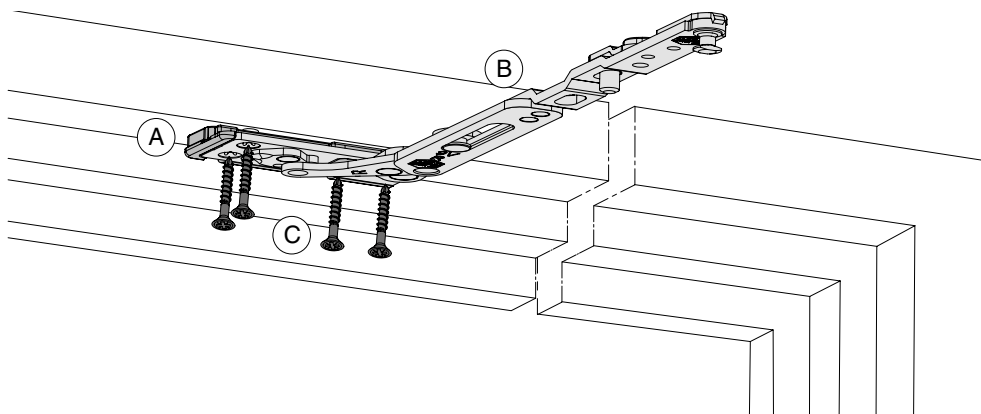

1. Insert the packer (A) on the baseplate (only for PVC and Aluminium).
2. Insert scissor stay arm with hinge (B) opened in frame rebate corner and fix using special screw  $\varnothing 4.5 \times 38 \text{ mm}$  (C) (Article No. 362918 and 367828)!

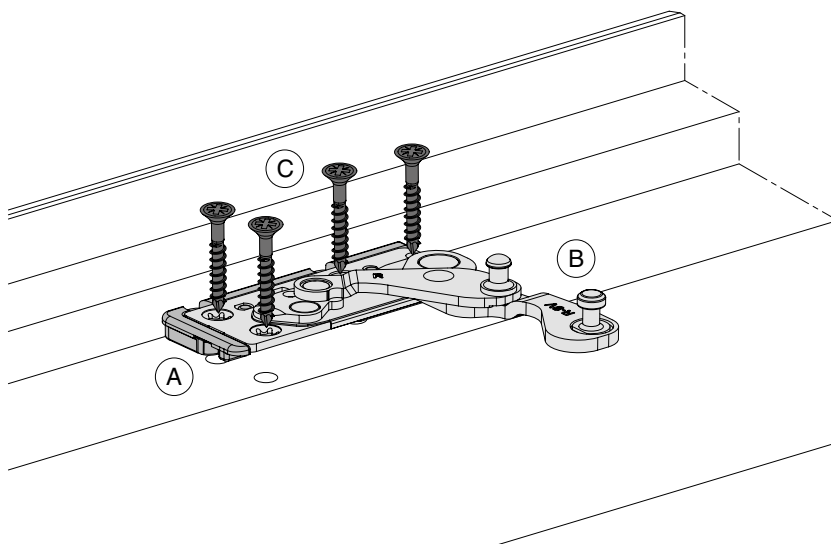

1. Insert the packer (A) on the baseplate (only for PVC and Aluminium).
2. Insert pivot post (B) opened in frame rebate corner and fix with special screw  $\varnothing 4,5 \times 38 \text{ mm}$  (C) (Article No. 362918 and 367828)!

## Accessories, Special Solutions

### Cover cap assembly

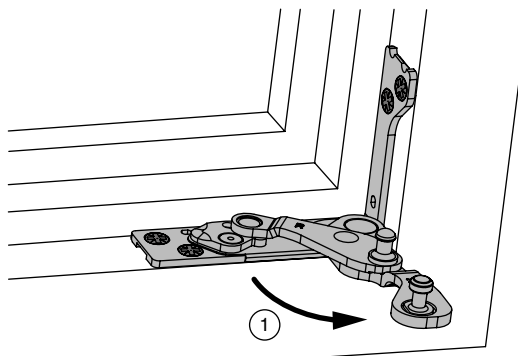

① Open pivot post.

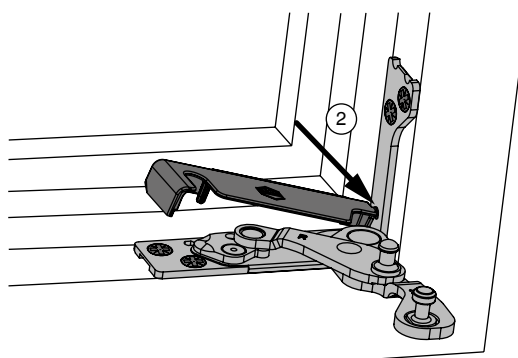

② Hang the cover cap into the corner area.

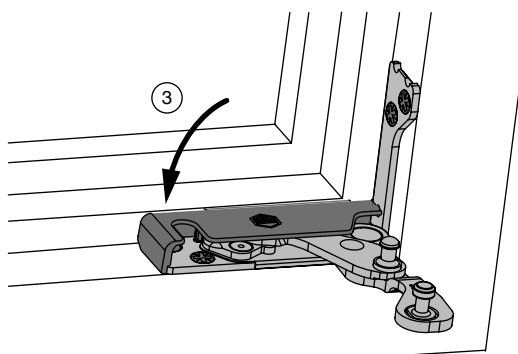

③ Clip the cover cap into the baseplate.

## MULTI POWER with load-bearing



### DANGER!

From 150 kg sash weight, use load transfer device!  
Basic setting of the load transfer device = 180 kg!



### DANGER!

To support the pivot post in timber with sash weights from 100 kg, use the support rawplug Article No. 36668!

### 1 Window design

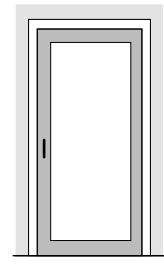
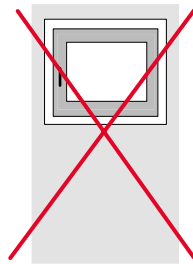
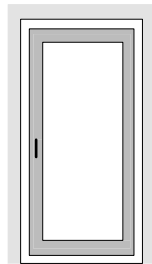

\* see assembly instructions MULTI POWER in floor thresholds (Order No. 758590)

### 2 Opening types

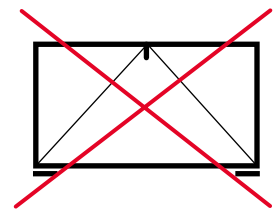
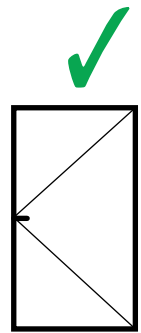
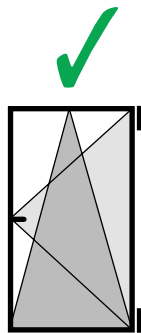
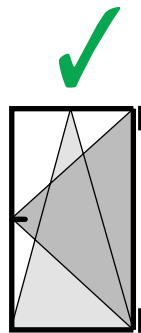

Opening width  $\leq 100^\circ$

### 3 Application areas

$\leq 1300 \times 2800$  mm

$\geq 465$  mm

$\geq 370$  mm

$\geq 360$  mm ( 15 )  
 $\geq 455$  mm ( 6,5 )

$\geq 470$  mm ( 15 )  
 $\geq 530$  mm ( 6,5 )

$\geq 270$  mm ( 15 )  
 $\geq 365$  mm ( 6,5 )

$\geq 400$  mm ( 15 )  
 $\geq 460$  mm ( 6,5 )

## Hardware overview MULTI POWER with load-bearing



### DANGER!

From 150 kg sash weight,  
use load transfer device!  
Basic setting of the load  
transfer device = 180 kg!



### DANGER!



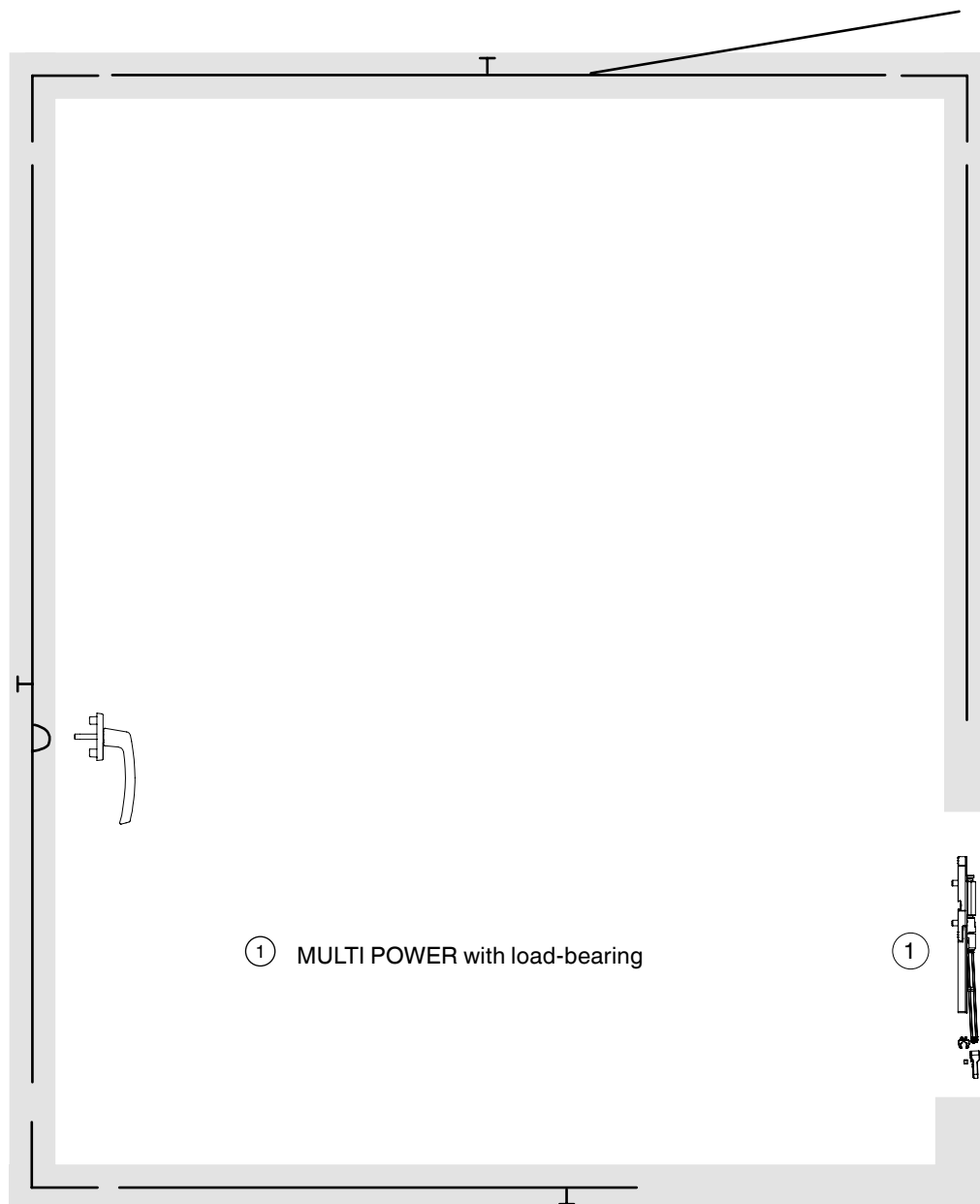

To support the pivot  
post in timber with sash  
weights from 100 kg, use  
the support rawlplug  
Article No. 36668!

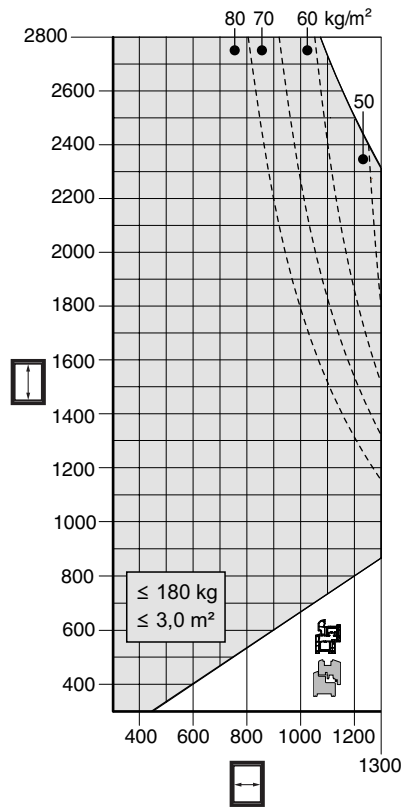

Central lock see page 11 ff.

**Application diagram for turn-only and tilt&turn elements with load transfer device**



-  Permissible area
-  Stabilising scissor stay required
-  Improper Area
-  for PVC profiles
-  for timber profiles

All notes on the use of application diagrams in our print and online catalogues must be considered!

### Assembly of the seal



#### WARNING!

It is mandatory to use a seal!

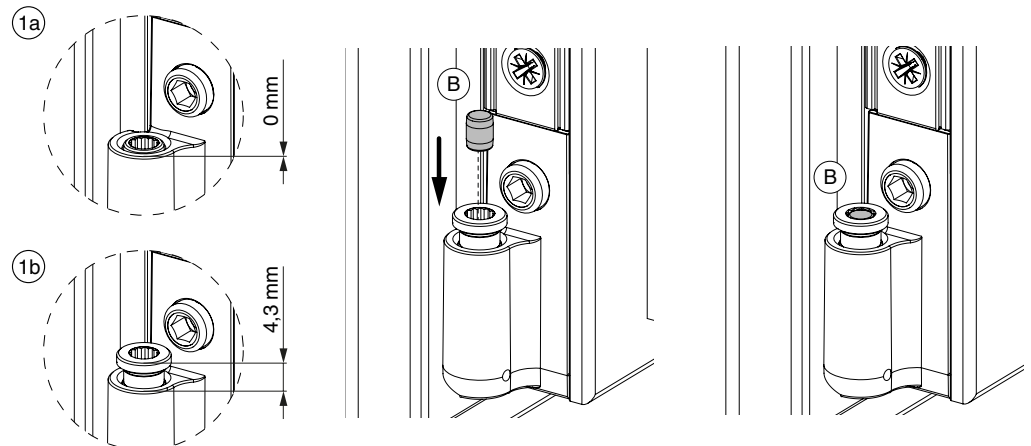

1. The height adjustment screw on the corner support must be in the “Neutral Position” (default delivery status - representation for both versions).  
**Especially IMPORTANT for retrofits!**
2. Squeeze the seal (B) completely into the screw for height adjustment.

### Drilling with jig

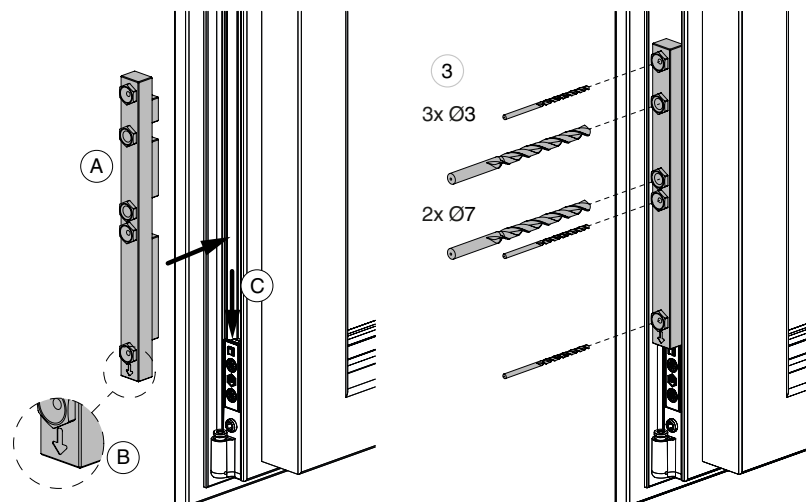

1. Position the routing jig (A) Article No. 228518 exactly (B) arrow pointing downwards) in the fitting groove.
2. Push the jig down (C) until it hits the corner support.
3. Pre-drill with Ø 3 mm or Ø 7 mm drill.

### Assembly of sash component load transfer device

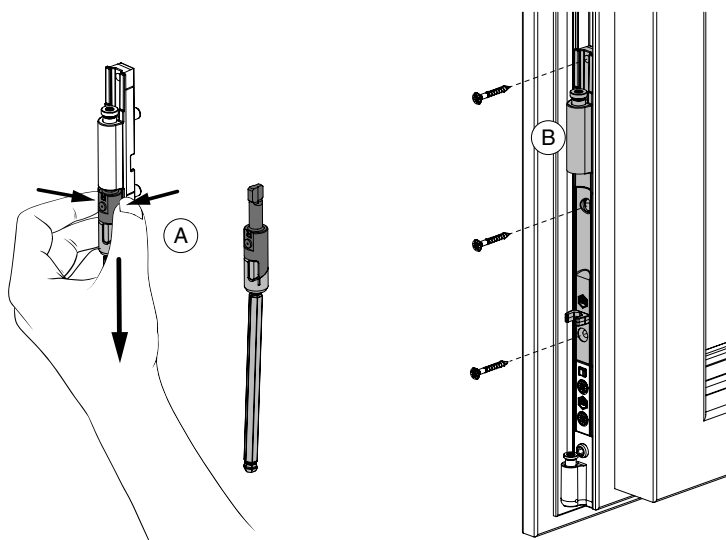

1. Grab the spindle unit at the top (A) and pull it out.
2. Place the sash load transfer device (B) in the fitting groove and screw in.

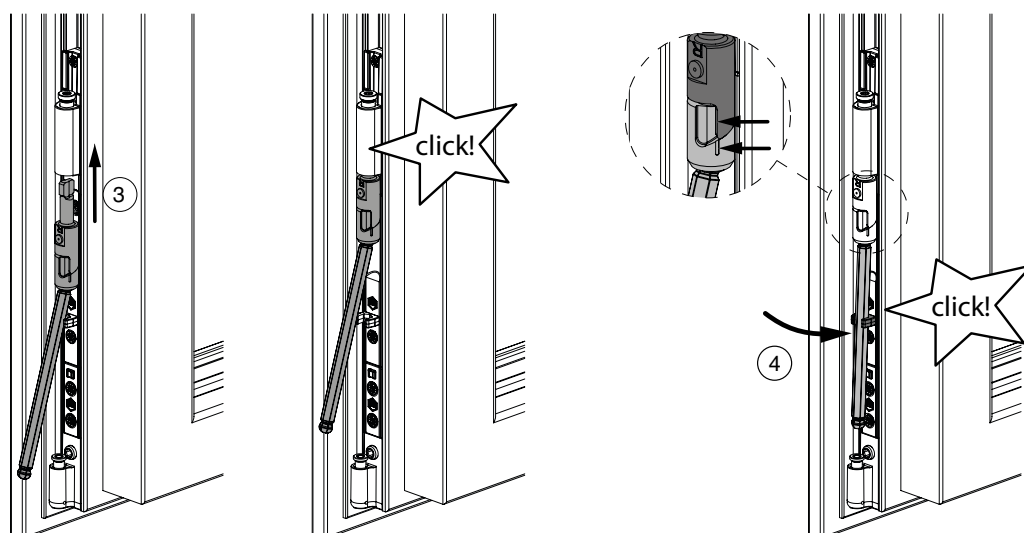

3. Position the spindle unit exactly and push upwards (3) until it "clicks."
4. Clip in the hexagonal spindle unit in the installation aid (4).

**Retain leftover central fixings and installation aid for later use!**

## Support rawplug assembly



### DANGER!

The fixing of the bearing parts must meet the requirements of the TBDK guidelines (quality association for locks and hardware - [www.schlossindustrie.de](http://www.schlossindustrie.de))

FT24

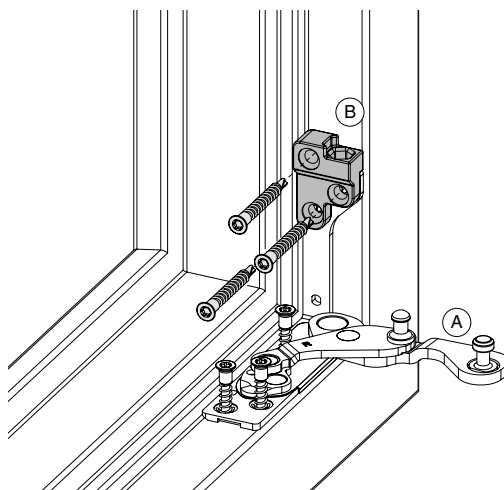

FT30

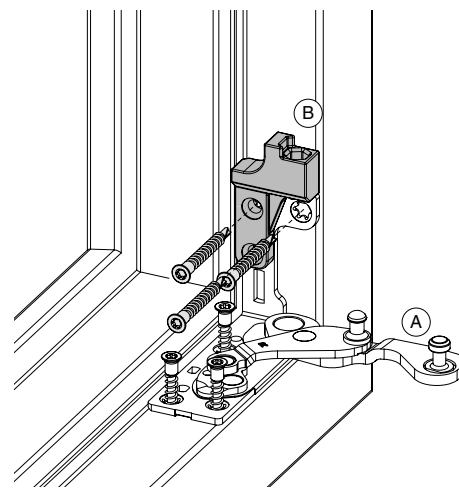

1. Fix the pivot post (A) horizontally.
2. Position the support rawplug (B) over the vertical part of the pivot post.
3. Screw in support rawplug and pivot post with special screw  $\varnothing 4.5 \times 38$  mm (Article No. 362918 and 367828).



### DANGER!

Use turn restrictor in timber!

### Installation of turn restrictors (timber only)

In timber, the use of a turn restrictor for MULTI POWER (Article No. 103623 or 103624) is required!

Install the turn restrictor according to the instruction leaflet (Order No. 750304).

## Drilling with the jig – Threshold support

FT24 / FT24/30

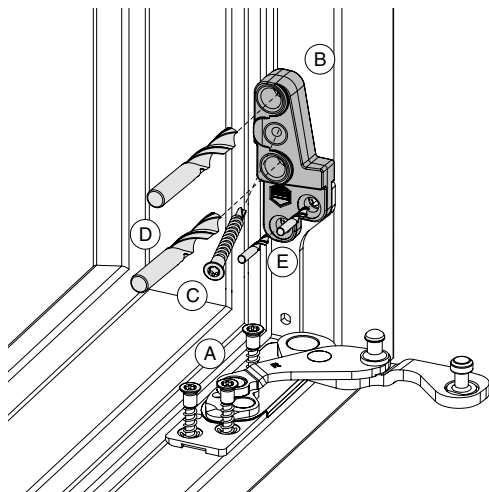

FT30

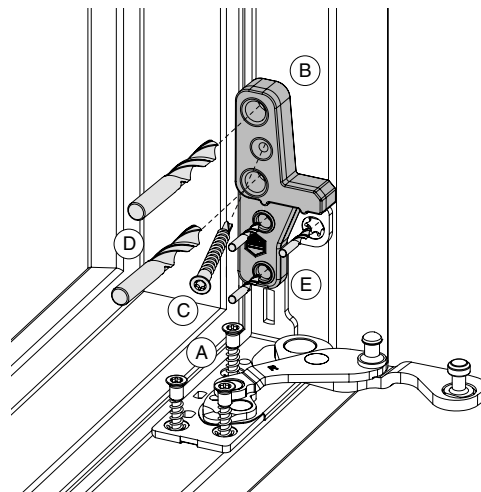

1. Screw-in the Pivot Post (A) horizontally.
2. Position the drilling jig (B) (Article No. 229835 - FT24, 229836 - FT24/30 or 229837 - FT30) above the vertical part of the pivot post and fix with screw (C).
3. Drill holes  $\varnothing 7$  mm with a minimum of 15 mm for the support pins (D). Pre-drill the screw holes  $\varnothing 3$  mm (E).
4. Unscrew screw (C) and remove drilling jig.

## Drilling Diagrams

FT24

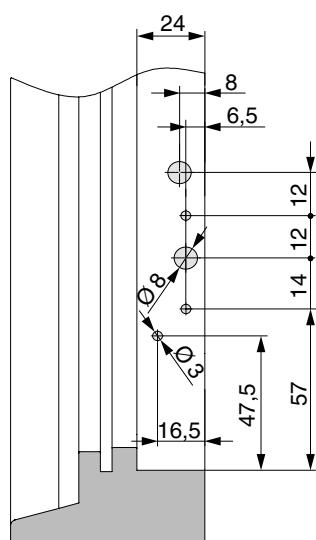

FT24/30

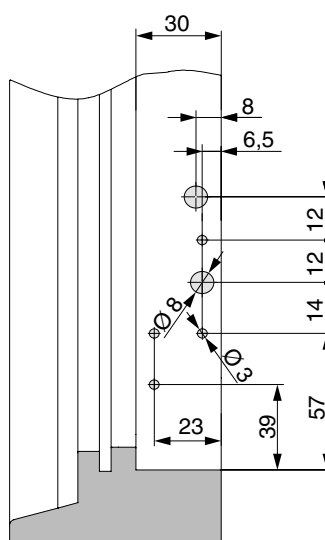

FT30

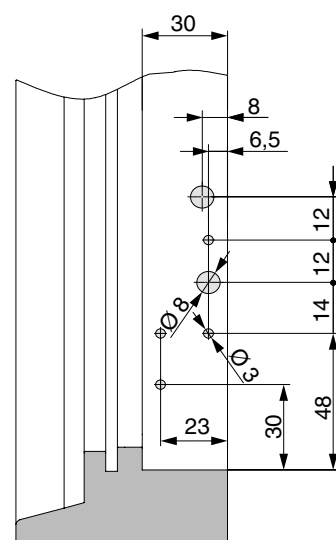

## Assembly of the threshold support

FT24 / FT24/30

FT30



### DANGER!

The fixing of the hinge parts must meet the requirements of the TBDK guidelines (Quality Association for Locks and Hardware - [www.schlossindustrie.de](http://www.schlossindustrie.de)) or the EN 13126-8 standard!

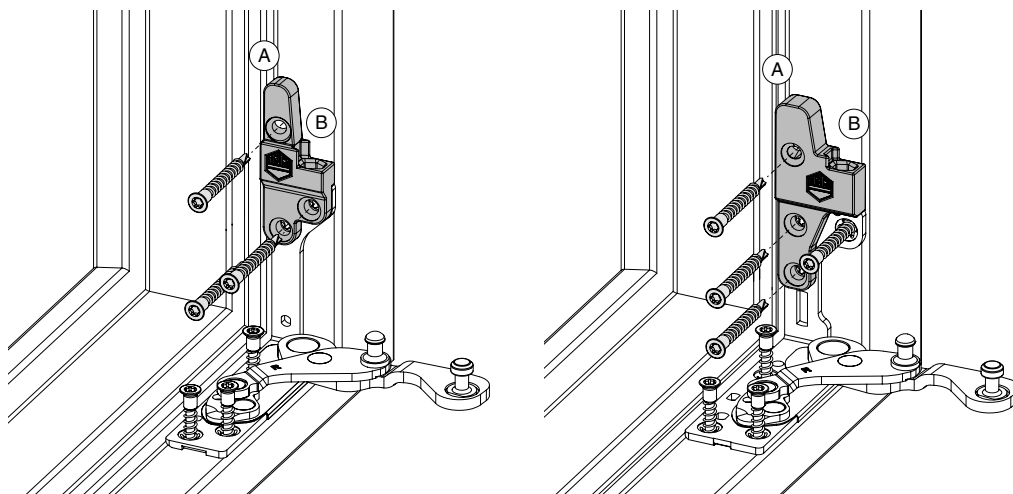

1. Add packer (A) (Article No. 372008 or 372009) to the support if required and fix the support (B) with the support pins in the drill holes.
2. Screw in support rawplug and pivot post with special screw  $\varnothing 4.5 \times 38 \text{ mm}$  (Article No. 362918 and 367828).



### DANGER!

Use turn restrictor in timber!

### Installation of turn restrictors (timber only)

In timber, the use of a turn restrictor for MULTI POWER (Article No. 103623 or 103624) is required!

Install the turn restrictor according to the instruction leaflet (Order No. 750304).

### Initial hinging of the sash into the frame

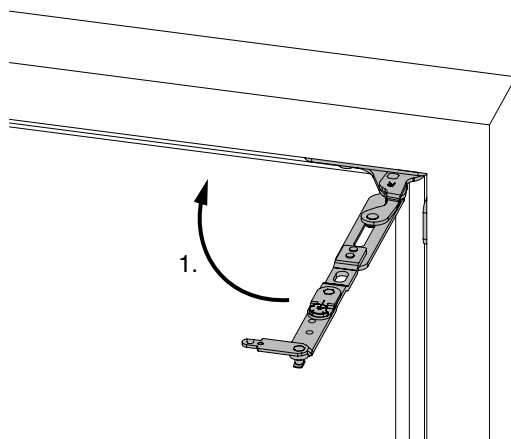

1. Swing the scissor arm with hinge into the frame.

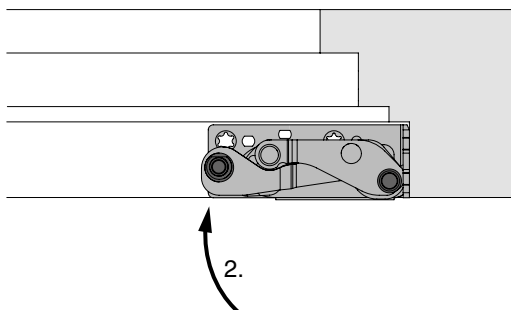

2. Close pivot post.



**DANGER!**

Pay attention to sash weight!

Sash weight must be held by a person until fully mounted!

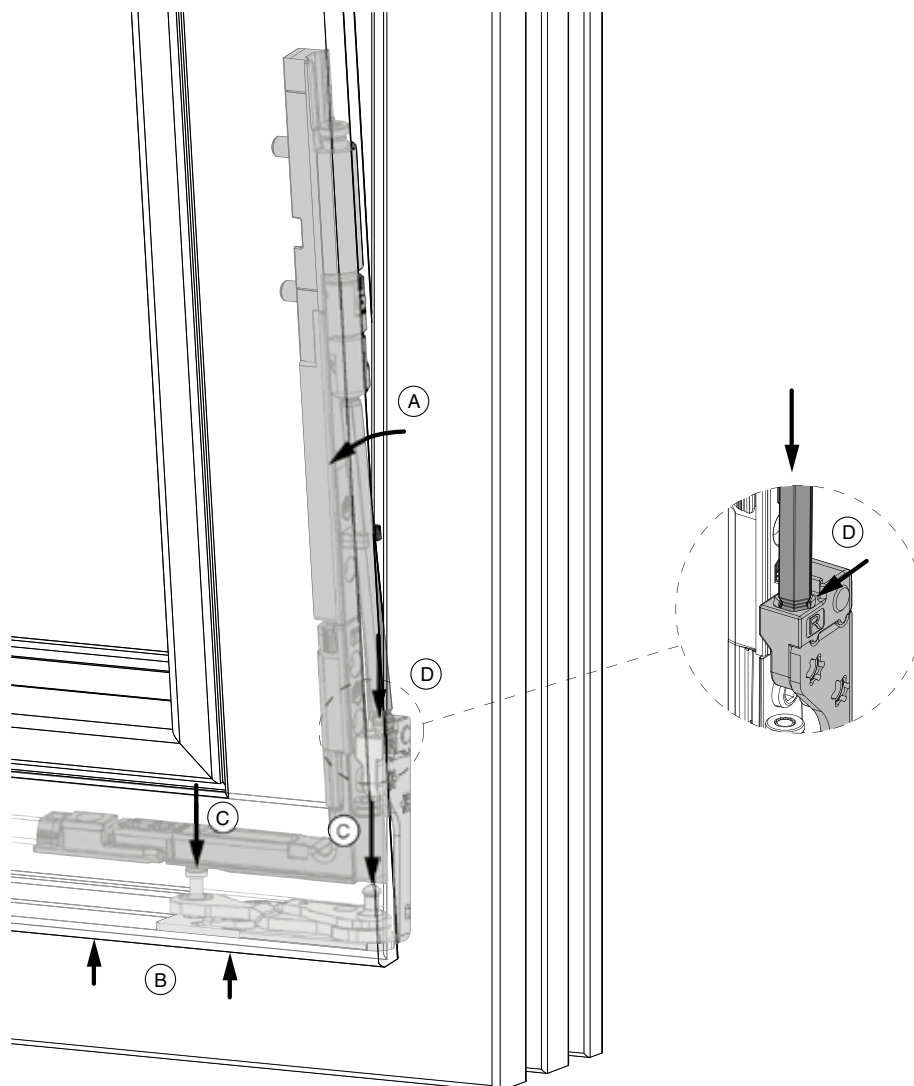

3. Insert the sash lightly tilted (A) and parallel to the frame (B) on both pivot post pins (C).  
The hexagonal spindle, fixed by the installation aid, must sit in the support (D).  
**The correct position of the hexagonal head in the support pan must be checked!**
4. Open the window sashes approx. 90° (centre fixing of load transfer device will be torn through) and connect the scissor stay arm with the hinge with scissor stay faceplate.

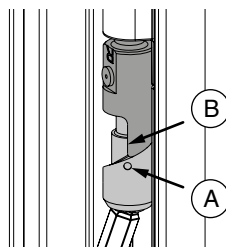

5. Check the position of the spindle. With 90° open sash, the marker point (A) must align with the edge (B).

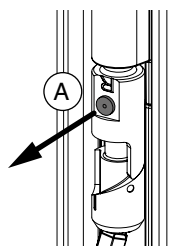

6. Remove visible part of the centre fixing (A). If centre fixing is missing, check the rebate area and pivot post and remove loose part.

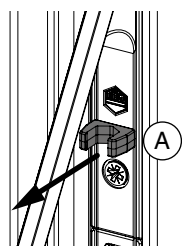

7. Remove installation aid (A).
8. Check the rebate gap at the bottom horizontally and, if necessary, adjust to 12.5 mm. For height settings see page 60.

### Hinging and unhinging of the sash in the frame (during later maintenance work)

(Centre fixing (Article No. 371632) and installation aid (Article No. 371447) from the load transfer device delivery are required!)

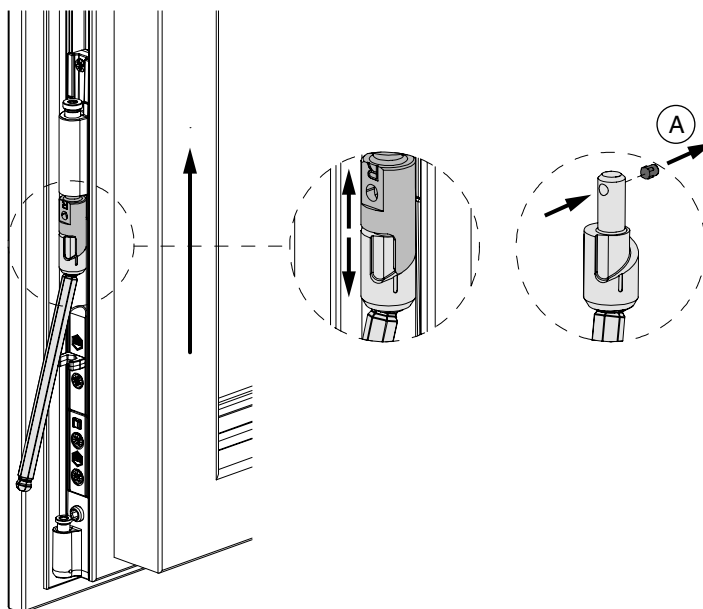

1. When unhinging the sash, the two spindle parts are separated! The centre fixing stop (A) must be removed from the upper spindle part!

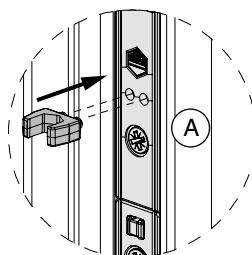

2. Insert installation aid (A).

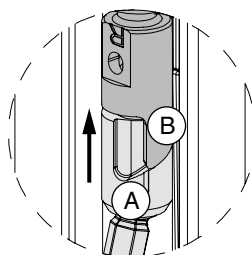

3. Check the position of the lower part of the spindle. The notch (A) must align with the edge (B). Insert the lower spindle part in the upper spindle part.

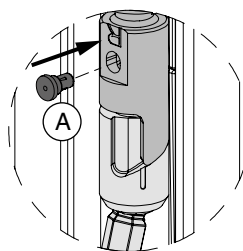

4. Insert the centre fixing (A) in the upper part of the spindle.

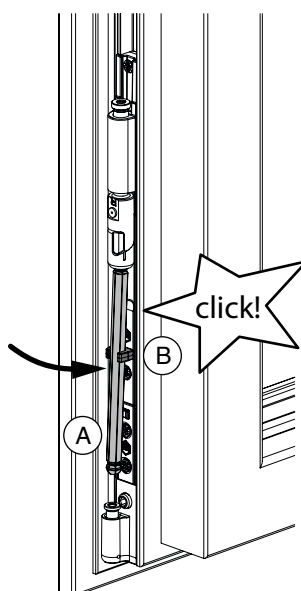

5. Clip in the hexagonal spindle unit (A) in the installation aid (B).
6. The hinging of the sash is performed according to the previous description (initial installation).

### Height adjustment for elements with MULTI POWER load transfer device



#### WARNING!

Adjust the height only on the load transfer device – not on the corner support!

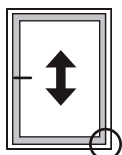

-1 / +2

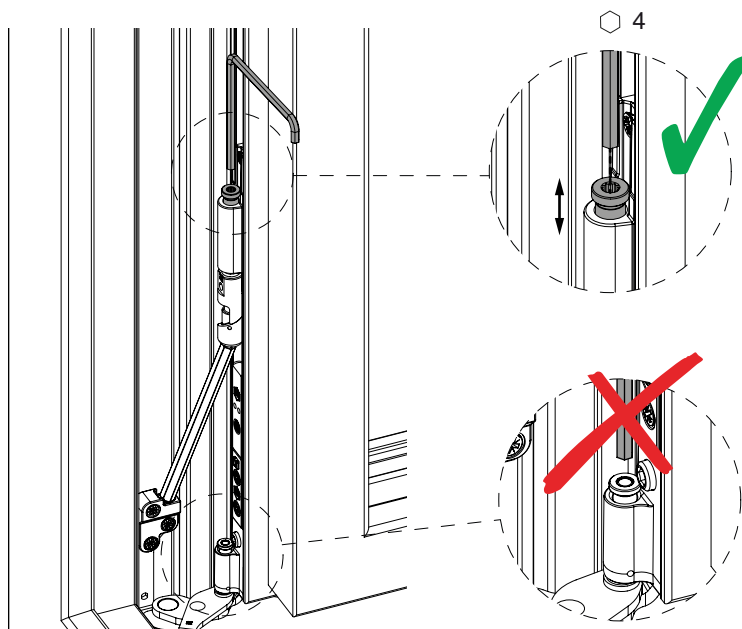

## MULTI POWER in slim frame profiles



### WARNING!

To support the pivot post in timber with sash weights from 100 kg, use the support rawplug Article No. 36668!



### WARNING!

From 100 kg sash weight, use Oak insert!

### 1 Applications / Sash design

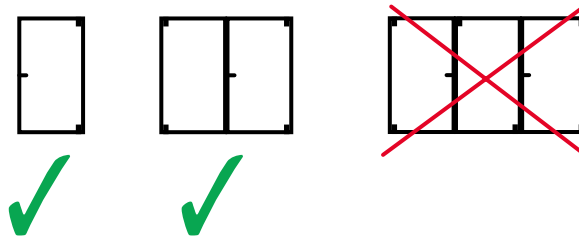

### 2 Opening types

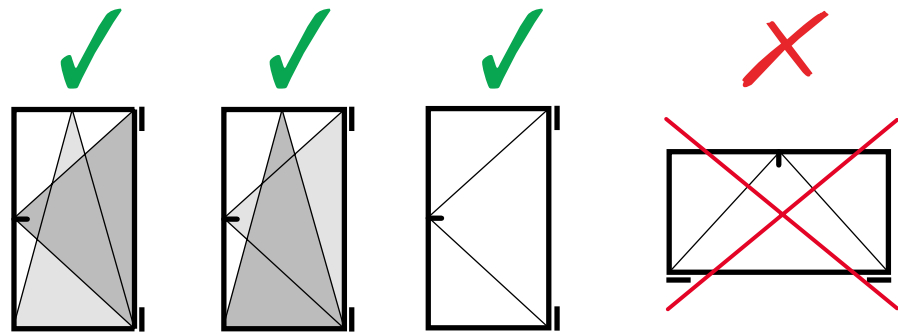

Opening width  $\leq 100^\circ$

### 3 Application areas

$\leq 1650 \times 2800$ mm		
$\geq 370$ mm	$\geq 360$ mm ( $\begin{matrix} \updownarrow \\ 15 \end{matrix}$ ) $\geq 455$ mm ( $\begin{matrix} \updownarrow \\ 6,5 \end{matrix}$ )	$\geq 270$ mm ( $\begin{matrix} \updownarrow \\ 15 \end{matrix}$ ) $\geq 365$ mm ( $\begin{matrix} \updownarrow \\ 6,5 \end{matrix}$ )
$\geq 260$ mm	$\geq 470$ mm ( $\begin{matrix} \updownarrow \\ 15 \end{matrix}$ ) $\geq 530$ mm ( $\begin{matrix} \updownarrow \\ 6,5 \end{matrix}$ )	$\geq 400$ mm ( $\begin{matrix} \updownarrow \\ 15 \end{matrix}$ ) $\geq 460$ mm ( $\begin{matrix} \updownarrow \\ 6,5 \end{matrix}$ )

Hardware overview of Turn&Tilt, Tilt&Turn and Turn-only see page 11 ff.

**Application diagram MULTI POWER in slim frame profiles**

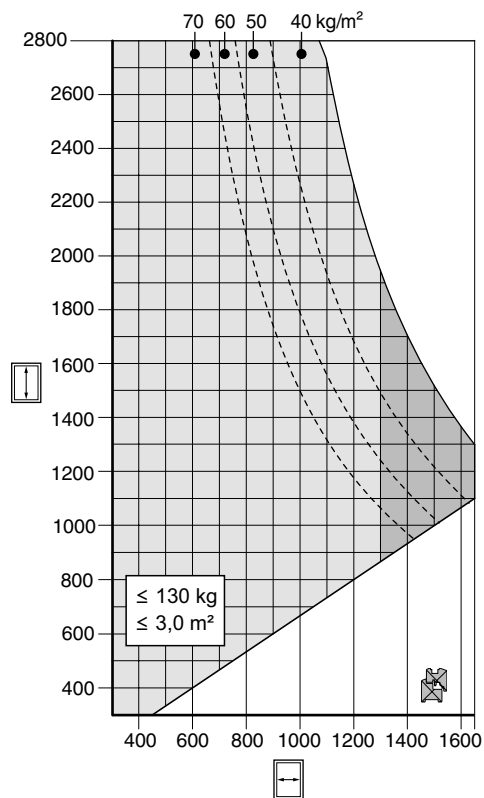

Permissible area

for timber profiles

Stabilising scissor stay required

Improper Area

All notes on the use of application diagrams in our print and online catalogues must be considered!

### Drilling with counter-move plates for pivot post and scissor stay hinge for timber FT 24



**CAUTION!**

\* Drilling at the frame edge should be offset so they don't collide!

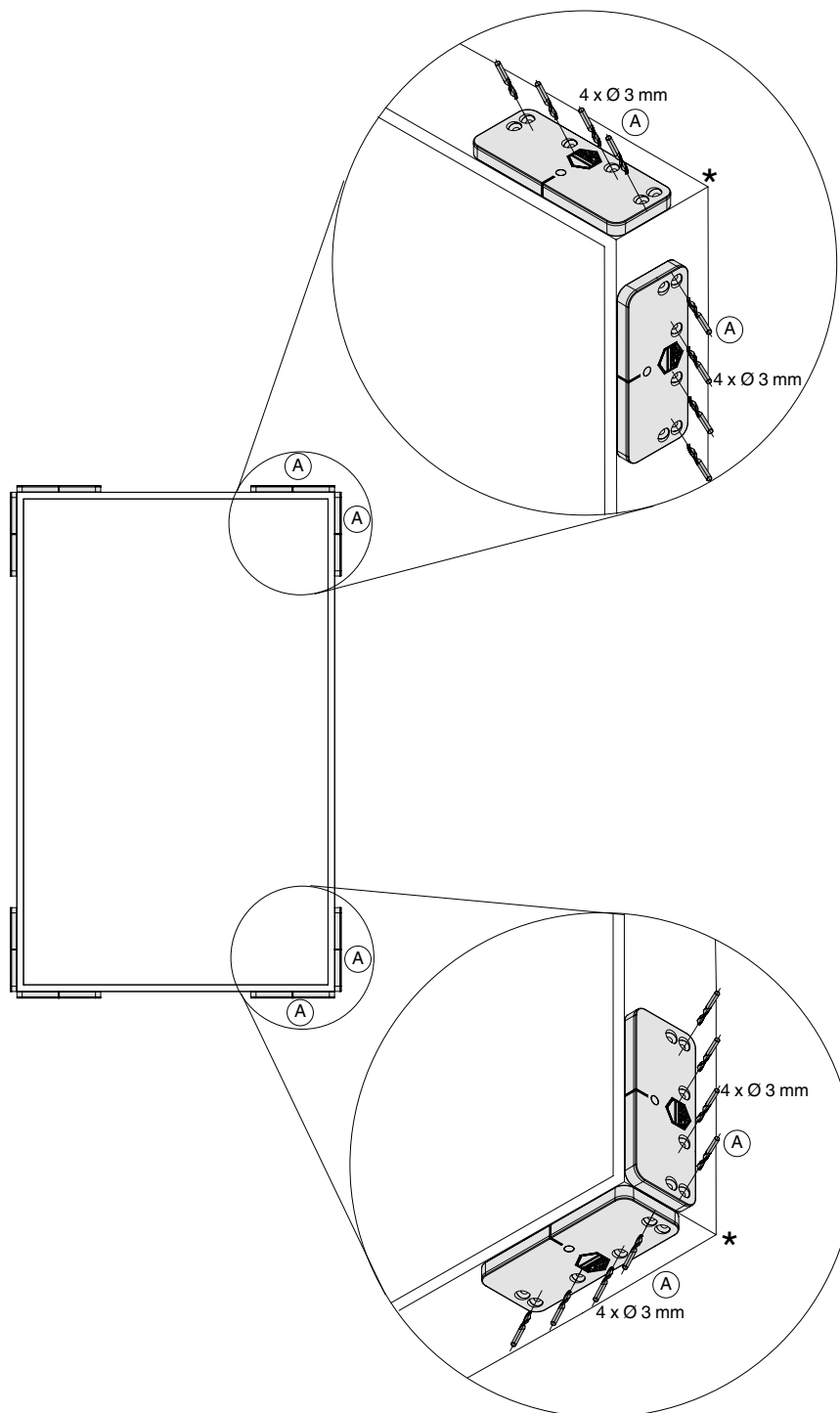

**CAUTION!**

\* Drilling at the frame edge should be offset so they don't collide!

1. Clamp the counter-move plates (A) Article No. 370425 with drill-holes to the rear, flush to the front edge of the frame and frame corner (pivot post and scissor stay hinge) and drill diagonally.

### Drilling image with counter-move plates for pivot post and scissor stay hinge for timber FT 24



#### CAUTION!

\* Drilling at the frame edge should be offset so they don't collide!



#### CAUTION!

The reference edge is the front edge of the frame with edge-mounted elements, and is the edge of frame rebate with flush mounted elements! Therefore, always position the front edge on the striker plate!

\*\* Üst = Rebate depth (only when flush)



#### CAUTION!

\* Drilling at the frame edge should be offset so they don't collide!

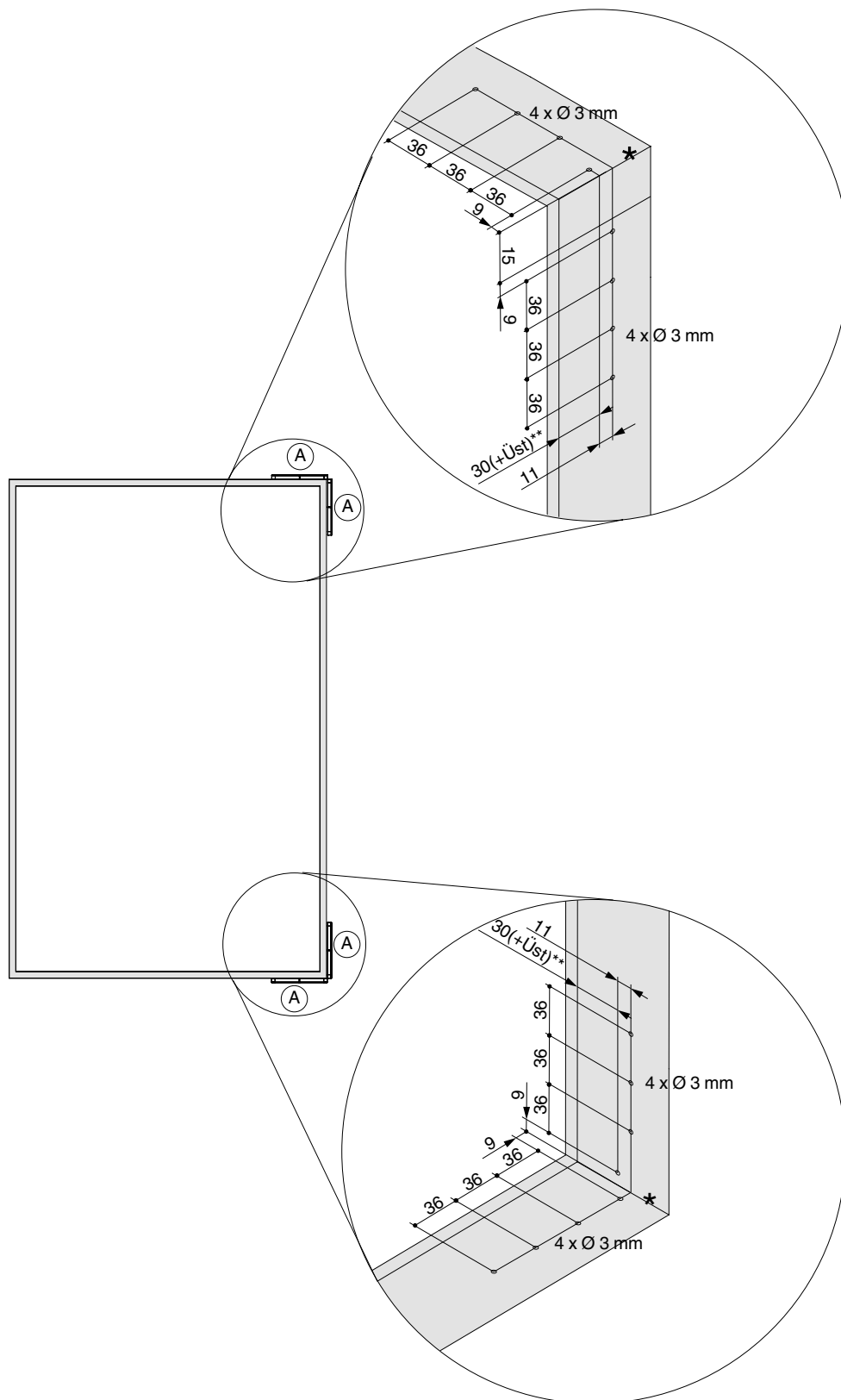

**Assemble the counter-move plates for pivot posts and scissor stay hinges for timber FT 24**

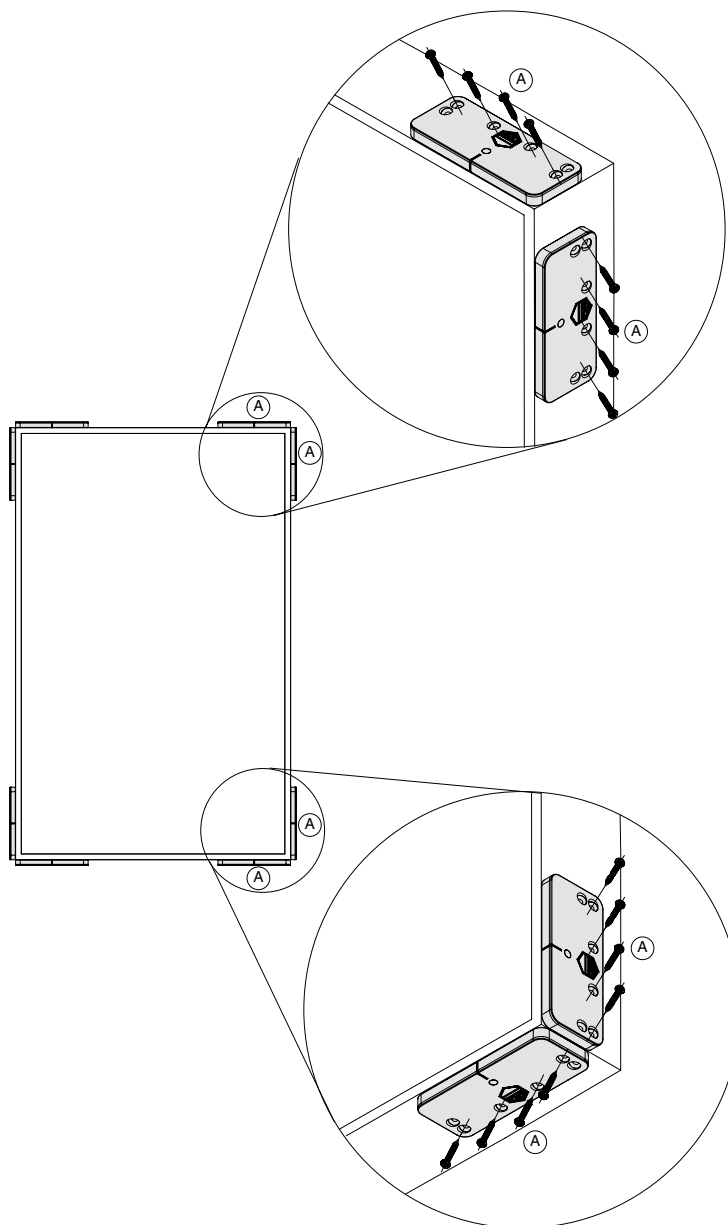

Screw in the counter-move plates (A) Article No. 370425. Use screws of min. Ø 4 x 30 mm.

**Drilling with jig for pivot post and scissor stay hinge for timber FT 24**

Drilling for pivot post and scissor stay hinge is carried out as described in the MULTI POWER assembly instructions.

**Drilling images for pivot post and scissor stay hinge**

The drilling images for pivot post and scissor stay hinge are as described in the MULTI POWER assembly instructions.

## Scissor arm with hinge assembly



### DANGER!

The fixing of the bearing parts must meet the requirements of the TSDK guidelines (quality association for locks and hardware - [www.schlossindustrie.de](http://www.schlossindustrie.de)).

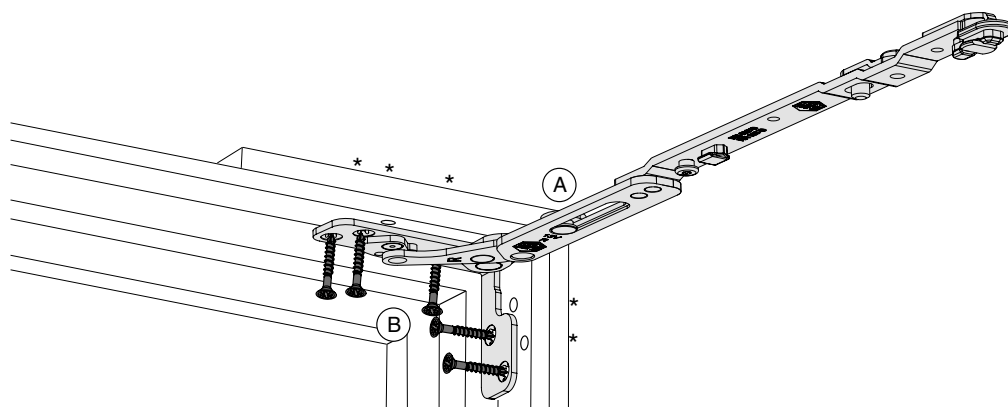

1. Insert scissor stay arm with hinge (A) opened in frame rebate corner and fix using special screw  $\text{\O} 4.5 \times 38 \text{ mm}$  (B) (Article No. 362918 and 367828)!
2. Cut off or grind down protruding screws (\*).



### WARNING!

To support the pivot post in timber with sash weights from 100 kg, use the support rawplug Article No. 36668!



### WARNING!

With timber, the pivot post must be rest on the entire surface!

Glue grooves (Euro-groove, groove for frame gasket).

## Pivot post assembly

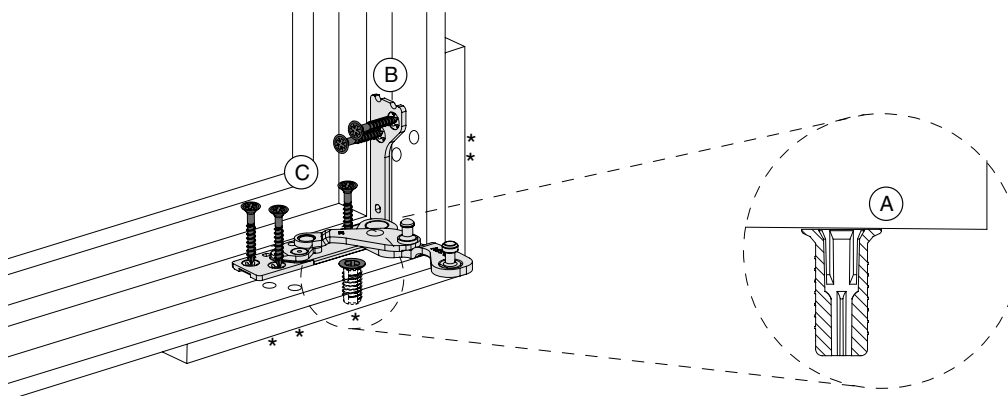

1. If necessary, turn in flush the support rawplug (A).
2. Insert pivot post (B) opened in frame rebate corner and fix using special screw  $\text{\O} 4.5 \times 38 \text{ mm}$  (C) (Article No. 362918 and 367828)!
3. Cut off or grind down protruding screws (\*).

### Sash lifter assembly



#### WARNING!

Counter-move plate is mandatory for use with sash lifter!

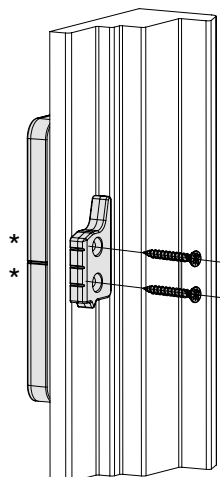

1. Mark the sash lifter position on the frame installation.
2. Align the counter-move plate (notch) on the sash lifter position and clamp onto the frame installation. Drill the counter-move plate diagonally and screw in.
3. Position the sash lifter, mark drill holes and pre-drill with  $\text{\O} 3$  mm drill.
4. Insert the sash lifter in the frame rebate and screw in.
5. Cut off or grind down protruding screws (\*).

### Striker plate assembly

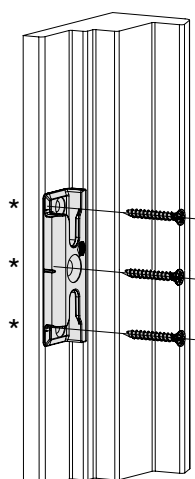

1. Mark the striker plate position on the frame installation.
2. Position the striker plate, mark drill holes and pre-drill  $\text{\O} 3$  mm drill.
3. Insert the striker plate in the frame rebate and screw in.
4. Cut off or grind down protruding screws (\*).

## Assembly of the elements in the wall opening

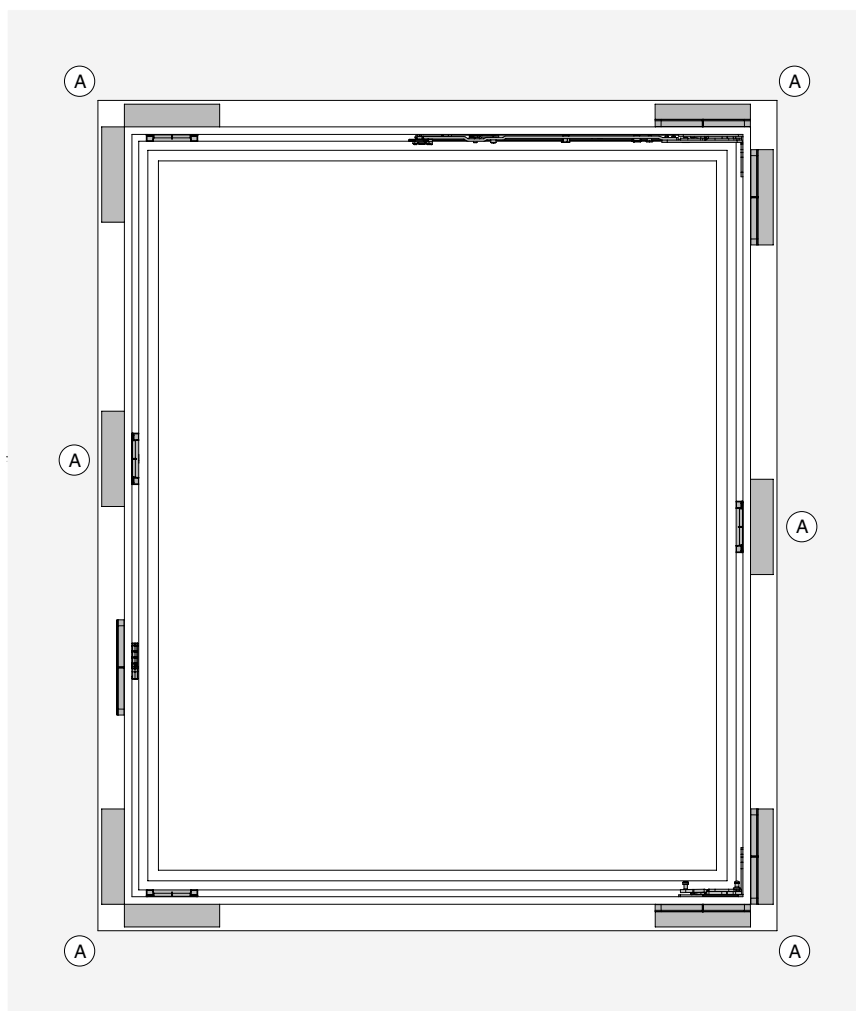

1. All pivot posts and striker plates (A) must be packed pressure-tight.

## Turn restrictor MULTI POWER



### WARNING!

In the case of heavy or wide sashes, as well as with soft woods, insert the mounting bracket backwards in the rebate. Installation size and opening angle will be smaller!

**Choose appropriate fixing!**

### Assembly

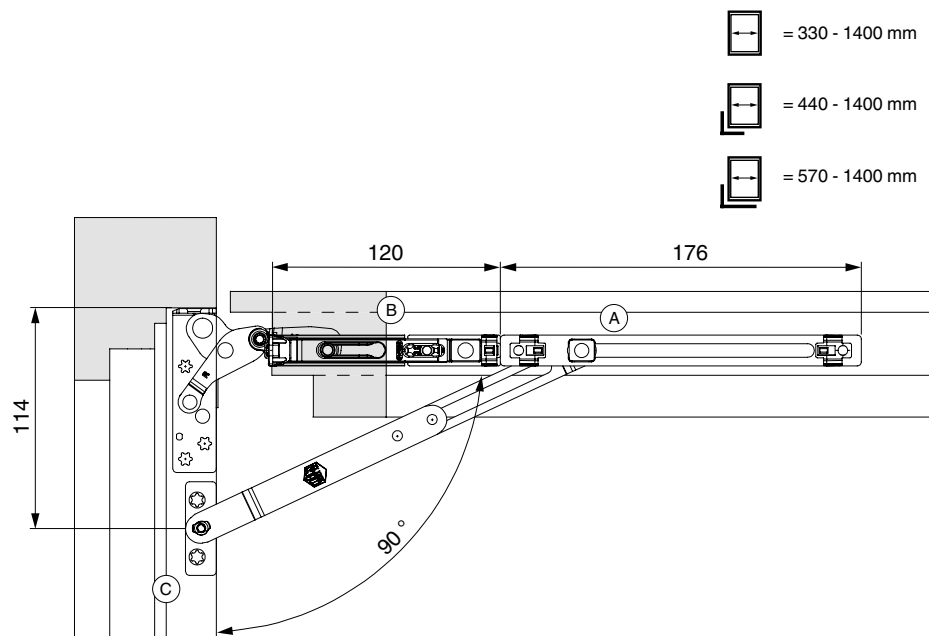

1. Mount the turn restrictor (A) on the rebated corner support (B) (see also Setting the Opening Angle).
2. Assemble the mounting bracket (C) flush on the edge of frame rebate. The outer middle screw holes have to point backwards!

### Setting the Opening Angle

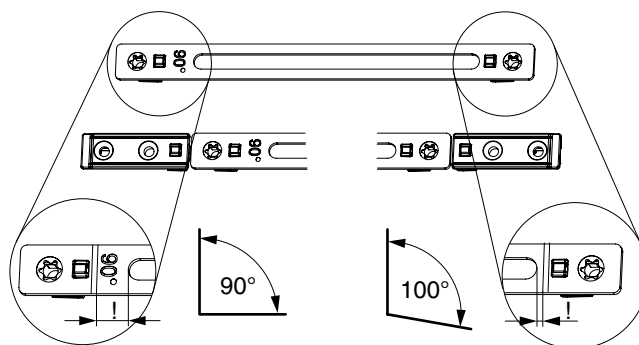

This side fitting to the rebated corner support => Opening Angle 90°

This side fitting to the rebated corner support => Opening Angle 100°

## MULTI POWER with opening restrictor

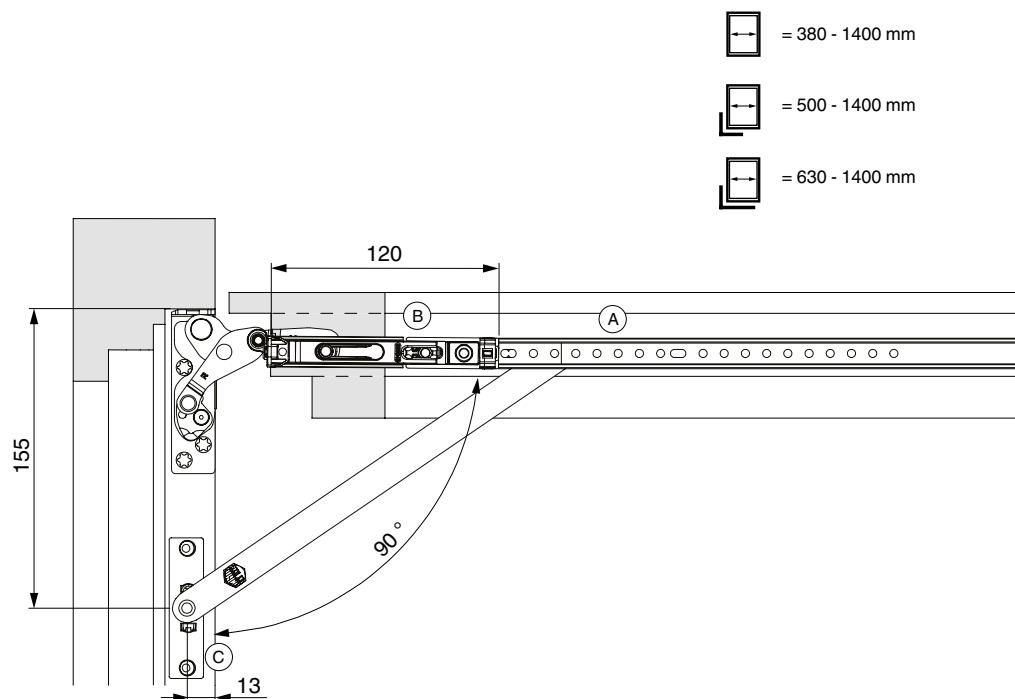

1. Assemble the opening restrictor (A) (Article No. 52977) on the rebated corner support (B).
- 2a. **Timber:** Locate the striker plate for the opening restriction (C) with slanting screw fixing at the back of the frame rebate and fix with the longest possible screws.
- 2b. **PVC:** see profile sheets, insert the striker plate (C) behind the locating slot in the frame rebate and screw in. Both screws must be fitted into the reinforcement! Opening angles can change minimally.
3. Insert the restrictor arm in the mounting bracket of the striker plate and turn the locking pin 180°.

### Correct setting of the brake:

The sash should still be able to be moved with little effort.  
A too weak or too strong brake setting leads to damage of the sash, frame and pivot post!

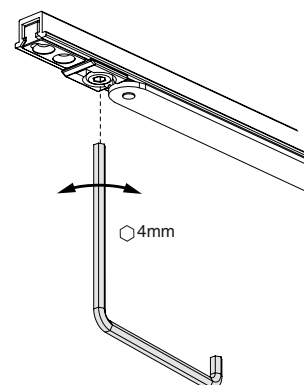

## MULTI POWER with comfort stop

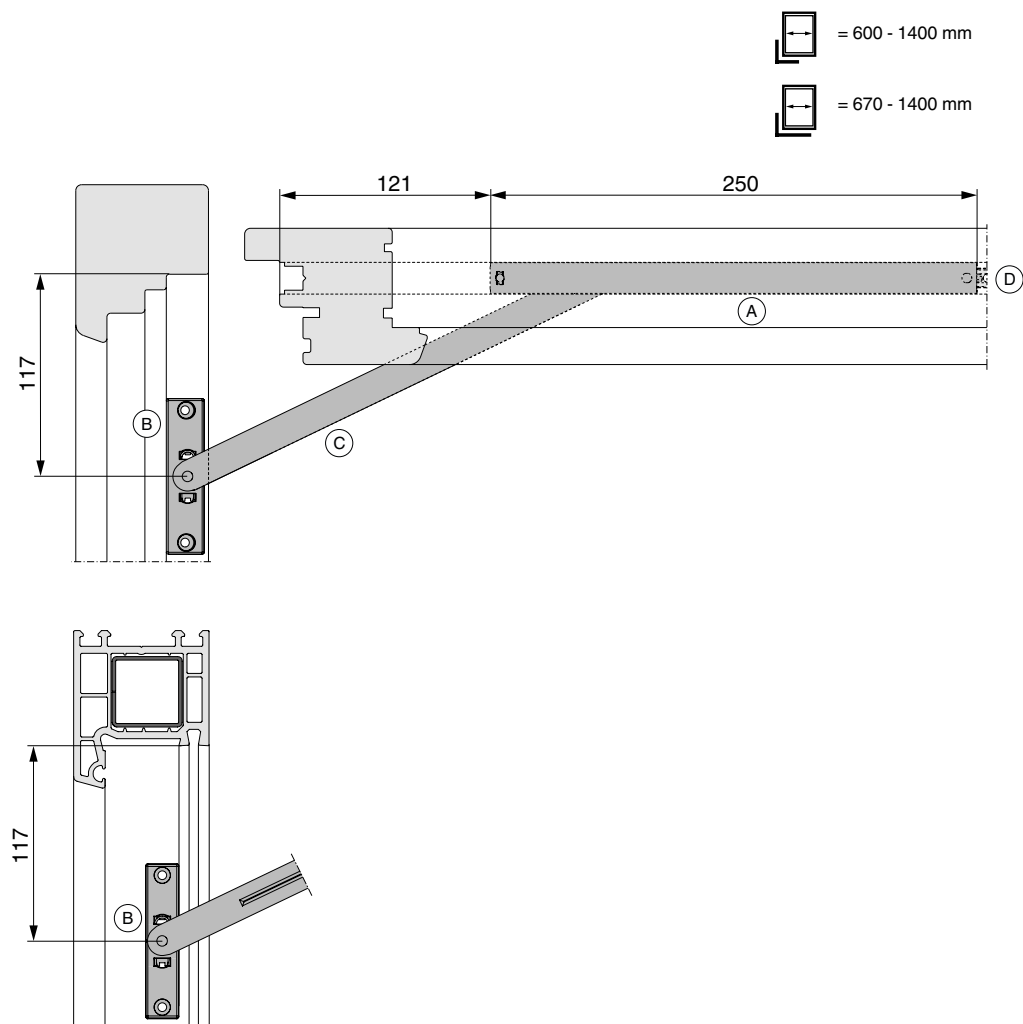

1. Assemble the comfort stop (A) (Article No. 105429) on the rebated corner support (B).
- 2a. **Timber:** Insert the frame part for comfort stop (C) (Article No. 228451) with slanted screw fixing at the back of the frame rebate and fix diagonally with screws at least  $\text{Ø } 4 \times 40 \text{ mm}$ .
- 2b. **PVC:** Insert the frame part for comfort stop (C) (Article No. 228785) behind the locating slot and screw in. Both screws must be fitted into the reinforcement!
3. For connection with central lock (D) see instruction leaflet!

## Supplementary Information

### Hinging the Turn&Tilt sash

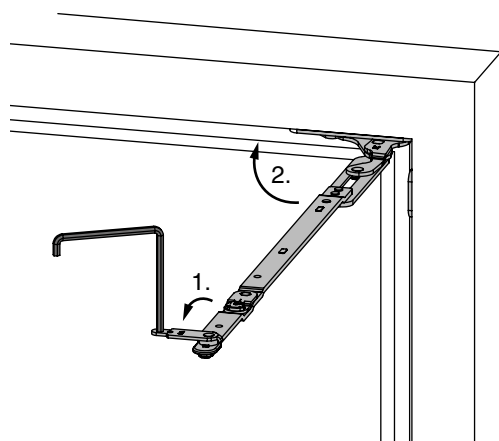

1. Open the scissor stay catch with Allen Key SW 4.
2. Swing the scissor arm into the frame.

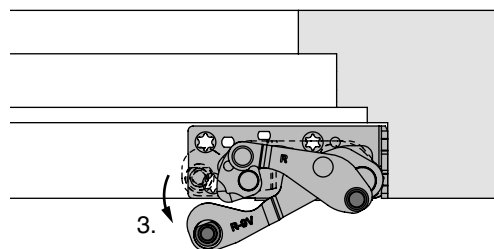

3. Open pivot post approx. 5°. The pivot post pins should be approx. 10 mm in front of the frame edge.

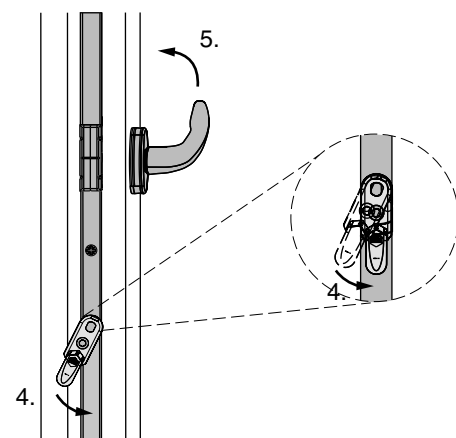

4. Activate mishandling device and hold.
5. Turn grip to tilt position, release mishandling device.

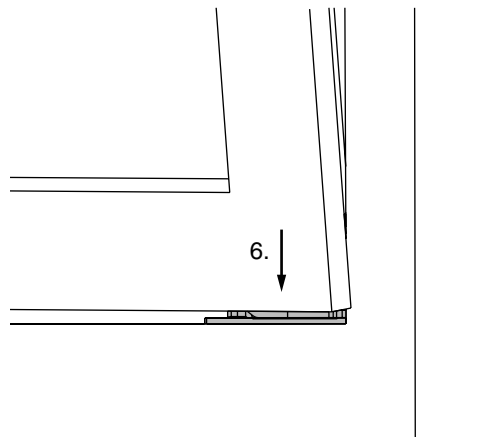

6. Hang the sash parallel to the frame and slightly tilted onto both pivot post pins. Open the sash 90° and hold position.

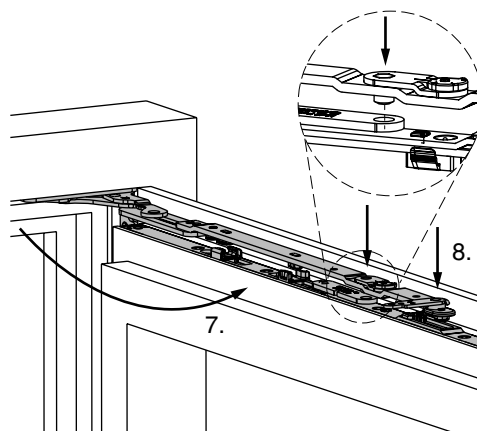

7. Swing scissor arm 90° out of the frame.
8. Engage the scissor arm in the scissor stay faceplate (side adjustment pins in the drill holes in scissor stay guide).

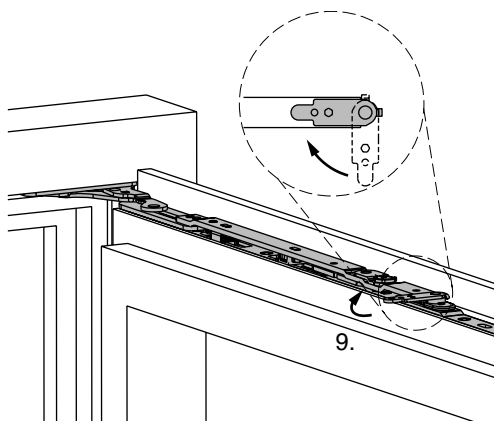

9. Close scissor stay catch.

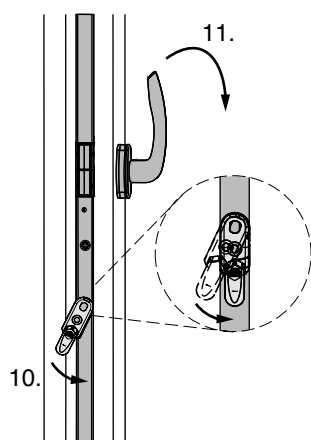

10. Activate mishandling device and hold.

11. Turn grip to turn position, release mishandling device.

## Hinging the Turn-only sash

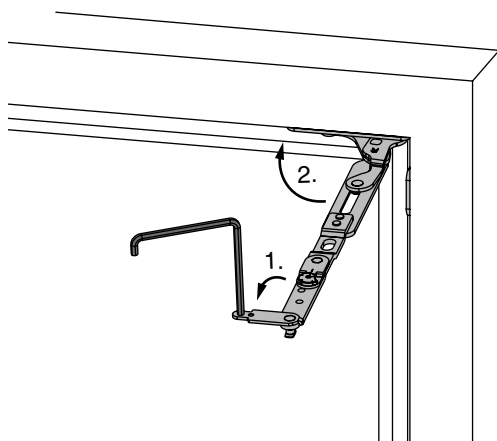

1. Open the turn-only hinge arm catch with Allen Key SW 4.
2. Swing the turn-only hinge arm into the frame.

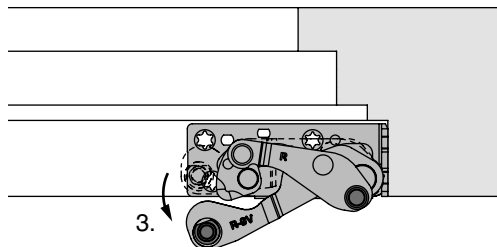

3. Open pivot post approx. 5°. The pivot post pins should be approx. 10 mm in front of the frame edge.

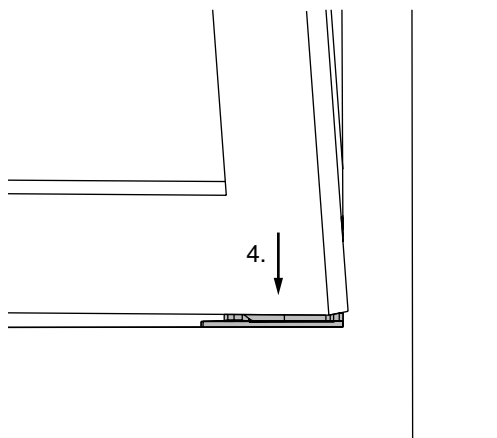

4. Hang the sash parallel to the frame and slightly tilted onto both pivot post pins. Open the sash 90° and hold position.

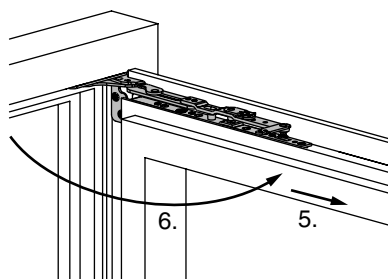

5. Lower the sash slightly on the drive motor side and hold position.
6. Tilt out the turn-only hinge arm by 90°.

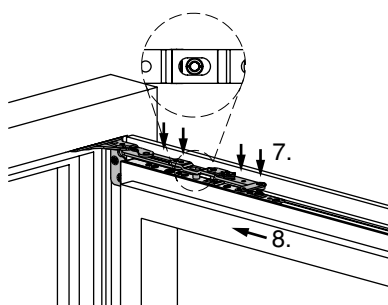

7. Press the turn-only hinge arm onto the turn-only hinge faceplate.
8. Lift the sash on the drive motor side until the turn-only hinge arm catch grips into the turn-only hinge faceplate, and the pins for the gasket compression of the faceplate sit in the turn-only arm guide.

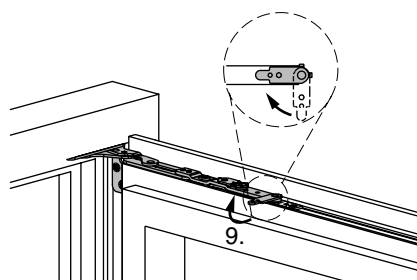

9. Close the turn-only hinge arm catch.

## Unhinge the Turn&Tilt sash

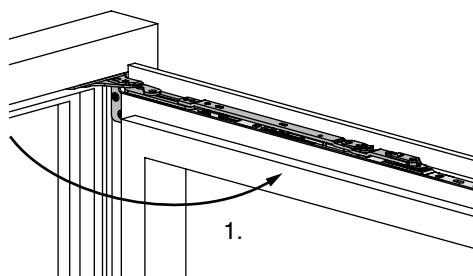

1. Open the sash 90°.

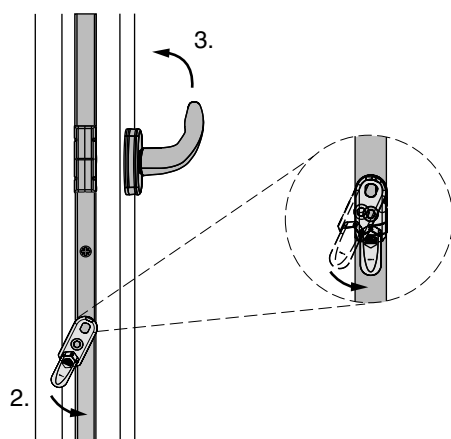

2. Activate mishandling device and hold.

3. Turn grip to tilt position, release mishandling device.

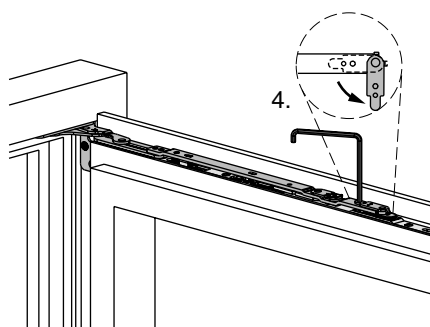

4. Open the scissor stay catch with Allen Key SW 4.

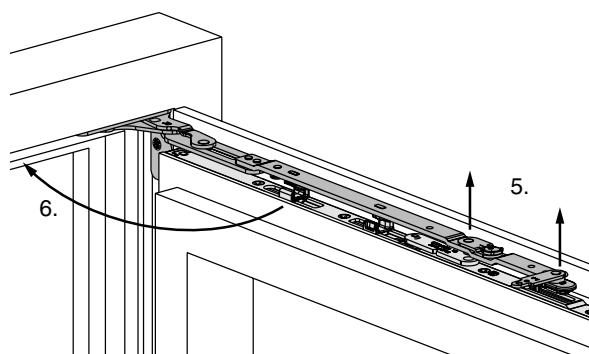

5. Lift out the scissor stay arm upwards from the scissor stay faceplate until it is completely free. Hold the sash in position.
6. Swing the scissor arm into the frame.

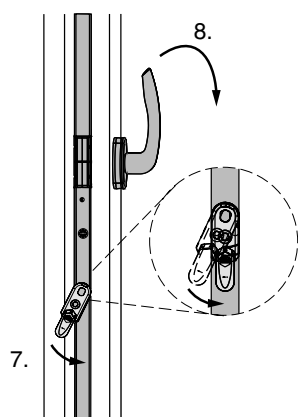

7. Activate mishandling device and hold.
8. Turn grip to turn position, release mishandling device and close sash.

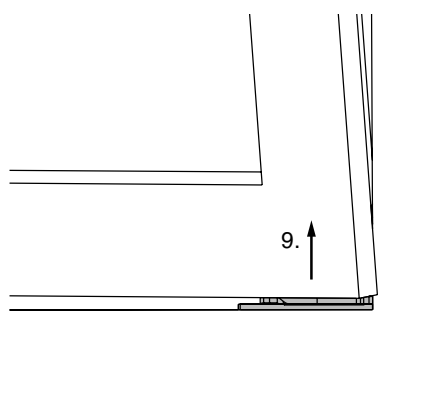

9. Slightly tilt the sash and lift out upwards.

## Unhinging Turn-only sash

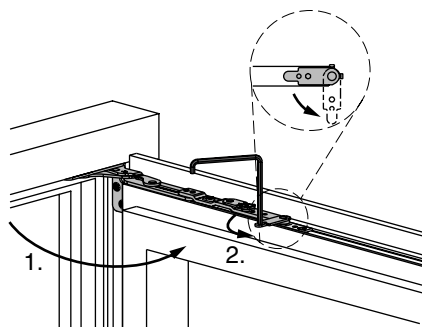

1. Open the sash 90°.
2. Open the turn-only hinge arm catch using Allen Key SW 4.

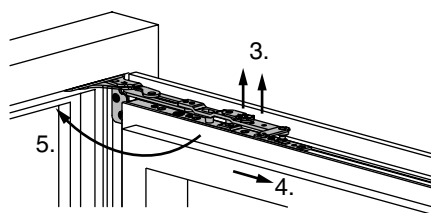

3. Slightly lift the sash on the drive motor side until the turn-only hinge arm is free and can be lifted. Lift the turn-only hinge arm until it is completely free.
4. Slightly lower the sash on the drive motor side.
5. Swing the scissor arm into the frame and close the sash.

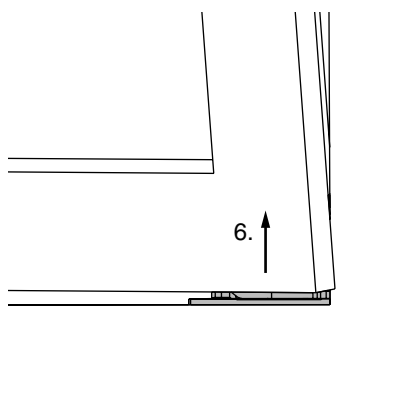

6. Slightly tilt the sash and lift out upwards.

## Exchange of anti-slam device or scissor stay restrictor

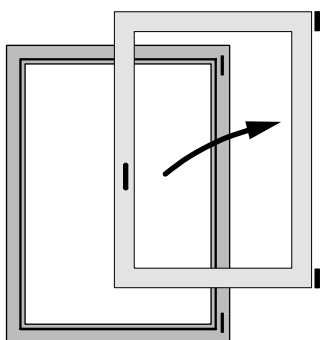

1. Unhinge the sash.

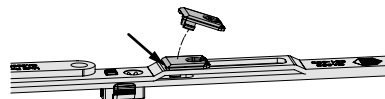

2. Lift out the anti-slam device with a small flat screwdriver.

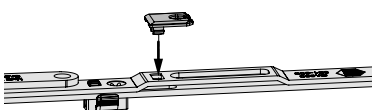

3. Clip in the anti-slam device (Article No. 369474) and scissor stay restrictor (Article No. 366011 or 366012) in the opening from above.

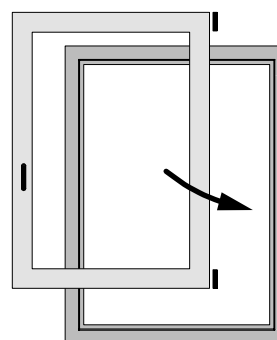

4. Hinge the sash.



### Adjusting of pivot post and scissor stay hinge

All adjustment information can be found in the maintenance and adjustment instructions Order No. 757071.

### Maintenance Information

All maintenance information can be found in the operating and maintenance instructions Order No. 757070.

### Notes for security windows according to EN 1627

The construction of security windows in accordance with the European Standard must be carried out according to precisely defined guidelines. More information can be found on our website ([www.maco.eu](http://www.maco.eu)) or from our specialist partners.



## Notes

A large rectangular area filled with a fine grid pattern, intended for taking notes or drawing technical diagrams.



## Notes

A large rectangular area filled with a fine grid pattern, intended for taking notes.

**MACO  
MULTI-MATIC**



**MAYER & CO  
BESCHLÄGE GMBH**

Alpenstraße 173  
A-5020 Salzburg

Tel.: +43 662 6196-0  
E-Mail: [maco@maco.eu](mailto:maco@maco.eu)  
[www.maco.eu](http://www.maco.eu)

## **Satisfied?**

We look forward to your  
[feedback@maco.eu](mailto:feedback@maco.eu)

Order No. 757808 - Date: March 2019 - Date of change: September 2019

All rights and amendments reserved.

Image source: MACO

This print document is revised regularly.  
The latest version is available at  
<http://www.maco.eu/sites/assets/MacoDocs/757712/757808.pdf>  
or scan the QR code.

