

COMUNELLO
GATE DIVISION

Life
made
easy

GATE HARDWARE TECHNICAL MANUAL



COMUNELLO

GATE DIVISION

Index

Precisely 50 years	04
Tutto, di più e meglio / <i>A huge range of the finest products</i>	06
Il rapporto tra misure e resistenza / <i>The relationship between size and resistance</i>	08
Configuratore online / <i>Web configurator</i>	10
01 Cardini e perni / Battenti d'arresto <i>Hinges and pins / Gate stops</i>	18
02 Copri pilastri <i>Pillar covers</i>	70
03 Arresti <i>Stops</i>	74
04 Piastre e olive <i>Plates and rollers</i>	82
05 Cremagliere <i>Racks</i>	94
06 Binari <i>Tracks</i>	100
07 Ruote <i>Wheels</i>	110
08 Cerniere <i>Hinges</i>	140
09 Chiusure / Incontri per serrature <i>Closures / Latch strike plates</i>	174
10 Cancelli autoportanti <i>Cantilever systems</i>	206
11 Portoni industriali <i>Industrial door systems</i>	276
Product index	368

Life
made
easy



1965-2015

Precisely 50 Years

Cinquant'anni precisi da quando il fondatore, Vittorio Comunello, ha intrapreso la sua avventura pionieristica creando un'azienda produttrice di componenti per cancelli scorrevoli che in breve conquista, e tuttora mantiene, una posizione di leader sul mercato per innovazione e ricerca della qualità assoluta.

It's precisely 50 years since our founder, Vittorio Comunello, started on his pioneering adventure to build a company for the production of components for sliding gates. The company was an instant success and has maintained its reputation and market position based on innovative solutions and an unrivalled reputation for absolute quality.

Cinquant'anni di precisione nella realizzazione di elementi perfetti, sempre al passo con l'evoluzione delle più avanzate tecnologie ed in grado di garantire i più alti standard di sicurezza.

50 years of precision in the manufacture of perfect components, maintaining pace with the evolution of the most advanced technologies while guaranteeing complete security and safety.

COMUNELLO
GATE DIVISION



Tutto, di più e meglio.

A huge range of the finest products.

La storica **Divisione Gate** di Comunello propone da sempre sul **mercato nazionale ed internazionale** la più vasta gamma di componenti per cancelli scorrevoli e portoni industriali dai più leggeri ai più pesanti e dai più piccoli ai più grandi. La più ampia scelta di misure e l'impiego di materiali come alluminio ferro ed acciaio inox completano il valore di un'offerta davvero unica ed in grado di rispondere alle **esigenze di tutte le tipologie** di apertura di qualunque dimensione esse siano.

*The Comunello **Gate Division** has built a reputation in Italy and across the world for providing the widest range of components for sliding gates and industrial doors of all weights and all sizes. Our vast range of solutions and use of high quality materials including stainless steel and aluminium bring real value to a product offering which is truly unique and which delivers solutions for **all gate types**, whatever the size.*



Il rapporto tra dimensione...e resistenza

The relationship between size and resistance

3 scelte di dimensione 3 different size options

Pioniere nella produzione di componenti per cancelli autoportanti, Comunello ha concepito e sviluppato tre misure di carrelli, e cioè **Mini Piccolo e Grande**, per consentire la progettazione di ogni tipo di cancello. Ogni misura è corredata da una gamma completa di accessori.

*As pioneers in the production of cantilever gates, Comunello has designed and developed three rack sizes, **Mini, Piccolo & Grande**, allowing total freedom of design for every gate type. A complete set of accessories is available for each rack size.*



3 livelli di resistenza 3 levels of resistance

Per ogni misura di carrello esistono tre livelli di resistenza: **Regular, High e Max**. Riducendo l'interasse tra i carrelli, la forza su ogni carrello per reggere il cancello autoportante aumenta progressivamente.

*Each rack is available with three resistance levels, **Regular, High & Max**. Reducing the rack wheelbase produces a progressive increase in the forces required to support the gate.*



MINI

PICCOLO

GRANDE

REGULAR
FORCE
CANTILEVER SYSTEM

HIGH
FORCE
CANTILEVER SYSTEM

MAX
FORCE
CANTILEVER SYSTEM

Configuratore online

Web Configurator

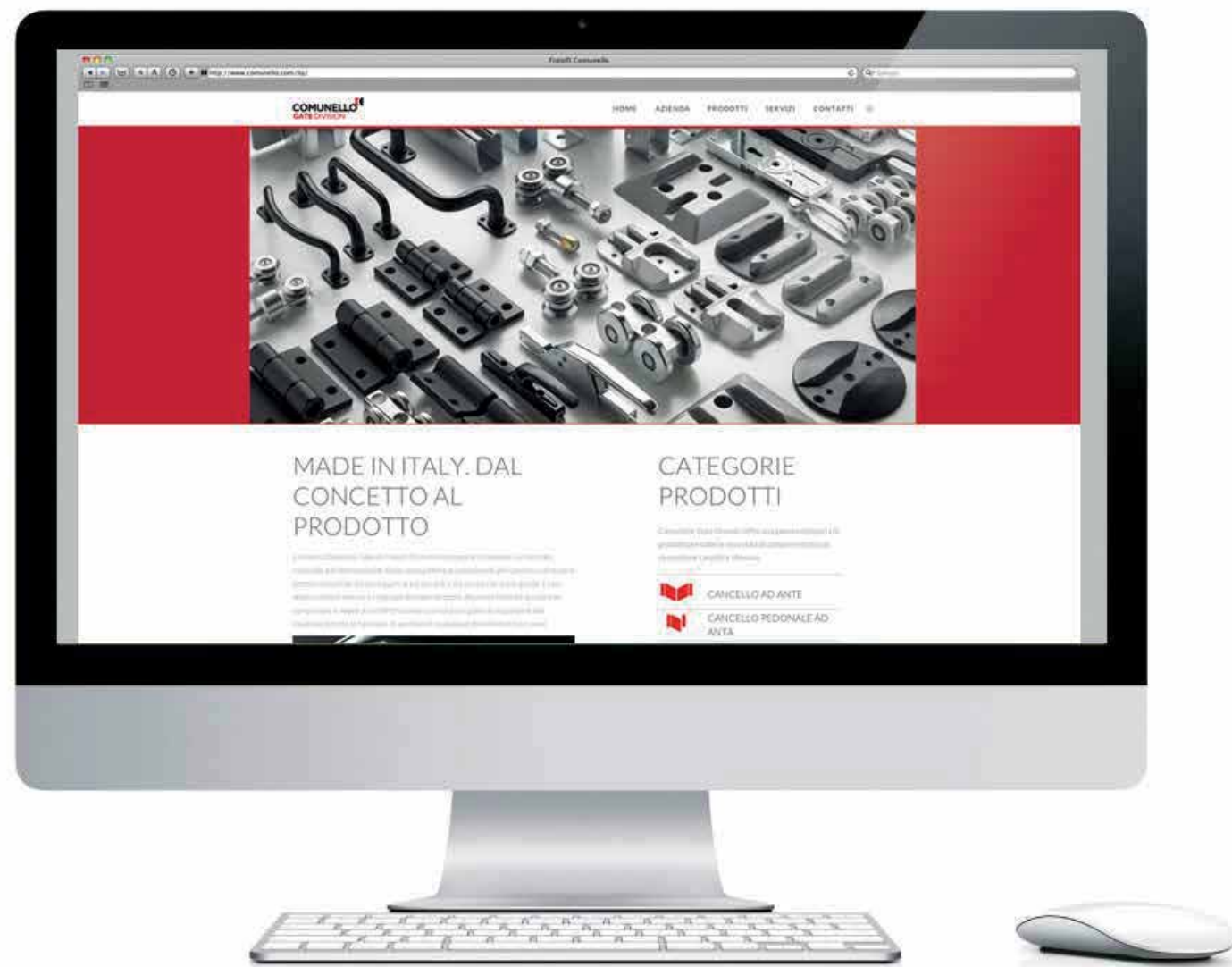

Sempre al passo coi tempi e con le nuove tecnologie digitali, l'azienda ha creato delle speciali **applicazioni web-based**, utilizzabili anche da dispositivi mobili quali smartphone e tablet. Tali applicativi, caratterizzati da un approccio semplice ed intuitivo, consentono una selezione precisa dei prodotti Comunello Gate Division inserendo alcuni dati di base come: **la misura, il peso e le dimensioni del cancello**. I configuratori sono differenziati nelle principali aree funzionali di impiego degli accessori per cancello: cancello cantilever, cancello scorrevole, cancello battente.

*Comunello is committed to remaining at the forefront of technological and digital evolution and has developed a range of **web-based applications** for use across all mobile devices and platforms. These apps are designed to be easy and intuitive to use and provide access to the full range of Comunello products simply by entering a few key pieces of information on **gate size, weight and dimensions**. Configurators are available for all gate types: Cantilever, Sliding and Swing.*

Residential sliding gates

Configuratore cancello scorrevole.
Scegli dalla nostra gamma di componenti
di alta qualità.

Sliding gate configurator.
Choose from our vast range of
high quality components.



Incontri superiori Upper end



ART.	PAG.
199	76
203	81
204	80

Serrature e accessori Locks and accessories



ART.	PAG.
210	179
211	179
213	180
215	180
215S	180
216	181
217	181
220	181
222	182
223	182

Piastre / Plates



ART.	PAG.
247	87
247F	88
250	88
251	89
252	90
253	90
255	91
256	92
257	91
258	93
CG-251	271
CG-252	272

Arresti di fine corsa Runaway stops



ART.	PAG.
200	76
200i	76
201	78
202	77
202A	81
202F-A	77
202F-C	77

Cremagliere e attacchi Racks and supports



ART.	PAG.
260	96
261	96
262	97
263	97
264	98
265	99
266	99

Binari / Tracks



ART.	PAG.
287	102
287-FP	103
289	104
290	105
291	105
292	106
293	106
294	107
295	107
297	108
297 G	108

Ruote / Wheels



ART.	PAG.
300 series	112-113
305 series	113-115
306	115
307	116
308	116
309	118
310	117
315	119
320 series	120-121
322 series	121-122
323	123
324	123
325 series	124-125
326 series	125
327	126
328	126
330 series	127-128
332	129
333 series	129-130
334	130
335 series	131-133
336 series	133-135
337	135
338	136
339 series	137-139
340	139
342	139

Residential swing gates

Configuratore cancello battente.
Scegli dalla nostra gamma di componenti
di alta qualità.

Swing gate configurator.
Choose from our vast range of
high quality components.



Serrature e accessori
Locks and accessories



ART.	PAG.
73	176
74	177
78	178
80	178

Cardini e piastre/ Hinges and plates

ART.	PAG.	ART.	PAG.	ART.	PAG.
81	20	100	38	161	52
82	21	100PST	37	162	52
85	22	105	39	163	52
85L	24	105PST	37	164	53
85PST	24	106	37	172	54
85XL	23	106PST	40	174	55
86P	24	110	41	175	56
86G	25	115	41	176	53
86L-P	26	115PST	42	178	57
86L-G	26	117	42	180	58
86PST	26	117PST	43	182	59
87P	27	120	44	184	58
87	28	125	43	185	58
87L-P	29	130	46	186	60
87L	30	135	45	188	60
87PST P	29	140	46	189	60
87PST	31	150	46	190	61
87XL	32	154	47	192	61
88	33	154R-CV	48	194	61
88L	34	155	49	194 PST	62
88PST	34	157CV	47	196	62
89	34	157AL	47	198	62
90	35	159	50	282	63
92G	36	159R-CV	50	285	63
94	36	160	51		
96G	36	160 XL	50		

Battenti
Stops



ART.	PAG.
166	66
167	66
168	66
169	67
170	68
171	69

Arresti di fine corsa
Runaway stops



ART.	PAG.
201	78
202	77
202F-B	79

Pedestrian gates

Configuratore cancello pedonale.
Scegli dalla nostra gamma di componenti
di alta qualità.

Pedestrian gate configurator.
Choose from our vast range of
high quality components.



Serrature e accessori Locks and accessories



ART.	PAG.
73	176
74	177
78	178
80	178
205	178
209	179
210	179
211	179
213	180

Cardini / Hinges



ART.	PAG.	ART.	PAG.	ART.	PAG.
81	20	100	38	161	52
82	21	100PST	37	162	52
85	22	105	39	163	52
85L	24	105PST	37	164	53
85PST	24	106	37	172	54
85XL	23	106PST	40	174	55
86P	24	110	41	175	56
86G	25	115	41	176	53
86L-P	26	115PST	42	178	57
86L-G	26	117	42	180	58
86PST	26	117PST	43	182	59
87P	27	120	44	184	58
87	28	125	43	185	58
87L-P	29	130	46	186	60
87L	30	135	45	188	60
87PST P	29	140	46	189	60
87PST	31	150	46	190	61
87XL	32	154	47	192	61
88	33	154R-CV	48	194	61
88L	34	155	49	194 PST	62
88PST	34	157CV	47	196	62
89	34	157AL	47	198	62
90	35	159	50	282	63
92G	36	159R-CV	50	285	63
94	36	160	51		
96G	36	160 XL	50		

Arresti per ante battenti Gate stops



ART.	PAG.
201	78
202	77
202F-B	79

Catenacci Bolt latches



ART.	PAG.	ART.	PAG.	ART.	PAG.
710	191	800	197		
712	191	805	198		
714	191	810	198		
716	192	820	198		
720	193	825	199		
725	192	827	199		
730i	192	835	200		
735	194	837	200		
737	194	840	201		
740	195	840D	201		
745	195	852	202		
750	196	855	202		
752	196	857	203		
755	196	860	203		
760	197	862	203		



CARDINI & PERNI
HINGES & PINS

01



81

Cardine superiore con cuscinetto
Upper hinge with bearing
Gond supérieur avec roulement
Oberes Torband mit Kugellager
Bisagra superior con rodamiento
Верхняя петля с подшипником



CODE	ART.	D	E	F	G	H	L	M	N	R	Portata Capacity	Box info	
												Pcs per pack	Kg
10822505 001	81-M22	25	18	Ø49	25	34	123	M22	56	55-95	150 kg	10	7,8
10822510 001	81-M24	25	26	Ø62	27	36	130	M24	60	65-100	200 kg	10	10,8

Finishing: Zincato / Galvanized

Categoria commerciale: 1A

La portata è riferita ad una coppia di cardini nel caso di peso uniformemente distribuito in un'anta con L=H.
Weight bearing capacity refers to a pair of hinges mounted on a gate with weight uniformly distributed on a leaf with proportions L=H.

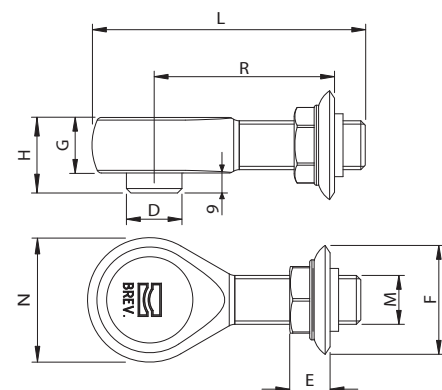

82

Cardine inferiore con cuscinetto
reggi spinta
Bottom hinge with thrust bearing
Gond inférieur avec roulement de butée
Unteres Torband mit Drucklager
Bisagra inferior con rodamiento de empuje
Нижняя петля с упорным подшипником



CODE	ART.	D	E	F	G	H	L	M	N	R	Portata Capacity	Box info	
												Pcs per pack	Kg
10823005 001	82-M22	50	18	Ø49	24	50	123	M22	56	55-95	150 kg	10	10,4
10823010 001	82-M24	50	26	Ø62	26	55	130	M24	60	65-100	200 kg	10	10,9

Finishing: Zincato / Galvanized

Categoria commerciale: 1A

La portata è riferita ad una coppia di cardini nel caso di peso uniformemente distribuito in un'anta con L=H.
Weight bearing capacity refers to a pair of hinges mounted on a gate with weight uniformly distributed on a leaf with proportions L=H.

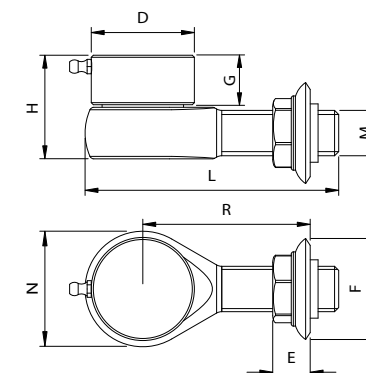

Mounting instructions art. 81

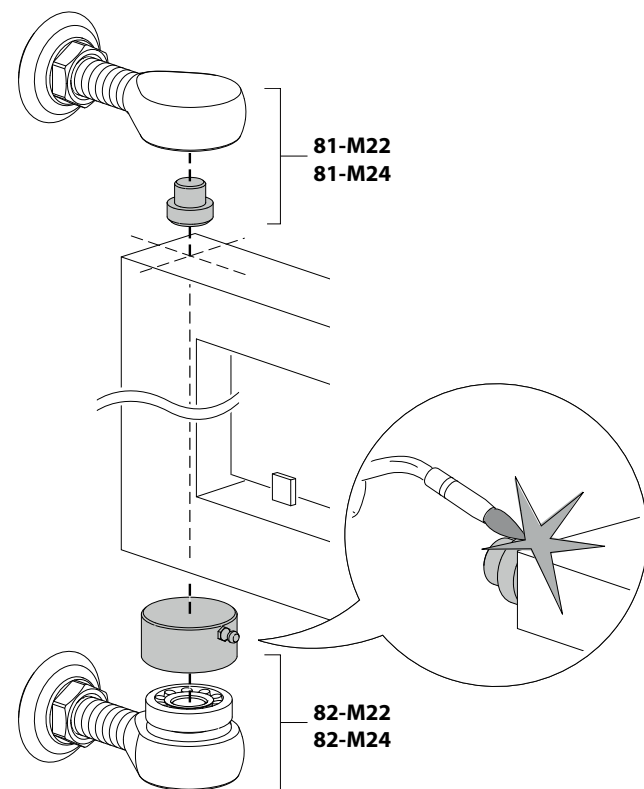

Mounting instructions art. 82

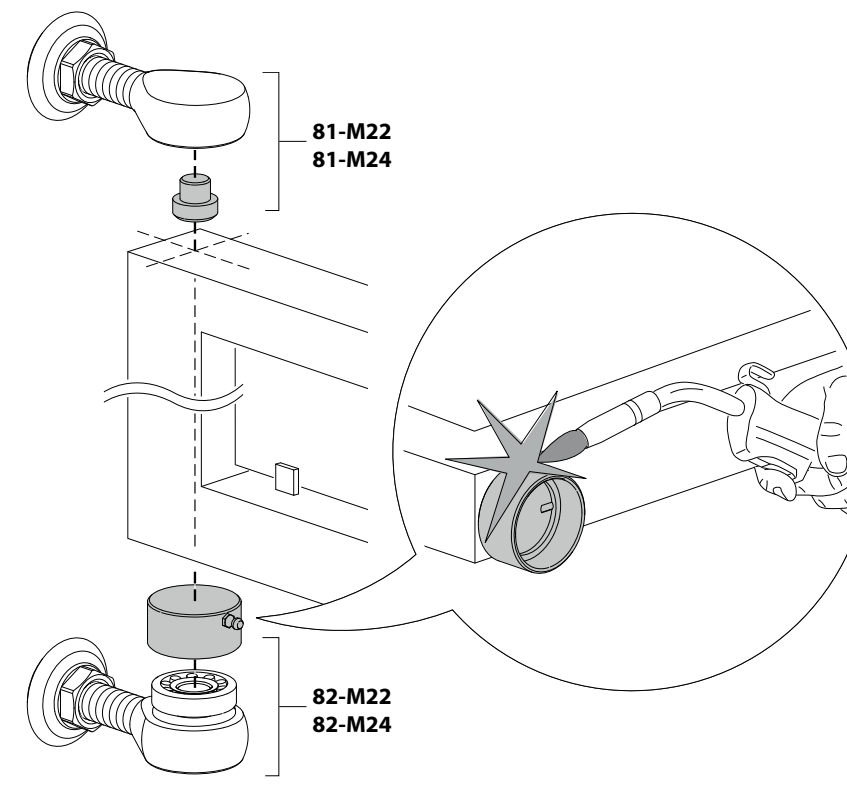



85

Cardine superiore regolabile
con piastra a saldare
Adjustable upper hinge with plate to be welded
Gond supérieur réglable avec platine
Verstellbares oberes Torband mit Platte
Bisagra superior regulable con placa
Верхняя регулируемая петля с пластиной



CODE	ART.	Size	A	C	D	H	L	N	R	S	Portata Capacity	Box info	
												Pcs per pack	Kg
10800407 001	85M	Medio Ø50	50	9	Ø25	62	100	Ø48	70-85	10	450 kg	4	3,4
10800410 001	85G	Grande Ø70	60	15	Ø35	72	130	Ø68	90-105	10	650 kg	2	3,2

Finishing: Zincato / Galvanized

Categoria commerciale: 1A

La portata è riferita ad una coppia di cardini nel caso di peso uniformemente distribuito in un'anta con L=H.
Weight bearing capacity refers to a pair of hinges mounted on a gate with weight uniformly distributed on a leaf with proportions L=H.

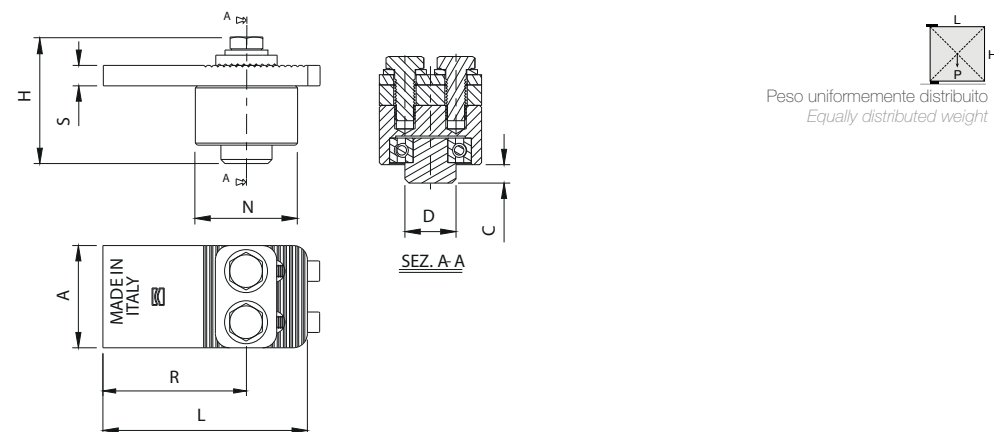

85XL

Cardine superiore pesante doppia
regolazione e piastra a fissare
Heavy upper hinge double adjustment and plate to be screwed
Gond supérieur lourd double réglage platine à visser
Schweres oberes Torband Doppelverstellung und Platte zum Anschrauben
Bisagra superior pesada doble regulación y placa para fijar
Верхняя тяжелая петля с двойным регулированием и приклеиваемой пластиной



CODE	ART.	Size	R	Portata Capacity	Box info	
					Pcs per pack	Kg
10800411 001	85XL	Maxi	130-165	4000 kg	1	11,6

Finishing: Zincato / Galvanized

Categoria commerciale: 1A

La portata è riferita ad una coppia di cardini nel caso di peso uniformemente distribuito in un'anta con L=H.
Weight bearing capacity refers to a pair of hinges mounted on a gate with weight uniformly distributed on a leaf with proportions L=H.

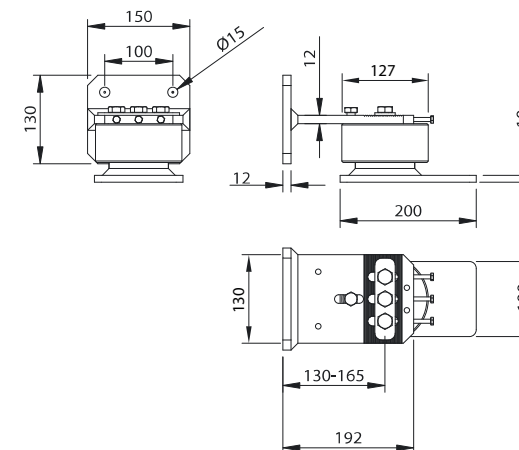

Cover for art. 85XL



Mounting instructions art. 85

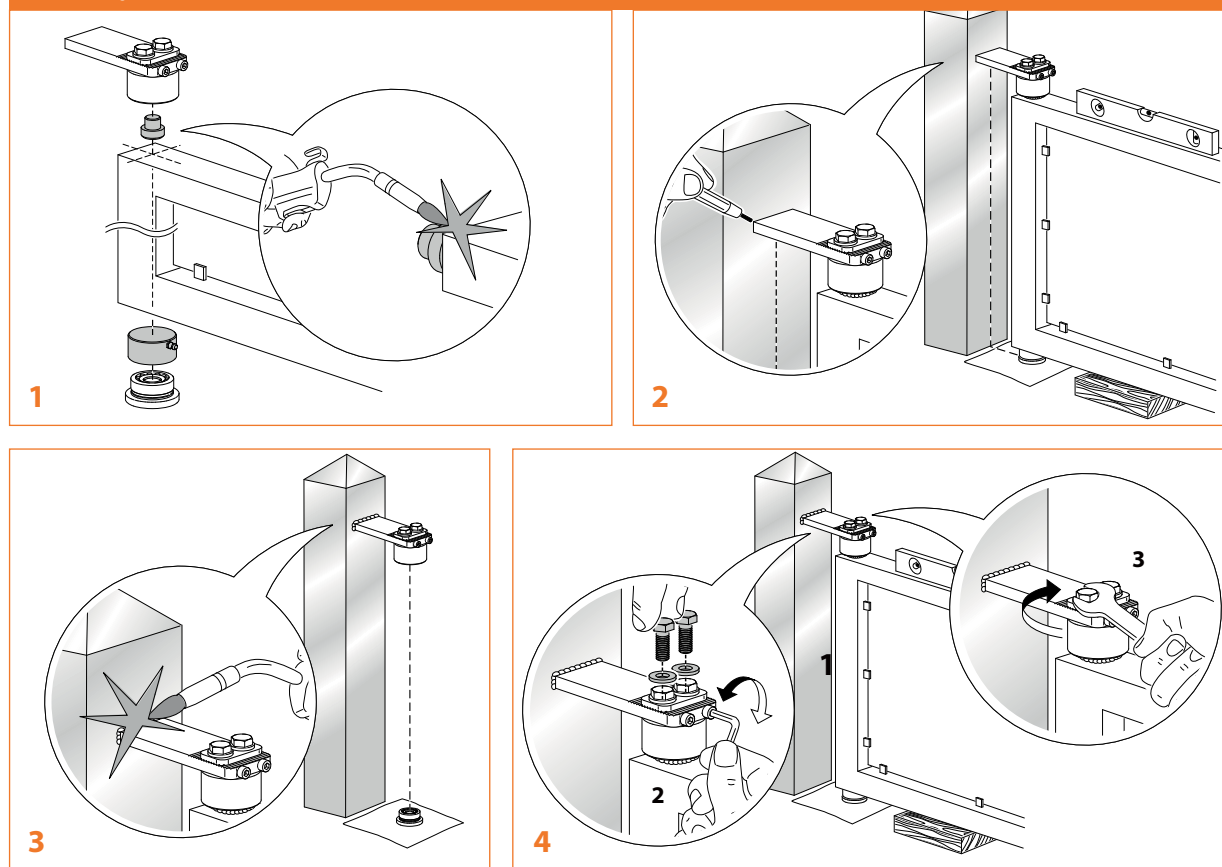

Mounting instructions art. 85XL

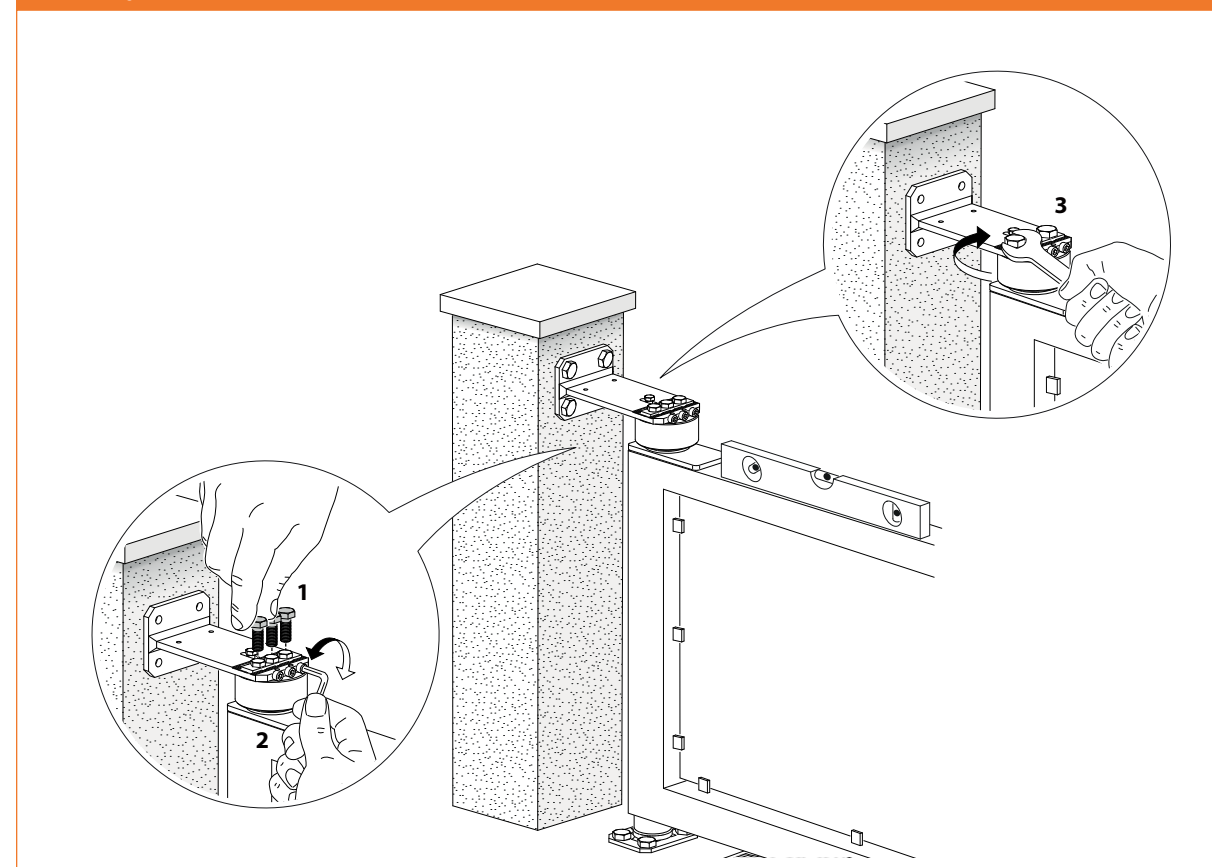



85L

Cardine superiore regolabile con piastra a L

Adjustable upper hinge with L plate
Gond supérieur réglable avec platine à L
Verstellbares oberes Torband mit L-Platte
Bisagra superior regulable con placa en L
Верхняя регулируемая петля с пластиной в форме L



CODE	ART.	Size	A	B	C	D	H	I	L	N	R	S	Portata Capacity	Box info	
														Pcs per pack	Kg
10801607 001	85L-M	Medio Ø50	50	90	9	Ø25	62	45	100	Ø48	70-85	10	350 kg	2	2,4
10801610 001	85L-G	Grande Ø70	60	110	15	Ø35	72	55	130	Ø68	90-105	10	500 kg	2	4,1

Finishing: Zincato / Galvanized

Categoria commerciale: 1A

La portata è riferita ad una coppia di cardini nel caso di peso uniformemente distribuito in un'anta con L=H.
Weight bearing capacity refers to a pair of hinges mounted on a gate with weight uniformly distributed on a leaf with proportions L=H.

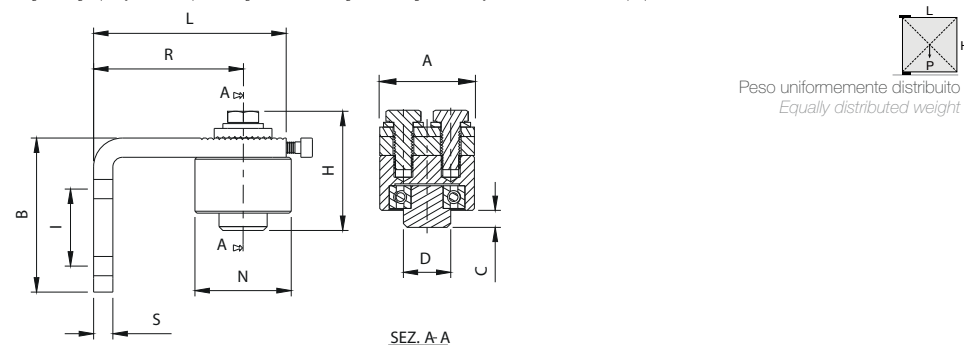

85PST

Cardine superiore regolabile con piastra a fissare

Adjustable upper hinge with plate to be screwed
Gond supérieur réglable avec platine à visser
Verstellbares oberes Torband mit Platte zum Anschrauben
Bisagra superior regulable con placa para fijar
Верхняя регулируемая петля с прикрепляемой пластиной

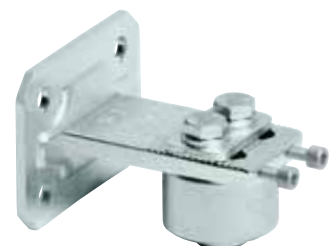

CODE	ART.	Size	A	C	D	H	L	N	R	Portata Capacity	Box info	
											Pcs per pack	Kg
10801407 001	85PST-M	Medio Ø50	50	9	Ø25	62	100	Ø48	70-85	350 kg	2	2,3
10801410 001	85PST-G	Grande Ø70	60	15	Ø35	72	130	Ø68	90-105	500 kg	2	3,2

Finishing: Zincato / Galvanized

Categoria commerciale: 1A

La portata è riferita ad una coppia di cardini nel caso di peso uniformemente distribuito in un'anta con L=H.
Weight bearing capacity refers to a pair of hinges mounted on a gate with weight uniformly distributed on a leaf with proportions L=H.

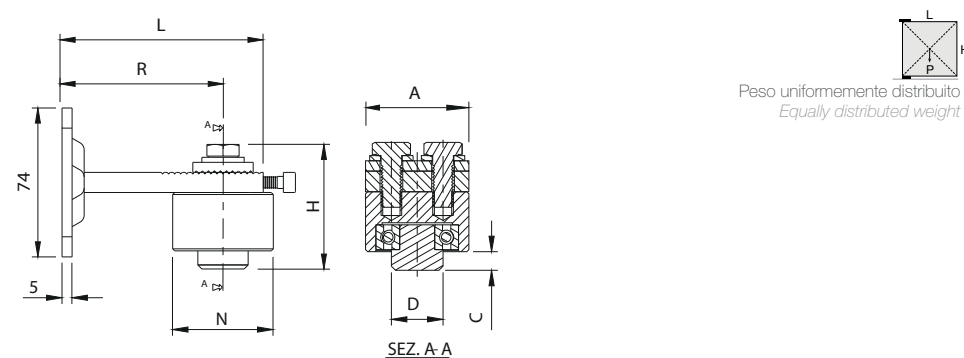

86P

Cardine superiore con cuscinetto e piastra

Upper hinge with plate
Gond supérieur avec platine
Oberes Torband mit Platte
Bisagra superior con rodamiento y placa
Верхняя петля с подшипником и пластиной



CODE	ART.	Size	R	Portata Capacity	Box info	
					Pcs per pack	Kg
10800505 001	86P	Piccolo Ø47	50-60	200 kg	4	2,5

Finishing: Zincato / Galvanized

Categoria commerciale: 1A

La portata è riferita ad una coppia di cardini nel caso di peso uniformemente distribuito in un'anta con L=H.
Weight bearing capacity refers to a pair of hinges mounted on a gate with weight uniformly distributed on a leaf with proportions L=H.

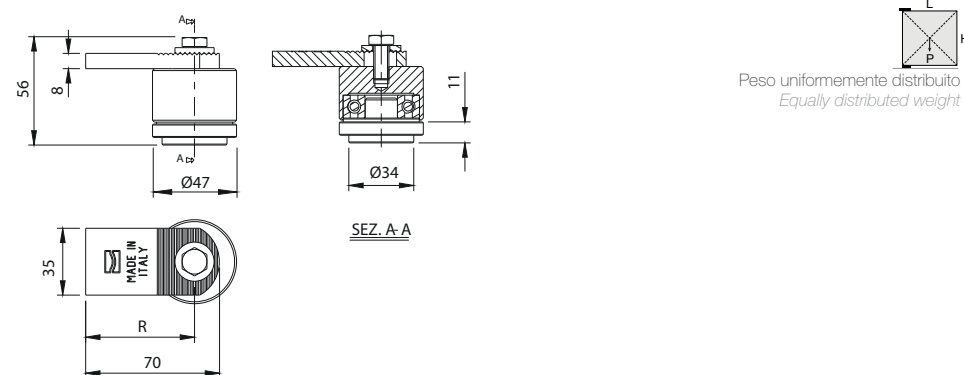

86i-P

Cardine superiore con piastra

Upper hinge with plate
Gond supérieur avec platine
Oberes Torband mit Platte
Bisagra superior con placa
Верхняя петля с пластиной



CODE	ART.	Size	R	Portata Capacity	Box info	
					Pcs per pack	Kg
10800605	86i-P	Piccolo Ø 50	50-60	200 kg	2	1,7

Finishing: Inox / Stainless steel (cuscinetto in acciaio / steel bearing)

Categoria commerciale: 2A

La portata è riferita ad una coppia di cardini nel caso di peso uniformemente distribuito in un'anta con L=H.
Weight bearing capacity refers to a pair of hinges mounted on a gate with weight uniformly distributed on a leaf with proportions L=H.

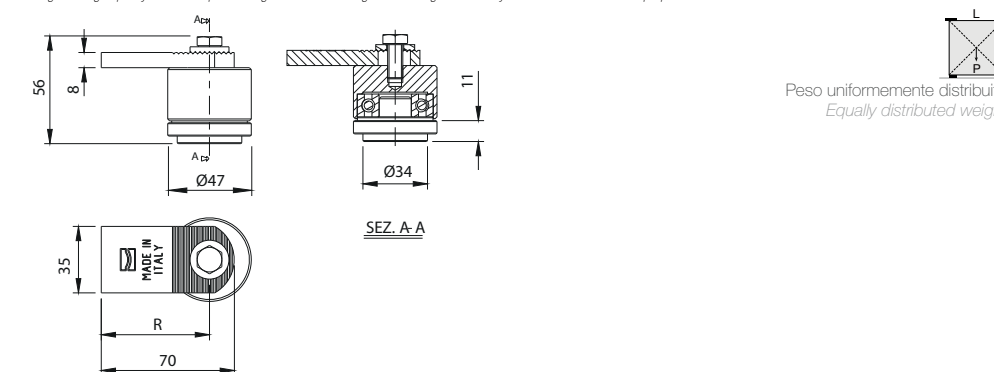

86G

Cardine superiore con piastra

Upper hinge with plate
Gond supérieur avec platine
Oberes Torband mit Platte
Bisagra superior con placa
Верхняя петля с пластиной



CODE	ART.	Size	R	Portata Capacity	Box info	
					Pcs per pack	Kg
10800510 001	86G	Grande Ø70	90-105	650 kg	2	3,2

Finishing: Zincato / Galvanized

Categoria commerciale: 1A

La portata è riferita ad una coppia di cardini nel caso di peso uniformemente distribuito in un'anta con L=H.
Weight bearing capacity refers to a pair of hinges mounted on a gate with weight uniformly distributed on a leaf with proportions L=H.

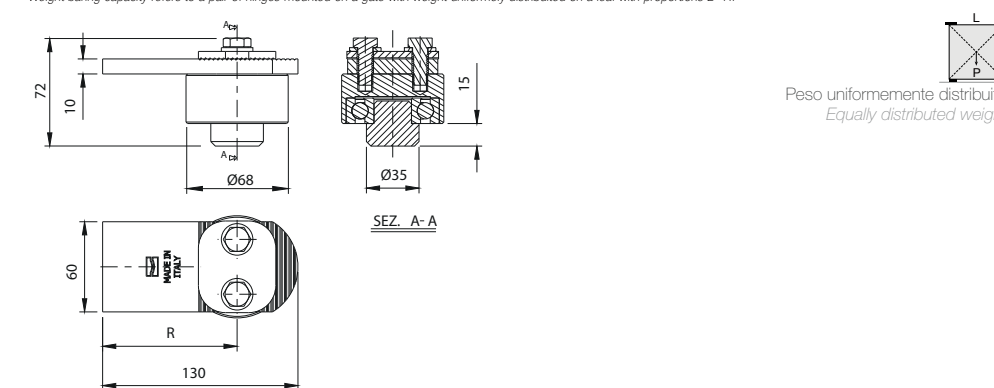

86i-G

Cardine superiore con piastra

Upper hinge with plate
Gond supérieur avec platine
Oberes Torband mit Platte
Bisagra superior con placa
Верхняя петля с пластиной



CODE	ART.	Size	R	Portata Capacity	Box info	
					Pcs per pack	Kg
10800610	86i-G	Grande Ø70	90-105	650 kg	2	4,1

Finishing: Inox / Stainless steel (cuscinetto in acciaio / steel bearing)

Categoria commerciale: 2A

La portata è riferita ad una coppia di cardini nel caso di peso uniformemente distribuito in un'anta con L=H.
Weight bearing capacity refers to a pair of hinges mounted on a gate with weight uniformly distributed on a leaf with proportions L=H.

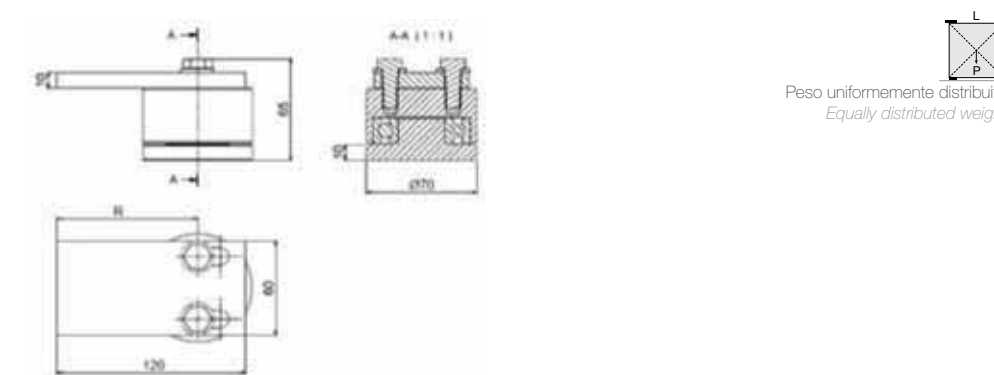



86L-P

Cardine superiore con piastra a L
Upper hinge with L plate
Gond supérieur avec platine à L
Oberes Torband mit L-Platte
Bisagra superior con placa en L
Верхняя петля с пластиной в форме L



CODE	ART.	Size	R	Portata Capacity	Box info	
					Pcs per pack	Kg
10801805 001	86L-P	Piccolo Ø 47	50-80	200 kg	2	1,9

Finishing: Zincato / Galvanized

Categoria commerciale: 1A

La portata è riferita ad una coppia di cardini nel caso di peso uniformemente distribuito in un'anta con L=H.
Weight bearing capacity refers to a pair of hinges mounted on a gate with weight uniformly distributed on a leaf with proportions L=H.

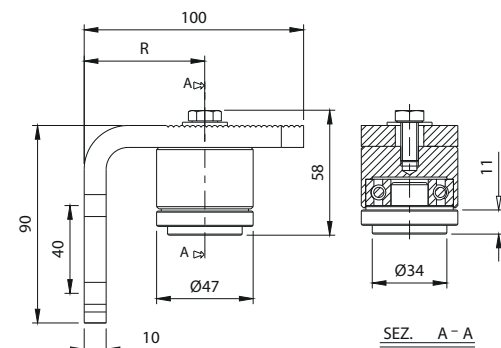

87P

Cardine inferiore con cuscinetto reggi spinta
Bottom hinge with thrust bearing
Gond inférieur avec roulement de butée
Unteres Torband mit Drucklager
Bisagra inferior con rodamiento de empuje
Нижняя петля с упорным подшипником



CODE	ART.	Size	Portata Capacity	Box info	
				Pcs per pack	Kg
10801005 001	87P	Piccolo Ø 47	200 kg	4	1,6

Finishing: Zincato / Galvanized

Categoria commerciale: 1A

La portata è riferita ad una coppia di cardini nel caso di peso uniformemente distribuito in un'anta con L=H.
Weight bearing capacity refers to a pair of hinges mounted on a gate with weight uniformly distributed on a leaf with proportions L=H.

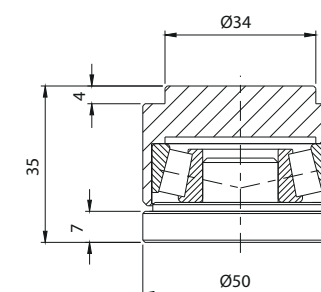

86L-G

Cardine superiore con piastra a L
Upper hinge with L plate
Gond supérieur avec platine à L
Oberes Torband mit L-Platte
Bisagra superior con placa en L
Верхняя петля с пластиной в форме L



CODE	ART.	Size	R	Portata Capacity	Box info	
					Pcs per pack	Kg
10801810 001	86L-G	Grande Ø70	90-105	500 kg	2	4,1

Finishing: Zincato / Galvanized

Categoria commerciale: 1A

La portata è riferita ad una coppia di cardini nel caso di peso uniformemente distribuito in un'anta con L=H.
Weight bearing capacity refers to a pair of hinges mounted on a gate with weight uniformly distributed on a leaf with proportions L=H.

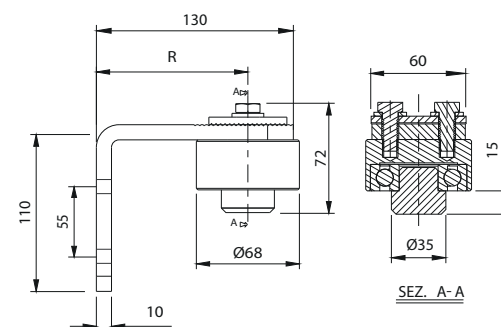

87i-P 87i-G

Cardine inferiore con cuscinetto reggi spinta
Bottom hinge with thrust bearing
Gond inférieur avec roulement de butée
Unteres Torband mit Drucklager
Bisagra superior con placa
Верхняя петля с пластиной



CODE	ART.	Size	C	D	H	Portata Capacity	Box info	
							Pcs per pack	Kg
10801105	87i-P	Piccolo Ø50	200 kg	2	1,0			
10801110	87i-G	Grande Ø 70	8	Ø70	40	650 kg	2	2,0

Finishing: Inox / Stainless steel

Categoria commerciale: 2A

La portata è riferita ad una coppia di cardini nel caso di peso uniformemente distribuito in un'anta con L=H.
Weight bearing capacity refers to a pair of hinges mounted on a gate with weight uniformly distributed on a leaf with proportions L=H.

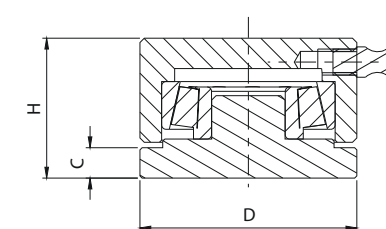

86PST

Cardine superiore con piastra a fissare
Upper hinge with plate to be screwed
Gond supérieur avec platine à visser
Oberes Torband mit Platte zum Anschrauben
Bisagra superior con placa para fijar
Верхняя петля с прикрепляемой пластиной



CODE	ART.	Size	R	Portata Capacity	Box info	
					Pcs per pack	Kg
10801710 001	86PST	Grande Ø70	90-105	500 kg	2	3,8

Finishing: Zincato / Galvanized

Categoria commerciale: 1A

La portata è riferita ad una coppia di cardini nel caso di peso uniformemente distribuito in un'anta con L=H.
Weight bearing capacity refers to a pair of hinges mounted on a gate with weight uniformly distributed on a leaf with proportions L=H.

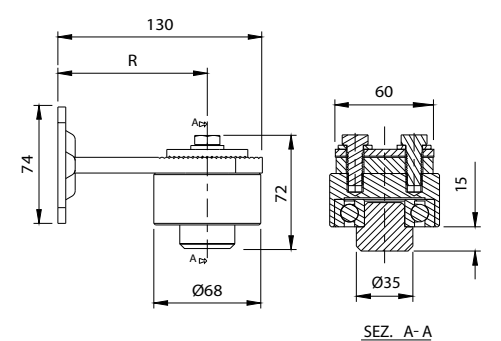



87

Cardine inferiore con cuscinetto reggi spinta

Bottom hinge with thrust bearing
Gond inférieur avec roulement de butée
Unteres Torband mit Drucklager
Bisagra inferior con rodamiento de empuje
Нижняя петля с упорным подшипником



CODE	ART.	Size	C	D	H	Portata Capacity	Box info	
							Pcs per pack	Kg
10801007 001	87M	Medio Ø50	8	Ø49	32	450 kg	4	1,8
10801010 001	87G	Grande Ø70	8	Ø68	40	650 kg	2	2,0

Finishing: Zincato / Galvanized

Categoria commerciale: 1A

La portata è riferita ad una coppia di cardini nel caso di peso uniformemente distribuito in un'anta con L=H.
Weight bearing capacity refers to a pair of hinges mounted on a gate with weight uniformly distributed on a leaf with proportions L=H.

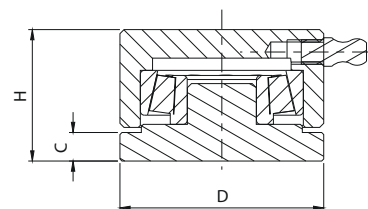

84i

Cardine inferiore con perno sferico

Bottom plate with spherical pin
Platine inférieur et pivot sphérique
Bodenplatte mit Drehstift
Base inferior con perno con bola
Нижняя плита со сферическим штифтом



CODE	ART.	Size	Portata Capacity	Box info	
				Pcs per pack	Kg
10800305	84i	42x42	100 kg	2	1,3

Finishing: Inox / Stainless steel

Categoria commerciale: 2A

La portata è riferita ad una coppia di cardini nel caso di peso uniformemente distribuito in un'anta con L=H.
Weight bearing capacity refers to a pair of hinges mounted on a gate with weight uniformly distributed on a leaf with proportions L=H.

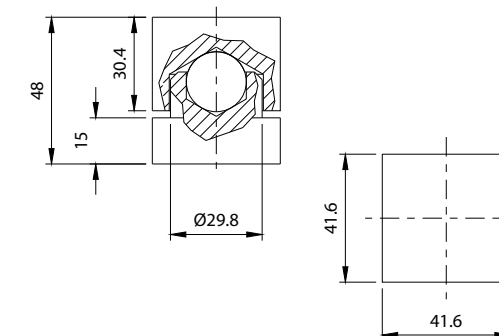

87L-P

Cardine inferiore con cuscinetto reggi spinta e piastra a L

Bottom hinge with thrust bearing and L plate
Gond inférieur avec roulement de butée et platine à L
Unteres Torband mit Drucklager und L-Platte
Bisagra inferior con rodamiento de empuje y placa en L
Нижняя петля с упорным подшипником и пластиной в форме L



CODE	ART.	Size	R	Portata Capacity	Box info	
					Pcs per pack	Kg
10801305 001	87L-P	Piccolo Ø47	50-80	200 kg	4	2,9

Finishing: Zincato / Galvanized

Categoria commerciale: 1A

La portata è riferita ad una coppia di cardini nel caso di peso uniformemente distribuito in un'anta con L=H.
Weight bearing capacity refers to a pair of hinges mounted on a gate with weight uniformly distributed on a leaf with proportions L=H.

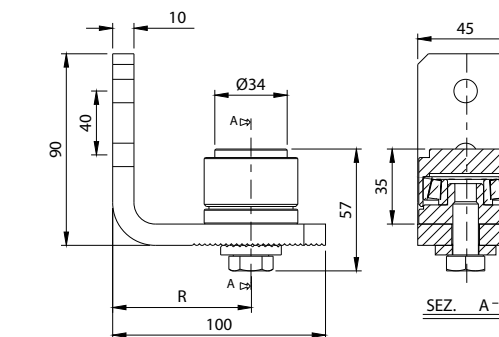

87PST-P

Cardine inferiore con cuscinetto reggi spinta e piastra a fissare

Bottom hinge with thrust bearing and plate to be screwed
Gond inférieur avec roulement de butée et platine à fixer
Unteres Torband mit Drucklager und Platte zum Anschrauben
Bisagra inferior con rodamiento de empuje y placa para fijar
Нижняя петля с упорным подшипником и прикрепляемой пластиной



CODE	ART.	Size	R	Portata Capacity	Box info	
					Pcs per pack	Kg
10801205 001	87PST-P	Piccolo Ø 47	10	200 kg	2	1,2

Finishing: Zincato / Galvanized

Categoria commerciale: 1A

La portata è riferita ad una coppia di cardini nel caso di peso uniformemente distribuito in un'anta con L=H.
Weight bearing capacity refers to a pair of hinges mounted on a gate with weight uniformly distributed on a leaf with proportions L=H.

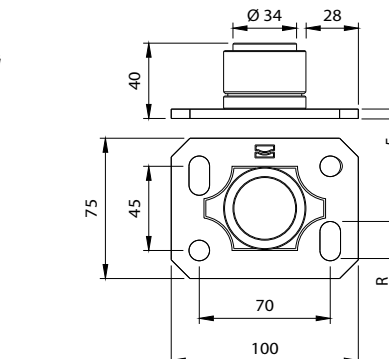

Mounting instructions art. 87



87L

Cardine inferiore con cuscinetto reggi spinta e piastra a L

Bottom hinge with thrust bearing and L plate

Gond inférieur avec roulement de butée et platine à L

Unteres Torband mit Drucklager und L-Platte

Bisagra inferior con rodamiento de empuje y placa en L

Нижняя петля с упорным подшипником и пластиной в форме L



CODE	ART.	Size	A	C	D	H	I	L	R	Portata Capacity	Box info	
											Pcs per pack	Kg
10801307 001	87L-M	Medio Ø50	45	90	Ø 49	52	40	100	55-85	350 kg	4	4,0
10801310 001	87L-G	Grande Ø70	60	110	Ø 68	66	55	130	95-105	500 kg	2	4,2

Finishing: Zincato / Galvanized

Categoria commerciale: 1A

La portata è riferita ad una coppia di cardini nel caso di peso uniformemente distribuito in un'anta con L=H.
Weight bearing capacity refers to a pair of hinges mounted on a gate with weight uniformly distributed on a leaf with proportions L=H.

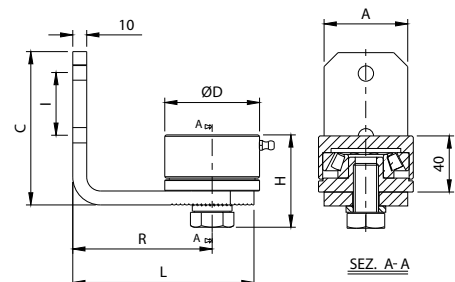

87PST

Cardine inferiore con cuscinetto reggi spinta e piastra a fissare

Bottom hinge with thrust bearing and plate to be screwed

Gond inférieur avec roulement de butée et platine à fixer

Unteres Torband mit Drucklager und Platte zum Anschrauben

Bisagra inferior con rodamiento de empuje y placa para fijar

Нижняя петля с упорным подшипником и прикрепляемой пластиной



CODE	ART.	Size	A	B	D	E	I	R	Portata Capacity	Box info	
										Pcs per pack	Kg
10801207 001	87PST-M	Medio Ø 50	75	100	Ø 49	25	70	10	350 kg	2	1,2
10801210 001	87PST-G	Grande Ø 70	75	135	Ø 68	33,5	105	10	500 kg	2	2,5

Finishing: Zincato / Galvanized

Categoria commerciale: 1A

La portata è riferita ad una coppia di cardini nel caso di peso uniformemente distribuito in un'anta con L=H.
Weight bearing capacity refers to a pair of hinges mounted on a gate with weight uniformly distributed on a leaf with proportions L=H.

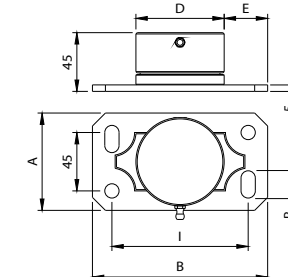

Mounting instructions art. 87L

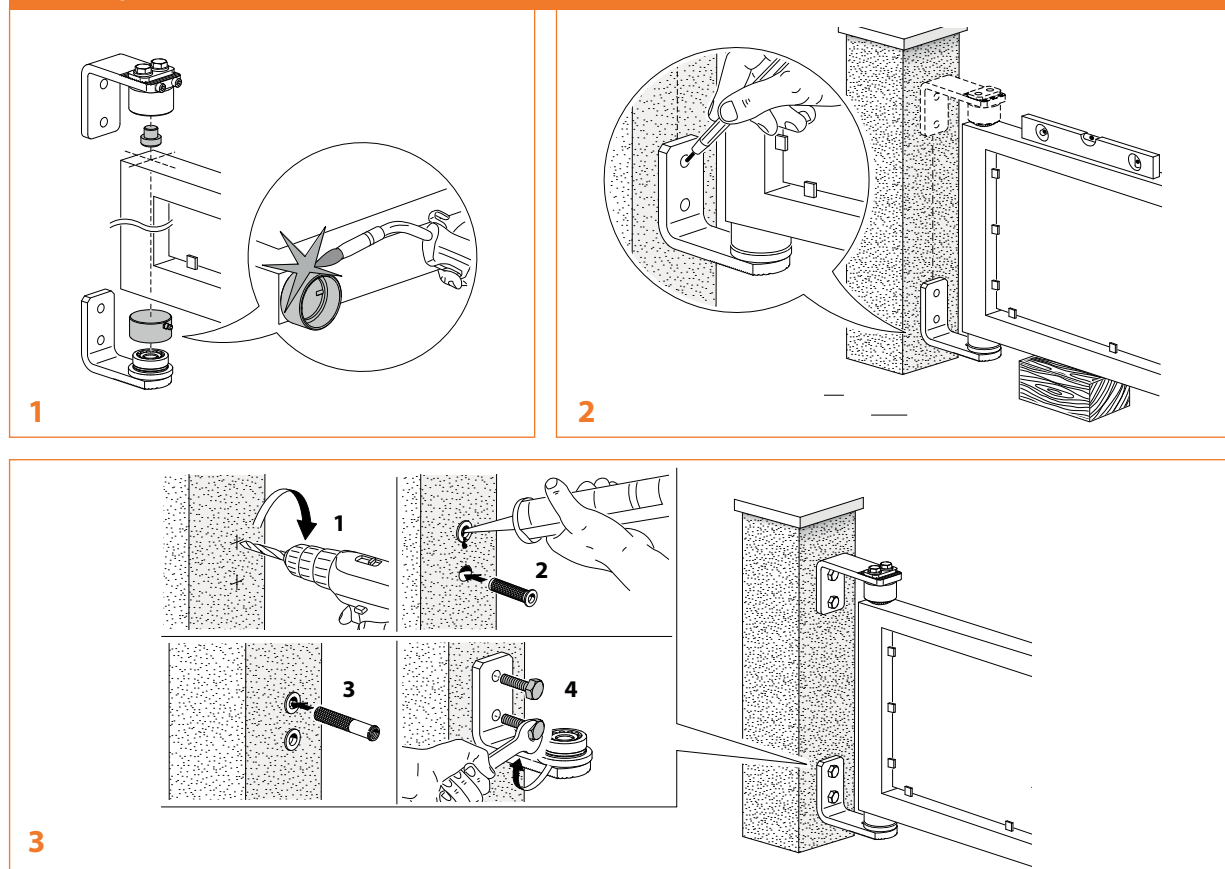

Mounting instructions art. 87PST

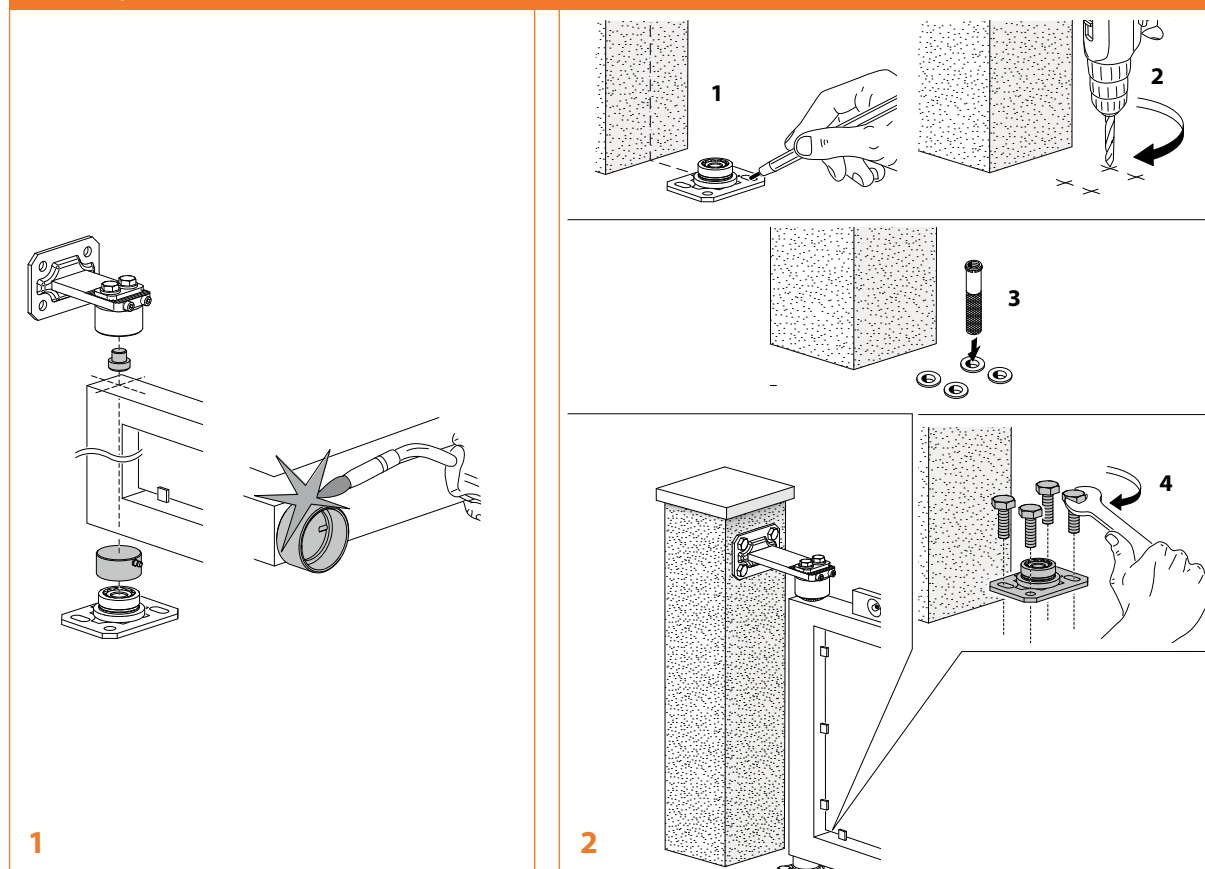



87XL

Cardine inferiore pesante con cuscinetto reggi spinta e piastra a fissare

Heavy bottom hinge with thrust bearing and plate to be screwed
Gond inférieur lourd avec roulement de butée et platine à visser
Schweres oberes Torband mit Drucklager und Platte zum Anschrauben

Bisagra inferior pesada con rodamiento de empuje y placa
Тяжелая нижняя петля с упорным подшипником и пластиной



CODE	ART.	R	Portata Capacity	Box info	
				Pcs per pack	Kg
10801011 001	87XL	10	4000 kg	1	5,5

Finishing: Zincato / Galvanized

La portata è riferita ad una coppia di cardini nel caso di peso uniformemente distribuito in un'anta con L=H.
Weight bearing capacity refers to a pair of hinges mounted on a gate with weight uniformly distributed on a leaf with proportions L=H.

Categoria commerciale: 1A

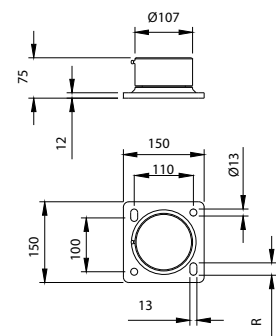

Peso uniformemente distribuito
Equally distributed weight

88

Cardine superiore perno quadro piastra a saldare

Upper hinge with square pin and plate to be welded
Gond supérieur avec pivot carré et platine à souder
Oberes Torband mit viereckigem Stift und Platte zum Schweißen

Bisagra superior pernio cuadrado placa para soldar
Верхняя регулируемая петля квадратный штифт с привариваемой пластиной



CODE	ART.	B	C	D	H	N	R	Portata Capacity	Box info	
									Pcs per pack	Kg
10801505 001	88-40	40	10	Ø33	87	59	90-105	200 kg	2	3,2
10801510 001	88-50	50	10	Ø43	87	59	90-105	450 kg	2	3,5
10801515 001	88-60	60	15	Ø52	92	68	90-105	650 kg	2	4,5

Finishing: Zincato / Galvanized

La portata è riferita ad una coppia di cardini nel caso di peso uniformemente distribuito in un'anta con L=H.
Weight bearing capacity refers to a pair of hinges mounted on a gate with weight uniformly distributed on a leaf with proportions L=H.

Categoria commerciale: 1A

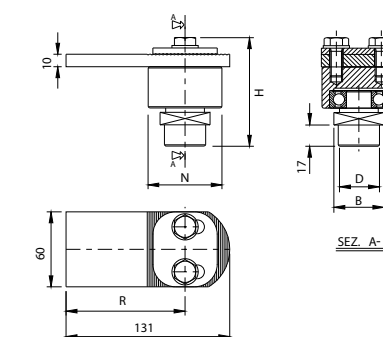

Peso uniformemente distribuito
Equally distributed weight

Mounting instructions art. 87XL

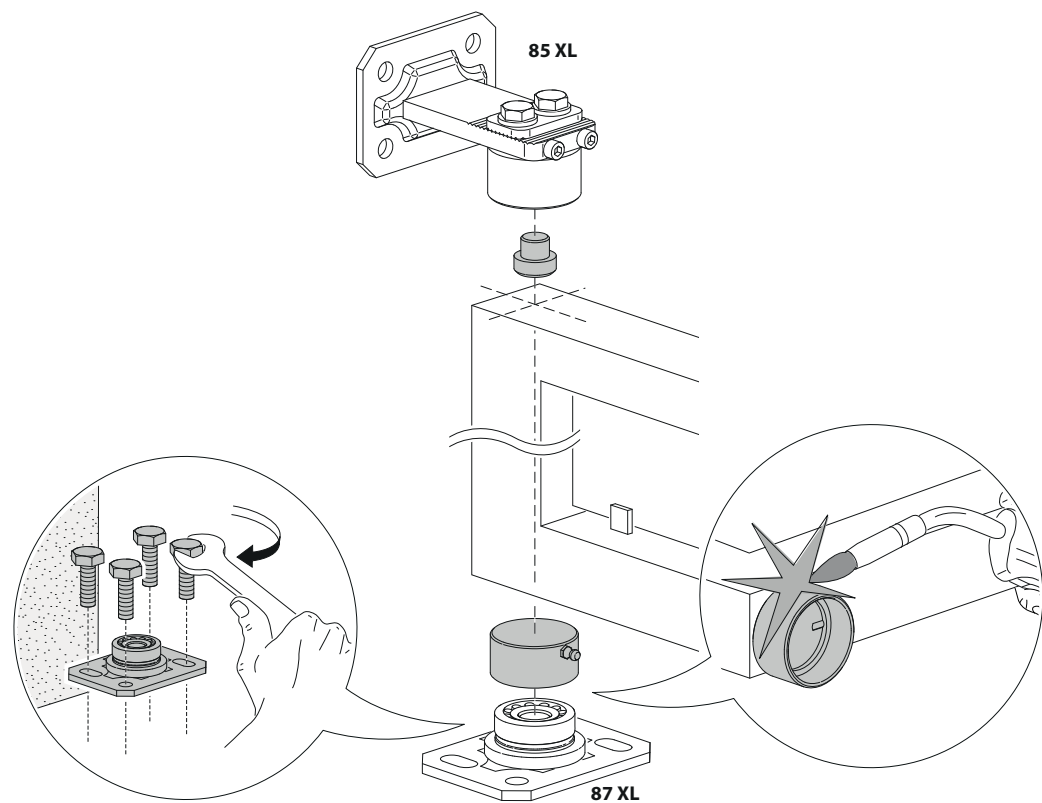

Mounting instructions art. 88

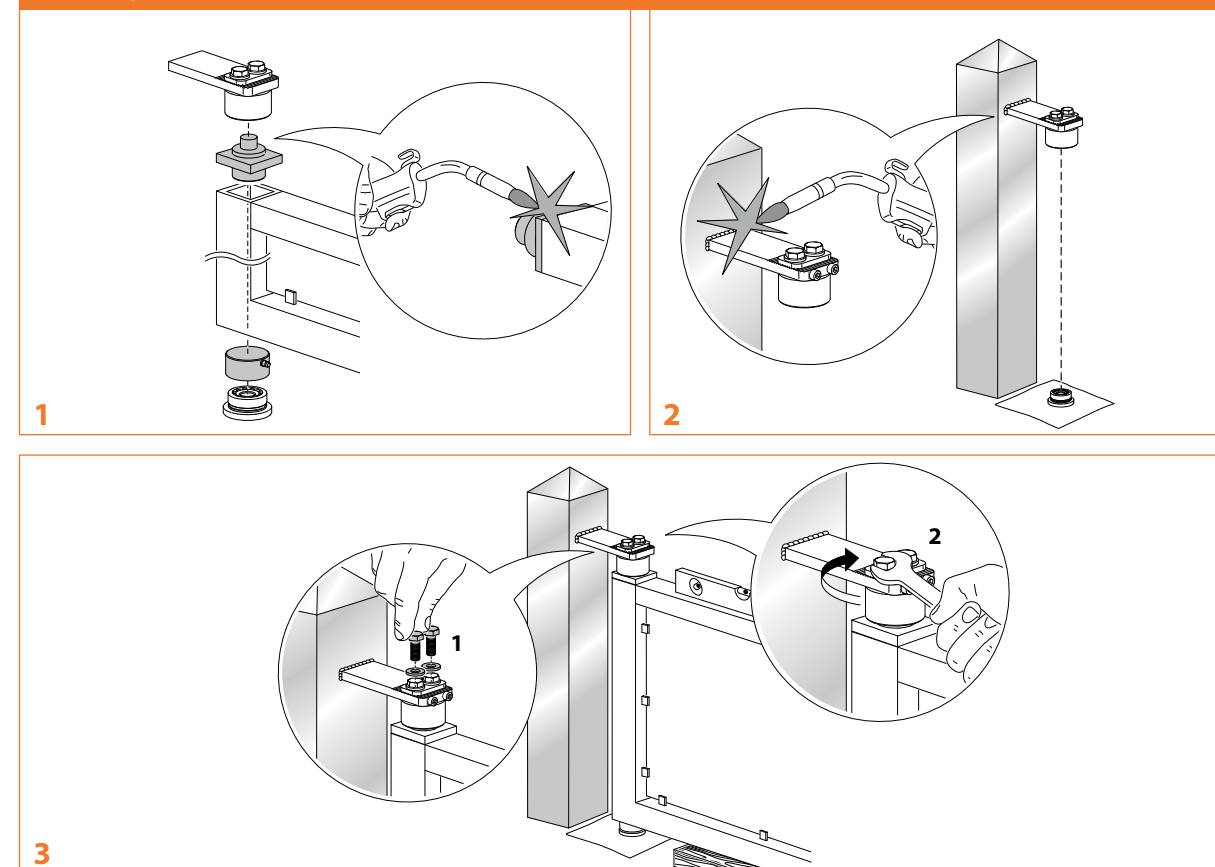



88L

Cardine superiore perno quadro
piastra a fissare a L

Upper hinge with square pin and L plate to be screwed
Gond supérieur avec pivot carré et platine à L
Oberes Torband mit viereckigem Stift und L-Platte zum
Anschrauben
Bisagra superior pernio cuadrado placa en L para fijar
Верхняя регулируемая петля квадратный штифт с
прикрепляемой пластиной в форме L



CODE	ART.	B	C	D	H	N	R	Portata Capacity	Box info	
									Pcs per pack	Kg
10802105 001	88L-40	40	10	Ø 33	87	59	90-105	200 kg	2	3,8
10802110 001	88L-50	50	10	Ø 43	87	59	90-105	350 kg	2	4,1
10802115 001	88L-60	60	15	Ø 52	92	68	90-105	500 kg	2	4,7

Finishing: Zincato / Galvanized

Categoria commerciale: 1A

La portata è riferita ad una coppia di cardini nel caso di peso uniformemente distribuito in un'anta con L=H.
Weight bearing capacity refers to a pair of hinges mounted on a gate with weight uniformly distributed on a leaf with proportions L=H.

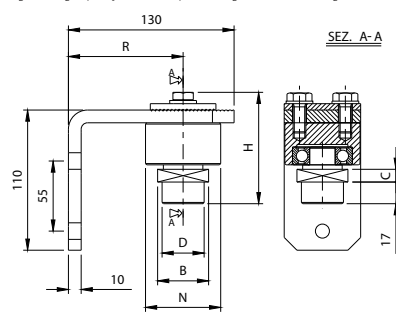

Peso uniformemente distribuito
Equally distributed weight



88PST

Cardine superiore perno quadro
piastra a fissare

Upper hinge with square pin and plate to be screwed
Gond supérieur avec pivot carré et platine à visser
Oberes Torband mit viereckigem Stift und Platte zum
Anschrauben
Bisagra superior pernio cuadrado placa en L para fijar
Верхняя регулируемая петля квадратный штифт с
прикрепляемой пластиной в форме L



CODE	ART.	B	C	D	H	N	R	Portata Capacity	Box info	
									Pcs per pack	Kg
10802205 001	88PST-40	40	10	Ø 33	87	59	90-105	200 kg	2	3,6
10802210 001	88PST-50	50	10	Ø 43	87	59	90-105	350 kg	2	3,9
10802215 001	88PST-60	60	15	Ø 52	92	68	90-105	500 kg	2	4,9

Finishing: Zincato / Galvanized

Categoria commerciale: 1A

La portata è riferita ad una coppia di cardini nel caso di peso uniformemente distribuito in un'anta con L=H.
Weight bearing capacity refers to a pair of hinges mounted on a gate with weight uniformly distributed on a leaf with proportions L=H.

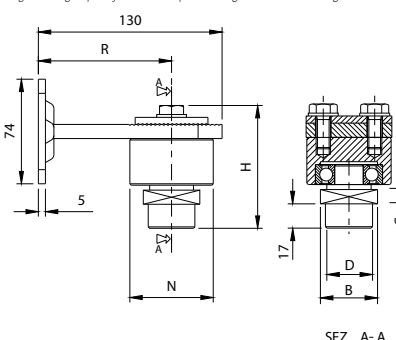

Peso uniformemente distribuito
Equally distributed weight



89

Maxiperno inferiore con cuscinetto

Bottom big pin with bearing
Pivot grand inférieur avec roulement
Unterer Maxibolzen mit Kugellager
Maxi-pernio inferior con cojinete
Нижний увеличенный штифт с подшипником



CODE	ART.	Size	A	D	Portata Capacity	Box info	
						Pcs per pack	Kg
10802005	89-40	Ø 40	Ø 59	Ø 33	200 kg	2	2,6
10802010	89-50	Ø 50	Ø 59	Ø 43	450 kg	2	2,8
10802015	89-60	Ø 60	Ø 64	Ø 53	650 kg	2	3,4

Finishing: Non zincato / Not galvanized

Categoria commerciale: 1A

La portata è riferita ad una coppia di cardini nel caso di peso uniformemente distribuito in un'anta con L=H.
Weight bearing capacity refers to a pair of hinges mounted on a gate with weight uniformly distributed on a leaf with proportions L=H.

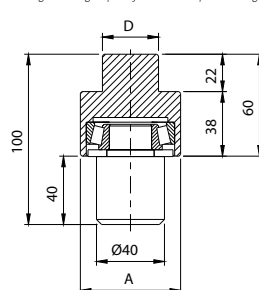

Peso uniformemente distribuito
Equally distributed weight

90

Cardine con ala cerniera

Hinge with wing
Gond avec aile paumelle
Torband mit Lasche
Bisagra con pernio pala
Петля с полкой шарнирного соединения



CODE	ART.	Size	A	C	H	M	N	R	Portata Capacity	Box info	
										Pcs per pack	Kg
10802505	90P	Piccolo	30	30	73	M10	43	55-65	200 kg	20	8,1
10802510	90G	Grande	35	49	95	M12	63	55-64	300 kg	10	6,1

Finishing: Non zincato / Not galvanized

Categoria commerciale: 1A

La portata è riferita ad una coppia di cardini nel caso di peso uniformemente distribuito in un'anta con L=H.
Weight bearing capacity refers to a pair of hinges mounted on a gate with weight uniformly distributed on a leaf with proportions L=H.

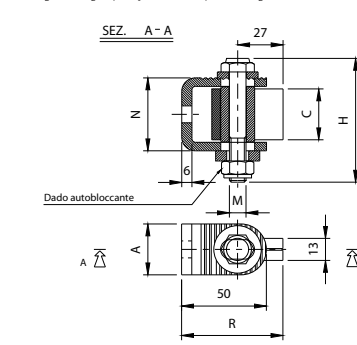

Peso uniformemente distribuito
Equally distributed weight

Mounting instructions art. 90

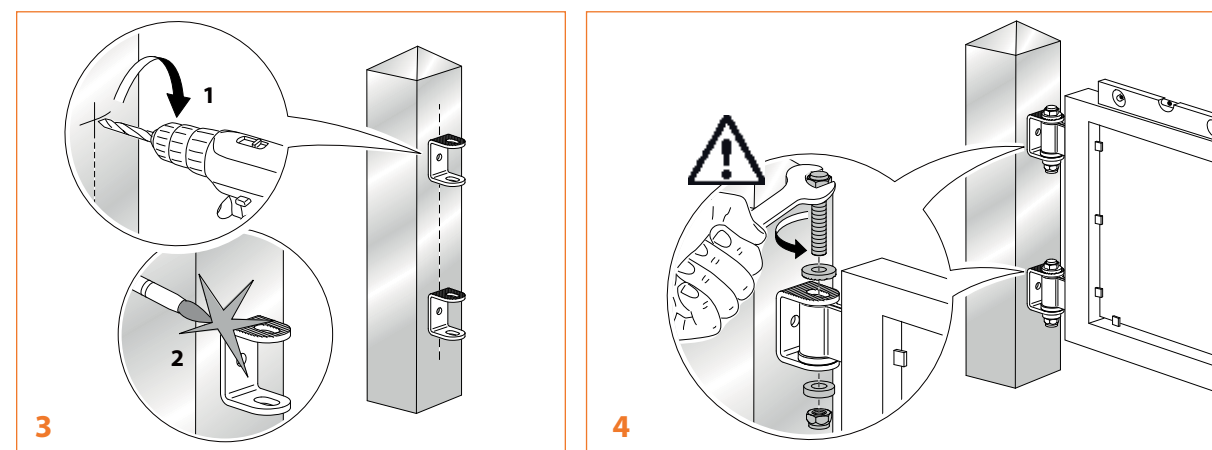
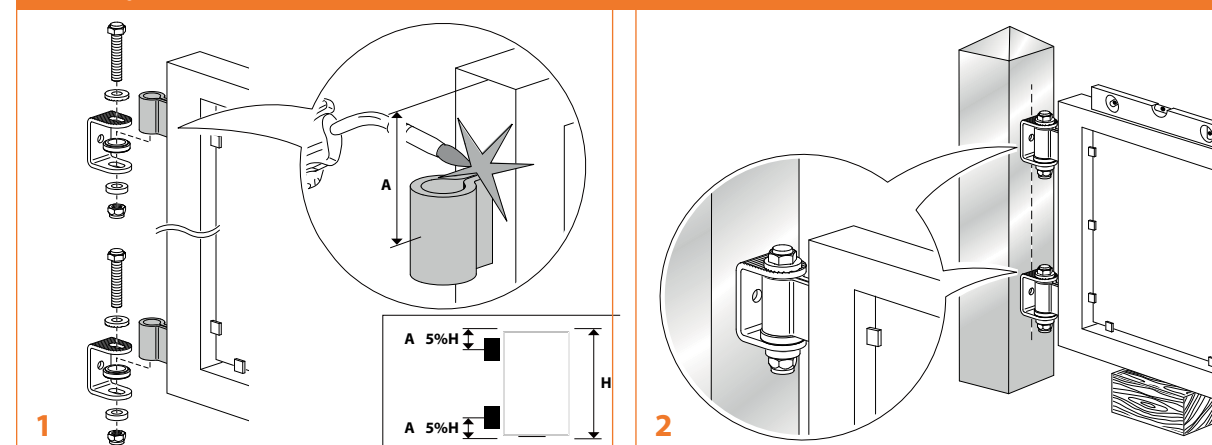



92G

Cardine con ala cerniera e cuscinetto
 Hinge with wing and bearing
 Gond avec aile paumelle et roulement
 Torband mit Lasche und Kugellager
 Bisagra con perno pala y rodamiento
 Петля с полкой шарнирного соединения и подшипником



CODE	ART.	Size	R	Portata Capacity	Box info	
					Pcs per pack	Kg
10803005	92G	Grande	54-64	300 kg	10	6,0

Finishing: Zincato / Galvanized

Categoria commerciale: 1A

La portata è riferita ad una coppia di cardini nel caso di peso uniformemente distribuito in un'anta con L=H.
 Weight bearing capacity refers to a pair of hinges mounted on a gate with weight uniformly distributed on a leaf with proportions L=H.

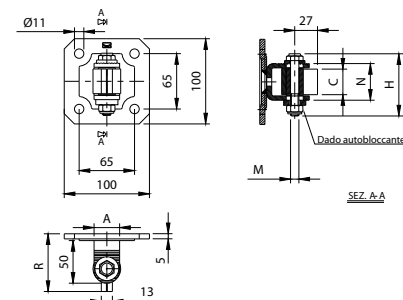

Peso uniformemente distribuito
 Equally distributed weight

94

Cardine ala cerniera con piastra a fissare
 Hinge with wing and plate to be screwed
 Gond avec aile paumelle et platine à visser
 Torband mit Lasche und Platte zum Anschrauben
 Bisagra con perno pala y placa para fijar
 Петля с полкой шарнирного соединения с прикрепляемой пластиной



CODE	ART.	Size	A	C	H	M	H	N	R	Portata Capacity	Box info	
											Pcs per pack	Kg
10803505 001	94P	Piccolo	30	30	73	22	M10	43	63-73	200 kg	20	15,5
10803510 001	94G	Grande	35	49	95	30	M12	63	62-72	300 kg	10	10,0

Finishing: Zincato / Galvanized

Categoria commerciale: 1A

La portata è riferita ad una coppia di cardini nel caso di peso uniformemente distribuito in un'anta con L=H.
 Weight bearing capacity refers to a pair of hinges mounted on a gate with weight uniformly distributed on a leaf with proportions L=H.

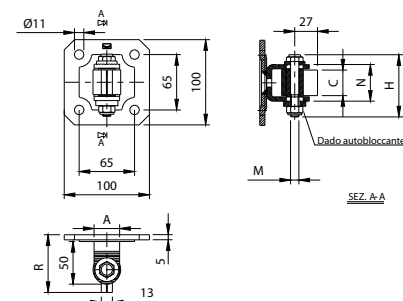

Peso uniformemente distribuito
 Equally distributed weight

96G

Cardine ala cerniera e cuscinetto con piastra a fissare
 Hinge with wing, bearing and plate to be screwed
 Gond avec aile paumelle et roulement avec platine à visser
 Torband mit Lasche, Kugellager und Platte zum Anschrauben
 Bisagra con perno pala y rodamiento con placa para fijar
 Петля с полкой шарнирного соединения и подшипником с прикрепляемой пластиной



CODE	ART.	Size	R	Portata Capacity	Box info	
					Pcs per pack	Kg
10804005 001	96G	Grande	62-72	300 kg	10	10,0

Finishing: Zincato / Galvanized

Categoria commerciale: 1A

La portata è riferita ad una coppia di cardini nel caso di peso uniformemente distribuito in un'anta con L=H.
 Weight bearing capacity refers to a pair of hinges mounted on a gate with weight uniformly distributed on a leaf with proportions L=H.

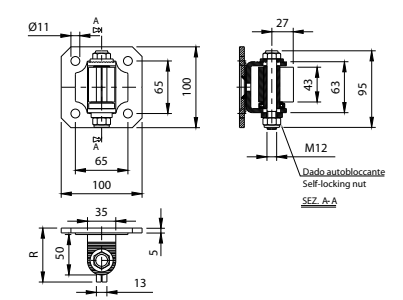

Peso uniformemente distribuito
 Equally distributed weight

100PST

Cardine con cavallotto e piastra a fissare
 Hinge with u bolt and plate to be screwed
 Gond avec crampillon et platine à visser
 Torband mit U-Bügel und Platte zum Anschrauben
 Bisagra con pletina en U y placa para fijar
 Петля со скобой и прикрепляемая пластина



CODE	ART.	Size	A	C	H	M	R	Portata Capacity	Box info	
									Pcs per pack	Kg
10804605 001	100PST-P	Piccolo	30	30	73	M10	64-74	100 kg	20	14,6
10804610 001	100PST-G	Grande	35	49	95	M12	62-72	200 kg	10	9,1

Finishing: Zincato / Galvanized

Categoria commerciale: 1A

La portata è riferita ad una coppia di cardini nel caso di peso uniformemente distribuito in un'anta con L=H.
 Weight bearing capacity refers to a pair of hinges mounted on a gate with weight uniformly distributed on a leaf with proportions L=H.

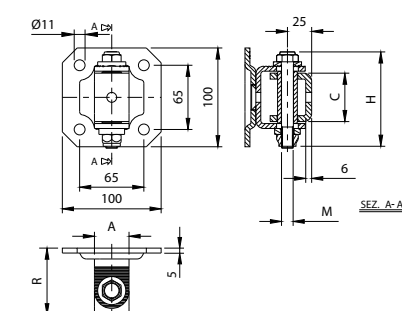

Peso uniformemente distribuito
 Equally distributed weight

105PST

Perno sferico e piastra a fissare
 Spherical pin and plate to be screwed
 Pivot sphérique et platine à visser
 Drehstift und Platte zum Anschrauben
 Perno con bola y placa para fijar
 Сферический штифт и прикрепляемая пластина



CODE	ART.	R	Portata Capacity	Box info	
				Pcs per pack	Kg
10805105 001	105PST	10	200 kg	5	4,5

Finishing: Zincato / Galvanized

Categoria commerciale: 1A

La portata è riferita ad una coppia di cardini nel caso di peso uniformemente distribuito in un'anta con L=H.
 Weight bearing capacity refers to a pair of hinges mounted on a gate with weight uniformly distributed on a leaf with proportions L=H.

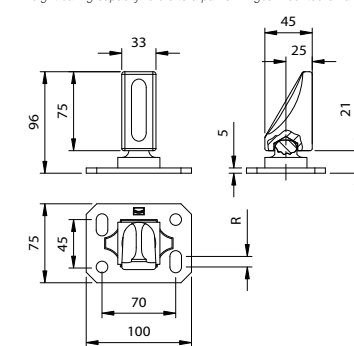

Peso uniformemente distribuito
 Equally distributed weight

106

Perno sferico e piastra regolabile
 Spherical pin and adjustable plate
 Pivot sphérique et platine réglable
 Kugelstift und verstellbare Platte
 Perno con bola y placa regulable
 Сферический штифт и регулируемая пластина



CODE	ART.	E	G	H	L	N	P	R	Portata Capacity	Box info		
										Pcs per pack	Kg	
10805205 001	106-20	33	25	124	75	49	45	50-70	32	150 kg	6	5,0
10805210 001	106-27	50	30	154	100	54	55	55-75	32	200 kg	2	3,0

Finishing: Zincato / Galvanized

Categoria commerciale: 1A

La portata è riferita ad una coppia di cardini nel caso di peso uniformemente distribuito in un'anta con L=H.
 Weight bearing capacity refers to a pair of hinges mounted on a gate with weight uniformly distributed on a leaf with proportions L=H.

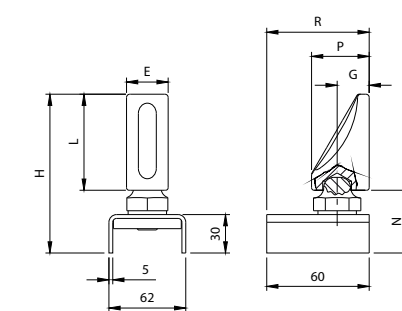

Peso uniformemente distribuito
 Equally distributed weight





100

Cardine con cavallotto
Hinge with U bolt
Gond avec crampillon
Torband mit U-Bügel
Bisagra con pletina en U
Петля со скобой



CODE	ART.	Size	A	C	H	M	N	R	Portata Capacity	Box info	
										Pcs per pack	Kg
10804505	100P	Piccolo	30	30	73	M10	43	53-63	100 kg	20	8,1
10804510	100G	Grande	35	49	95	M12	65	52-62	200 kg	10	6,1

Finishing: Non zincato / Not galvanized

Categoria commerciale: 1A

La portata è riferita ad una coppia di cardini nel caso di peso uniformemente distribuito in un'anta con L=H.
Weight bearing capacity refers to a pair of hinges mounted on a gate with weight uniformly distributed on a leaf with proportions L=H.

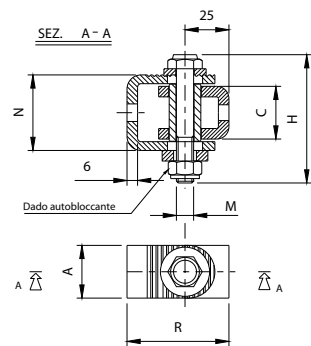

105

Perno sferico e piastra
Spherical pin and plate
Pivot sphérique et platine
Drehstift und Platte
Pernio con bola y placa
Сферический штифт и пластина



CODE	ART.	A	B	C	D	E	G	H	L	N	P	S	Portata con cardine superiore Capacity with top hinge	Box info	
														Pcs per pack	Kg
10805005	105-20	72	62	33	39	33	25	98	75	23	45	15	210 kg	10	8,5

Finishing: Zincato / Galvanized

Categoria commerciale: 1A

La portata è riferita ad una coppia di cardini nel caso di peso uniformemente distribuito in un'anta con L=H.
Weight bearing capacity refers to a pair of hinges mounted on a gate with weight uniformly distributed on a leaf with proportions L=H.

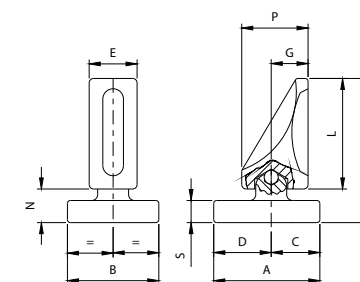

Mounting instructions art. 100

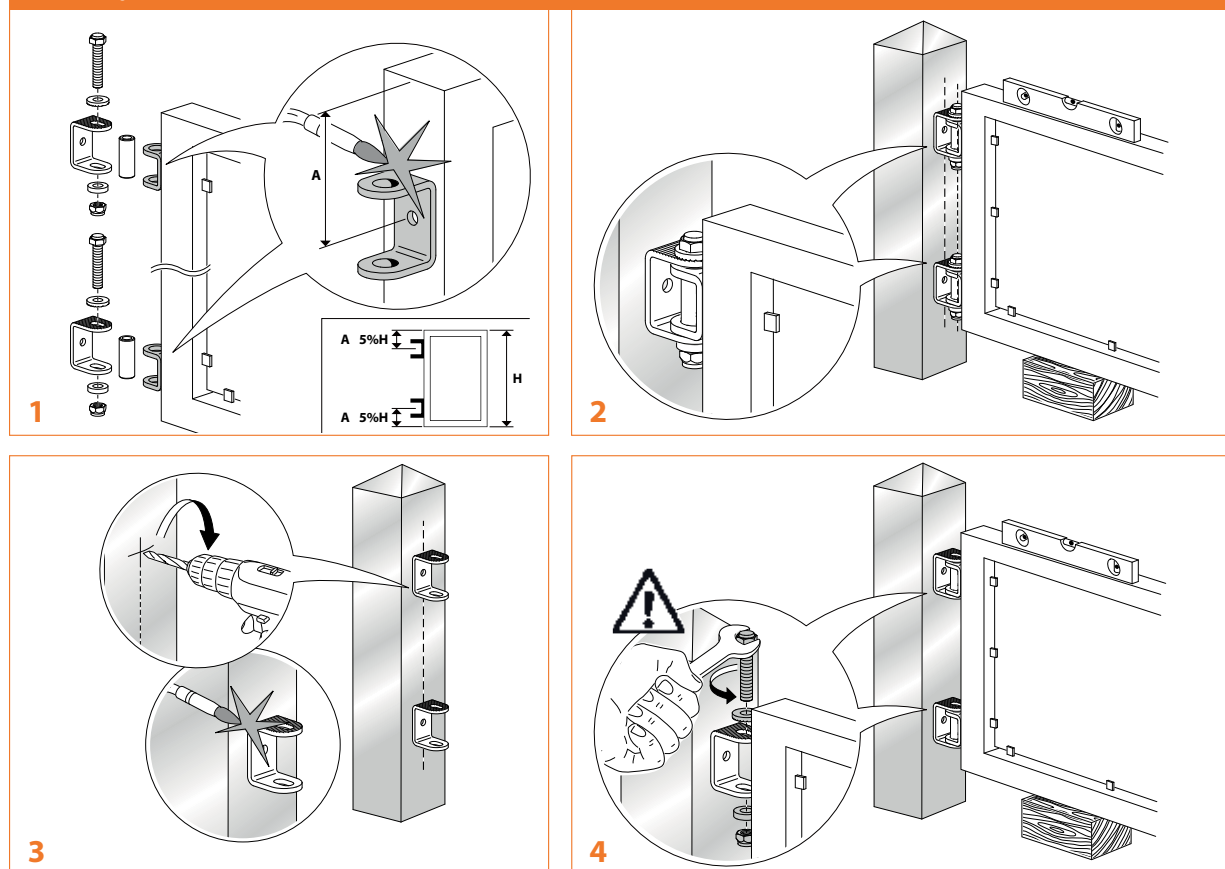

Mounting instructions art. 105

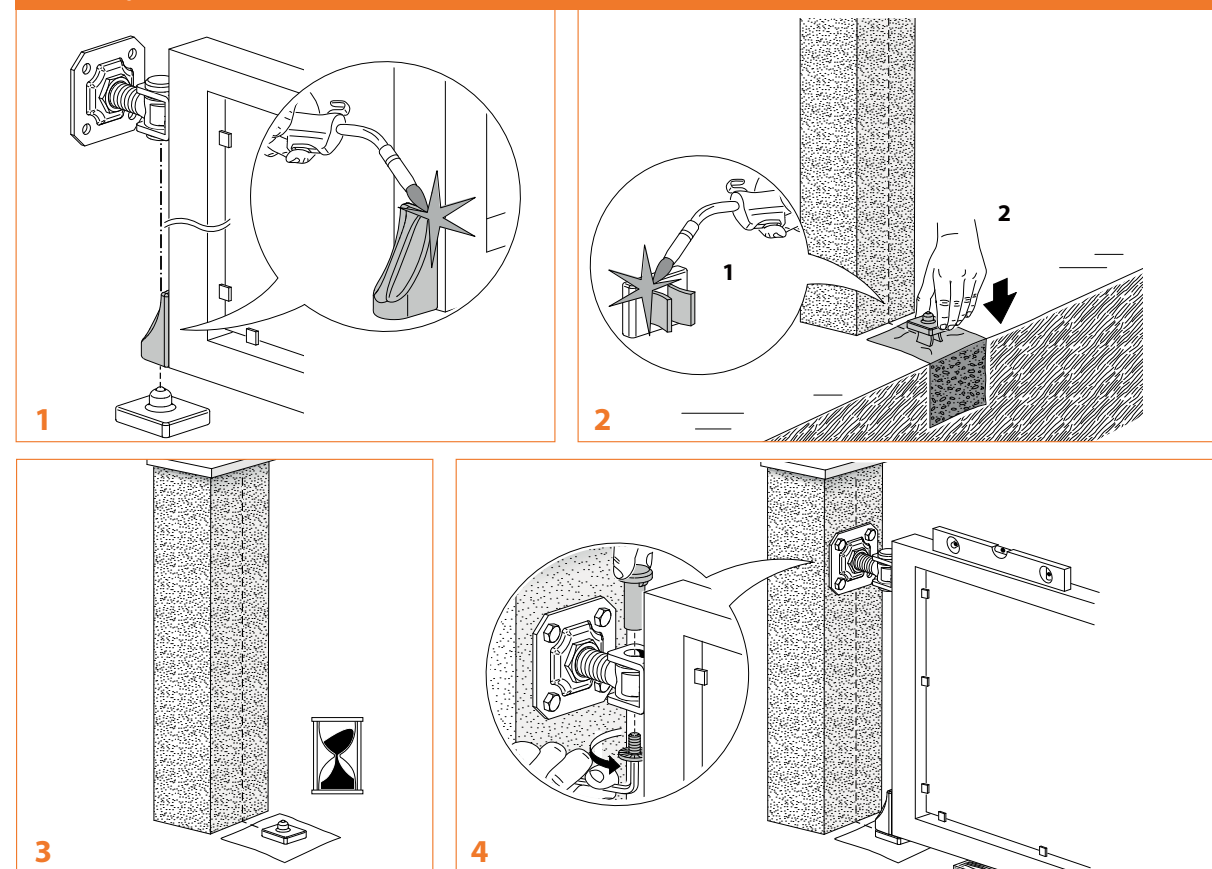



106PST

Perno sferico regolabile e piastra a fissare

Adjustable spherical pin and plate to be screwed
Pivot sphérique réglable et platine à visser
Verstellbarer Kugelstift und Platte zum Anschrauben
Perno con bola regulable y placa para fijar
Сферический регулируемый штифт и прикрепляемая пластина



CODE	ART.	E	G	H	L	N	P	R	Portata con cardine superiore Capacity with top hinge	Box info		
										Pcs per pack	Kg	
10805305 001	106PST-20	33	25	124	75	49	45	55-75	32	150 kg	2	2,4
10805310 001	106PST-27	50	30	154	100	54	55	70-90	32	200 kg	2	3,7

Finishing: Zincato / Galvanized

La portata è riferita ad una coppia di cardini nel caso di peso uniformemente distribuito in un'anta con L=H.
Weight bearing capacity refers to a pair of hinges mounted on a gate with weight uniformly distributed on a leaf with proportions L=H.

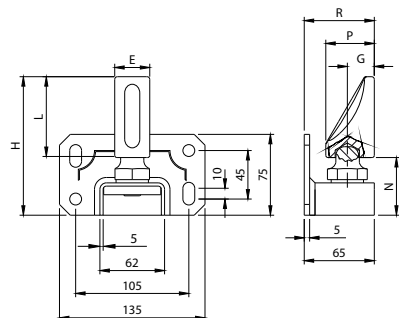

Categoria commerciale: 1A

110

Perno inferiore

Bottom pin
Pivot inférieur
Unterer Drehstift
Perno inferior
Нижний штифт

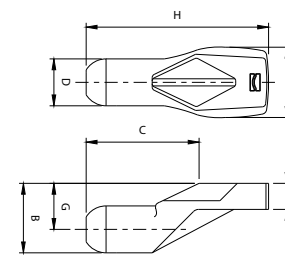

115

Piastra per perno inferiore

Plate for bottom pin
Platine pour pivot inférieur
Platte für unteren Drehstift
Placa para perno inferior
Пластина для нижнего штифта

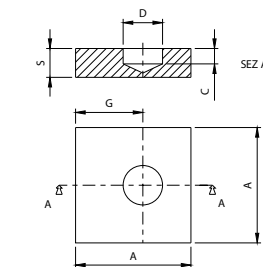

CODE	ART.	A	B	C	D	G	H	S	Portata con cardine superiore Capacity with top hinge	Box info	
										Pcs per pack	Kg
10805505	110-20	29	35	51	Ø 20	25	87	11	200 kg	20	4,1
10805510	110-24	35	39	65	Ø 24	27	99	13	300 kg	10	3,3
10805515	110-27	40	43	60	Ø 27	30	105	15	450 kg	10	4,6

Finishing: Non zincato / Not galvanized

Categoria commerciale: 1A

CODE	ART.	A	C	D	G	S	Box info	
							Pcs per pack	Kg
10806005	115-20,5	60	8	Ø 20,5	35	15	20	8,1
10806010	115-24,5	70	9	Ø 24,5	41	20	10	7,4
10806015	115-28	70	11	Ø 28	41	20	10	7,2

Finishing: Non zincato / Not galvanized

Categoria commerciale: 1A

La portata è riferita ad una coppia di cardini nel caso di peso uniformemente distribuito in un'anta con L=H.
Weight bearing capacity refers to a pair of hinges mounted on a gate with weight uniformly distributed on a leaf with proportions L=H.

Mounting instructions art. 106PST

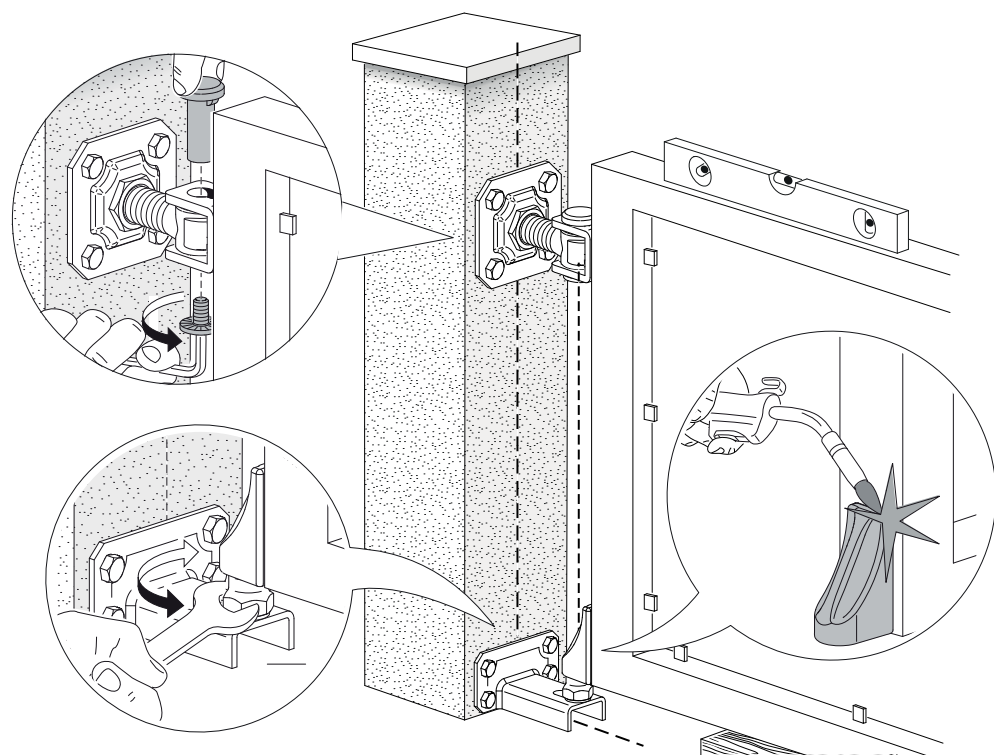

Mounting instructions art. 100 / 115

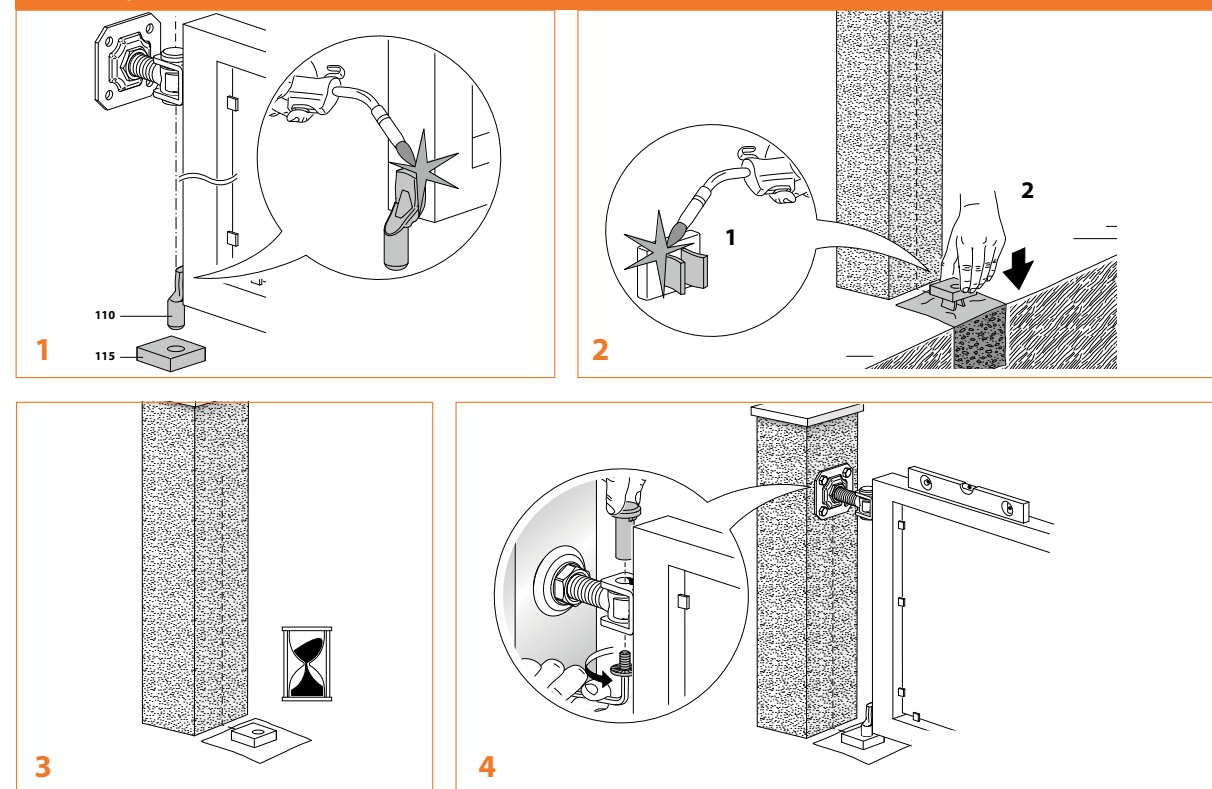



115PST

Piastra base a fissare per perno inferiore

Base plate to be screwed for bottom pin

Plaque de base à visser avec pivot inférieur

Bodenplatte zum Anschrauben für unteren Drehstift

Placa de base para fijar para perno inferior

Базовая прикрепляемая пластина для нижнего штифта

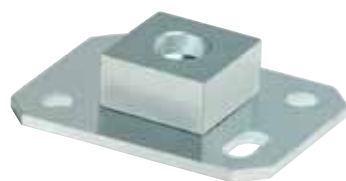

CODE	ART.	D	R	Portata con cardine superiore Capacity with top hinge	Box info	
					Pcs per pack	Kg
10806405 001	115PST-20,5	20,5	10	150 kg	5	2,8
10806410 001	115PST-24,5	24,5	10	240 kg	5	2,7
10806415 001	115PST-28	28	10	295 kg	5	2,6

Finishing: Zincato / Galvanized

Categoria commerciale: 1A

La portata è riferita ad una coppia di cardini nel caso di peso uniformemente distribuito in un'anta con L=H.
Weight bearing capacity refers to a pair of hinges mounted on a gate with weight uniformly distributed on a leaf with proportions L=H.

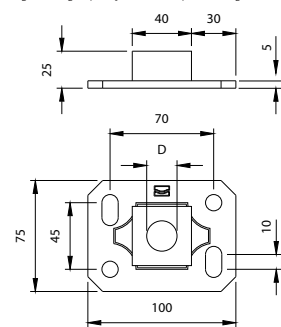

Peso uniformemente distribuito
Equally distributed weight



116i

Perno e piastra a saldare

Pivot and plate to be welded

Pivot et plaque à souder

Drehstift und Platte zum Schweißen

Perno y placa para soldar

Привариваемые штифт и пластина



CODE	ART.	A	C	D	E	G	H	P	S1	S2	Portata Capacity	Box info	
												Pcs per pack	Kg
10806205	116i-20	60	11,5	Ø20	29	25	91	35	15	11	150 kg	2	1,3
10806210	116i-24	70	14	Ø24	35	27	107	39	20	14	240 kg	2	2,2

Finishing: Inox / Stainless steel

Categoria commerciale: 2A

La portata è riferita ad una coppia di cardini nel caso di peso uniformemente distribuito in un'anta con L=H.
Weight bearing capacity refers to a pair of hinges mounted on a gate with weight uniformly distributed on a leaf with proportions L=H.

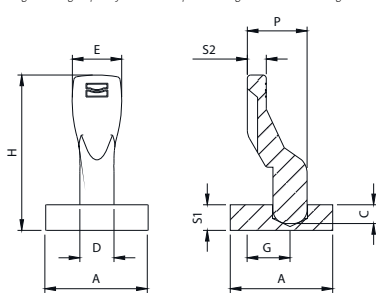

Peso uniformemente distribuito
Equally distributed weight

117

Piastra regolabile per perno inferiore

Adjustable plate for bottom pin

Plaque réglable pour pivot inférieur

Verstellbare Platte für unteren Drehstift

Placa regulable para perno inferior

Регулируемая пластина для нижнего штифта

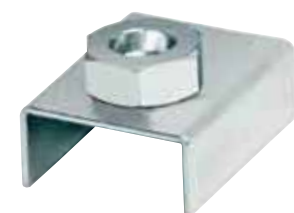

CODE	ART.	D	H	R	Portata con cardine superiore Capacity with top hinge	Box info	
						Pcs per pack	Kg
10807305 001	117-20,5	20,5	48	25-45	125 kg	12	4,8
10807310 001	117-24,5	24,5	48	25-45	200 kg	12	5,0
10807315 001	117-28	28	51	25-45	250 kg	12	5,7

Finishing: Zincato / Galvanized

Categoria commerciale: 1A

La portata è riferita ad una coppia di cardini nel caso di peso uniformemente distribuito in un'anta con L=H.
Weight bearing capacity refers to a pair of hinges mounted on a gate with weight uniformly distributed on a leaf with proportions L=H.

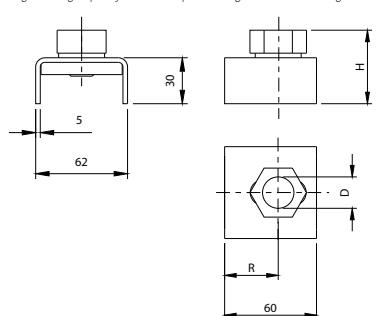

Peso uniformemente distribuito
Equally distributed weight



117PST

Piastra regolabile per perno inferiore a fissare

Adjustable plate for bottom pin to be screwed

Plaque réglable pour pivot inférieur à visser

Verstellbare Platte für unteren Drehstift zum Anschrauben

Placa regulable para perno inferior para fijar

Прикрепляемая регулируемая пластина для нижнего штифта



CODE	ART.	D	H	R	Portata Capacity	Box info	
						Pcs per pack	Kg
10807405 001	117PST-20,5	20,5	48	30-50	125 kg	2	1,5
10807410 001	117PST-24,5	24,5	48	30-50	200 kg	2	1,9
10807415 001	117PST-28	28	51	50-70	250 kg	2	1,7

Finishing: Zincato / Galvanized

Categoria commerciale: 1A

La portata è riferita ad una coppia di cardini nel caso di peso uniformemente distribuito in un'anta con L=H.
Weight bearing capacity refers to a pair of hinges mounted on a gate with weight uniformly distributed on a leaf with proportions L=H.

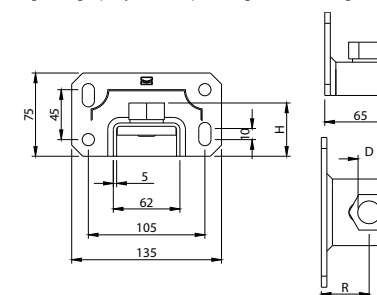

Peso uniformemente distribuito
Equally distributed weight



125

Cardine con cavallotto a cementare

Hinge to be cemented with u-bolt

Gond à sceller avec crampillon

Torband mit Mauerhülse und U-Bügel

Bisagra con pletina en U para cementar

Петля со скобой для посадки на цемент



CODE	ART.	A	B	C	E	F	G	H	M	P	R	S	Portata Capacity	Box info	
														Pcs per pack	Kg
10807005 001	125-M20	30	40	37	90	Ø27	25	47	M20	38	43-73	5	150 kg	20	10,2
10807010 001	125-M24	35	45	49	105	Ø30	27	59	M24	44	50-75	6	225 kg	10	7,8

Finishing: Zincato / Galvanized

Categoria commerciale: 1A

La portata è riferita ad una coppia di cardini nel caso di peso uniformemente distribuito in un'anta con L=H.
Weight bearing capacity refers to a pair of hinges mounted on a gate with weight uniformly distributed on a leaf with proportions L=H.

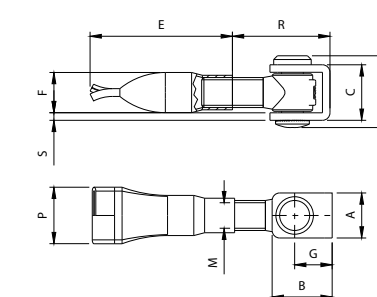

Peso uniformemente distribuito
Equally distributed weight



120

Cardine con cavallotto e bussola
Hinge with u-bolt and bush
Gond avec crampillon et douille
Torband mit U-Bügel und Buchse
Bisagra con pletina en U y casquillo
Петля со скобой и втулкой



CODE	ART.	A	B	C	E	F	G	H	L	M	R	S	Portata Capacity	Box info	
														Pcs per pack	Kg
10806500 001	120-M18	30	40	37	20	Ø25	25	47	90	M18	49-69	5	125 kg	20	8,6
10806505 001	120-M20	30	40	37	20	Ø25	25	47	90	M20	49-69	5	150 kg	20	8,6
10806509 001	120-M22	35	45	49	26	Ø29	27	59	100	M22	55-75	6	220 kg	10	6,9
10806510 001	120-M24	35	45	49	26	Ø29	27	59	100	M24	55-75	6	225 kg	10	7,4
10806505 020	120-M20 Hs700	30	40	37	20	Ø25	25	47	90	M20	49-69	5	150 kg	20	8,6
10806510 020	120-M24 Hs700	35	45	49	26	Ø29	27	59	100	M24	55-75	6	225 kg	10	7,4

Finishing: Zincato / Galvanized

Categoria commerciale: 1A

La portata è riferita ad una coppia di cardini nel caso di peso uniformemente distribuito in un'anta con L=H.
Weight bearing capacity refers to a pair of hinges mounted on a gate with weight uniformly distributed on a leaf with proportions L=H.

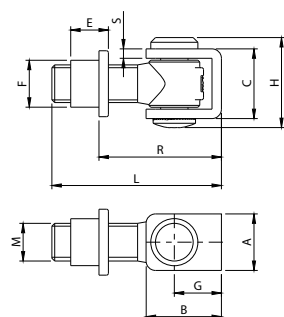

Peso uniformemente distribuito
Equally distributed weight

Mounting instructions art. 120

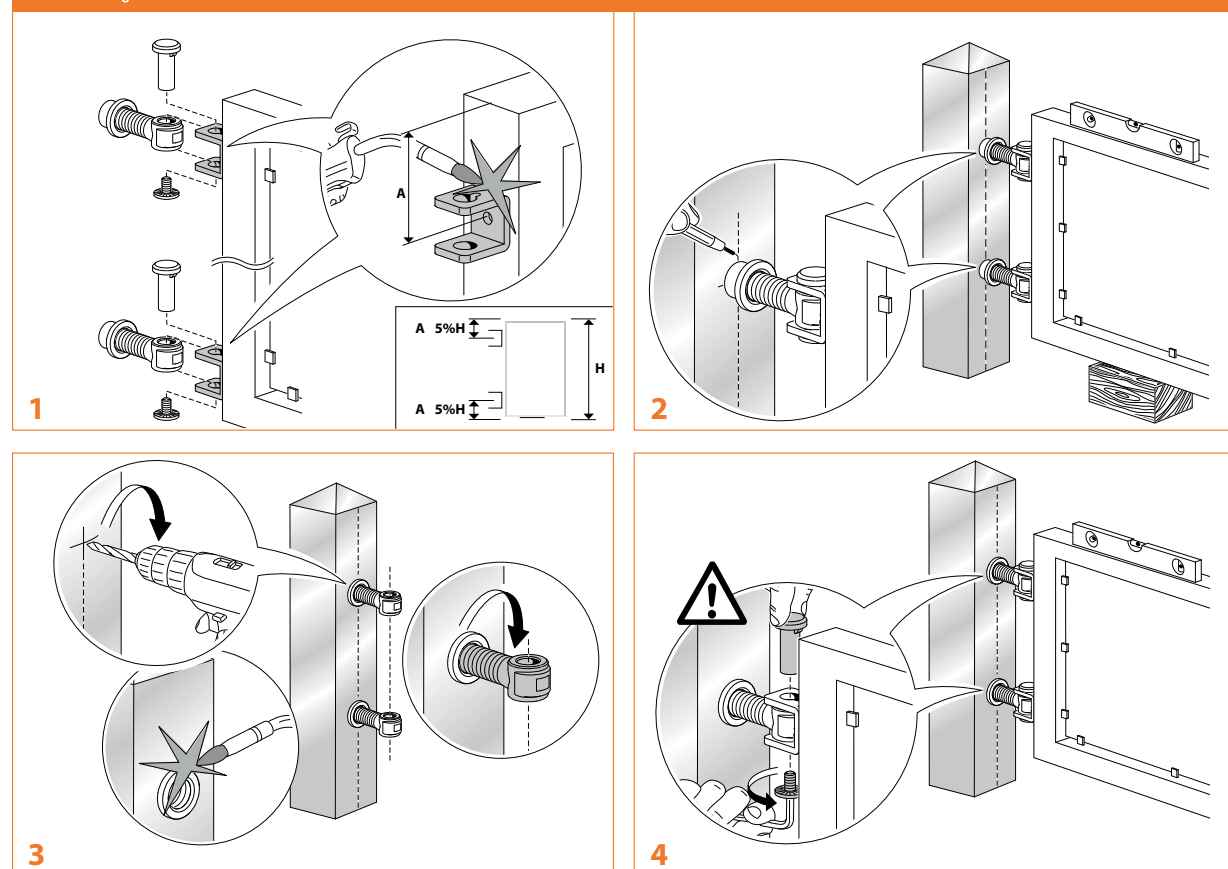

135

Cardine con ali e bussola
Hinge with wings and bush
Gond avec ailes et douille
Torband mit Lasche und Buchse
Bisagra con palas y casquillo
Петля с полками и втулкой



CODE	ART.	A	B	C	E	F	G	H	L	M	R	S	Portata Capacity	Box info	
														Pcs per pack	Kg
10808005 001	135-M18	33	40	39	20	Ø25	25	49	85	M18	50-70	6	125 kg	20	7,9
10808009 001	135-M20	33	40	39	20	Ø25	25	49	85	M20	50-70	6	150 kg	20	8,9
10808010 001	135-M22	40	47	53	20	Ø25	27	64	95	M22	55-80	8	220 kg	10	7,0
10808014 001	135-M24	40	47	53	20	Ø27	27	64	95	M24	60-80	8	225 kg	10	8,0
10808015 001	135-M27	50	52	60	26	Ø35,5	30	71	117	M27	62-98	10	320 kg	10	11

Finishing: Zincato / Galvanized

Categoria commerciale: 1A

La portata è riferita ad una coppia di cardini nel caso di peso uniformemente distribuito in un'anta con L=H.
Weight bearing capacity refers to a pair of hinges mounted on a gate with weight uniformly distributed on a leaf with proportions L=H.

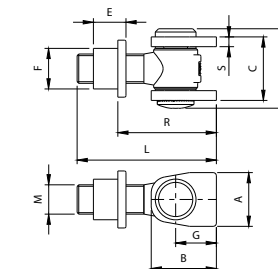

Peso uniformemente distribuito
Equally distributed weight

Mounting instructions art. 135

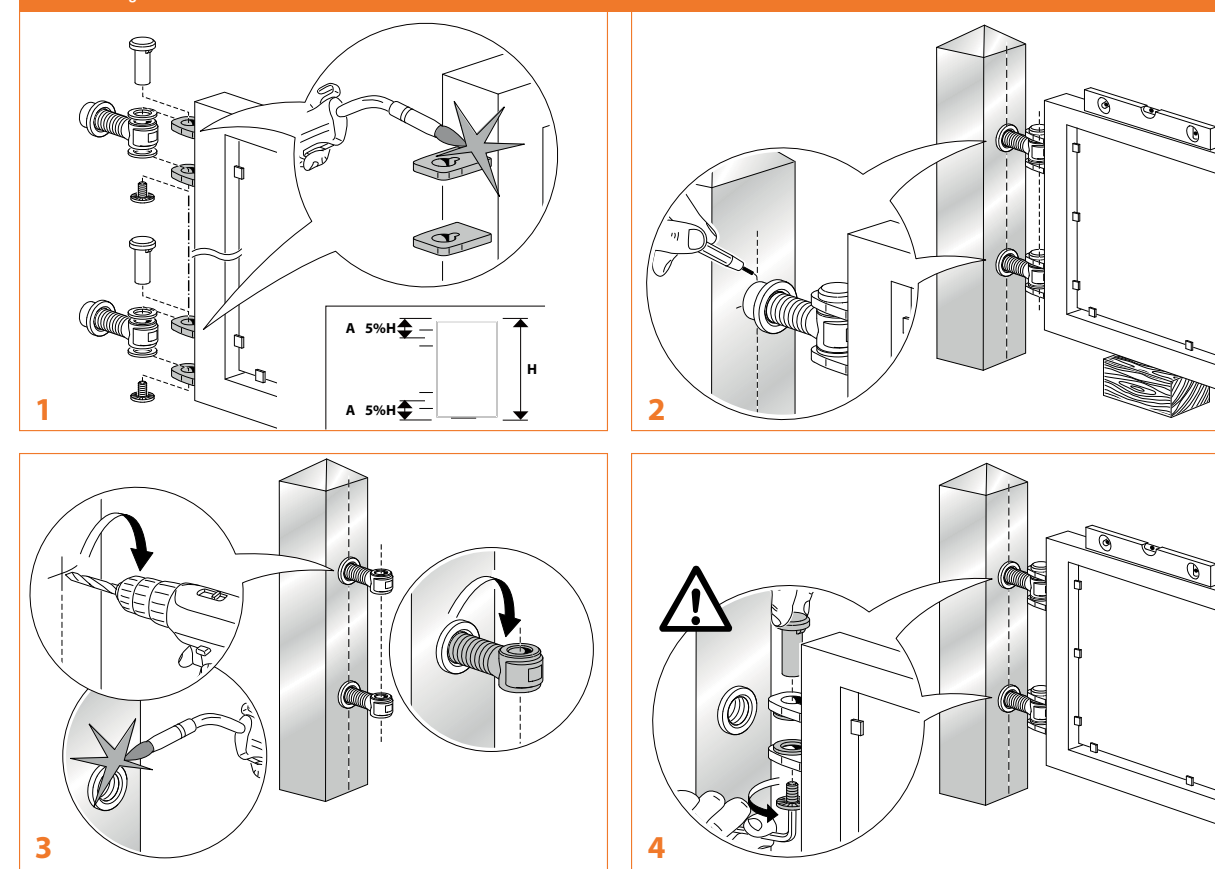



130

Cardine con cavallotto a barra lunga filettata

Hinge with long bar and u-bolt
Gond avec barre long filetée et crampillon
Torband mit langem Gewinde und U-Bügel
Bisagra con pletina en U con varilla roscada larga
Петля со скобой с длинным резьбовым стержнем



CODE	ART.	A	B	C	E	G	H	L	M	S	Portata Capacity	Box info		
												Pcs per pack	Kg	
10807505 001	130-M20	30	40	37	9	25	47	182	M20	5	30	150 kg	20	12,1
10807510 001	130-M24	35	45	49	10	27	59	187	M24	6	36	225 kg	10	10,1

Finishing: Zincato / Galvanized

Categoria commerciale: 1A

La portata è riferita ad una coppia di cardini nel caso di peso uniformemente distribuito in un'anta con L=H.
Weight bearing capacity refers to a pair of hinges mounted on a gate with weight uniformly distributed on a leaf with proportions L=H.

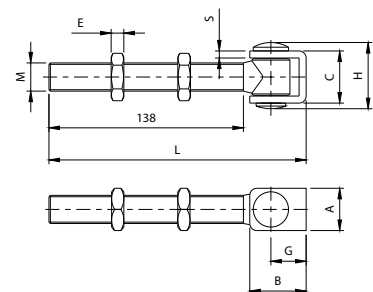

Peso uniformemente distribuito
Equally distributed weight

140

Cardine con ali a cementare

Hinge with wings to be cemented
Gond à sceller avec ailes
Torband mit Mauerhülse und Laschen
Bisagra con palas para cementar
Петля с полками для посадки на цемент



CODE	ART.	A	B	C	E	F	G	H	M	P	R	S	Portata Capacity	Box info	
														Pcs per pack	Kg
10808505 001	140-M18	33	40	39	95	Ø25	25	49	M18	38	45-65	6	125 kg	20	7,1
10808510 001	140-M22	40	47	53	100	Ø27	27	64	M22	38	50-80	8	220 kg	10	5,5
10808515 001	140-M27	50	52	60	110	Ø30	30	71	M27	44	55-97	10	320 kg	10	10,5

Finishing: Zincato / Galvanized

Categoria commerciale: 1A

La portata è riferita ad una coppia di cardini nel caso di peso uniformemente distribuito in un'anta con L=H.
Weight bearing capacity refers to a pair of hinges mounted on a gate with weight uniformly distributed on a leaf with proportions L=H.

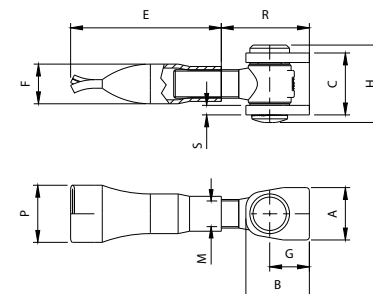

Peso uniformemente distribuito
Equally distributed weight

150

Cardine con ali a barra lunga filettata

Hinge with long bar and wings
Gond avec barre long filetée et ailes
Torband mit langem Gewinde und Laschen
Bisagra con palas con varilla roscada larga
Петля с полками с длинным резьбовым стержнем



CODE	ART.	A	B	C	E	G	H	L	M	S	Portata Capacity	Box info		
												Pcs per pack	Kg	
10809005 001	150-M18	33	40	39	9	25	49	185	M18	6	27	125 kg	20	9,5
10809010 001	150-M22	40	47	53	10	27	64	187	M22	8	32	220 kg	10	7,6

Finishing: Zincato / Galvanized

Categoria commerciale: 1C

La portata è riferita ad una coppia di cardini nel caso di peso uniformemente distribuito in un'anta con L=H.
Weight bearing capacity refers to a pair of hinges mounted on a gate with weight uniformly distributed on a leaf with proportions L=H.

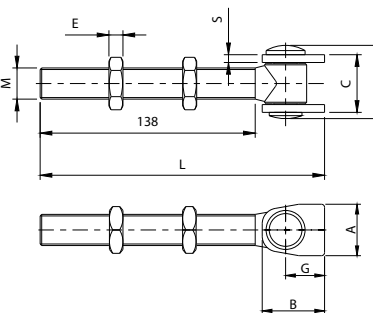

Peso uniformemente distribuito
Equally distributed weight

154

Piastra "Rustica" con dado regolabile

Plate "Rustica" with adjustable nut
Platine "Rustica" avec écrou réglable
Platte "Rustica" mit verstellbarer Mutter
Placa "Rustica" (Rústica) con tuerca regulable
Плита "Rustica" с регулируемой гайкой



CODE	ART.	E	M	S	Box info	
					Pcs per pack	Kg
10824705 001	154-M18	18	M18	32	10	4,8
10824710 001	154-M20	18	M20	32	10	4,8
10824715 001	154-M22	18	M22	36	10	4,8
10824720 001	154-M24	18	M24	36	10	4,8
10824725 001	154-M27	25	M27	41	10	5,5

Finishing: Zincato / Galvanized

Categoria commerciale: 1A

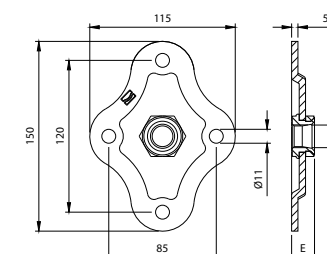

157CV

Piastra " Rettangolare " con dado regolabile

Plate " Rettangolare " with adjustable nut
Platine " Rettangolare " avec écrou réglable
Platte " Rettangolare " mit verstellbarer Mutter
Placa " Rettangolare " (Rectangular) con tuerca regulable
Плита " Rettangolare " с регулируемой гайкой



CODE	ART.	C	M	R	Portata Capacity	Box info	
						Pcs per pack	Kg
10824605 001	157CV-M18	37	18	62-85	125 kg	20	13,0
10824610 001	157CV-M20	37	20	62-85	150 kg	20	13,2
10824615 001	157CV-M22	49	22	70-95	220 kg	10	9,2
10824620 001	157CV-M24	49	24	70-100	225 kg	10	9,6

Finishing: Zincato / Galvanized

Categoria commerciale: 1A

La portata è riferita ad una coppia di cardini nel caso di peso uniformemente distribuito in un'anta con L=H.
Weight bearing capacity refers to a pair of hinges mounted on a gate with weight uniformly distributed on a leaf with proportions L=H.

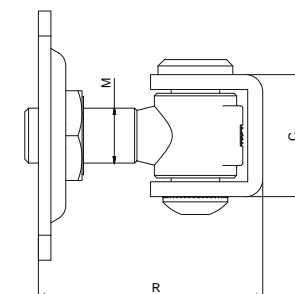

Peso uniformemente distribuito
Equally distributed weight

157AL

Cardine con ali e piastra "rettangolare" con dado regolabile

Hinge with wings and Plate " Rettangolare " with adjustable nut
Gond avec ailes et platine " Rettangolare " avec écrou réglable
Torband mit Laschen und platte " Rettangolare " mit verstellbarer Mutter
Bisagra con palas y placa " Rettangolare " (Rectangular) con tuerca regulable
Петля с полками и пластиной " Rettangolare " с регулируемой гайкой



CODE	ART.	C	M	R	Portata Capacity	Box info	
						Pcs per pack	Kg
10824905 001	157-AL-M18	39	18	62-85	125 kg	20	12,5
10824910 001	157-AL-M20	39	20	62-85	150 kg	20	13,3
10824915 001	157-AL-M22	53	22	70-95	220 kg	10	9,4
10824920 001	157-AL-M24	53	24	70-100	225 kg	10	10,3

Finishing: Zincato / Galvanized

Categoria commerciale: 1A

La portata è riferita ad una coppia di cardini nel caso di peso uniformemente distribuito in un'anta con L=H.
Weight bearing capacity refers to a pair of hinges mounted on a gate with weight uniformly distributed on a leaf with proportions L=H.

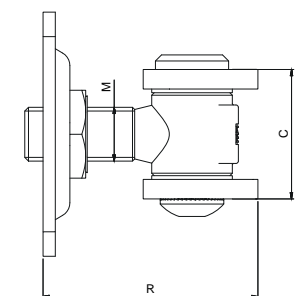

Peso uniformemente distribuito
Equally distributed weight



154R-CV

Piastra "Rustica" doppia regolazione su 2 assi x - y
Plate "Rustica" double adjustment on 2 axis x-y
Platine "Rustica" avec double réglage sur les axes x-y
Platte "Rustica" 2 Achsen x-y Doppelverstellung
Placa "Rustica"(Rústica) doble regulación en 2 ejes x-y
Пластина "Rustica" с двойным регулированием по 2 осям x-y



CODE	ART.	C	M	Rx	Ry	Portata Capacity	Box info	
							Pcs per pack	Kg
10824405 001	154R-CV-M18	37	18	82-86	10	125 kg	20	18,0
10824410 001	154R-CV-M20	37	20	87-90	10	150 kg	20	18,3
10824415 001	154R-CV-M22	49	22	94-96	10	220 kg	10	13,2
10824420 001	154R-CV-M24	49	24	95-100	10	225 kg	10	13,5

Finishing: Zincato / Galvanized

Categoria commerciale: 1A

La portata è riferita ad una coppia di cardini nel caso di peso uniformemente distribuito in un'anta con L=H.
Weight bearing capacity refers to a pair of hinges mounted on a gate with weight uniformly distributed on a leaf with proportions L=H.

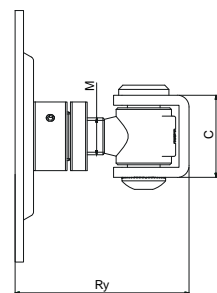
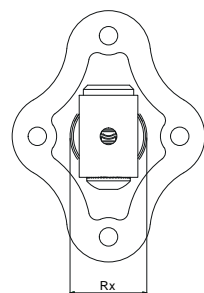

PATENTED

155

Cardine con cavallotto e dado regolabile
Hinge with u-bolt and adjustable nut
Gond avec crampillon et écrou réglable
Torband mit U-Bügel und verstellbare Mutter
Bisagra con pletina en U y tuerca regulable
Пластина со скобой и регулируемой гайкой



CODE	ART.	A	B	C	E	F	G	H	L	M	R	S	Portata Capacity	Box info		
														Pcs per pack	Kg	
10809505 001	155-M20	30	40	37	19	Ø44	25	47	90	M20	70-90	5	30	150 kg	20	9,2
10809510 001	155-M24	35	45	49	26	Ø62	27	59	100	M24	75-100	6	36	225 kg	10	8,2

Finishing: Zincato / Galvanized

Categoria commerciale: 1A

La portata è riferita ad una coppia di cardini nel caso di peso uniformemente distribuito in un'anta con L=H.
Weight bearing capacity refers to a pair of hinges mounted on a gate with weight uniformly distributed on a leaf with proportions L=H.

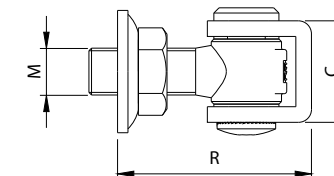

Mounting instructions art. 154R-CV

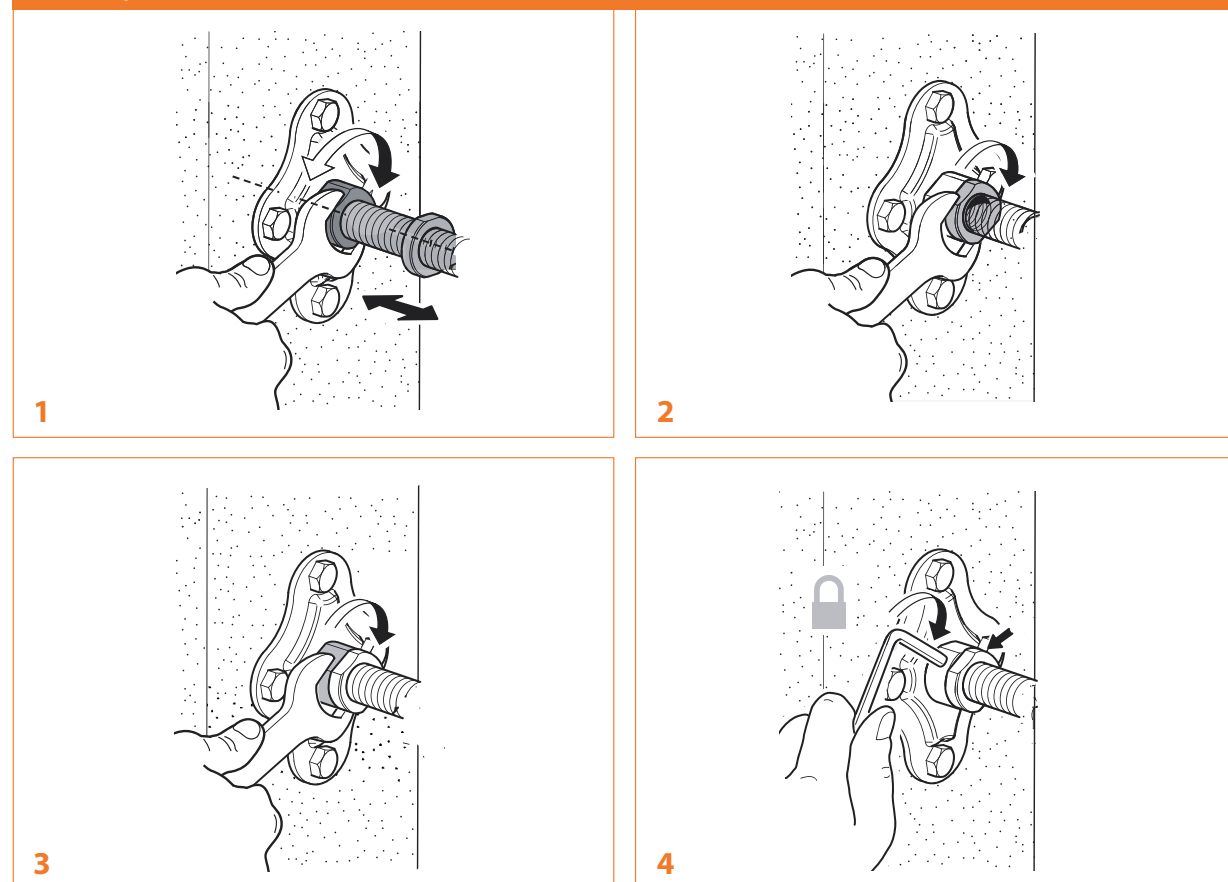

Mounting instructions art. 155

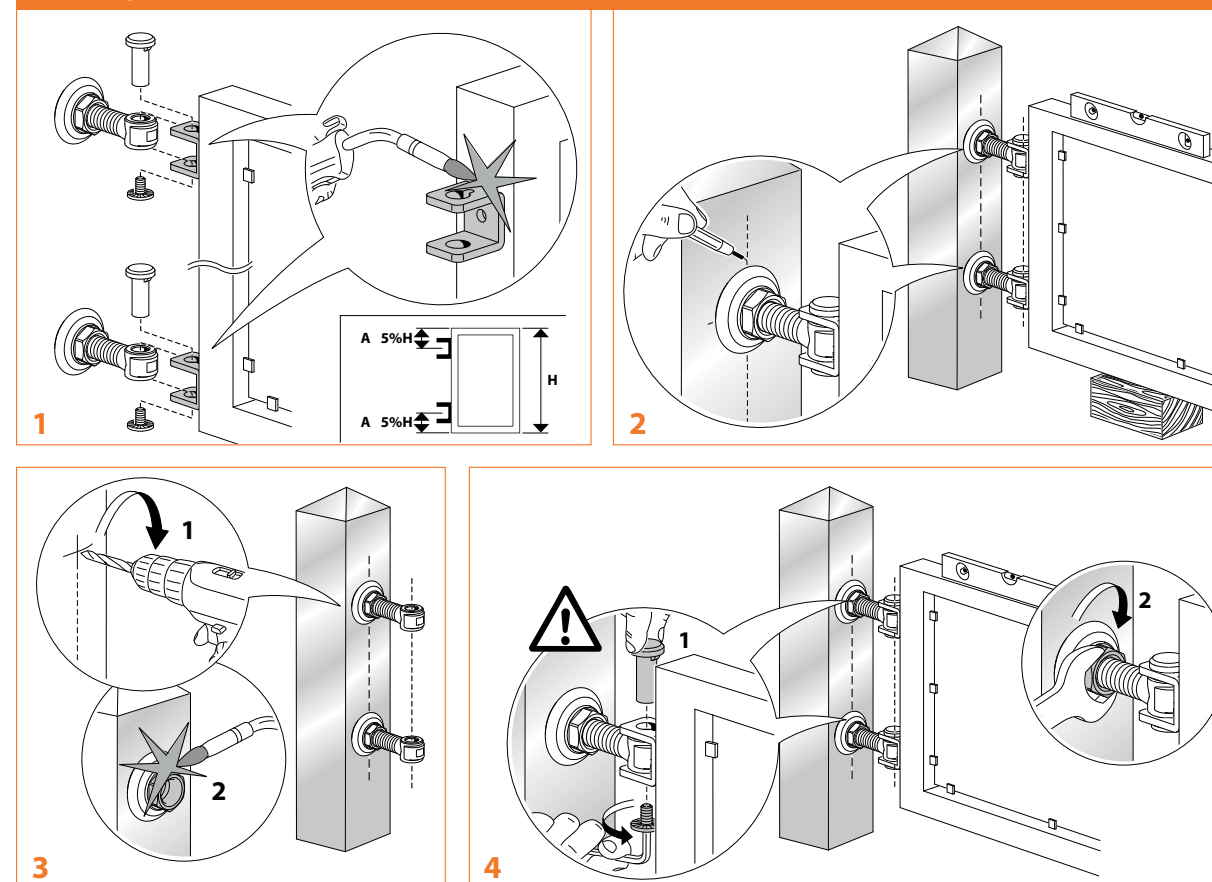



159

Piastra "Quadrata" con dado regolabile
Plate "Quadrata" with adjustable nut
Platine "Quadrata" avec écrou réglable
Platte "Quadrata" mit verstellbarer Mutter
Placa "Quadrata" (Cuadrada) con tuerca regulable
Пластина "Quadrata" с регулируемой гайкой



CODE	ART.	A	E	F	G	M		Box info	
								Pcs per pack	Kg
10823505 001	159-M18	100	18	Ø11	65	M18	32	10	4,5
10823510 001	159-M20	100	18	Ø11	65	M20	32	10	4,5
10823515 001	159-M22	100	18	Ø11	65	M22	36	10	4,5
10823520 001	159-M24	100	18	Ø11	65	M24	36	10	4,3
10823525 001	159-M27	130	25	Ø13	90	M27	41	10	8,0

Finishing: Zincato / Galvanized

Categoria commerciale: 1A

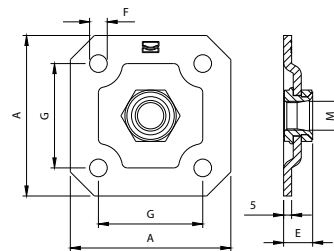

159R-CV

Piastra "Quadrata" doppia regolazione
su 2 assi x - y
Plate "Quadrata" double adjustment on 2 axis x-y
Platine "Quadrata" double réglage sur les axes x-y
Platte "Quadrata" 2 Achsen x-y Doppelverstellung
Placa "Quadrata" (Cuadrada) doble regulación en 2 ejes x-y
Пластина "Quadrata" с двойным регулированием по 2 осям x-y



CODE	ART.	C	M	Rx	Ry	Portata Capacity	Box info	
							Pcs per pack	Kg
10823405 001	159R-CV-M18	37	18	82-86	10	125 kg	20	17,1
10823410 001	159R-CV-M20	37	20	87-90	10	150 kg	20	17,3
10823415 001	159R-CV-M22	49	22	94-96	10	220 kg	10	12,7
10823420 001	159R-CV-M24	49	24	95-100	10	225 kg	10	13,0

Finishing: Zincato / Galvanized

Categoria commerciale: 1A

La portata è riferita ad una coppia di cardini nel caso di peso uniformemente distribuito in un'anta con L=H.
Weight bearing capacity refers to a pair of hinges mounted on a gate with weight uniformly distributed on a leaf with proportions L=H.

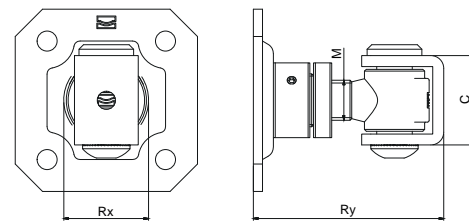

160XL

Cardine maxi con ali e dado regolabile
Hinge maxi with wings and adjustable nut
Gond maxi avec ailes et écrou réglable
Torband maxi mit Laschen und verstellbare Mutter
Bisagra maxi con palas y tuerca regulable
Увеличенная петля с полками и регулируемой гайкой



CODE	ART.	Box info	
		Pcs per pack	Kg
10801912 001	160XL	2	7,0

Finishing: Zincato / Galvanized

Categoria commerciale: 1A

La portata è riferita ad una coppia di cardini nel caso di peso uniformemente distribuito in un'anta con L=H.
Weight bearing capacity refers to a pair of hinges mounted on a gate with weight uniformly distributed on a leaf with proportions L=H.

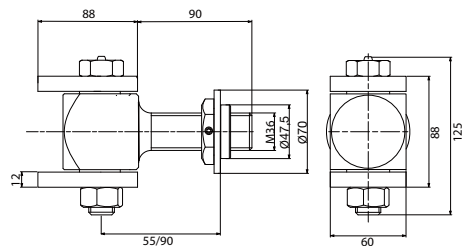

160

Cardine con ali e dado regolabile
Hinge with wings and adjustable nut
Gond avec ailes et écrou réglable
Torband mit Laschen und verstellbare Mutter
Bisagra con palas y tuerca regulable
Петля с полками и регулируемой гайкой



CODE	ART.	A	B	C	E	F	G	H	L	M	R	S		Portata Capacity	Box info	
															Pcs per pack	Kg
10810005 001	160-M18	33	40	39	18	Ø40	25	49	85	M18	70-85	6	27	125 kg	20	8,1
10810010 001	160-M22	40	47	53	10	Ø49	27	64	95	M22	70-95	8	30	220 kg	10	7,4
10810015 001	160-M27	50	52	60	25	Ø62	30	71	117	M27	80-117	10	40	320 kg	10	10,5

Finishing: Zincato / Galvanized

Categoria commerciale: 1A

La portata è riferita ad una coppia di cardini nel caso di peso uniformemente distribuito in un'anta con L=H.
Weight bearing capacity refers to a pair of hinges mounted on a gate with weight uniformly distributed on a leaf with proportions L=H.

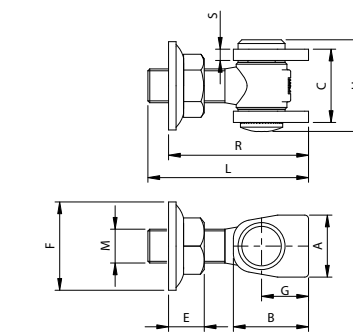

Mounting instructions art. 160



161

Cardine con cavallotto e piastra con dado regolabile

Hinge with u bolt and plate with adjustable nut
Gond avec crampillon et platine avec écrou réglable
Torband mit U-Bügel und Platte mit verstellbarer Mutter
Bisagra con pletina en U y placa con tuerca regulable
Петля со скобой и пластиной с регулируемой гайкой



CODE	ART.	A	B	C	G	H	L	M	R	S	Portata Capacity	Box info		
												Pcs per pack	Kg	
10810300 001	161-M18	30	40	37	25	47	90	M18	62-85	5	32	125 kg	20	14,5
10810305 001	161-M20	30	40	37	25	47	85	M20	60-85	5	32	150 kg	20	15,8
10810309 001	161-M22	35	45	49	27	59	100	M22	70-95	6	36	220 kg	10	9,0
10810310 001	161-M24	35	45	49	27	59	100	M24	70-100	6	36	225 kg	10	10,7

Finishing: Zincato / Galvanized

Categoria commerciale: 1A

La portata è riferita ad una coppia di cardini nel caso di peso uniformemente distribuito in un'anta con L=H.
Weight bearing capacity refers to a pair of hinges mounted on a gate with weight uniformly distributed on a leaf with proportions L=H.

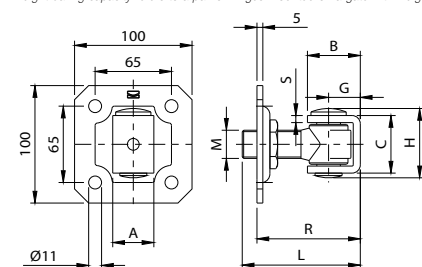

162

Cardine con cavallotto e piastra con bussola

Hinge with u bolt and plate with bush
Gond avec crampillon et platine avec douille
Torband mit U-Bügel und Platte mit Buchse
Bisagra con pletina en U y placa con casquillo
Петля со скобой и пластиной со втулкой



CODE	ART.	A	B	C	G	H	L	M	R	S	Portata Capacity	Box info	
												Pcs per pack	Kg
10810505 001	162-M20	30	40	37	25	47	85	M20	60-85	5	150 kg	20	15,6
10810510 001	162-M24	35	45	49	27	59	100	M24	70-100	6	225 kg	10	10,9

Finishing: Zincato / Galvanized

Categoria commerciale: 1A

La portata è riferita ad una coppia di cardini nel caso di peso uniformemente distribuito in un'anta con L=H.
Weight bearing capacity refers to a pair of hinges mounted on a gate with weight uniformly distributed on a leaf with proportions L=H.

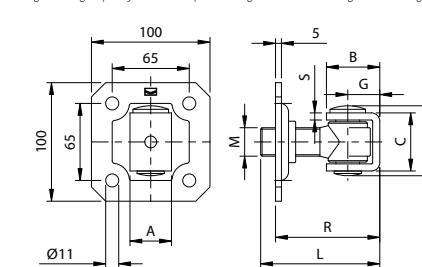

163

Cardine con ali e piastra con dado regolabile

Hinge with wings and plate with adjustable nut
Gond avec ailes et platine avec écrou réglable
Torband mit Laschen und Platte mit verstellbarer Mutter
Bisagra con palas y placa con tuerca regulable
Петля с полками и пластиной с регулируемой гайкой



CODE	ART.	A	B	C	E	F	G	H	I	L	M	R	S	Portata Capacity	Box info		
															Pcs per pack	Kg	
10810805 001	163-M18	33	40	39	100	Ø11	25	49	65	85	M18	62-85	6	32	125 kg	20	14,2
10810809 001	163-M20	33	40	39	100	Ø11	25	49	65	85	M20	62-85	6	32	150 kg	20	15,0
10810810 001	163-M22	40	47	53	100	Ø11	27	64	65	95	M22	70-95	8	36	220 kg	10	10,7
10810814 001	163-M24	40	47	53	100	Ø11	27	64	65	95	M24	70-95	8	36	225 kg	10	10,2
10810815 001	163-M27	50	52	60	130	Ø13	30	71	90	117	M27	80-117	10	41	320 kg	10	17,7

Finishing: Zincato / Galvanized

Categoria commerciale: 1A

La portata è riferita ad una coppia di cardini nel caso di peso uniformemente distribuito in un'anta con L=H.
Weight bearing capacity refers to a pair of hinges mounted on a gate with weight uniformly distributed on a leaf with proportions L=H.

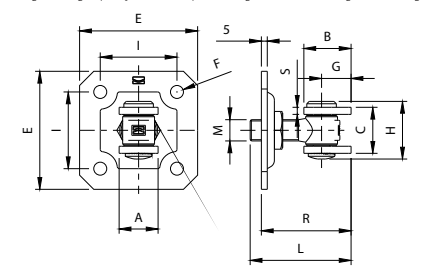

164

Cardine con ali e piastra con bussola

Hinge with wings and plate with bush
Gond avec ailes et platine avec douille
Torband mit Laschen und Platte mit Buchse
Bisagra con palas y placa con casquillo
Петля с полками и пластиной со втулкой



CODE	ART.	A	B	C	E	F	G	H	I	L	M	R	S	Portata Capacity	Box info	
															Pcs per pack	Kg
10811005 001	164-M18	33	40	39	100	Ø11	25	49	65	85	M18	62-85	6	125 kg	20	13,5
10811010 001	164-M22	40	47	53	100	Ø11	27	64	65	95	M22	70-95	8	220 kg	10	8,50
10811015 001	164-M27	50	52	60	130	Ø13	30	71	90	117	M27	80-117	10	320 kg	10	16,3

Finishing: Zincato / Galvanized

Categoria commerciale: 1A

La portata è riferita ad una coppia di cardini nel caso di peso uniformemente distribuito in un'anta con L=H.
Weight bearing capacity refers to a pair of hinges mounted on a gate with weight uniformly distributed on a leaf with proportions L=H.

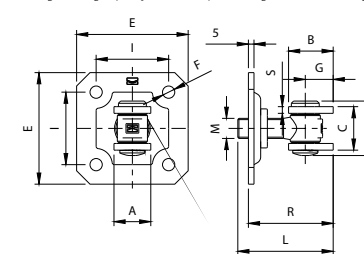

176

Cardine doppio corpo con cavallotto per apertura a 180°

Hinge with double body and u bolt for 180° opening
Gond avec double corps et crampillon pour ouverture à 180°
Torband mit Doppelkörper und U-Bügel für 180° Öffnung
Bisagra doble cuerpo con pletina en U para apertura a 180°
Петля с двойным корпусом со скобой с открытием на 180°



CODE	ART.	R	Portata coppia Capacity pair	Box info	
				Pcs per pack	Kg
10820505 001	176	55-115	150 kg	10	20,0

Finishing: Zincato / Galvanized

Categoria commerciale: 1A

La portata è riferita ad una coppia di cardini nel caso di peso uniformemente distribuito in un'anta con L=H.
Weight bearing capacity refers to a pair of hinges mounted on a gate with weight uniformly distributed on a leaf with proportions L=H.

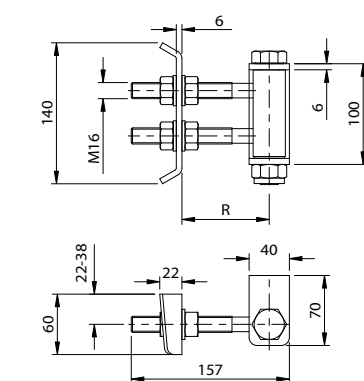



172

Cardine cilindrico con bussola
Cylindrical hinge with bush
Gond cylindrique avec douille
Zylindrischer Torband mit Buchse
Bisagra cilíndrica con casquillo
Цилиндрическая петля со втулкой



CODE	ART.	B	C	D	E	F	H	L	R	M	Portata Capacity	Box info	
												Pcs per pack	Kg
10821005 001	172-M18	25	25	Ø34,5	20	Ø25	89	78	43-62	M18	125 kg	20	8,70
10821010 001	172-M20	25	25	Ø34,5	20	Ø25	89	78	43-62	M20	155 kg	20	11,20
10821015 001	172-M24	34	30	Ø39,5	25	Ø29	105	94	46-72	M24	240 kg	10	10,00

Finishing: Zincato / Galvanized

Categoria commerciale: 1A

La portata è riferita ad una coppia di cardini nel caso di peso uniformemente distribuito in un'anta con L=H.
Weight bearing capacity refers to a pair of hinges mounted on a gate with weight uniformly distributed on a leaf with proportions L=H.

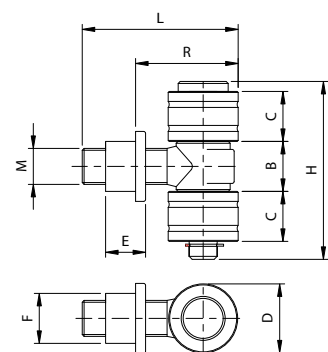

174

Cardine con cavalletto per apertura a 180°
Hinge with U bolt for 180° opening
Gond avec crampillon pour ouverture à 180°
Torband mit U-Bügel für 180° Öffnung
Bisagra con pletina en U para apertura a 180°
Петля со скобой с открытием на 180°



CODE	ART.	R	Portata Capacity	Box info	
				Pcs per pack	Kg
10820005 001	174-M16	50-110	75 kg	10	9,80

Finishing: Zincato / Galvanized

Categoria commerciale: 1A

La portata è riferita ad una coppia di cardini nel caso di peso uniformemente distribuito in un'anta con L=H.
Weight bearing capacity refers to a pair of hinges mounted on a gate with weight uniformly distributed on a leaf with proportions L=H.

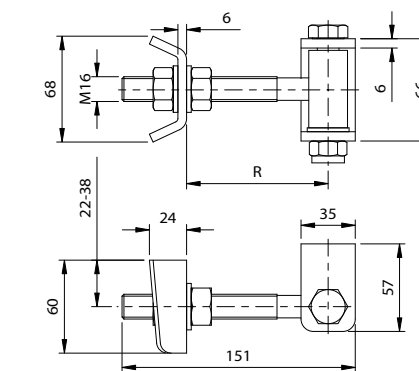

Mounting instructions art. 172

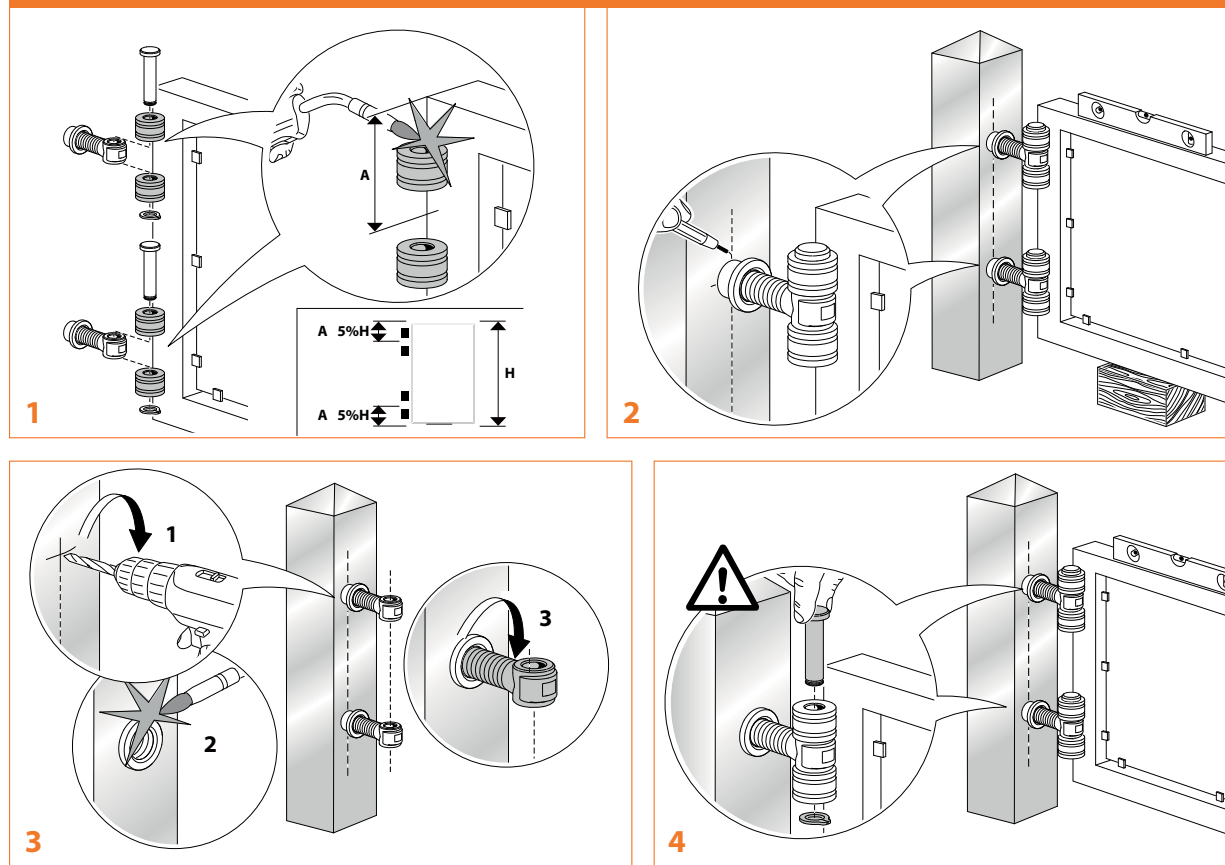

Mounting instructions art. 174

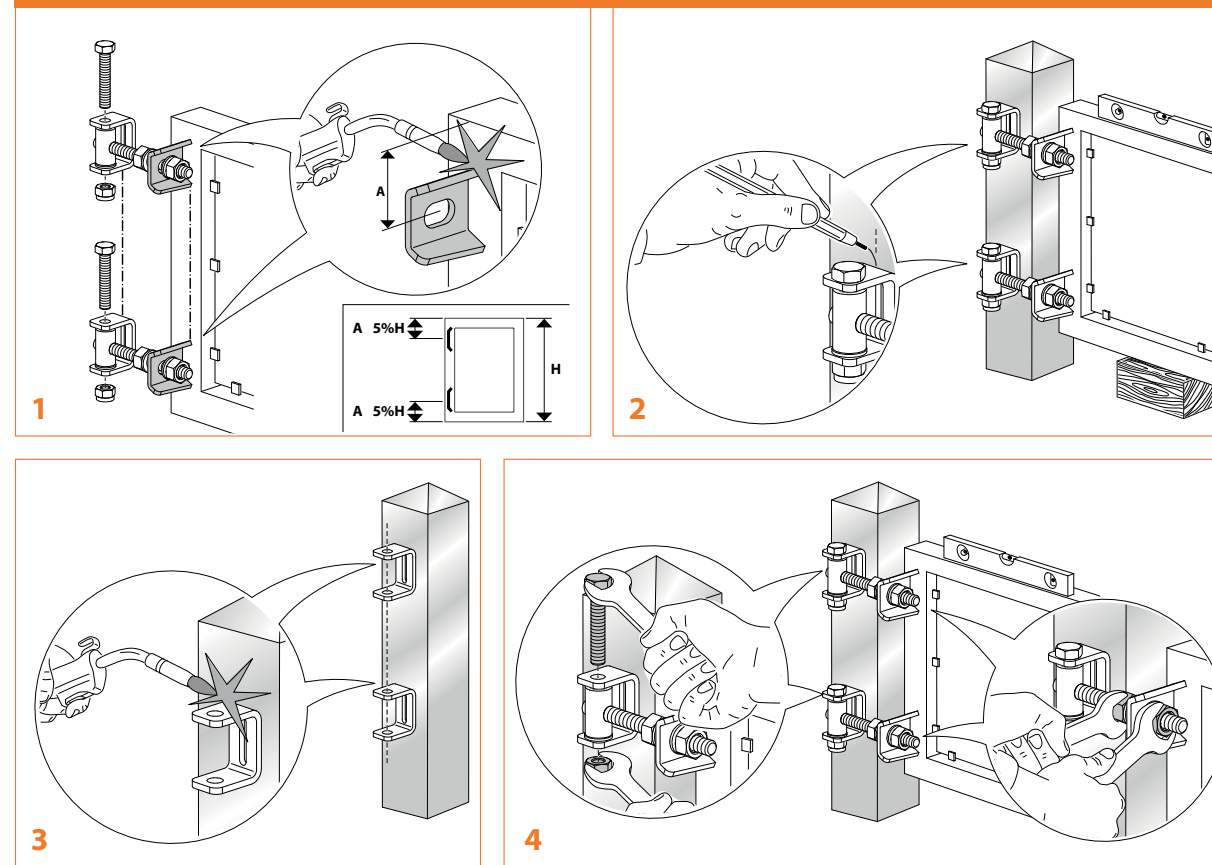



175

Cardine per apertura a 180°
Hinge for 180° opening
Gond pour ouverture à 180°
Torband für 180° Öffnung
Bisagra para apertura a 180°
Петля с открытием на 180°



CODE	ART.	L	H	R	Portata Capacity	Box info	
						Pcs per pack	Kg
19926003	175P	43	63	18	70 kg	8	7,9
19926004	175G	75	95	18	135 kg	6	8,6

Finishing: Non zincato / Not galvanized

Categoria commerciale: 1A

La portata è riferita ad una coppia di cardini nel caso di peso uniformemente distribuito in un'anta con L=H.
Weight bearing capacity refers to a pair of hinges mounted on a gate with weight uniformly distributed on a leaf with proportions L=H.

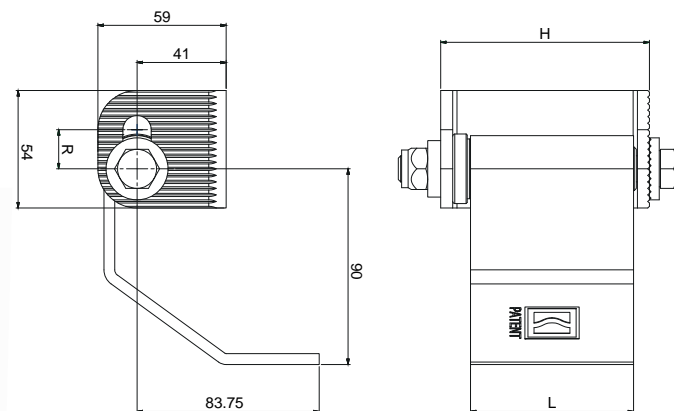

PATENTED

178

Cardine con ali per apertura a 180°
Hinge with wings for 180° opening
Gond avec ailes pour ouverture à 180°
Torband mit Laschen für 180° Öffnung
Bisagra con palas para apertura a 180°
Петля с полками с открытием на 180°



CODE	ART.	A	B	E	G	H	M	R1	R2	S1	S2	Portata Capacity	Box info		
													Pcs per pack	Kg	
10819505 001	178-M12	45	42	45	25	46	M12	35-80	45-60	6	6	22	50 kg	10	5,00
10819510 001	178-M16	45	42	60	25	46	M16	40-100	50-70	6	8	27	75 kg	10	8,60
10819515 001	178-M20	55	58	60	35	60	M20	45-100	90-110	8	8	32	125 kg	10	14,10
10819520 001	178-M24	55	58	70	35	60	M24	55-110	85-105	8	12	41	200 kg	10	22,20

Finishing: Zincato / Galvanized

Categoria commerciale: 1A

La portata è riferita ad una coppia di cardini nel caso di peso uniformemente distribuito in un'anta con L=H.
Weight bearing capacity refers to a pair of hinges mounted on a gate with weight uniformly distributed on a leaf with proportions L=H.

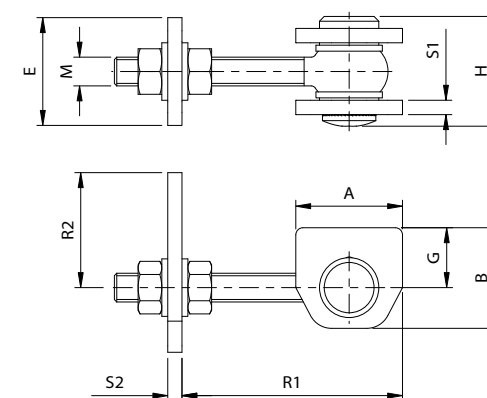

Mounting instructions art. 175

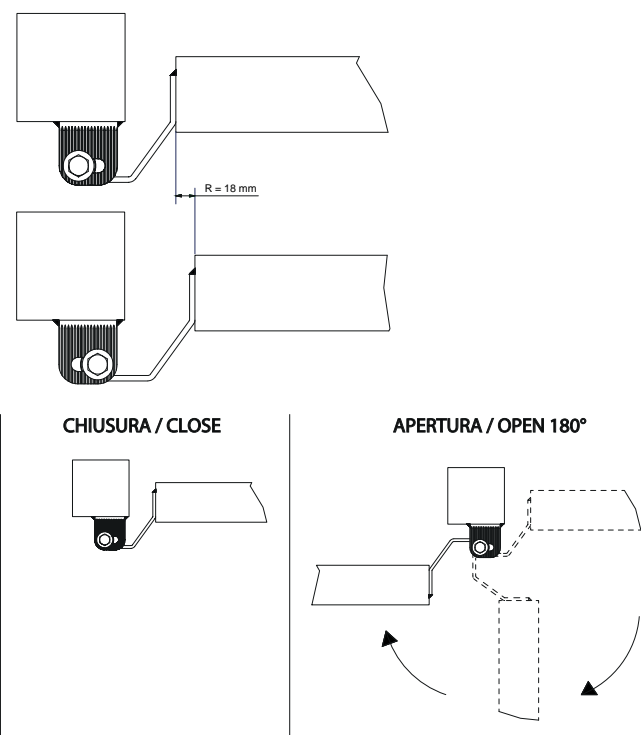

Mounting instructions art. 178

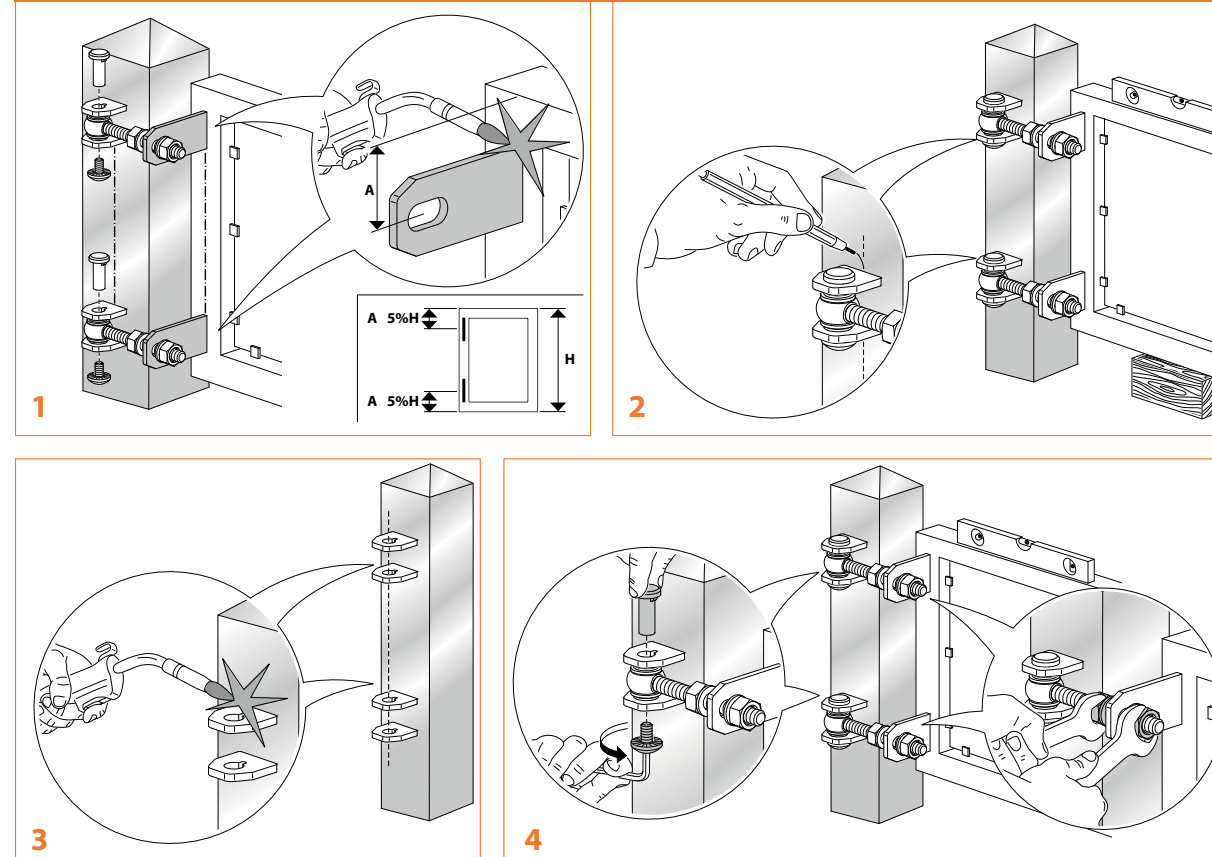



180

Cardine a fascetta con ingrassatore e bussola

Clamp-hinge with greaser and bush
Gond à collier avec graisseur et douille
Halseisenband mit Schmierbüchse und Buchse
Bisagra de abrazadera con engrasador y casquillo
Петля с полосой с масляной и втулкой



CODE	ART.	A	B	C	D	E	F	G	L	M	R	Portata Capacity	Box info	
													Pcs per pack	Kg
10814005 001	180-M18	42	56	30	Ø30	20	Ø25	21	106	M18	45-70	100 Kg	20	9,60
10814010 001	180-M22	47	60	35	Ø35	20	Ø27	23	122	M22	45-75	160 Kg	10	6,80
10814015 001	180-M27	52	67	40	Ø40	26	Ø33	28	141	M27	55-95	260 Kg	10	10,60

Finishing: Zincato / Galvanized

Categoria commerciale: 1A

La portata è riferita ad una coppia di cardini nel caso di peso uniformemente distribuito in un'anta con L=H.
Weight bearing capacity refers to a pair of hinges mounted on a gate with weight uniformly distributed on a leaf with proportions L=H.

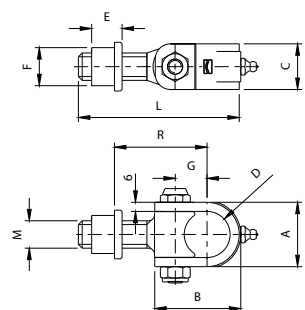

184

Cardine a fascetta a cementare con ingrassatore

Clamp-hinge with greaser to be cemented
Gond à collier avec graisseur à sceller
Halseisenbandkörper mit Schmierbüchse zum Ausbetonieren
Bisagra de abrazadera para cementar con engrasador
Петля с цементируемой полосой с масляной



CODE	ART.	A	B	C	D	E	F	G	L	M	P	R	Portata Capacity	Box info	
														Pcs per pack	Kg
10815005 001	184-M18	42	56	30	Ø30	95	Ø25	21	106	M18	38	40-70	100 Kg	20	10,30
10815010 001	184-M22	47	60	35	Ø35	100	Ø27	23	122	M22	38	45-80	160 Kg	10	7,30
10815015 001	184-M27	52	67	40	Ø40	110	Ø30	28	141	M27	44	55-95	260 Kg	10	10,50

Finishing: Zincato / Galvanized

Categoria commerciale: 1A

La portata è riferita ad una coppia di cardini nel caso di peso uniformemente distribuito in un'anta con L=H.
Weight bearing capacity refers to a pair of hinges mounted on a gate with weight uniformly distributed on a leaf with proportions L=H.

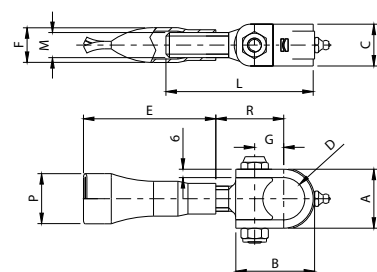

185

Corpo cardine a fascetta con ingrassatore per barre filettate

Clamp-hinge body with greaser for threaded bars
Corps gond à collier avec graisseur pour barres filetéés
Halseisenbandkörper mit Schmierbüchse für Profile mit Gewinde
Cuerpo bisagra de abrazadera con engrasador para varillas roscadas
Корпус петли с полосой с масляной для резьбовых стержней



CODE	ART.	A	B	C	D	F	G	L	M	Portata Capacity	Box info	
											Pcs per pack	Kg
10817505 001	185-M18	42	56	30	Ø30	30	21	81	M18	100 Kg	8	4,10
10817510 001	185-M22	47	60	35	Ø35	35	23	85	M22	160 Kg	6	4,20
10817515 001	185-M27	52	67	40	Ø40	40	28	95	M27	260 Kg	6	5,30

Finishing: Zincato / Galvanized

Categoria commerciale: 1A

La portata è riferita ad una coppia di cardini nel caso di peso uniformemente distribuito in un'anta con L=H.
Weight bearing capacity refers to a pair of hinges mounted on a gate with weight uniformly distributed on a leaf with proportions L=H.

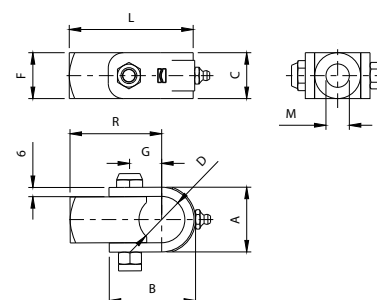

182

Cardine a fascetta con ingrassatore e dado regolabile

Clamp-hinge with greaser and adjustable nut
Gond à collier avec graisseur et écrou réglable
Halseisenband mit Schmierbüchse und verstellbarer Mutter
Bisagra de abrazadera con engrasador y tuerca regulable
Петля с полосой с масляной и регулируемой гайкой



CODE	ART.	A	B	C	D	E	F	G	L	M	R	Portata Capacity	Box info		
													Pcs per pack	Kg	
10814505 001	182-M18	42	56	30	Ø30	17	Ø40	21	106	M18	55-85	27	100 Kg	20	9,70
10814510 001	182-M22	47	60	35	Ø35	20	Ø49	23	122	M22	64-100	30	160 Kg	10	7,10
10814515 001	182-M27	52	67	40	Ø40	25	Ø62	28	141	M27	75-115	40	260 Kg	10	11,70

Finishing: Zincato / Galvanized

Categoria commerciale: 1A

La portata è riferita ad una coppia di cardini nel caso di peso uniformemente distribuito in un'anta con L=H.
Weight bearing capacity refers to a pair of hinges mounted on a gate with weight uniformly distributed on a leaf with proportions L=H.

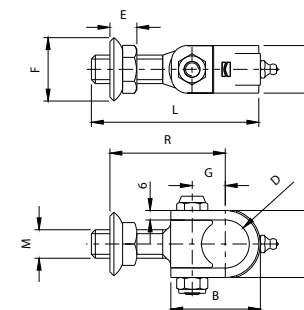

Mounting instructions art. 182

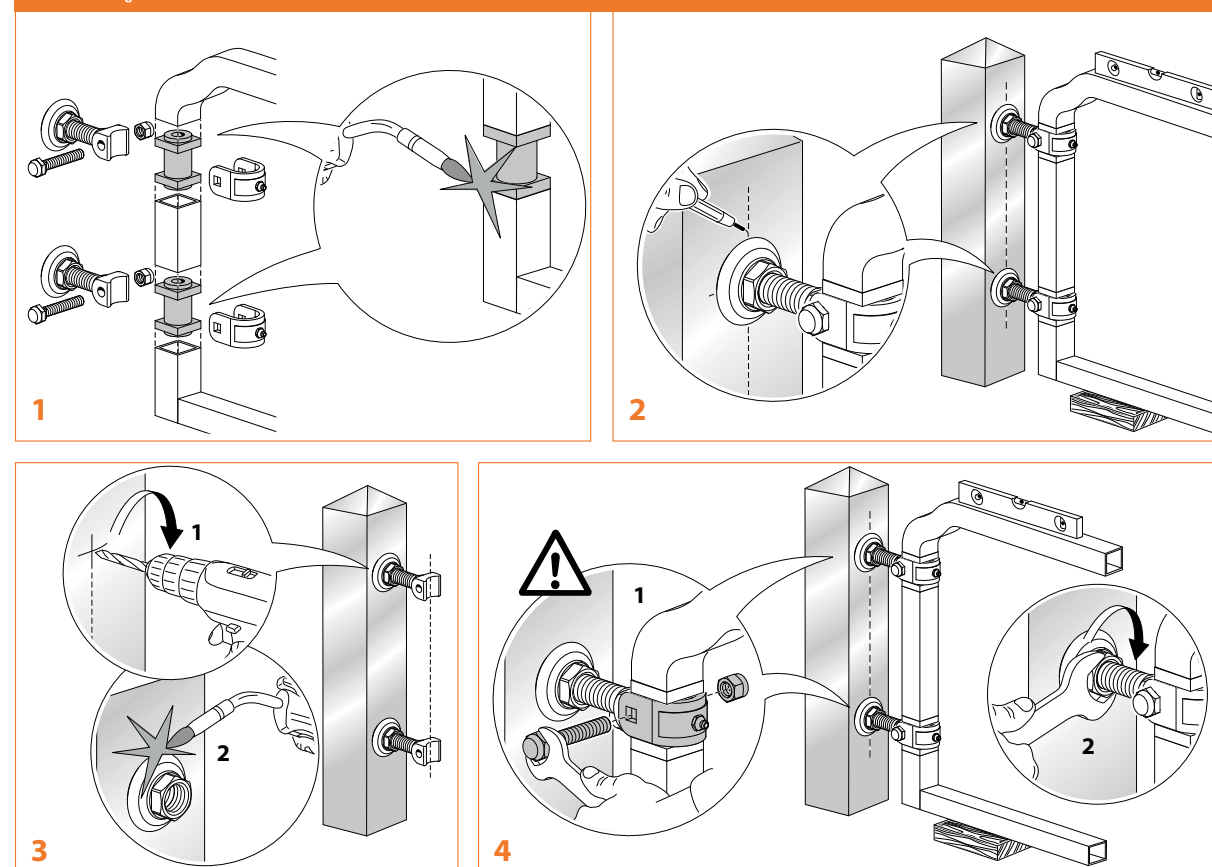



186

Cardine a fascetta con ingrassatore e piastra con dado regolabile

Clamp-hinge with greaser and plate with adjustable nut
Gond à collier avec graisseur et platine avec écrou réglable
Halseisenband mit Schmierbüchse und Platte mit verstellbarer Mutter
Bisagra de abrazadera con engrasador y placa con tuerca regulable
Петля с полосой с масленкой и пластиной с регулируемой гайкой



CODE	ART.	A	B	C	D	E	F	G	I	L	M	R	Portata Capacity	Box info		
														Pcs per pack	Kg	
10815505 001	186-M18	42	56	30	Ø30	100	Ø11	21	65	106	M18	55-85	32	100 Kg	20	16,60
10815510 001	186-M22	47	60	35	Ø35	100	Ø11	23	65	122	M22	64-100	36	160 Kg	10	10,30
10815515 001	186-M27	52	67	40	Ø40	130	Ø13	28	90	141	M27	75-115	41	260 Kg	10	16,70

Finishing: Zincato / Galvanized

La portata è riferita ad una coppia di cardini nel caso di peso uniformemente distribuito in un'anta con L=H.
Weight bearing capacity refers to a pair of hinges mounted on a gate with weight uniformly distributed on a leaf with proportions L=H.

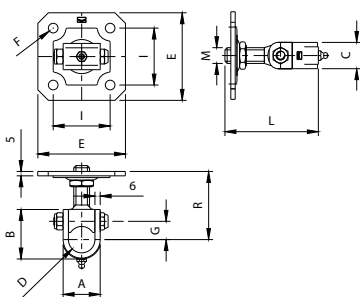

Peso uniformemente distribuito
Equally distributed weight

Categoria commerciale: 1A

188

Cardine a fascetta con ingrassatore e piastra con bussola

Clamp-hinge with greaser and plate with bush
Gond à collier avec graisseur et platine avec douille
Halseisenband mit Schmierbüchse und Platte mit Buchse
Bisagra de abrazadera con engrasador y placa con casquillo
Петля с полосой с масленкой и пластиной со втулкой



CODE	ART.	A	B	C	D	E	F	G	I	L	M	R	Portata Capacity	Box info	
														Pcs per pack	Kg
10816005 001	188-M18	42	56	30	Ø30	100	Ø11	21	65	106	M18	55-85	100 Kg	20	16,60
10816010 001	188-M22	47	60	35	Ø35	100	Ø11	23	65	122	M22	64-100	160 Kg	10	10,30
10816015 001	188-M27	52	67	40	Ø40	130	Ø13	28	90	141	M27	75-115	260 Kg	10	16,70

Finishing: Zincato / Galvanized

La portata è riferita ad una coppia di cardini nel caso di peso uniformemente distribuito in un'anta con L=H.
Weight bearing capacity refers to a pair of hinges mounted on a gate with weight uniformly distributed on a leaf with proportions L=H.

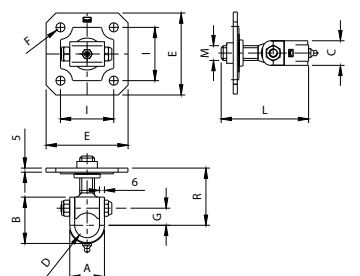

Peso uniformemente distribuito
Equally distributed weight

Categoria commerciale: 1A

189

Dado per cardini

Nut for hinges
Écrou pour gonds
Mutter für Torbänder
Tuerca para bisagras
Гайка для петель



CODE	ART.	A	B	M	R	Box info	
						Pcs per pack	Kg
10822018 001	189-M18	9	27	M18	27	50	1,40
10822020 001	189-M20	10	30	M20	30	50	1,70
10822022 001	189-M22	10	32	M22	32	50	1,90
10822024 001	189-M24	10	36	M24	36	50	2,50
10822027 001	189-M27	12	41	M27	41	50	4,50

Finishing: Zincato / Galvanized

Categoria commerciale: 1A

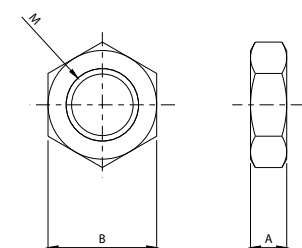

190

Perno forato a base quadrata per cardini a fascetta

Holed pivot with square base for clamp-hinges
Pivot percé avec base carrée pour gonds à collier
Anschweißstück mit Bohrungen und Quadrat-Fuß für Halseisenbänder
Perno perforado de base cuadrada para bisagras de abrazadera
Штифт с отверстиями с квадратным основанием для петель с полосой



CODE	ART.	Size	A	B	D	F	G	H	Tubolare	Box info	
										Pcs per pack	Kg
10816505	190-30	30x30	30	32	Ø29	Ø24	Ø12	62	30x30x3	20	6,90
10816510	190-35	35x35	35	37	Ø34	Ø29	Ø14	67	35x35x3	10	5,30
10816515	190-40	40x40	40	42	Ø39	Ø34	Ø16	72	40x40x3	10	7,20

Finishing: Non zincato / Not galvanized

Categoria commerciale: 1A

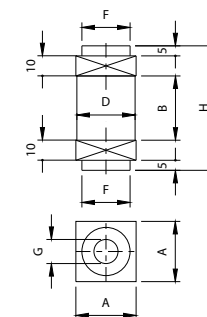

192

Perno maggiorato forato a base quadrata per cardini a fascetta

Oversize holed pivot with square base for clamp-hinges
Pivot plus grand percé avec base carrée pour gonds à collier
Größer Anschweißstück mit Bohrungen und Quadrat-Fuß für Halseisenbänder
Perno sobredimensionado perforado de base cuadrada para bisagras de abrazadera
Увеличенный штифт с отверстиями с квадратным основанием для петель с полосой



CODE	ART.	Size	A	B	D	F	G	H	Tubolare	Box info	
										Pcs per pack	Kg
10817005	192-30	35x35	35	32	Ø29	Ø29	Ø12	62	35x35x3	20	8,20
10817010	192-35	40x40	40	37	Ø34	Ø34	Ø16	67	40x40x3	10	5,90
10817015	192-40	50x50	50	42	Ø39	Ø44	Ø18	72	50x50x3	10	9,20

Finishing: Non zincato / Not galvanized

Categoria commerciale: 1A

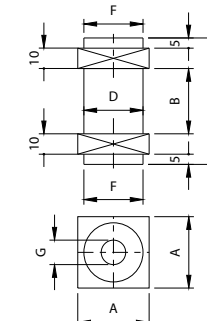

194

Perno inferiore a base quadrata

Bottom pivot with square base
Pivot inférieur avec base carrée
Lagerzapfen mit Quadrat-Fuß
Perno inferior de base cuadrada
Нижний штифт с квадратным основанием



CODE	ART.	A	D	F	Tubolare	Portata con cardine superiore Capacity with top hinge	Box info	
							Pcs per pack	Kg
10818005	194-30x30	30	Ø19	Ø24	30x30x3	280	20	3,70
10818010	194-35x35	35	Ø24	Ø29	35x35x3	350	10	2,70
10818015	194-40x40	40	Ø24	Ø34	40x40x3	550	10	3,20
10818020	194-50x50	50	Ø24	Ø44	50x50x3	550	10	4,50

Finishing: Non zincato / Not galvanized

Categoria commerciale: 1A

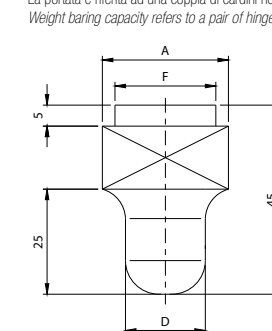

La portata è riferita ad una coppia di cardini nel caso di peso uniformemente distribuito in un'anta con L=H.
Weight bearing capacity refers to a pair of hinges mounted on a gate with weight uniformly distributed on a leaf with proportions L=H.



Peso uniformemente distribuito
Equally distributed weight



194PST

Piastra base inferiore a fissare con perno sferico

Bottom ground plate to be fixed with spherical pivot
Platine de base inférieure à fixer avec pivot sphérique
Bodenplatte zum Anschrauben mit Kugelfzapfen
Placa de base inferior para fijar con perno con bola
Базовая прикрепляемая нижняя пластина со сферическим штифтом



CODE	ART.	R	Portata con cardine superiore Capacity with top hinge	Box info	
				Pcs per pack	Kg
10818101 001	194PST-40x40	10	150 kg	5	3,9

Finishing: Zincato / Galvanized

Categoria commerciale: 1A

La portata è riferita ad una coppia di cardini nel caso di peso uniformemente distribuito in un'anta con L=H.
Weight bearing capacity refers to a pair of hinges mounted on a gate with weight uniformly distributed on a leaf with proportions L=H.

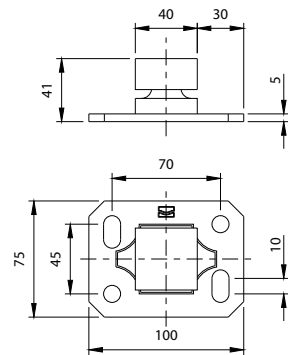

Peso uniformemente distribuito
Equally distributed weight

196

Perno forato a base tonda per cardini a fascetta

Holed pivot with round base for clamp-hinges
Pivot percé avec base ronde pour gonds à collier
Anschweißstück mit Bohrungen und Rund-Fuß für Halseisenbänder
Perno perforado de base redonda para bisagras de abrazadera
Штифт с отверстиями с круглым основанием для петель с полосой



CODE	ART.	B	D	F	G	H	Tubolare	Box info	
								Pcs per pack	Kg
10818505	196-30	50	Ø29	Ø24	Ø12	80	Ø30x3	20	7,30
10818510	196-35	55	Ø34	Ø29	Ø14	85	Ø35x3	10	5,50
10818515	196-40	60	Ø39	Ø34	Ø16	90	Ø40x3	10	7,70

Finishing: Non zincato / Not galvanized

Categoria commerciale: 1A

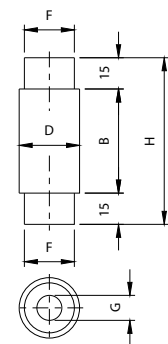

198

Perno inferiore a base tonda

Bottom pivot with round base
Pivot inférieur avec base ronde
Lagerzapfen mit Rund-Fuss
Perno inferior de base redonda
Нижний штифт с круглым основанием



CODE	ART.	A	D	F	Tubolare	Portata con cardine superiore Capacity with top hinge	Box info	
							Pcs per pack	Kg
10819005	198-30	Ø30	Ø19	Ø24	Ø30x3	280	10	1,50
10819010	198-35	Ø35	Ø24	Ø29	Ø35x3	350	10	2,30
10819015	198-40	Ø40	Ø24	Ø34	Ø40x3	550	10	2,80

Finishing: Non zincato / Not galvanized

Categoria commerciale: 1A

La portata è riferita ad una coppia di cardini nel caso di peso uniformemente distribuito in un'anta con L=H.
Weight bearing capacity refers to a pair of hinges mounted on a gate with weight uniformly distributed on a leaf with proportions L=H.

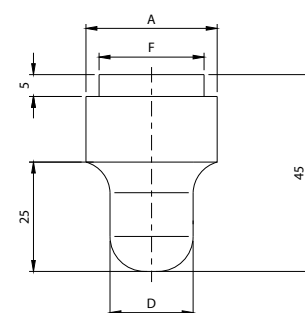

Peso uniformemente distribuito
Equally distributed weight

282

Cardine "Giuliano"

Hinge "Giuliano"
Gond "Giuliano"
Torband "Giuliano"
Bisagra "Giuliano"
Петля "Giuliano"



CODE	ART.	R	Portata Capacity	Box info	
				Pcs per pack	Kg
10812005 001	282-40x40	71-84	400 kg	10	17,6

Finishing: Zincato / Galvanized

Categoria commerciale: 1A

La portata è riferita ad una coppia di cardini nel caso di peso uniformemente distribuito in un'anta con L=H.
Weight bearing capacity refers to a pair of hinges mounted on a gate with weight uniformly distributed on a leaf with proportions L=H.

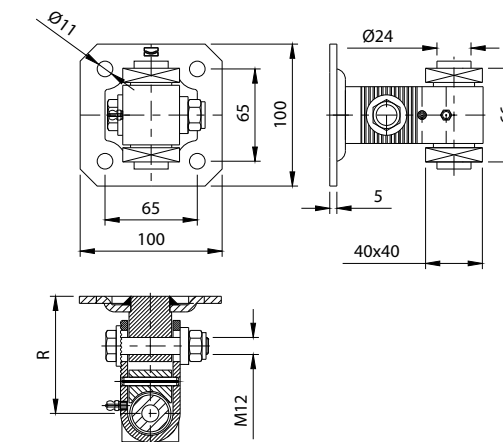

Peso uniformemente distribuito
Equally distributed weight

285

Kit completo cardine "Giuliano"

Kit for hinge "Giuliano"
Kit complet gond "Giuliano"
Satz Torband "Giuliano"
Kit completo bisagra "Giuliano"
Комплект для петли "Giuliano"



CODE	ART.	R	Pcs per pack	Box info	
				Pcs per pack	Kg
10813005 001	285-40x40	71-81	2	6,1	

Finishing: Zincato / Galvanized

Categoria commerciale: 1A

La portata è riferita ad una coppia di cardini nel caso di peso uniformemente distribuito in un'anta con L=H.
Weight bearing capacity refers to a pair of hinges mounted on a gate with weight uniformly distributed on a leaf with proportions L=H.

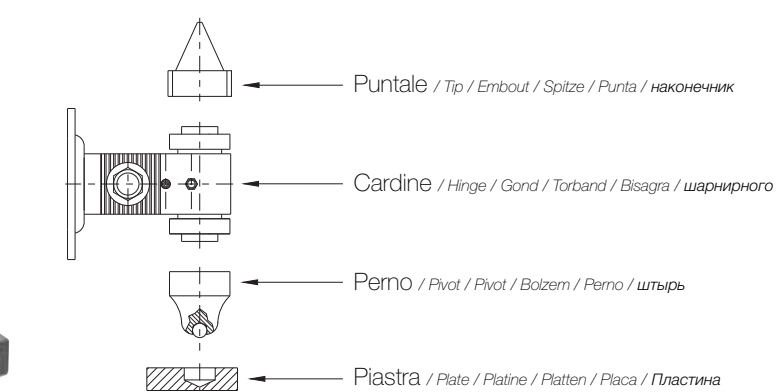

Peso uniformemente distribuito
Equally distributed weight



EE BOX B

Gruppo cassa di fondazione cataforesi
compresa di kit bracci e leverismi

Foundation box cataphoresis, arm kit included
Boîtier de fondation cataforesis avec kit bras et leviers
Kataphorese Fundamentkasten, inklusive Arm Kit
Grupo caja de fundación cataforesis con kit brazos y cammas
катафорез основной коробка, комплект рука включены



CODE	ART.	Box info	
		Pcs per pack	Kg
GEE000BXN0B00	EE-BOX-B	1	11,0

Categoria commerciale: 8i

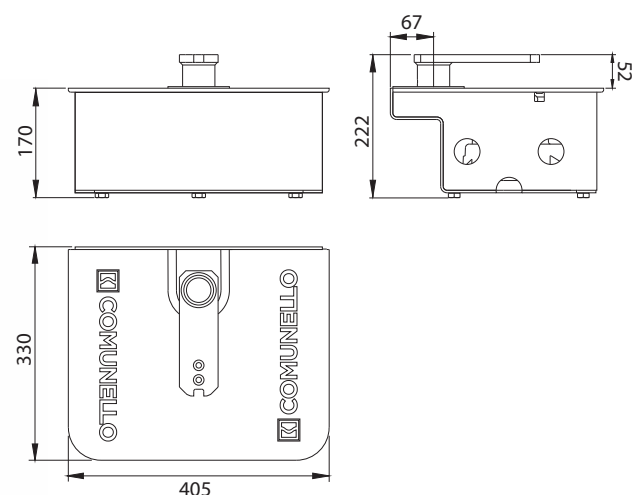

EE BOX i

Gruppo cassa di fondazione inox
compresa di kit bracci e leverismi

Foundation box inox, arm kit included
Boîtier de fondation en acier inoxydable avec kit bras et leviers
Stahlfundamentkasten, inklusive Arm Kit
Grupo caja de fundación en acero inoxidable con kit brazos y cammas
стали основной коробка, комплект рука включены



CODE	ART.	Box info	
		Pcs per pack	Kg
GEE000BXNIS00	EE-BOX-i	1	11,5

Categoria commerciale: 8i

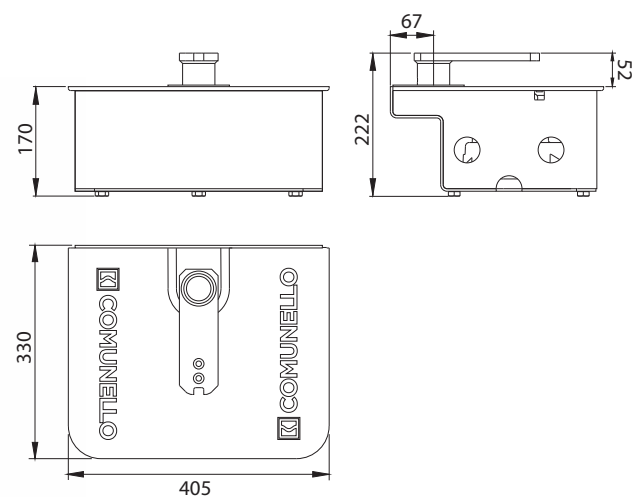

Mounting instructions art. EE BOX B / EE BOX i

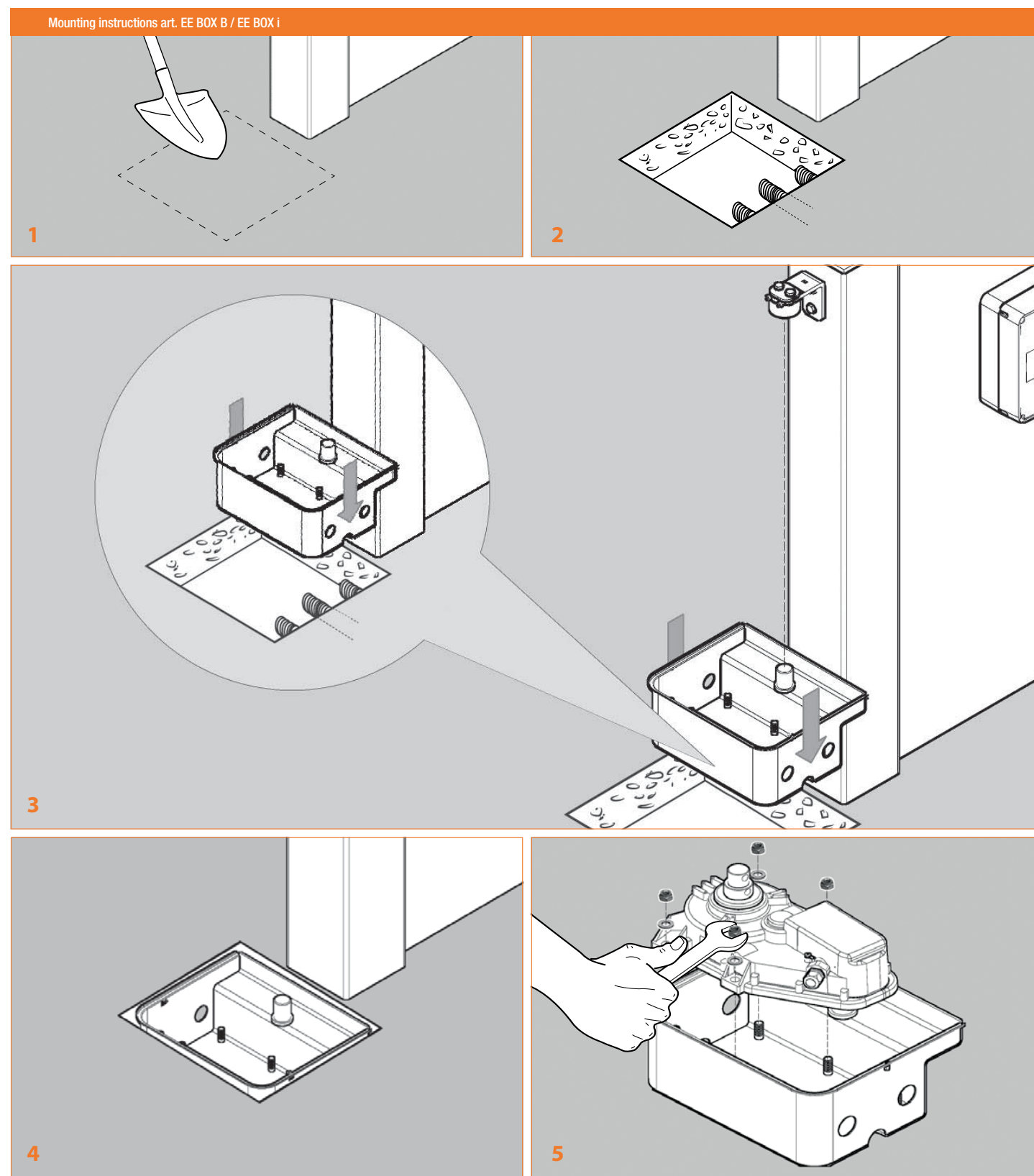



166

Battente d'arresto a fissare
 Stop batten to be fixed
 Battent d'arrêt à fixer
 Aufaufschuh zum Anschrauben
 Tope para fijar
 Прикрепляемый стопор



CODE	ART.	Size	A	B	C	D	E	F	H	L	M	N	Box info	
													Pcs per pack	Kg
10704601 001	166P	Piccolo	120	100	95	75	21	Ø9	42	34	100	70	25	7,40
10704602 001	166G	Grande	160	130	125	100	23	Ø11	48	40	130	90	10	4,80

Finishing: Zincato / Galvanized

Categoria commerciale: 1G

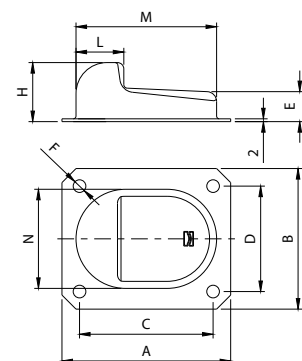

169

Battente d'arresto a cementare
 Stop batten to be cemented
 Battent d'arrêt à sceller
 Aufaufschuh zum Ausbetonieren
 Tope para cementar
 Цементируемый стопор



CODE	ART.	Pcs per pack	Box info	
			Pcs per pack	Kg
10700905 001	169	25	25	7,9

Finishing: Zincato / Galvanized

Categoria commerciale: 1G

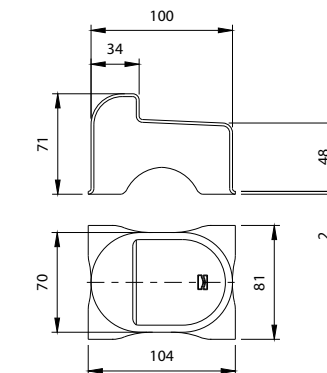

167

Battente d'arresto a cementare
 Stop batten to be cemented
 Battent d'arrêt à sceller
 Aufaufschuh zum Ausbetonieren
 Tope para cementar
 Цементируемый стопор



CODE	ART.	Box info	
		Pcs per pack	Kg
10700705 001	167	10	12,2

Finishing: Zincato / Galvanized

Categoria commerciale: 1G

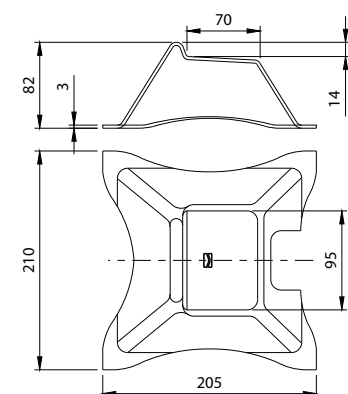

Mounting instructions art. 169

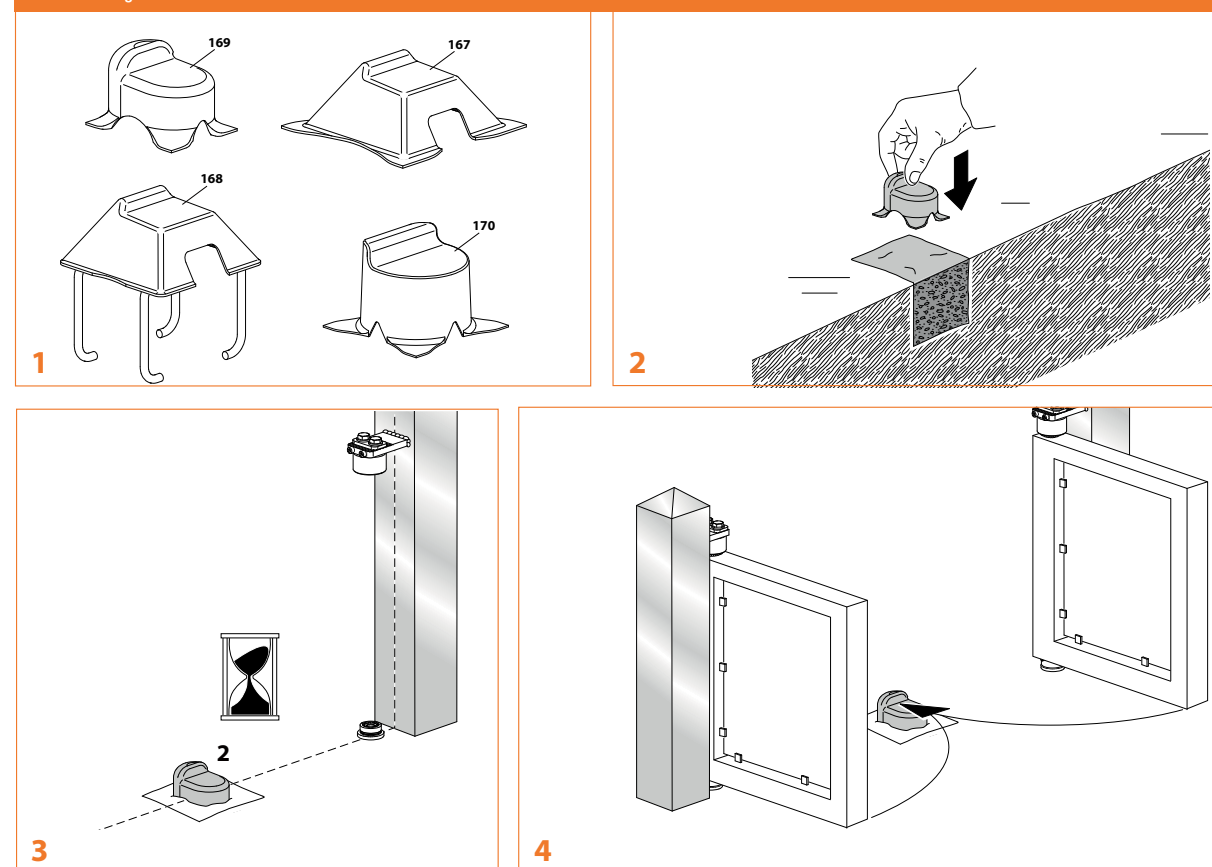

168

Battente d'arresto a cementare con ancoranti
 Stop batten to be cemented with tie rods
 Battent d'arrêt à sceller avec tirants
 Aufaufschuh zum Ausbetonieren mit Ankern
 Tope para cementar con anclajes
 Цементируемый стопор с анкерными креплениями



CODE	ART.	Box info	
		Pcs per pack	Kg
10700805 001	168	4	6,4

Finishing: Zincato / Galvanized

Categoria commerciale: 1G

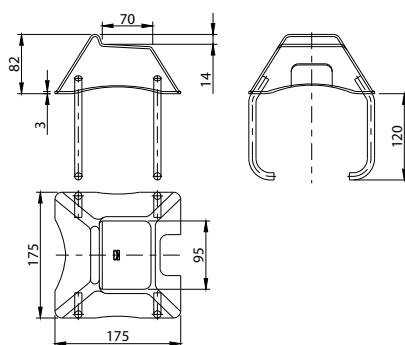



170

Battente d'arresto a cementare
Stop batten to be cemented
Battent d'arrêt à sceller
Auflaufschuh zum Ausbetonieren
Tope para cementar
Цементируемый стопор



CODE	ART.	Box info	
		Pcs per pack	Kg
10701005 001	170	25	8,5

Finishing: Zincato / Galvanized Categoria commerciale: 1G

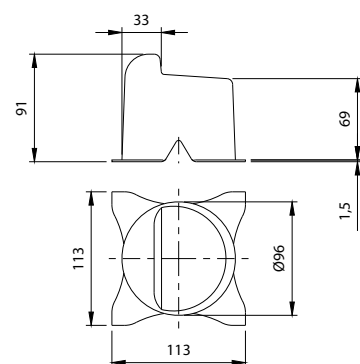

171

Battente d'arresto a fissare
Stop batten to be fixed
Battent d'arrêt à fixer
Auflaufschuh zum Anschrauben
Tope para fijar
Прикрепляемый стопор



CODE	ART.	Box info	
		Pcs per pack	Kg
10701205 001	171	10	8,2

Finishing: Zincato / Galvanized Categoria commerciale: 1G

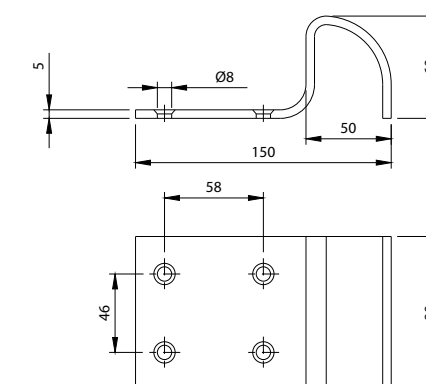

170i

Battente d'arresto a cementare
Stop batten to be cemented
Battent d'arrêt à sceller
Auflaufschuh zum Ausbetonieren
Tope para cementar
Цементируемый стопор



CODE	ART.	Box info	
		Pcs per pack	Kg
10701105	170i	5	1,8

Finishing: Inox / Stainless steel Categoria commerciale: 2G

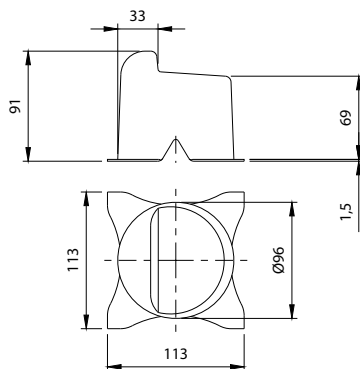

Mounting instructions art. 171

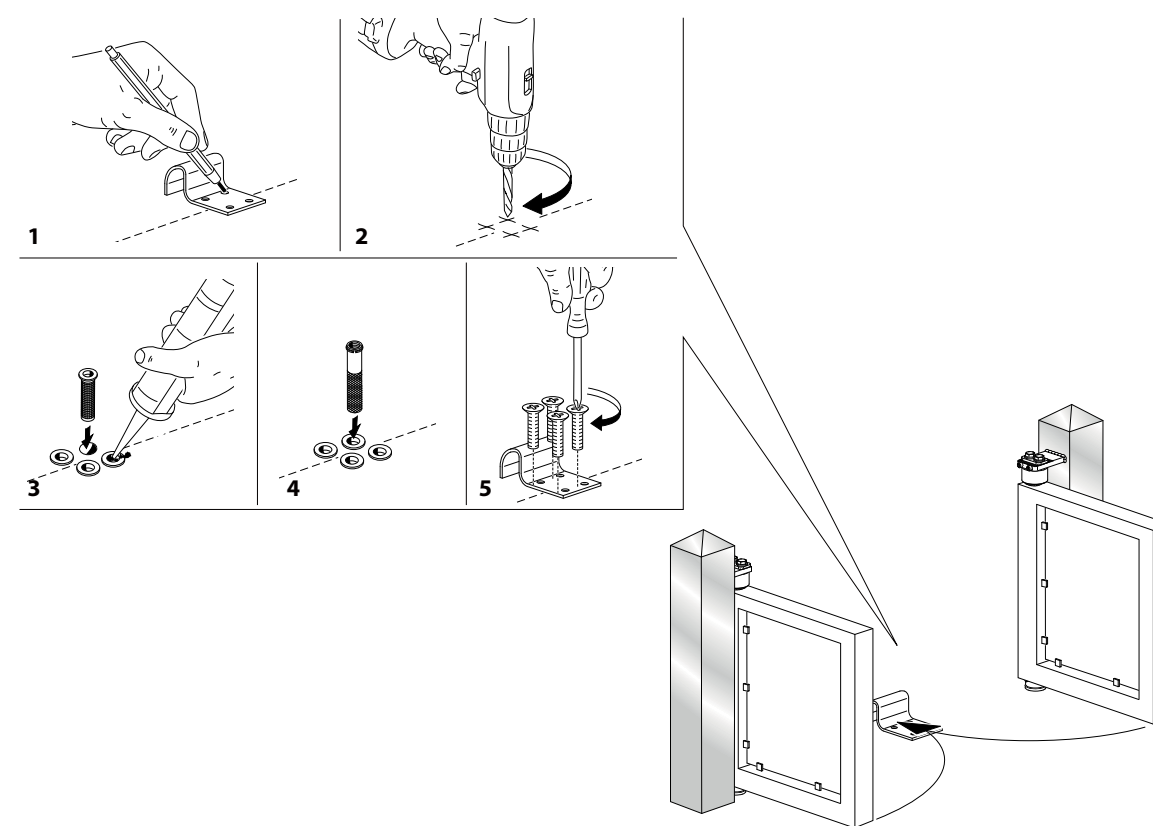



COPRI PILASTRI

PILLAR COVER

02



165

Copri pilastro quadrato grezzo
Square pillar cover raw
Couvre pilastre carré brut
Viereckiger Pfostendeckel
Cubrepilar cuadrado bruto
Необработанный квадратный концевик для стойки



CODE	ART.	A	B	H	S	Box info	
						Pcs per pack	Kg
12100505	165-30	35	6,5	12	1,8	50	1,4
12100510	165-40	45	6	12	1,8	50	2,1
12100515	165-50	55	6	13	1,8	50	3,1
12100520	165-60	65	6,5	16	1,8	50	4,5
12100525	165-80	85	6,5	16,5	1,8	50	6,7
12100530	165-100	105	6,5	19	1,8	50	9,6
12100535	165-120	125	8	26	2	25	7,6
12100540	165-150	155	6,5	24,5	2	25	11,1
12100550	165-200	205	6	29	2	20	15,5

Finishing: Non zincato / Not galvanized

Categoria commerciale: 1G

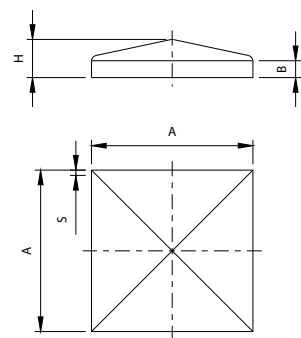

165T

Copri pilastro tondo
Round pillar cover
Couvre pilastre rond
Runder Pfostendeckel
Cubrepilar redondo
Необработанный квадратный концевик для стойки
Оцинкованный круглый концевик для стойки



CODE	ART.	D	In	B	H	Box info	
						Pcs per pack	Kg
12100805	165T-30	Ø30,3	1 3/16"	9	16,5	50	1,1
12100810	165T-33	Ø33,8	1 11/32"	9	17	50	1,3
12100815	165T-42	Ø42,7	1 11/16"	9	19	50	1,8
12100820	165T-48	Ø48,5	1 29/32"	9	20	50	2,2
12100830	165T-76	Ø76,5	3"	11	27	50	4,8
12100835	165T-89	Ø89,2	3 1/2"	11	25	50	6,0
12100845	165T-114	Ø114,8	4 17/32"	11	29	25	5,1

Finishing: Non zincato / Not galvanized

Categoria commerciale: 1G

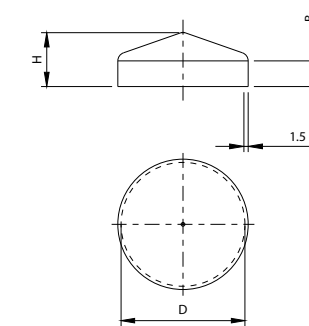

165Z

Copri pilastro quadrato zincato
Square pillar cover galvanized
Couvre pilastre carré zingué
Viereckiger Pfostendeckel Verzinkt
Cubrepilar cuadrado galvanizado
Оцинкованный квадратный концевик для стойки



CODE	ART.	A	B	H	S	Box info	
						Pcs per pack	Kg
12100505 001	165Z-30	35	6,5	12	1,8	50	1,4
12100510 001	165Z-40	45	6	12	1,8	50	2,1
12100515 001	165Z-50	55	6	13	1,8	50	3,1
12100520 001	165Z-60	65	6,5	16	1,8	50	4,5
12100525 001	165Z-80	85	6,5	16,5	1,8	50	6,7
12100530 001	165Z-100	105	6,5	19	1,8	50	9,6
12100535 001	165Z-120	125	8	26	2	25	7,6
12100540 001	165Z-150	155	6,5	24,5	2	25	11,1
12100550 001	165Z-200	205	6	29	2	20	15,5

Finishing: Zincato / Galvanized

Categoria commerciale: 1G

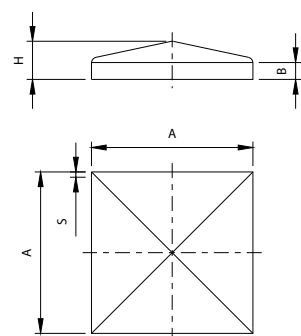

165i

Copri pilastro quadrato
Square pillar cover
Couvre pilastre carré
Viereckiger Pfostendeckel
Cubrepilar cuadrado
Квадратный концевик для стойки



CODE	ART.	A	B	H	S	Box info	
						Pcs per pack	Kg
12100705	165i-30	35	6,5	12	1,5	10	0,3
12100710	165i-40	45	6	12	1,5	10	0,4
12100715	165i-50	55	6	13	1,5	10	0,6
12100720	165i-60	65	6,5	16	1,5	10	0,7
12100725	165i-80	85	6,5	16,5	1,5	6	0,7
12100730	165i-100	105	6,5	19	1,5	6	1,1
12100735	165i-120	125	8	26	1,5	6	1,3
12100740	165i-150	155	6,5	24,5	1,5	2	0,7

Finishing: Inox / Stainless steel

Categoria commerciale: 2G

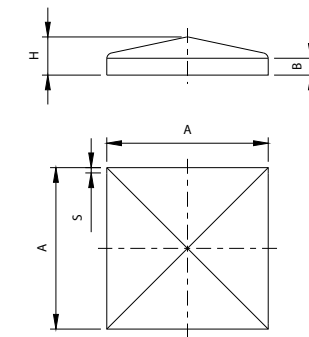



ARRESTI

STOPS

03



199

Incontro superiore con
tappo ammortizzatore

Upper end with shock absorber cup
Butée supérieure avec bouchon amortisseur
Oberer Auflageschuh mit Schlusdämpfer
Encuentro superior con tapón amortiguador
Верхний упор с амортизирующим буфером



CODE	ART.	Size	A	B	C	E	L	Box info	
								Pcs per pack	Kg
10704701	199-40	Piccolo	50	42	59	24	45	6	1,6
10704705	199-50	Medio	60	52	69	30	50	6	2,3
10704710	199-60	Grande	70	62	79	35	60	6	3,0

Finishing: Non zincato / Not galvanized

Categoria commerciale: 1G

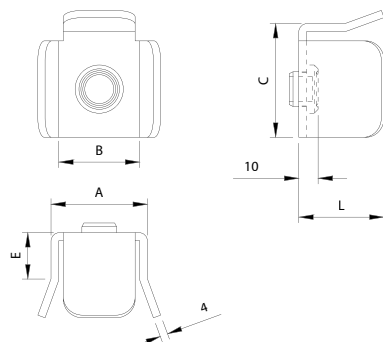

202

Arresto di fine corsa con base
a fissare

Runaway stop to be screwed
Boutoir de fin de course avec base à visser
Torenpuffer mit Befestigungsplatte zum Anschrauben
Tope de final de carrera con base para fijar
Стопор конца хода с прикрепляемым основанием



CODE	ART.	R	Box info	
			Pcs per pack	Kg
10701810 001	202		10	7,4

Finishing: Zincato / Galvanized

Categoria commerciale: 1G

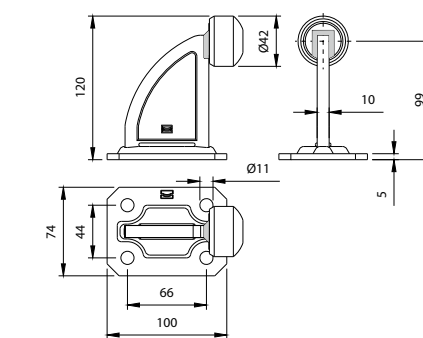

200

Arresto di fine corsa

Runaway stop
Boutoir de fin de course
Torenpuffer
Tope de final de carrera
Стопор конца хода



CODE	ART.	Size	A	B	D	H	L	S	Box info	
									Pcs per pack	Kg
10701505 001	200P	Piccolo	50	27	Ø37	96	77	8	30	7,9
10701510 001	200G	Grande	70	28	Ø42	120	98	10	15	6,9

Finishing: Zincato / Galvanized

Categoria commerciale: 1G

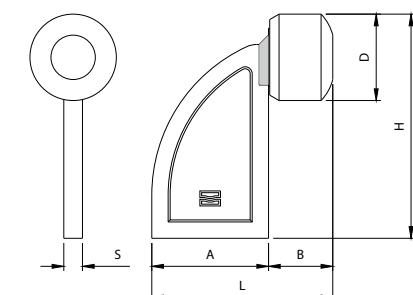

202F-A

Arresto di fine corsa ammortizzato
con base a fissare

Damped runaway stop to be screwed
Boutoir de fin de course amorti avec base à visser
Torenpuffer mit Platte zum Anschrauben
Tope de final de carrera amortiguado con base para fijar
Амортизированный стопор конца хода с прикрепляемым основанием



CODE	ART.	R	Box info	
			Pcs per pack	Kg
10704201 001	202F-A		4	5,6

Finishing: Zincato / Galvanized

Categoria commerciale: 1G

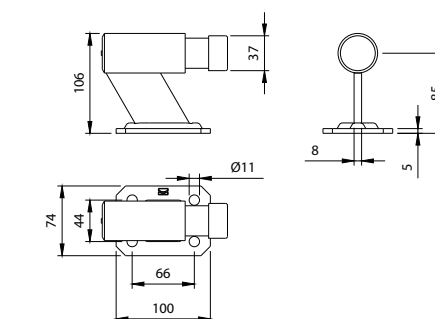

200i-G

Arresto di fine corsa

Runaway stop
Boutoir de fin de course
Torenpuffer
Tope de final de carrera
Стопор конца хода



CODE	ART.	Size	A	B	D	H	L	S	Box info	
									Pcs per pack	Kg
10701610	200i-G	Grande	70	21	Ø42	115	91	10	5	2,9

Finishing: Inox / Stainless steel

Categoria commerciale: 2G

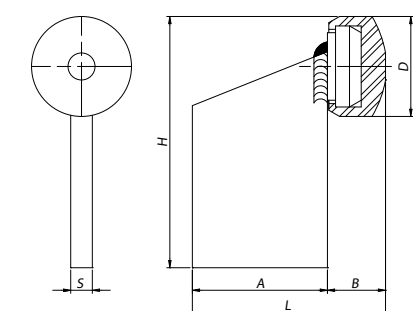

202F-C

Arresto di fine corsa regolabile
a fissare

Adjustable runaway stop to be screwed
Boutoir de fin de course à visser réglable
Verstellbarer Torenpuffer zum Anschrauben
Tope de final de carrera regulable para fijar
Прикрепляемый регулируемый стопор конца хода



CODE	ART.	R	Box info	
			Pcs per pack	Kg
1074401 001	202F-C	70-115	10	12,4

Finishing: Zincato / Galvanized

Categoria commerciale: 1G

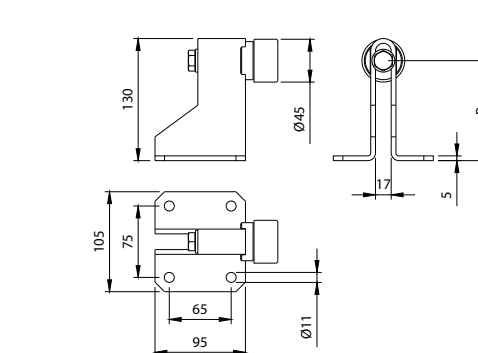



201

Battente "Tris" a fissare tripla funzione
Strike plate to be fastened with triple function
Butée à fixer triple fonction
Aufaufschuh zur Befestigung mit dreifacher Funktion
Tope "tris" para fijar triple función
Упор "трис" прикрепляемый с тройной функцией



CODE	ART.	Box info	
		Pcs per pack	Kg
10701450 001	201	2	2,8

Finishing: Zincato / Galvanized

Categoria commerciale: 1G

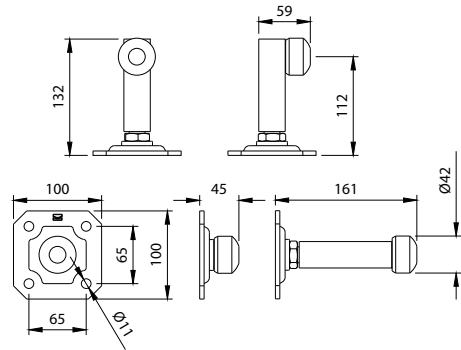

202F-B

Arresto di fine corsa regolabile a fissare per cancelli ad anta
Adjustable runaway stop to be screwed for wing gates
Boutoir de fin de course à visser réglable pour portails à vantaux
Verstellbarer Torenpuffer zum Anschrauben für Flügeltore
Tope de final de carrera regulable para fijar para puertas de hoja
Прикрепляемый регулируемый стопор конца хода для распашных ворот



CODE	ART.	R	Box info	
			Pcs per pack	Kg
10704301 001	202F-B	70-115	4	6,4

Finishing: Zincato / Galvanized

Categoria commerciale: 1G

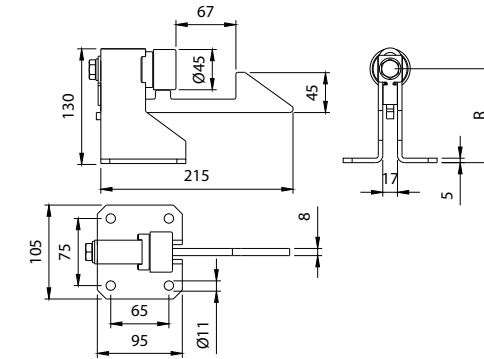

Mounting instructions art. 201

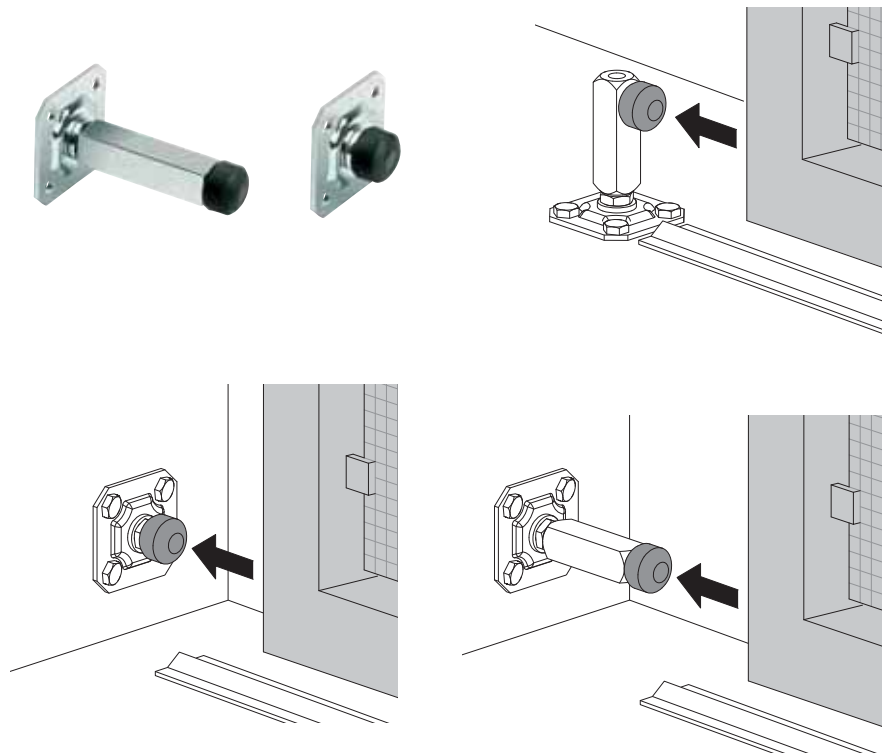

Mounting instructions art. 202F-B

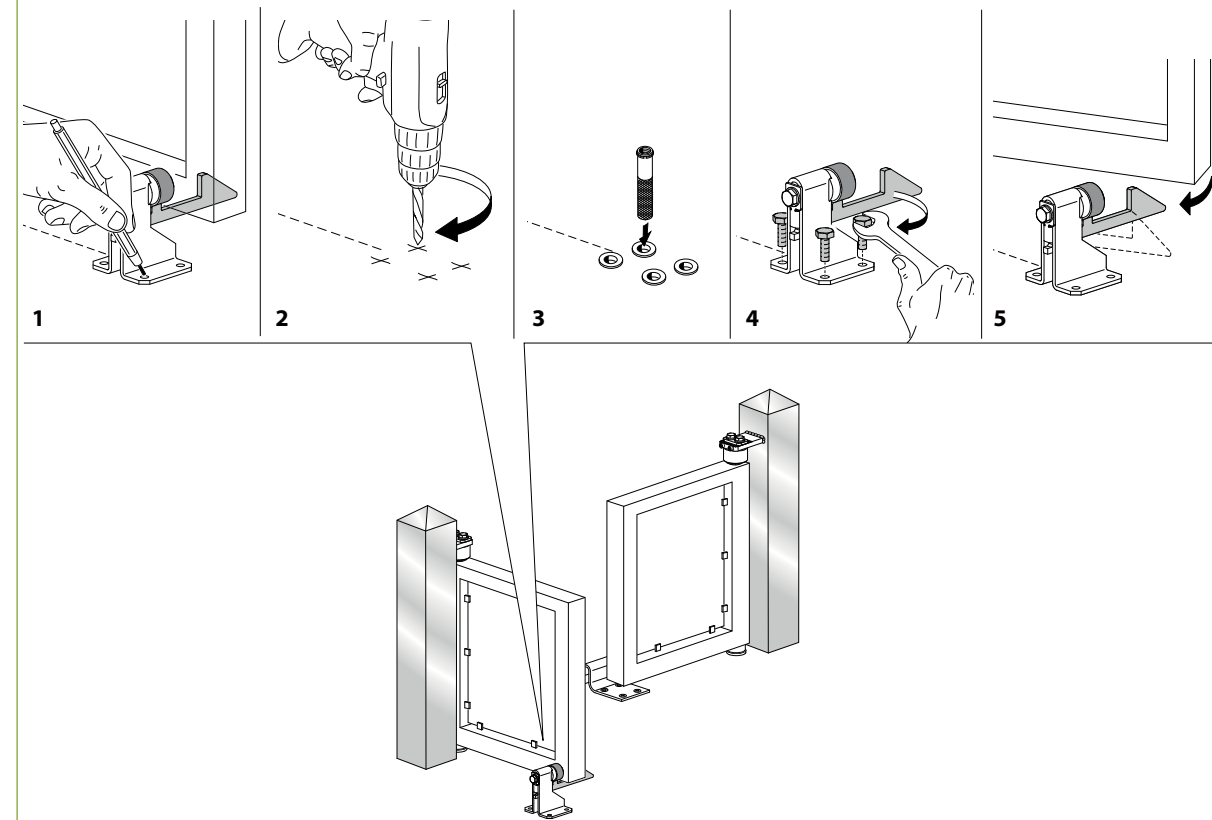



204

Incontro chiuso regolabile con
tappi ammortizzatori

Closed adjustable end with shock absorber cups
Butée fermée réglable avec bouchons amortisseurs
Verstellbarer geschlossener Auflageschuh mit
Schlussdämpfern

Encuentro cerrado regulable con tapones amortiguadores
Закрытый регулируемый упор с амортизирующими
буферами



CODE	ART.	R		Box info	
				Pcs per pack	Kg
10704550 001	204	80-150	10	2	7,3

Finishing: Zincato / Galvanized

Categoria commerciale: 1G

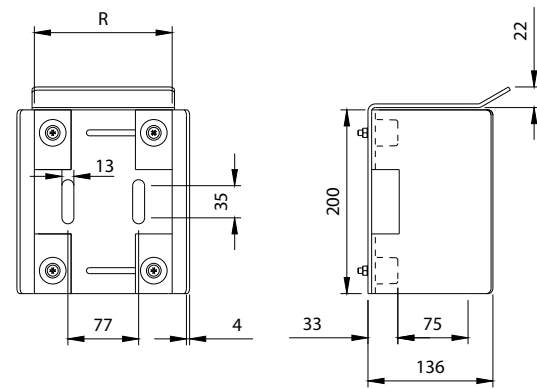

202A

Adattatore in nylon per arresto di
fine corsa a fissare

Nylon adapter for runaway stop to be screwed
Adaptateur en nylon pour butoir de fin de course à visser
Nylon-Passtreck für Befestigungsplatte zum Anschrauben
Adaptador de nylon para tope de fin de carrera para fijar
Прикрепляемый адаптер из нейлона для остановки
в конце хода



CODE	ART.	R		Box info	
				Pcs per pack	Kg
10502101	202A	80-150	10	2	0,9

Finishing: Nylon

Categoria commerciale: 1G

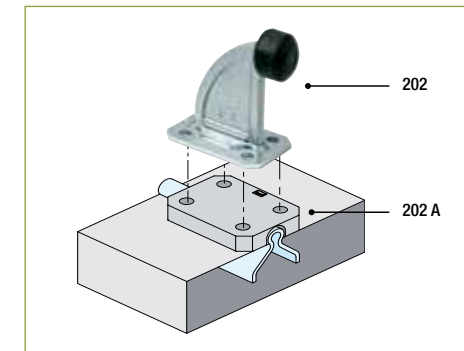
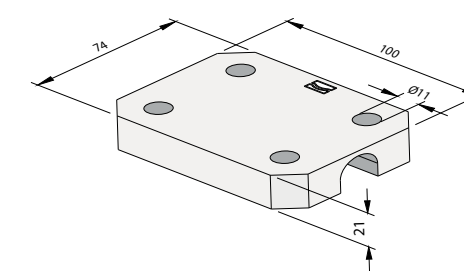

Mounting instructions art. 204

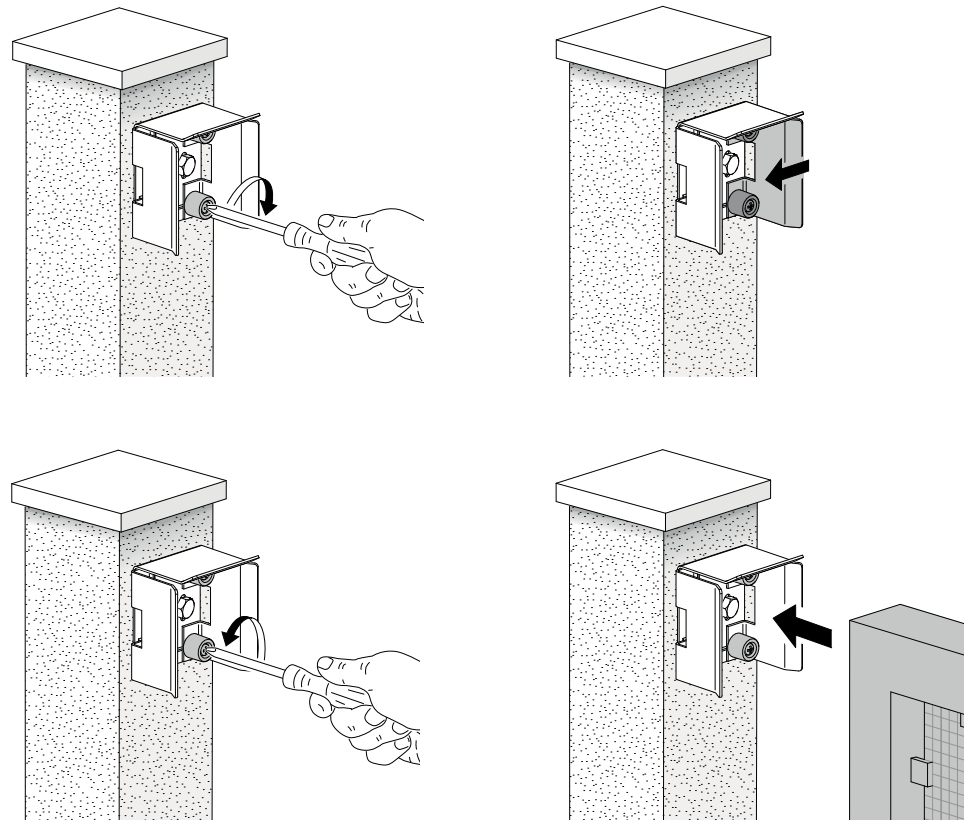

203

Incontro aperto regolabile con
tappi ammortizzatori

Open adjustable end with shock absorber cups
Butée ouverte avec bouchons amortisseurs
Verstellbarer geöffneter Auflageschuh mit
Schlussdämpfern

Encuentro abierto regulable con tapones amortiguadores
Открытый регулируемый упор с амортизирующими
буферами



CODE	ART.	R		Box info	
				Pcs per pack	Kg
10704501 001	203	80-150	10	2	5,8

Finishing: Zincato / Galvanized

Categoria commerciale: 1G

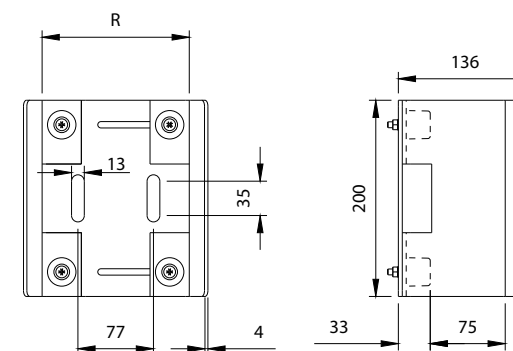



PIASTRE & OLIVE

PLATES & ROLLERS

04



227

Oliva in ottone
Brass roller
Rouleau en laiton
Führungsrolle aus Messing
Rodillo de latón
Латунный наконечник



CODE	ART.	A	D	L		Box info	
						Pcs per pack	Kg
11300505 001	227-30	41	Ø30	74	24	20	6,4
11300510 001	227-42	58	Ø42	98	24	20	13,8

Finishing: Zincato / Galvanized

Categoria commerciale: 1L

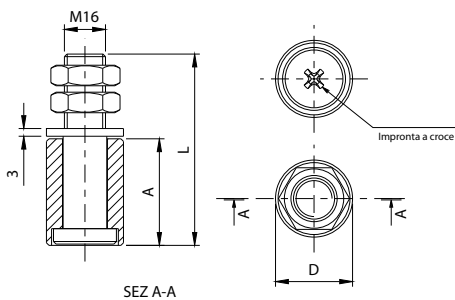

231

Oliva in nylon
Nylon roller
Rouleau en nylon
Nylon-Führungsrolle
Rodillo de nylon
Нейлоновый наконечник



CODE	ART.		Box info	
			Pcs per pack	Kg
11301505 001	231-Ø52	24	20	9,6

Finishing: Zincato / Galvanized

Categoria commerciale: 1L

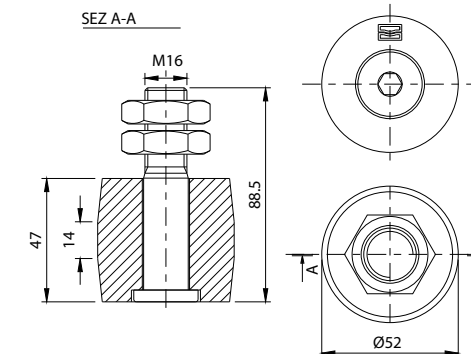

230

Oliva in nylon
Nylon roller
Rouleau en nylon
Nylon-Führungsrolle
Rodillo de nylon
Нейлоновый наконечник



CODE	ART.	A	B	D	I	H	Box info	
							Pcs per pack	Kg
11301005 001	230-25	34	Ø25	63	M14	22	20	2,50
11301010 001	230-30	40	Ø30	74	M16	24	20	3,70
11301015 001	230-40	58	Ø39	98	M16	24	20	5,30
11301017 001	230-41	43	Ø41	74	M16	24	20	4,40
11301020 001	230-42	58	Ø42	98	M16	24	20	5,50

Finishing: Zincato / Galvanized

Categoria commerciale: 1L

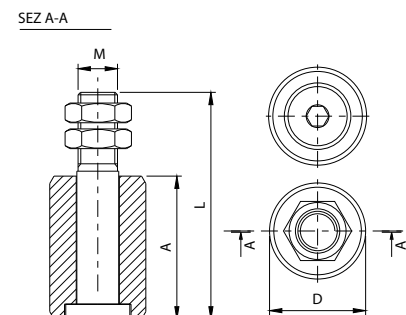

232

Oliva in nylon con protezione antinfortunistica
Nylon roller with accident prevention
Rouleau en nylon pour la prévention des accidents
Nylon-Führungsrolle für die Unfallverhütung
Rodillo de nylon con protección
Нейлоновый наконечник с защитой от несчастных случаев



CODE	ART.	A	B	D	I	H	Box info	
							Pcs per pack	Kg
11302210 001	232-30	40	Ø30	3	84	24	20	4,40
11302215 001	232-40	58	Ø39	7,5	98	24	20	5,90

Finishing: Zincato / Galvanized

Categoria commerciale: 1L

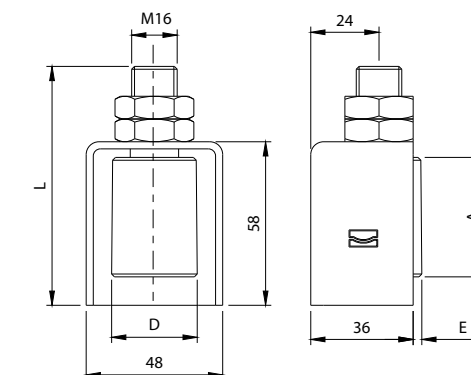

230i

Oliva in nylon
Nylon roller
Rouleau en nylon
Nylon-Führungsrolle
Rodillo de nylon
Нейлоновый наконечник



CODE	ART.	A	D	L	M		Box info	
							Pcs per pack	Kg
11301310	230i-30	40	Ø30	74	M16	24	8	1,50
11301315	230i-40	58	Ø39	98	M16	24	4	1,00

Finishing: Inox / Stainless steel

Categoria commerciale: 2L

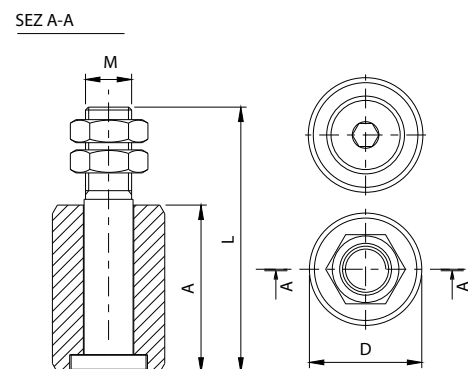

235

Oliva in nylon
Nylon roller
Rouleau en nylon
Nylon-Führungsrolle
Rodillo de nylon
Нейлоновый наконечник



CODE	ART.		Box info	
			Pcs per pack	Kg
11302005 001	235-35	17	20	2,0

Finishing: Zincato / Galvanized

Categoria commerciale: 1L

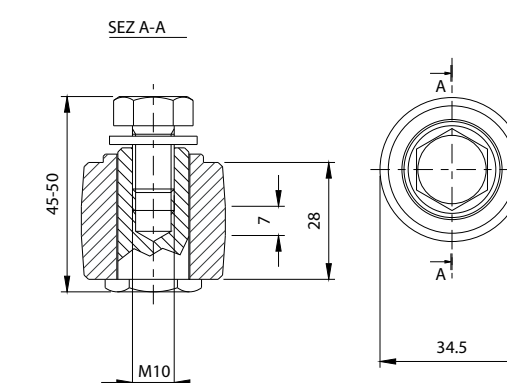

240

Oliva in nylon
Nylon roller
Rouleau en nylon
Nylon-Führungsrolle
Rodillo de nylon
Нейлоновый наконечник



CODE	ART.	17	Box info	
			Pcs per pack	Kg
11302010 001	240-37,5	17	20	2,2

Finishing: Zincato / Galvanized

Categoria commerciale: 1L

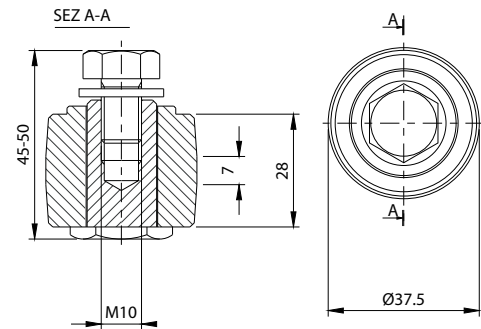

244

Perno con cuscinetto
Pivot with bearing
Pivot avec roulement
Bolzen mit Kugellager
Perno con rodamiento
Штифт с подшипником



CODE	ART.	A	B	D	L	M	1	2	Box info	
									Pcs per pack	Kg
11303505 001	244-25	7	19	Ø24	41	M12	19	15	20	1,30
11303510 001	244-30	9	22	Ø30	45	M14	22	17	20	2,10
11303515 001	244-40	12	24	Ø40	48	M14	22	19	20	3,20

Finishing: Zincato / Galvanized

Categoria commerciale: 1L

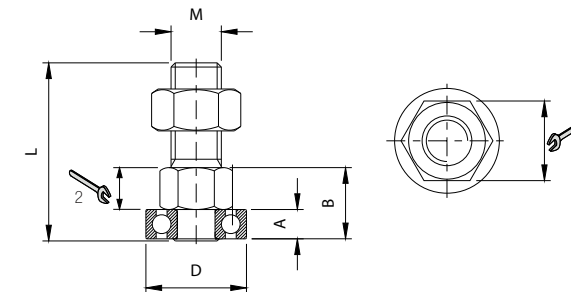

242

Oliva conica in nylon
Nylon conical roller
Rouleau conique en nylon
Nylon-Führungsrolle mit konischem Verlauf
Rodillo cónico de nylon
Нейлоновый конический наконечник



CODE	ART.	17	Box info	
			Pcs per pack	Kg
11302505 001	242-37,5	17	20	2,3

Finishing: Zincato / Galvanized

Categoria commerciale: 1L

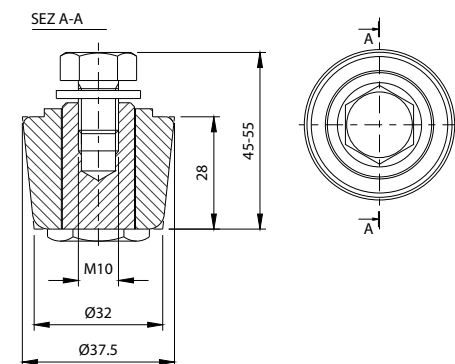

245

Perno con cuscinetto
Pivot with bearing
Pivot avec roulement
Bolzen mit Kugellager
Perno con rodamiento
Штифт с подшипником



CODE	ART.	A	B	D	L	1	2	Box info	
								Pcs per pack	Kg
11304005 001	245-32	10	30	Ø32	60	22	19	20	2,90
11304010 001	245-35	11	30	Ø35	61	22	19	20	3,30
11304015 001	245-42	13	33	Ø42	63	22	19	20	4,10

Finishing: Zincato / Galvanized

Categoria commerciale: 1L

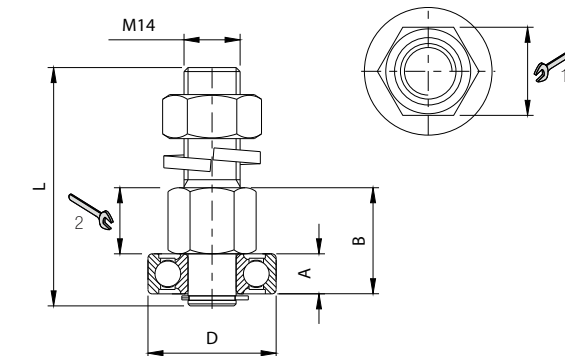

243

Oliva a rullo in nylon
Nylon roller
Rouleau en nylon
Nylon-Führungsrolle
Rodillo de nylon
Нейлоновый роликовый наконечник



CODE	ART.	D	L	M	17	Box info	
						Pcs per pack	Kg
11303005 001	243-25	Ø25	72	M12	19	20	2,30
11303010 001	243-30	Ø30	75	M14	22	20	3,30
11303015 001	243-40	Ø40	75	M14	22	20	3,60

Finishing: Zincato / Galvanized

Categoria commerciale: 1L

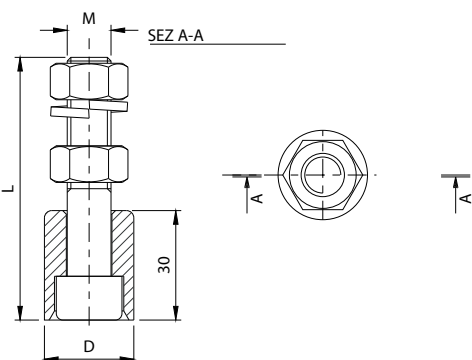

247

Piastra mini guida cancello
Small drive-gate plate
Petite platine guide-portail
Kleiner Führungsbügel
Placa pequeña de guía de la puerta
Пластина минируководящая ворот



CODE	ART.	R	Box info	
			Pcs per pack	Kg
113005005 001	247	30-60	20	9,5

Finishing: Zincato / Galvanized

Categoria commerciale: 1L

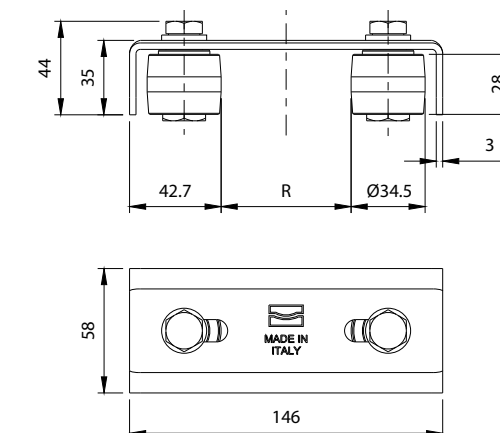



247F

Minipiastra guida cancello
Small drive-gate plate
Petite platine guide-portail
Kleiner Führungsbügel
Placa pequeña de guía de la puerta
Пластина минируководящая ворот



CODE	ART.	R	Box info	
			Pcs per pack	Kg
11305008 001	247 F	0-85	20	9,40

Finishing: Zincato / Galvanized

Categoria commerciale: 1L

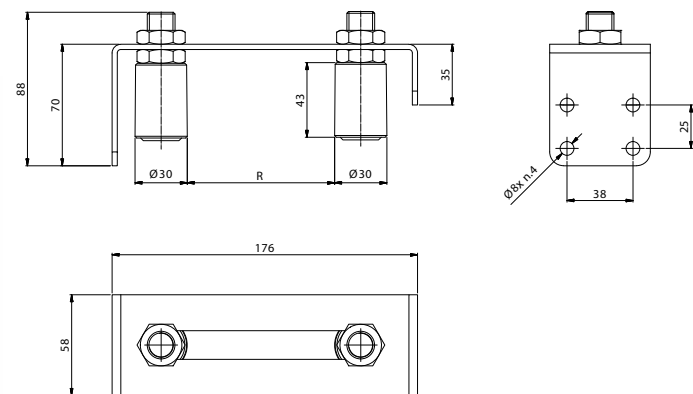

250

Piastra guida cancello regolabile
Drive-gate adjustable plate
Platine guide-portail réglable
Verstellbarer Torführungsbügel
Placa de guía de la puerta regulable
Пластина регулируемая направляющая ворот



CODE	ART.	R	Box info	
			Pcs per pack	Kg
11305505 001	250-220	30-60	10	12,5

Finishing: Zincato / Galvanized

Categoria commerciale: 1L

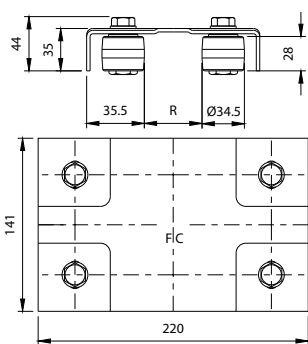

250i

Piastra guida cancello regolabile
Drive-gate adjustable plate
Platine guide-portail réglable
Verstellbarer Torführungsbügel
Placa de guía de la puerta regulable
Пластина регулируемая направляющая ворот



CODE	ART.	R	Box info	
			Pcs per pack	Kg
11305605	250i-220	30-60	1	1,3

Finishing: Inox / Stainless steel

Categoria commerciale: 2L

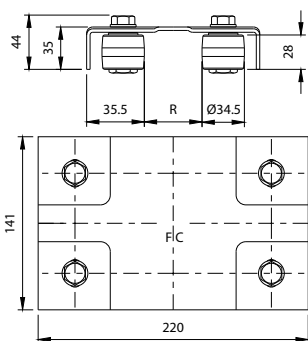

251

Piastra guida cancello regolabile con staffe angolari
Adjustable drive-gate plate with angle-brackets
Platine guide-portail réglable avec plaques d'angle
Verstellbarer Torführungsbügel mit Eckhalterungen
Placa de guía de la puerta regulable con estribos de fijación
Пластина регулируемая направляющая ворот с угловыми скобами



CODE	ART.	Size	A	B	C	D	E	H	L	M	R	Box info	
												Pcs per pack	Kg
11305805 001	251-220	Ø30	70	175	40	Ø30	80-120	85	220	45	0-80	4	10,80
11305810 001	251-300	Ø40	80	230	58	Ø40	80-120	102	300	52	0-120	2	7,50

Finishing: Zincato / Galvanized

Categoria commerciale: 1L

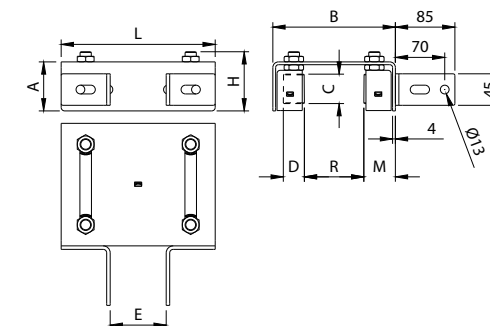

Mounting instructions art. 251

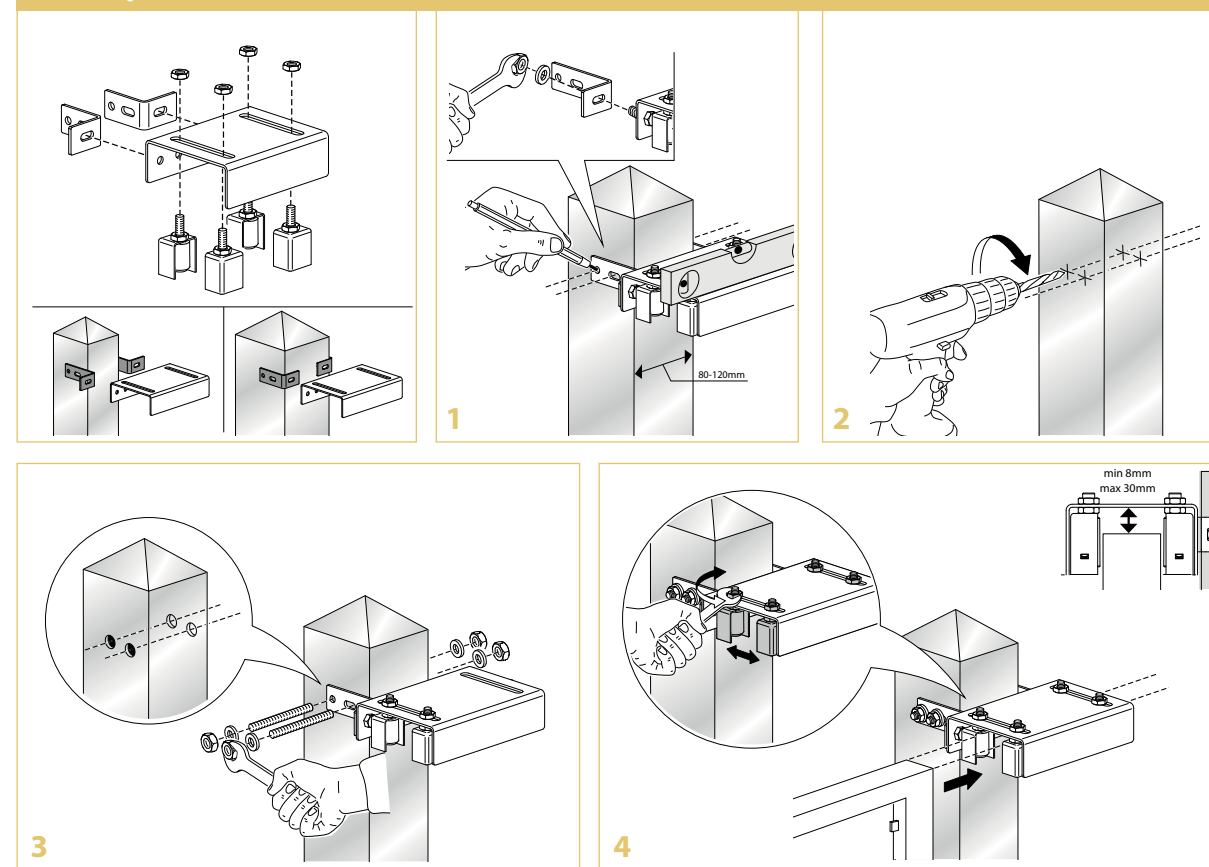



252

Piastra doppia regolazione a fissare per cancelli con doppia colonna
 Double adjustment plate to be screwed for gates with 2 columns
 Platine double réglage à visser pour portails avec 2 colonnes
 Platte zum Anschrauben mit Doppelverstellung für Tore mit zwei Pfeiler
 Placa doble regulación para fijar para puertas con dos columnas
 Прикрепляемая пластина с двойным регулированием для ворот с двумя стойками

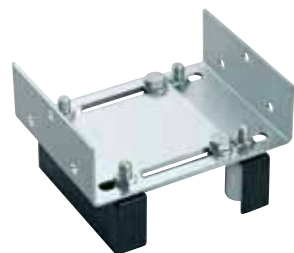

CODE	ART.	Size	E	R	Box info	
					Pcs per pack	Kg
11306205 001	252-200	Ø 40	210-360	0-300	1	4,1

Finishing: Zincato / Galvanized

Categoria commerciale: 1L

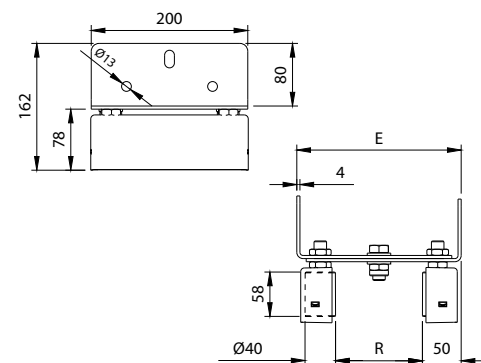

Mounting instructions art. 252

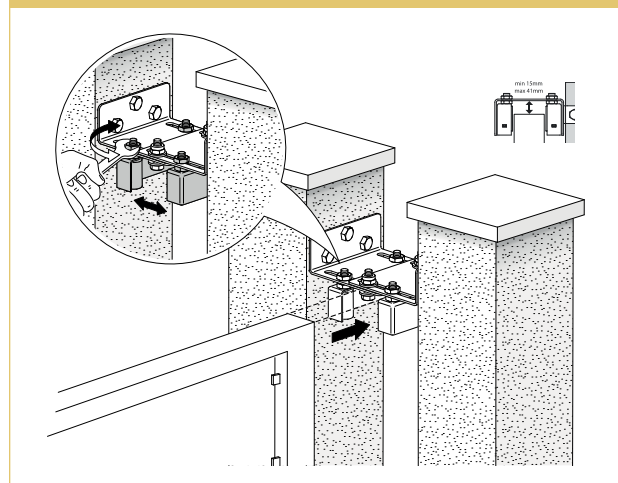

253

Maxi rullo in nylon a fissare
 Big nylon-roller to be screwed
 Rouleau en nylon grand à visser
 Maxi-Walze aus Nylon zum Anschrauben
 Maxi-rodillo de nylon para fijar
 Прикрепляемый максироллик из нейлона



CODE	ART.	Size	Box info	
			Pcs per pack	Kg
11305701 001	253-40	Ø 40	3	3,0

Finishing: Zincato / Galvanized

Categoria commerciale: 1L

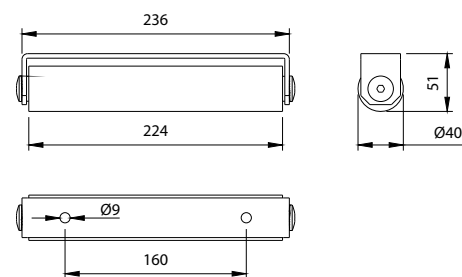

255

Piastra guida cancello a doppia regolazione
 Guiding plate for gates with double adjustment
 Platine guide-portail à double réglage
 Torführungsbügel mit Doppelverstellung
 Placa de guía de la puerta de doble regulación
 Пластина направляющая ворот с двойным регулированием



CODE	ART.	Size	C	D	E	H	L	M	R	S	Box info	
											Pcs per pack	Kg
11306005 001	255-220	Ø30	40	Ø30	135-175	74	220	38	35-62	3	10	22,70
11306010 001	255-350	Ø40	58	Ø39	176-222	98	350	47	62-85	4	5	27,90

Finishing: Zincato / Galvanized

Categoria commerciale: 1L

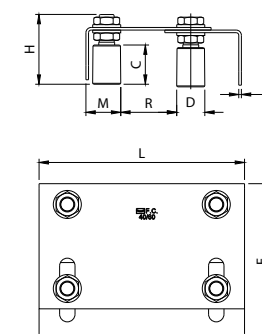

255i

Piastra guida cancello a doppia regolazione
 Guiding plate for gates with double adjustment
 Platine guide-portail à double réglage
 Torführungsbügel mit Doppelverstellung
 Placa de guía de la puerta de doble regulación
 Пластина направляющая ворот с двойным регулированием



CODE	ART.	Size	C	D	E	H	L	M	R	S	Box info	
											Pcs per pack	Kg
11306105	225i-220	Ø30	40	Ø30	135-175	74	220	38	35-62	2,5	1	2,3

Finishing: Inox / Stainless steel

Categoria commerciale: 2L

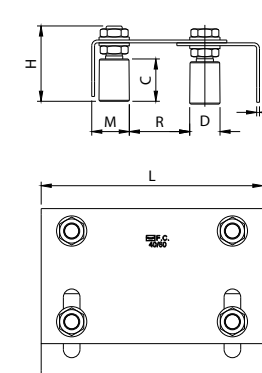



256

Piastra guida cancello regolabile con ala lunga a fissare

Adjustable guiding plate for gates with long wing to be screwed

Platine guide-portail réglable avec aile longue à visser

Verstellbarer Torführungsbügel mit langem Flügel zum Anschrauben

Placa de guía de la puerta regulable con ala larga para fijar

Пластина регулируемая направляющая ворот с длинной прикреплёмой полкой

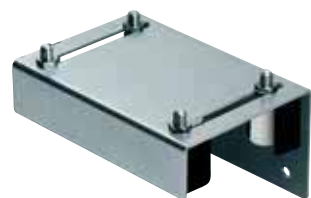

CODE	ART.	Size	A	B	C	D	G	H	I	L	M	R	Box info	
													Pcs per pack	Kg
11305905 001	256-220	Ø30	70	175	40	Ø30	85	110	165	220	45	0-80	4	11,60
11305910 001	256-300	Ø40	80	230	58	Ø40	150	150	230	300	52	0-120	2	9,10

Finishing: Zincato / Galvanized

Categoria commerciale: 1L

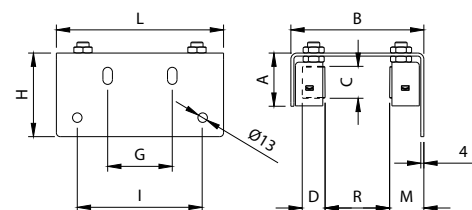

258

Piastra guida cancello interna regolabile a fissare

Adjustable internal guiding plate for gates to be screwed

Platine guide-portail intérieur réglable à visser

Verstellbarer Innenführungsbügel für Tore zum Anschrauben

Placa de guía de la puerta interior regulable para fijar

Внутренняя прикреплёмая пластина регулируемая направляющая ворот

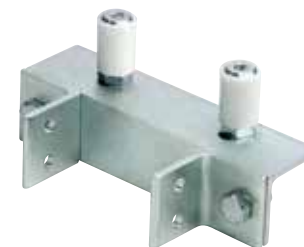

CODE	ART.	E	R	Box info	
				Pcs per pack	Kg
11306405 001	258-30	80-120	30-45	6	14,4

Finishing: Zincato / Galvanized

Categoria commerciale: 1L

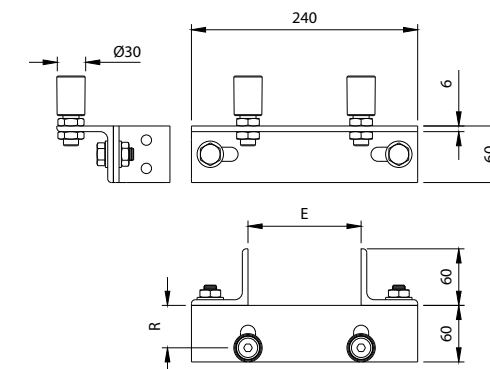

Mounting instructions art. 256

256-220
min 13mm
max 34mm

256-300
min 13mm
max 41mm

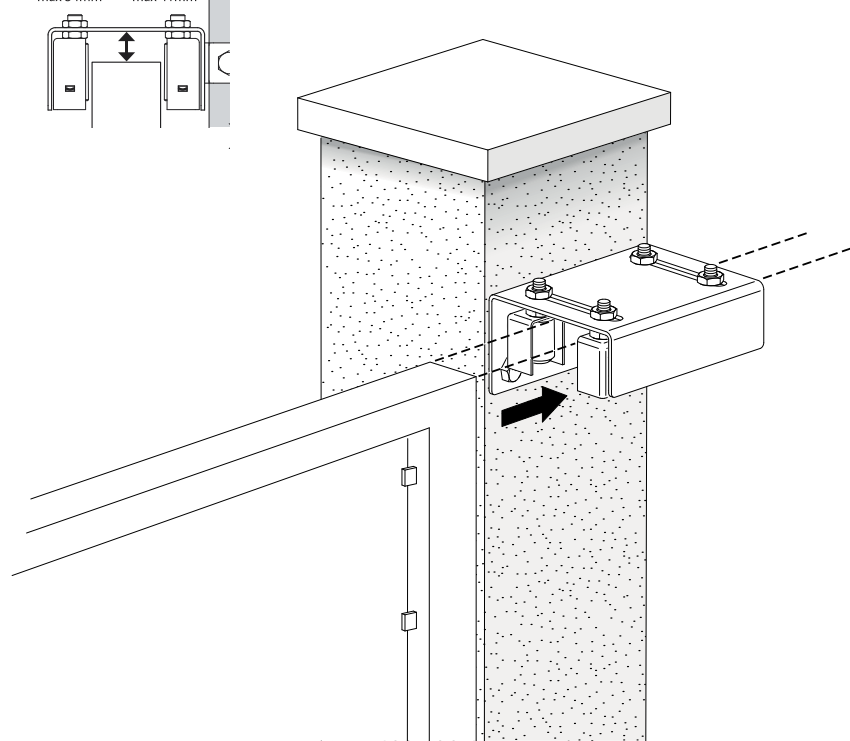

Mounting instructions art. 258

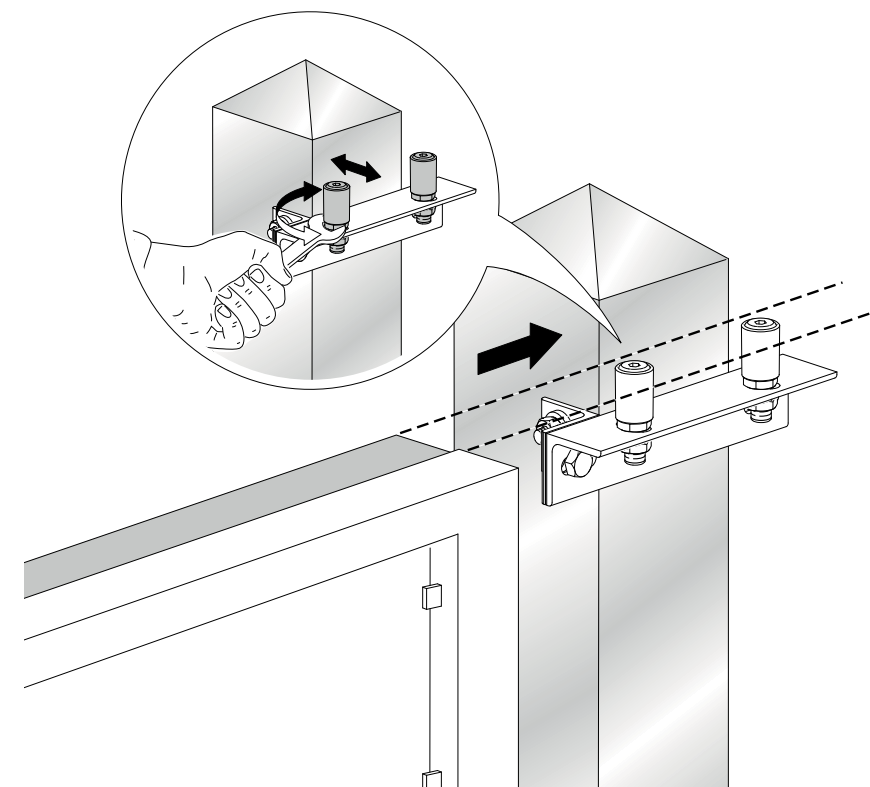



CREMAGLIERE

RACKS

05

260

Cremagliera quadra
Square rack
Crémaillère carrée
Viereckige Zahnstange
Cremallera cuadrada
Зубчатая рейка квадратная



CODE	ART.	Size	A	L	Box info	
					Pcs per pack	Kg
11400505 001	260-22x22	L=1000	22	1000	1	3,10
11400510 001	260-22x22	L=2000	22	2000	1	6,20
11400515 001	260-30x30	L=1000	30	1000	1	6,00

Finishing: Zincato / Galvanized
260-30x30: Modulo 6 / Module 6

Categoria commerciale: 1F

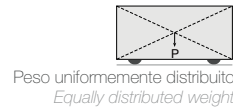
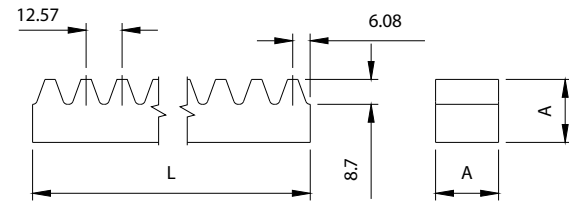

262

Cremagliera Rettangolare
30x8 - 30x12 con fori
Rectangular rack 30x8-30x12 with holes
Crémaillère rectangulaire 30x8-30x12 avec trous
Rechteckige Zahnstange 30x8-30x12 mit Bohrungen
Cremallera Rectangular 30x8 - 30x12 con agujeros
Зубчатая рейка прямоугольная 30x8 - 30x12 с отверстиями

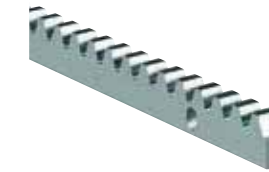

CODE	ART.	Size	L	Box info	
				Pcs per pack	Kg
11401205 001	262-30x8	L=1000	1000	1	1,60
11401005 001	262-30x12	L=1000	1000	1	2,40
11401010 001	262-30x12	L=2000	2000	1	4,90

Finishing: Zincato / Galvanized

Categoria commerciale: 1F

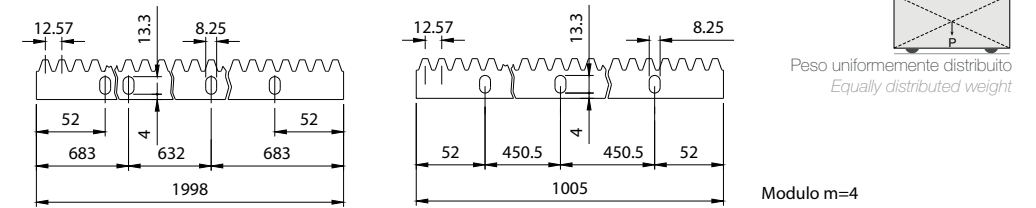

260i

Cremagliera quadra
Square rack
Crémaillère carrée
Viereckige Zahnstange
Cremallera cuadrada
Зубчатая рейка квадратная



CODE	ART.	Size	Box info	
			Pcs per pack	Kg
11400610	260i-22x22	L=2000	1	6,50

Finishing: Inox / Stainless steel

Categoria commerciale: 2F

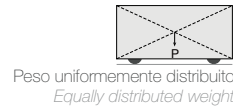
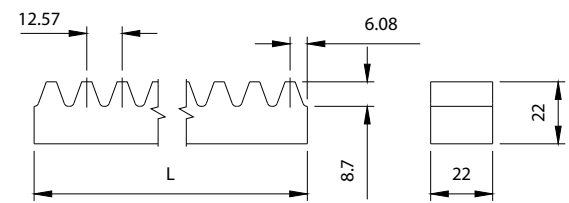

Modulo m=4

262i

Cremagliera Rettangolare 30x12
con fori
Rectangular rack 30x12 with holes
Crémaillère rectangulaire 30x12 avec trous
Rechteckige Zahnstange 30x12 mit Bohrungen
Cremallera rectangular 30x12 con agujeros
Зубчатая рейка прямоугольная 30x12 с отверстиями

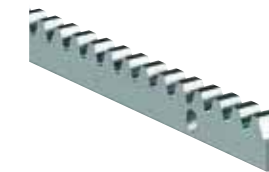

CODE	ART.	Size	L	Box info	
				Pcs per pack	Kg
11401105	262i-30x12	L=1000	1000	1	2,40

Finishing: Inox / Stainless steel

Categoria commerciale: 2F

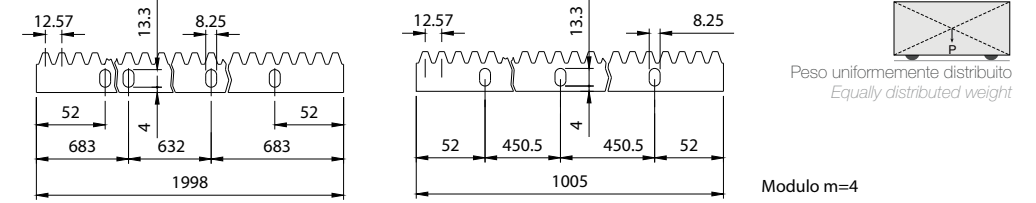

261

Cremagliera in nylon
e corpo in acciaio
Nylon-rack with steel body
Crémaillère en nylon avec corps en acier
Nylon-Zahnstange mit Stahlkörper
Cremallera de nylon y cuerpo de acero
Зубчатая рейка из нейлона и корпус из нержавеющей стали



CODE	ART.	Size	Box info	
			Pcs per pack	Kg
11400102	261-26x20	L=1000	1	1,10

Categoria commerciale: 1F

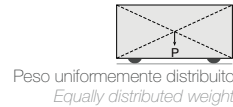
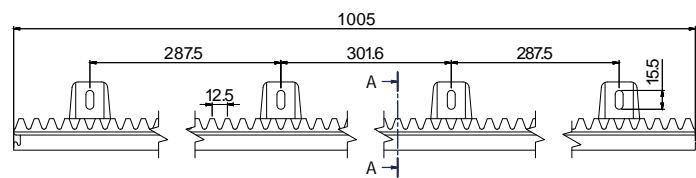

A-A (1:2)

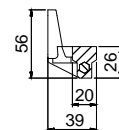

263

Distanziale per cremagliera rettangolare
Fixing unit for rectangular rack
Attache-entretoise pour crémaillère rectangulaire
Distanzstück für rechteckige Zahnstange
Distanciador para cremallera rectangular
Распорная деталь для прямоугольной зубчатой рейки



CODE	ART.	Box info	
		Pcs per pack	Kg
11401710 001	263	30	2,00

Finishing: Zincato / Galvanized

Categoria commerciale: 1F

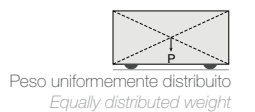
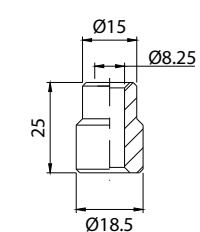



264

Attacco a saldare
per cremagliera rettangolare
Support for rectangular rack to be welded
Attache entretoise pour crémaillère rectangulaire
Distanzstück für rechteckige Zahnstange zum Schweißen
Fijación para soldar para cremallera rectangular
Привариваемое соединение для прямоугольной зубчатой рейки



CODE	ART.	Box info	
		Pcs per pack	Kg
11401505 001	264	30	1,50

Finishing: Zincato / Galvanized

Categoria commerciale: 1F

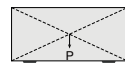
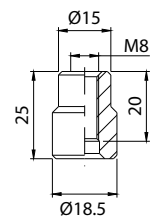

Peso uniformemente distribuito
Equally distributed weight

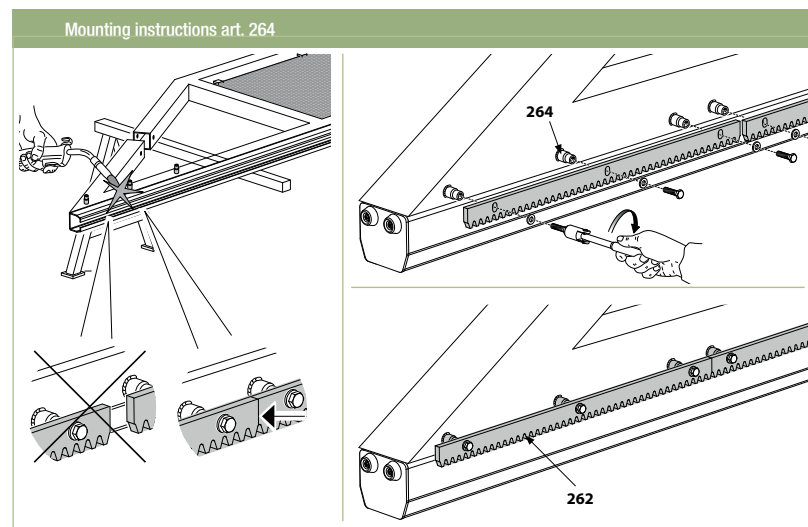

265

Cremagliera anti intrusione
Anti theft rack
Crémaillère antivol
Zackenleiste
Cremallera contra intrusión
Зубчатая рейка против проникновения



CODE	ART.	Size	Box info	
			Pcs per pack	Kg
11402001	265	2000	10	8,4
11402005	265	3000	10	13,4

Finishing: Zincato / Galvanized

Categoria commerciale: 1F

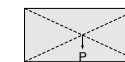
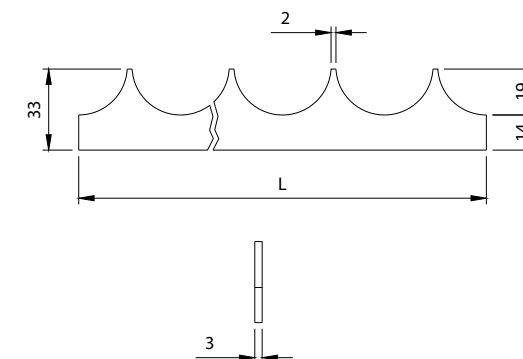

Peso uniformemente distribuito
Equally distributed weight

264i

Attacco a saldare
per cremagliera rettangolare
Support for rectangular rack to be welded
Attache entretoise pour crémaillère rectangulaire
Distanzstück für rechteckige Zahnstange zum Schweißen
Fijación para soldar para cremallera rectangular
Привариваемое соединение для прямоугольной зубчатой рейки



CODE	ART.	Box info	
		Pcs per pack	Kg
11401905	264i	20	1,0

Finishing: Inox / Stainless steel

Categoria commerciale: 2F

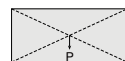
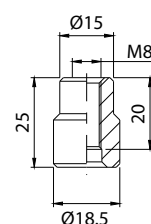

Peso uniformemente distribuito
Equally distributed weight

266

Attacco in zama
per cremagliera rettangolare
Alloy support for rectangular rack
Attache entretoise en zamac pour crémaillère rectangulaire
Zamak-Distanzstück für rechteckige Zahnstange
Fijación de zamak para cremallera rectangular
Соединение из сплава замка для прямоугольной зубчатой рейки



CODE	ART.	Box info	
		Pcs per pack	Kg
11402505 001	266	30	2,10

Finishing: Zincato / Galvanized

Categoria commerciale: 1F

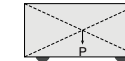
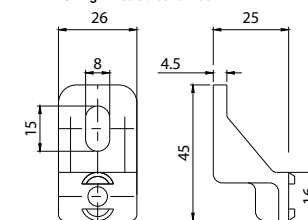

Peso uniformemente distribuito
Equally distributed weight

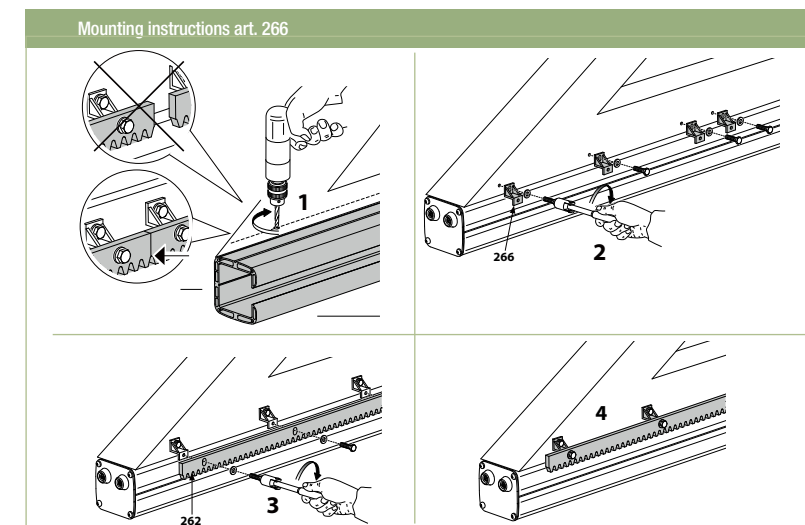

BINARI
TRACKS

006



287

Binario a cementare "Pendolino"
Track to be cemented "Pendolino"
Rail à sceller "Pendolino"
Bodenauflagschiene zum Einbetonieren "Pendolino"
Caril para cementar "Pendolino"
Рельсы цементируемые "Pendolino"

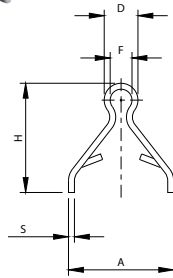

CODE	ART.	Size	A	D	F	H	S	Box info	
								Pcs per pack	Kg
10204001 001	287P-015-Sp3	L=3000	44	Ø15	Ø9	48	3	10	75,00
10204011 001	287P-015-Sp3	L=3000	44	Ø15	Ø9	48	3	54	405,00
10204002 001	287P-015-Sp3	L=6000	44	Ø15	Ø9	48	3	10	150,00
10204012 001	287P-015-Sp3	L=6000	44	Ø15	Ø9	48	3	54	810,00
10204018 001	287-Ø17-Sp3	L=6000	53	Ø17	Ø11	55	3	10	184,00
10204020 001	287-Ø17-Sp3	L=6000	53	Ø17	Ø11	55	3	54	994,00
10204013 001	287G-Ø19-Sp3	L=3000	58	Ø19	Ø13	55	3	10	90,00
10204007 001	287G-Ø19-Sp3	L=3000	58	Ø19	Ø13	55	3	54	490,00
10204014 001	287G-Ø19-Sp3	L=6000	58	Ø19	Ø13	55	3	10	180,00
10204008 001	287G-Ø19-Sp3	L=6000	58	Ø19	Ø13	55	3	54	975,00
10204015 001	287G-Ø19-Sp4	L=3000	58	Ø19,5	Ø13	55,5	4	10	110,00
10204009 001	287G-Ø19-Sp4	L=3000	58	Ø19,5	Ø13	55,5	4	54	600,00
10204016 001	287G-Ø19-Sp4	L=6000	58	Ø19,5	Ø13	55,5	4	10	220,00
10204010 001	287G-Ø19-Sp4	L=6000	58	Ø19,5	Ø13	55,5	4	54	1188,00

Finishing: Zincato / Galvanized

Categoria commerciale: 11

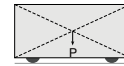

Peso uniformemente distribuito
Equally distributed weight

Mounting instructions art. 287

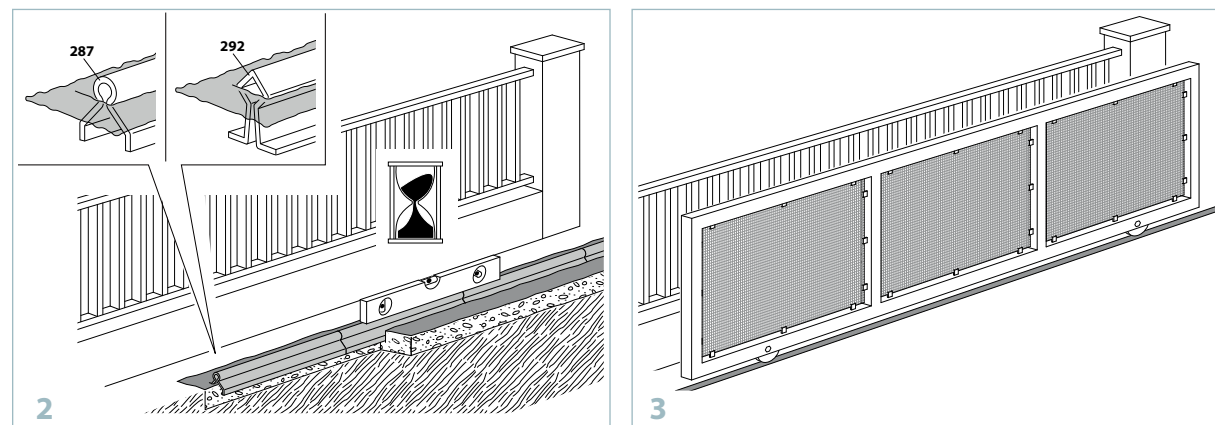
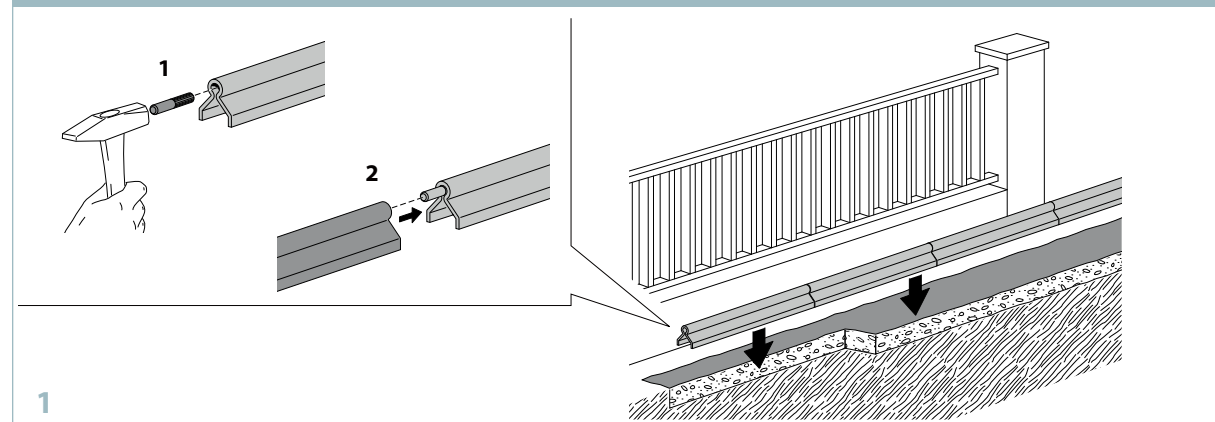

287 FP

Kit per 287G sp. 4mm filo pavimento
Kit for art. 287G at floor level 4mm tick
Kit pour art. 287G au niveau du sol épaisseur 4mm
Satz für art. 287G auf dem Fußbodenniveau 4mm stark
Kit para 287G esp. 4 mm a ras del suelo
Комплект для 287G толщ. 4 мм на уровне пола



CODE	ART.	Size	Box info	
			Pcs per pack	Kg
10204201 001	287FP-G	L=3000	1	11,30
10204202 001	287FP-G	L=6000	1	22,50

Finishing: Zincato / Galvanized

Categoria commerciale: 11

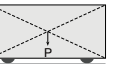
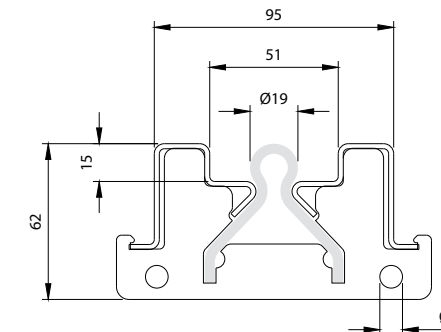

Peso uniformemente distribuito
Equally distributed weight

Mounting instructions art. 287 FP

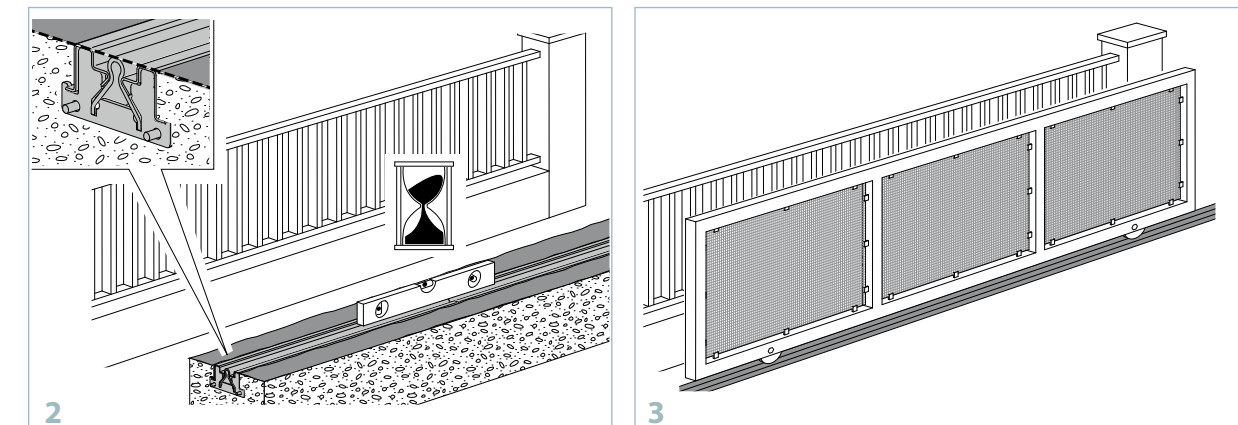
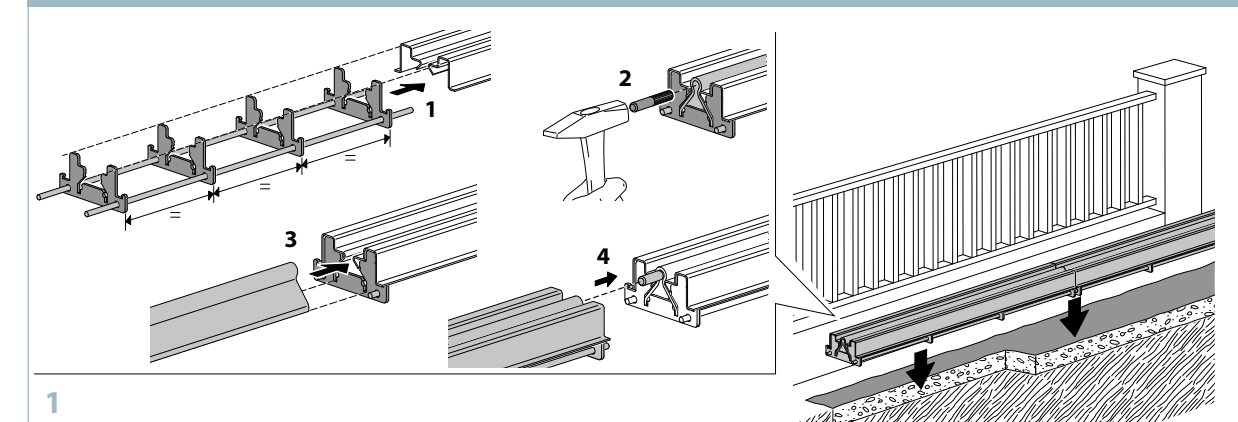

287i

Binario a cementare "Pendolino"
Track to be cemented "Pendolino"
Rail à sceller "Pendolino"
Bodenlaufschiene zum Einbetonieren "Pendolino"
Carril para cementar "Pendolino"
Рельсы цементируемые "Pendolino"



CODE	ART.	L	A	D	F	H	S	Box info	
								Pcs per pack	Kg
10204113	287i-G-Ø19-Sp2	L=3000	65	Ø19	Ø15	52	2	1	6,0
10204114	287i-G-Ø19-Sp2	L=6000	65	Ø19	Ø15	52	2	1	12,00

Finishing: Inox / Stainless steel

Categoria commerciale: 2I

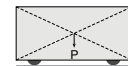
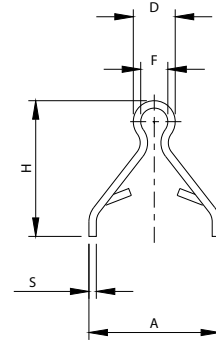

Peso uniformemente distribuito
Equally distributed weight

290

Spina di collegamento per binario
Art. 289 - Ø15
Connection pin for track Art. 289 - Ø15
Jonction pour rail Art. 289 - Ø15
Verbindungsstift zum Laufschiene Art. 289 - Ø15
Pasador de conexión para carril Art.289 - Ø15
Соединительный штырь для рельс арт.289 - Ø15



CODE	ART.	Size	A	F	L	Box info	
						Pcs per pack	Kg
10601501 001	290	90-Ø9	Ø9,5	Ø9	90	10	0,50

Finishing: Zincato / Galvanized

Categoria commerciale: 1I

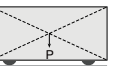
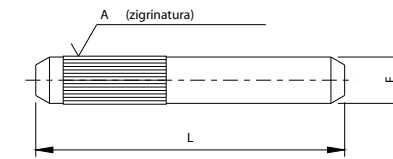

Peso uniformemente distribuito
Equally distributed weight

289

Binario a fissare "Rapido"
Track to be bolted "Rapido"
Rail à visser "Rapido"
Laufschiene zum Anschrauben "Rapido"
Carril para fijar "Rapido"
Рельсы прикрепляемые "Rapido"



CODE	ART.	D	F	L	H	S	Box info	
							Pcs per pack	Kg
10201501 001	289P-Ø15-Sp3	Ø15	Ø9,5	3000	13	3	25	116,00
10201502 001	289P-Ø15-Sp3	Ø15	Ø9,5	6000	13	3	25	232,00
10201505 001	289G-Ø19-Sp3	Ø19	Ø12	3000	16	3	25	123,00
10201510 001	289G-Ø19-Sp3	Ø19	Ø12	6000	16	3	25	246,00

Finishing: Zincato / Galvanized

Categoria commerciale: 1I

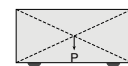
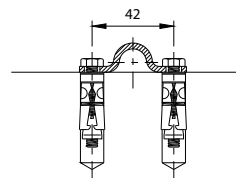
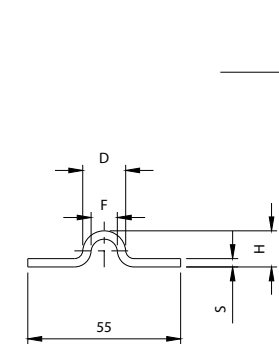

Peso uniformemente distribuito
Equally distributed weight

291

Spina di collegamento per binario
Art. 289 - Ø19
Connection pin for track Art. 289 - Ø19
Jonction pour rail Art. 289 - Ø19
Verbindungsstift zum Laufschiene Art. 289 - Ø19
Pasador de conexión para carril Art.289 - Ø19
Соединительный штырь для рельс арт.289 - Ø19



CODE	ART.	Size	F	L	Box info	
					Pcs per pack	Kg
10602005 001	291	80-Ø12	Ø12	80	10	0,80

Finishing: Zincato / Galvanized

Categoria commerciale: 1I

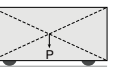
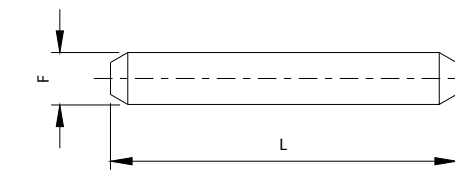

Peso uniformemente distribuito
Equally distributed weight

289i G

Binario a fissare "Rapido"
Track to be bolted "Rapido"
Rail à visser "Rapido"
Laufschiene zum Anschrauben "Rapido"
Carril para fijar "Rapido"
Рельсы прикрепляемые "Rapido"



CODE	ART.	D	F	L	H	S	Box info	
							Pcs per pack	Kg
10201605	289i-G-Ø19-Sp2	Ø19	Ø12	3000	15	2	1	3,30
10201610	289i-G-Ø19-Sp2	Ø19	Ø12	6000	15	2	1	6,60

Finishing: Inox / Stainless steel

Categoria commerciale: 2I

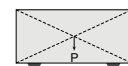
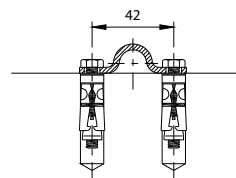
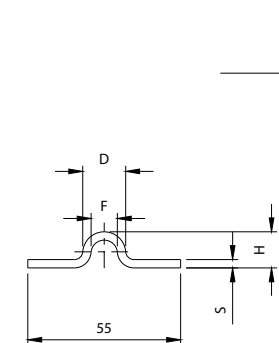

Peso uniformemente distribuito
Equally distributed weight

291i

Spina di collegamento per binario
Art. 289i - Ø19
Connection pin for track Art. 289i - Ø19
Jonction pour rail Art. 289i - Ø19
Verbindungsstift zum Laufschiene Art. 289i - Ø19
Pasador de conexión para carril Art.289i - Ø19
Соединительный штырь для рельс арт.289i - Ø19

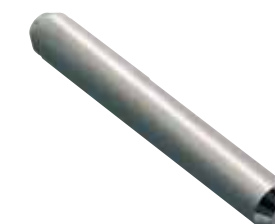

CODE	ART.	Size	F	L	Box info	
					Pcs per pack	Kg
10602105	291i	80-Ø12,5	Ø12,5	80	1	0,10

Finishing: Inox / Stainless steel

Categoria commerciale: 2I

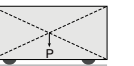
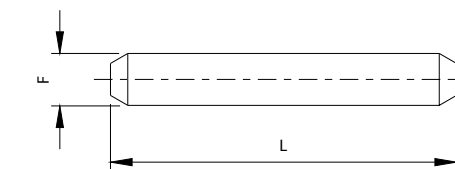

Peso uniformemente distribuito
Equally distributed weight

292

Binario a cementare "Espresso"
Track to be cemented "Espresso"
Rail à sceller "Espresso"
Laufschiene zum Einbetonieren "Espresso"
Pasador para cementar "Espresso"
Рельсы цементируемые "Espresso"



CODE	ART.	Size	L	S	Box info	
					Pcs per pack	Kg
10201905 001	292	L=3000	3000	3	26	295,00
10201910 001	292	L=6000	6000	3	26	590,00

Finishing: Zincato / Galvanized

Categoria commerciale: 11

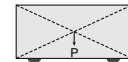
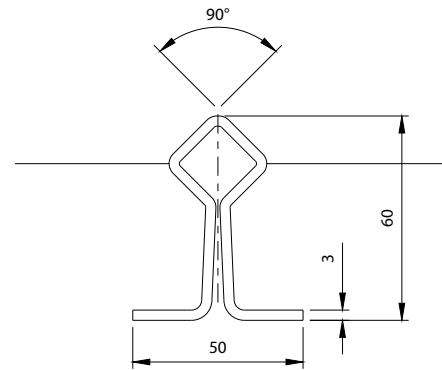

Peso uniformemente distribuito
Equally distributed weight

294

Spina di collegamento per binario Art. 292
Connection pin for track Art. 292
Jonction pour rail Art. 292
Verbindungsstift zum Art. 292
Pasador de conexión para carril Art.292
Соединительный штырь для рельс арт.292



CODE	ART.	Size	A	F	L	Box info	
						Pcs per pack	Kg
10602205 001	294	90-Ø17	Ø17,5	Ø17	90	10	1,70

Finishing: Zincato / Galvanized

Categoria commerciale: 11

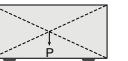
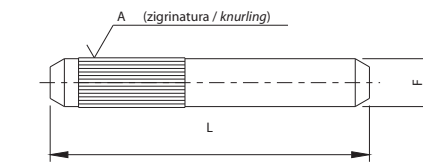

Peso uniformemente distribuito
Equally distributed weight

293

Binario a fissare "Diretto"
Track to be bolted "Diretto"
Rail à visser "Diretto"
Laufschiene zum Anschrauben "Diretto"
Carril para fijar "Diretto"
Рельсы прикрепляемые "Diretto"

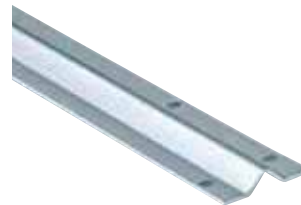

CODE	ART.	Size	L	H	S	Box info	
						Pcs per pack	Kg
10201705 001	293	L=3000	3000	14	3	25	113,00
10201710 001	293	L=6000	6000	14	3	25	225,00

Finishing: Zincato / Galvanized

Categoria commerciale: 11

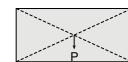
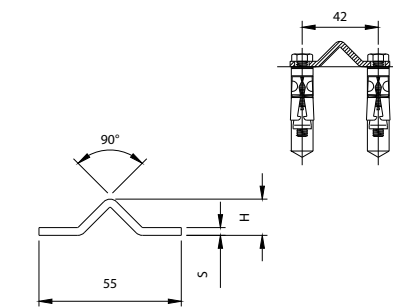

Peso uniformemente distribuito
Equally distributed weight

295

Spina di collegamento per binario Art. 293 - 287 Ø15
Connection pin for track Art. 293 - 287 Ø15
Jonction pour rail Art. 293 - 287 Ø15
Verbindungsstift zum Art. 293 - 287 Ø15
Pasador de conexión para carril Art.293 - 287 Ø15
Соединительный штырь для рельс арт.293 - 287 Ø15



CODE	ART.	Size	A	F	L	Box info	
						Pcs per pack	Kg
10602405 001	295	90-Ø9,5	Ø10	Ø9,5	90	10	0,50

Finishing: Zincato / Galvanized

Categoria commerciale: 11

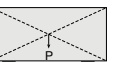
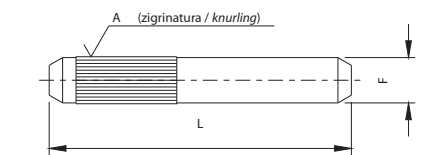

Peso uniformemente distribuito
Equally distributed weight

293i

Binario a fissare "Diretto"
Track to be bolted "Diretto"
Rail à visser "Diretto"
Laufschiene zum Anschrauben "Diretto"
Carril para fijar "Diretto"
Рельсы прикрепляемые "Diretto"



CODE	ART.	Size	L	H	S	Box info	
						Pcs per pack	Kg
10201805	293i	L=3000	3000	13	2	1	3,00
10201810	293i	L=6000	6000	13	2	1	6,00

Finishing: Inox / Stainless steel

Categoria commerciale: 21

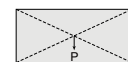
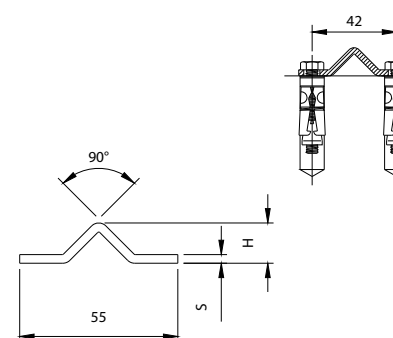

Peso uniformemente distribuito
Equally distributed weight

295i

Spina di collegamento per binario Art.293i
Connection pin for track Art.293i
Jonction pour rail Art.293i
Verbindungsstift zum Art.293i
Pasador de conexión para carril Art.293i
Соединительный штырь для рельс арт.293i



CODE	ART.	Size	A	F	L	Box info	
						Pcs per pack	Kg
10602305	295i	90-Ø8,5	Ø10	Ø8,5	90	1	0,05

Finishing: Inox / Stainless steel

Categoria commerciale: 21

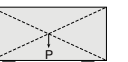
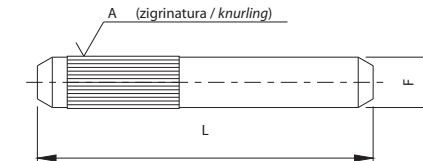

Peso uniformemente distribuito
Equally distributed weight

297

Spina di collegamento per binario Art. 287G - sp 3-4 mm
 Connection pin for Art.287G 3-4 mm tick
 Jonction pour rail Art.287G ép. 3-4 mm
 Verbindungsstift zum Artikel 287G 3-4 mm Stärke
 Pasador de conexión para carril Art.287G - esp.3-4 mm
 Соединительный штырь для рельс арт.287G - толщ.3-4 мм



CODE	ART.	Size	A	F	L	Box info	
						Pcs per pack	Kg
10601605 001	297	90-Ø12,5	Ø13,0	Ø12,5	90	10	0,90

Finishing: Zincato / Galvanized

Categoria commerciale: 11

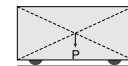
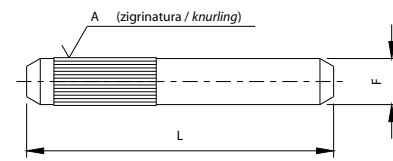

Peso uniformemente distribuito
 Equally distributed weight

297 G

Spina di collegamento per binario Art. 287 ø17
 Connection pin for Art.287 ø17
 Jonction pour rail Art.287 ø17
 Verbindungsstift zum Artikel 287 ø17
 Pasador de conexión para carril Art.287 ø17 mm
 Соединительный штырь для рельс арт.287 ø17



CODE	ART.	Size	A	F	L	Box info	
						Pcs per pack	Kg
10601610 001	297G	90-Ø11,0	Ø11,5	Ø11,0	90	10	0,70

Finishing: Zincato / Galvanized

Categoria commerciale: 11

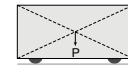
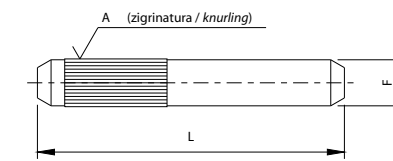

Peso uniformemente distribuito
 Equally distributed weight

297i

Spina di collegamento per binario Art. 287i-G
 Connection pin for track 287i-G
 Jonction pour rail Art.287i-G
 Verbindungsstift zum Laufschiene Art. 287i-G
 Pasador de conexión para carril Art.287i-G
 Соединительный штырь для рельс арт.287i-G



CODE	ART.	Size	A	F	L	Box info	
						Pcs per pack	Kg
10601705	297i	90-Ø14,0	Ø14,5	Ø14,0	90	1	0,11

Finishing: Inox / Stainless steel

Categoria commerciale: 21

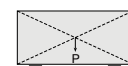
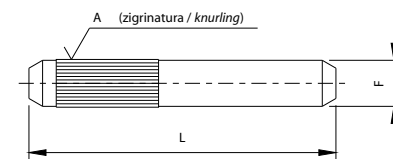

Peso uniformemente distribuito
 Equally distributed weight



Intuitivo, ricco e completo.
Comunello.com,
 nuovissimo portale di
 facile navigazione

Intuitive, rich and complete.
Comunello.com,
 brand new portal easy navigation



Ordina e descrive in maniera esauriente, chiara, fresca ed accattivante le attività del Gruppo fino al più piccolo elemento.

Order and describes in an extensive, clear, fresh and engaging activities Group to the smallest element.



RUOTE
WHEELS

07

300W

Ruota gola V
Wheel with V groove
Galet avec gorge V
Schiebetorrolle mit V-Rille
Rueda canal V
Колесо с пазом V

1 CUSCINETTO
1 BEARING



CODE	ART.	B	C	D	L	Perno Wheel Pin	Portata ruota-Kg Capacity wheel-Kg	Box info	
								Pcs per pack	Kg
11501001 001	300V-40	4	16	Ø 40	12	M8 x 30	50	50	5,10
11501005 001	300V-50	4	16	Ø 50	12	M8 x 30	70	30	4,90
11501010 001	300V-60	7	24	Ø 60	16,5	M10 x 45	100	12	3,70
11501015 001	300V-70	7	34	Ø 68	20	M14 x 70	190	12	6,50
11501020 001	300V-80	7	34	Ø 78	20	M14 x 70	200	10	7,00
11501030 001	300V-90	7,5	34	Ø 88	21	M14 x 70	210	8	7,40
11501040 001	300V-100	7,5	34	Ø 98	21	M14 x 70	220	8	9,30
11501050 001	300V-120	7,5	34	Ø 117	21	M14 x 70	240	6	10,0
11501060 001	300V-140	9	44	Ø 137	25	M16 x 70	270	2	4,90
11501070 001	300V-160	9	44	Ø 157	25	M16 x 70	290	2	6,60
11501080 001	300V-200	9	44	Ø 197	25	M16 x 70	330	2	11,20

Finishing: Zincato / Galvanized

Categoria commerciale: 1M

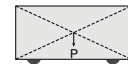
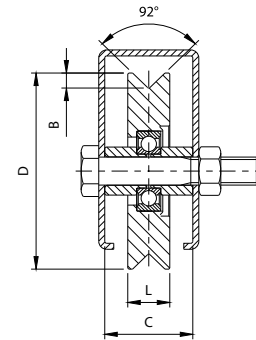

Peso uniformemente distribuito
Equally distributed weight

300U

Ruota gola U
Wheel with U groove
Galet avec gorge U
Schiebetorrolle mit U-Rille
Rueda canal U
Колесо с пазом U

1 CUSCINETTO
1 BEARING



CODE	ART.	A	B	C	D	L	Perno Wheel Pin	Portata ruota-Kg Capacity wheel-Kg	Box info	
									Pcs per pack	Kg
11500501 001	300U-40	6	4	16	Ø 40	12	M8 x 30	50	50	5,10
11500505 001	300U-50	6	4	16	Ø 50	12	M8 x 30	70	30	4,90
11500510 001	300U-60	8	7	24	Ø 60	16,5	M10 x 45	100	12	3,70
11500515 001	300U-70	8	8	34	Ø 68	20	M14 x 70	190	12	6,50
11500520 001	300U-80	8	8	34	Ø 78	20	M14 x 70	200	10	7,00
11500530 001	300U-90	8	8	34	Ø 88	21	M14 x 70	210	8	7,40
11500540 001	300U-100	8	8	34	Ø 98	21	M14 x 70	220	8	9,30
11500550 001	300U-120	8	8	34	Ø 117	21	M14 x 70	240	6	10,0
11500560 001	300U-140	16	10	44	Ø 137	25	M16 x 70	270	2	4,90
11500570 001	300U-160	16	10	44	Ø 157	25	M16 x 70	290	2	6,60
11500580 001	300U-200	16	10	44	Ø 197	25	M16 x 70	330	2	11,20

Finishing: Zincato / Galvanized

Categoria commerciale: 1M

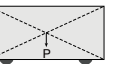
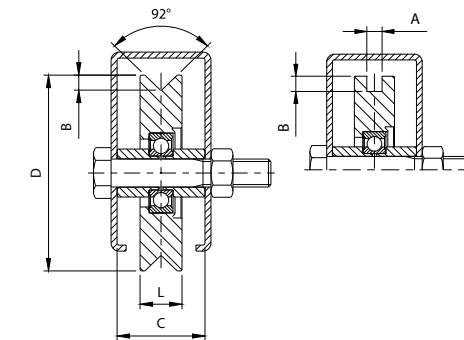

Peso uniformemente distribuito
Equally distributed weight

300i

Ruota gola V
Wheel with V groove
Galet avec gorge V
Schiebetorrolle mit V-Rille
Rueda canal V
Колесо с пазом V

1 CUSCINETTO
1 BEARING



CODE	ART.	B	C	D	L	Perno Wheel Pin	Portata ruota-Kg Capacity wheel-Kg	Box info	
								Pcs per pack	Kg
11501410	300i-V60	7	24	Ø 60	16,5	M10 x 45	100	2	0,70
11501420	300i-V80	7	34	Ø 78	20	M14 x 70	200	2	1,42
11501430	300i-V90	7,5	34	Ø 88	21	M14 x 70	210	2	1,92
11501440	300i-V100	7,5	34	Ø 98	21	M14 x 70	220	2	2,43
11501450	300i-V120	7,5	34	Ø 117	21	M14 x 70	240	2	3,43
11501460	300i-V140	9	44	Ø 137	25	M16 x 70	270	2	5,30
11501470	300i-V160	9	44	Ø 157	25	M16 x 70	370	2	6,90
11501480	300i-V200	9	44	Ø 197	25	M16 x 70	400	2	11,30

Finishing: Inox / Stainless steel

Categoria commerciale: 2M

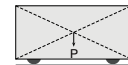
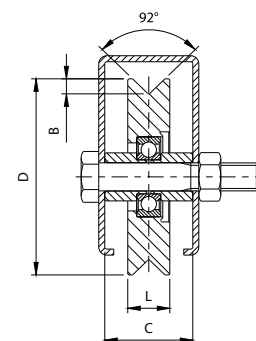

Peso uniformemente distribuito
Equally distributed weight

305i

Ruota gola V
Wheel with V groove
Galet avec gorge V
Schiebetorrolle mit V-Rille
Rueda canal V
Колесо с пазом V

2 CUSCINETTI
2 BEARINGS



CODE	ART.	B	C	D	L	Perno Wheel pin	Portata ruota-Kg Capacity wheel-Kg	Box info	
								Pcs per pack	Kg
11502140	305i-V100	9,5	34	Ø 98	28	M14 x 70	400	2	3,00
11502150	305i-V120	9,5	34	Ø 117	28	M14 x 70	420	2	4,30
11502160	305i-V140	10	44	Ø 137	31	M16 x 70	540	2	6,60
11502170	305i-V160	10	44	Ø 157	33	M16 x 70	770	2	9,50
11502180	305i-V200	10	44	Ø 197	33	M16 x 70	800	2	15,10

Finishing: Inox / Stainless steel

Categoria commerciale: 2M

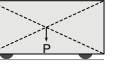
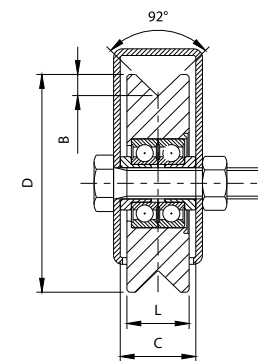

Peso uniformemente distribuito
Equally distributed weight

305 W

Ruota gola V
Wheel with V groove
Galet avec gorge V
Schiebetorrolle mit V-Rille
Rueda canal V
Колесо с пазом V

2 CUSCINETTI
2 BEARINGS



CODE	ART.	B	C	D	L	Perno Wheel Pin	Portata ruota-Kg Capacity wheel-Kg	Box info	
								Pcs per pack	Kg
11502040 001	305V-100	9,5	34	Ø 98	28	M14 x 70	425	8	11,70
11502050 001	305V-120	9,5	34	Ø 117	28	M14 x 70	450	6	12,80
11502060 001	305V-140	10	44	Ø 137	31	M16 x 70	550	2	6,60
11502070 001	305V-160	10	44	Ø 157	33	M16 x 70	575	2	9,20
11502080 001	305V-200	10	44	Ø 197	33	M16 x 70	625	2	14,80

Finishing: Zincato / Galvanized

Categoria commerciale: 1M

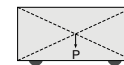
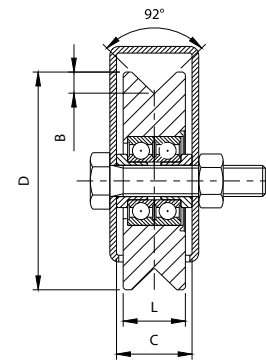

Peso uniformemente distribuito
Equally distributed weight

305 U

Ruota gola U
Wheel with U groove
Galet avec gorge U
Schiebetorrolle mit U-Rille
Rueda canal U
Колесо с пазом U

2 CUSCINETTI
2 BEARINGS



CODE	ART.	A	B	C	D	L	Perno Wheel Pin	Portata ruota-Kg Capacity wheel-Kg	Box info	
									Pcs per pack	Kg
11501540 001	305U-100	16	10	34	Ø 98	28	M14 x 70	425	8	11,70
11501550 001	305U-120	21	10	34	Ø 117	28	M14 x 70	450	6	12,80
11501560 001	305U-140	21	10	44	Ø 137	31	M16 x 70	550	2	6,60
11501570 001	305U-160	21	10	44	Ø 157	33	M16 x 70	575	2	9,20
11501580 001	305U-200	21	10	44	Ø 197	33	M16 x 70	625	2	14,80

Finishing: Zincato / Galvanized

Categoria commerciale: 1M

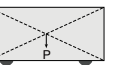
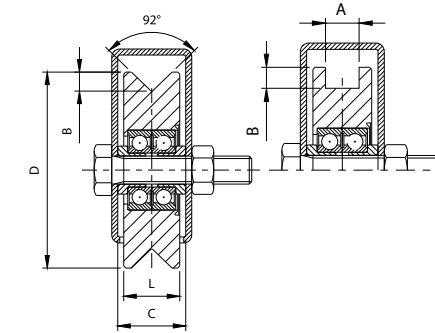

Peso uniformemente distribuito
Equally distributed weight

Mounting instructions art. 305V

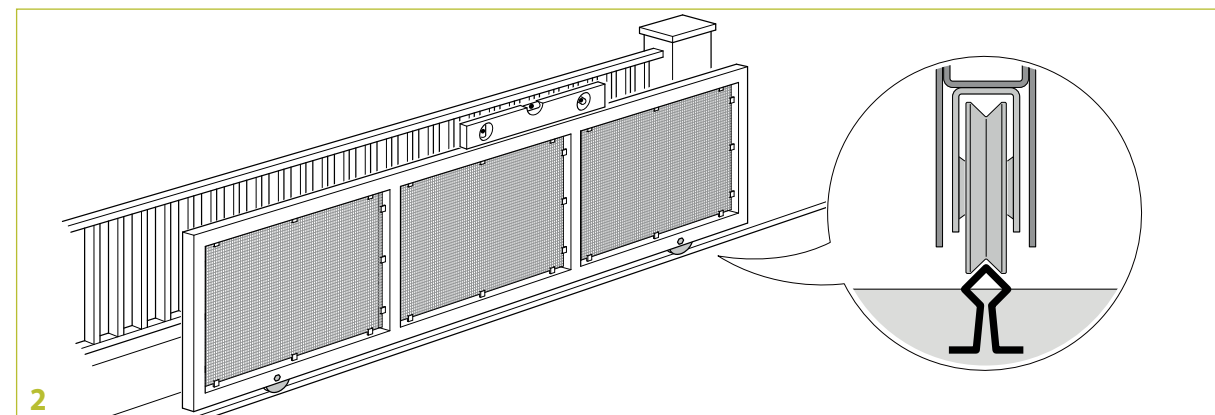
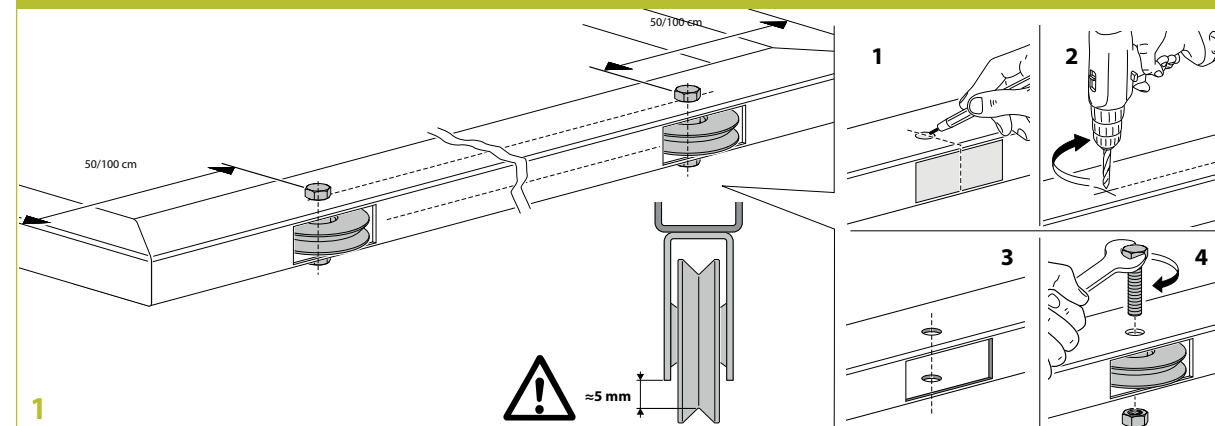

306 W

Ruota gola Y con scarico
Wheel with discharge Y groove
Galet gorge Y avec décharge
Schiebetorrolle mit Y-Rille
Rueda canal Y con descarga
Колесо с пазом Y со стоком

1 CUSCINETTO
1 BEARING



CODE	ART.	B	C	D	L	Perno Wheel Pin	Portata ruota-Kg Capacity wheel-Kg	Box info	
								Pcs per pack	Kg
11502510 001	306Y-60	9	24	Ø 60	16,5	M10 x 45	100	12	3,60
11502520 001	306Y-80	9,5	34	Ø 78	20	M14 x 70	200	10	6,90
11502530 001	306Y-90	10,5	34	Ø 88	21	M14 x 70	210	8	7,10
11502540 001	306Y-100	10,5	34	Ø 98	21	M14 x 70	220	8	8,90
11502550 001	306Y-120	10,5	34	Ø 117	21	M14 x 70	240	6	10,00
11502560 001	306Y-140	12	44	Ø 137	25	M16 x 70	270	2	5,20
11502570 001	306Y-160	12	44	Ø 157	25	M16 x 70	290	2	6,90
11502580 001	306Y-200	12	44	Ø 197	25	M16 x 70	330	2	11,30

Finishing: Zincato / Galvanized

Categoria commerciale: 1M

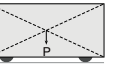
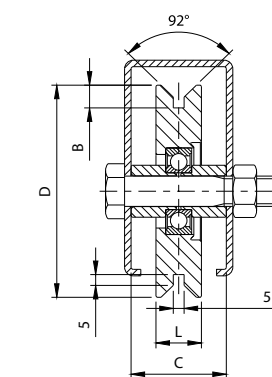

Peso uniformemente distribuito
Equally distributed weight

307 W

Ruota gola Y con scarico
Wheel with discharge Y groove
Galet gorge Y avec décharge
Schiebetorrolle mit Y-Rille
Rueda canal Y con descarga
Колесо с пазом Y со стоком

2 CUSCINETTI
2 BEARINGS



CODE	ART.	B	C	D	L	Perno Wheel Pin	Portata ruota-Kg Capacity wheel-Kg	Box info	
								Pcs per pack	Kg
11503040 001	307Y-100	12,5	34	∅ 98	28	M14 x 70	400	8	11,40
11503050 001	307Y-120	12,5	34	∅ 117	28	M14 x 70	420	6	12,50
11503060 001	307Y-140	12,5	44	∅ 137	31	M16 x 70	540	2	6,60
11503070 001	307Y-160	12,5	44	∅ 157	33	M16 x 70	560	2	9,20
11503080 001	307Y-200	12,5	44	∅ 197	33	M16 x 70	600	2	14,80

Finishing: Zincato / Galvanized

Categoria commerciale: 1M

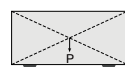
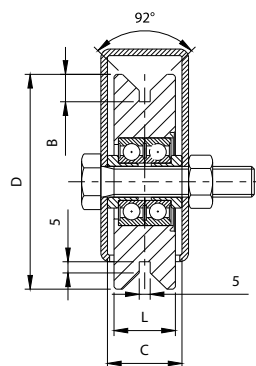

Peso uniformemente distribuito
Equally distributed weight

310 W

Ruota gola semitonda
Wheel with half-rounded groove
Galet avec gorge demi-ronde
Schiebetorrolle mit Rundrille
Rueda canal semirredondo
Колесо с полукруглым пазом

1 CUSCINETTO
1 BEARING



CODE	ART.	B	C	D	L	R	Perno Wheel Pin	Portata ruota-Kg Capacity wheel-Kg	Box info		
									Pcs per pack	Kg	
11504501 001	310-40	4	16	∅ 40	12	4,5	M8 x 30	50	50	5,10	
11504505 001	310-50	4	16	∅ 50	12	4,5	M8 x 30	70	30	4,70	
11504510 001	310-60	4	24	∅ 60	16,5	4,5	M10 x 45	100	12	4,10	
11504515 001	310-70	7,5	34	∅ 68	20	8,5	∅ 15 ∅ 15	M14 x 70	190	12	5,80
11504520 001	310-80	7,5	34	∅ 78	20	8,5	∅ 15 ∅ 15	M14 x 70	200	10	6,40
11504525 001	310-80S	9,5	34	∅ 78	24	10,3	∅ 19 ∅ 19	M14 x 70	200	10	6,60
11504530 001	310-90	7,5	34	∅ 88	21	8,5	∅ 15 ∅ 15	M14 x 70	210	8	6,90
11504535 001	310-90S	9,5	34	∅ 88	24	10,3	∅ 19 ∅ 19	M14 x 70	210	8	7,00
11504540 001	310-100	7,5	34	∅ 98	21	8,5	∅ 15 ∅ 15	M14 x 70	220	8	8,70
11504545 001	310-100S	9,5	34	∅ 98	24	10,3	∅ 19 ∅ 19	M14 x 70	220	8	8,80
11504550 001	310-120	9,5	34	∅ 117	25	10,3	∅ 19 ∅ 19	M14 x 70	240	6	10,40
11504560 001	310-140	9,5	44	∅ 137	25	10,3	∅ 19 ∅ 19	M16 x 70	270	2	5,00
11504570 001	310-160	9,5	44	∅ 157	25	10,3	∅ 19 ∅ 19	M16 x 70	290	2	6,60
11504580 001	310-200	9,5	44	∅ 197	25	10,3	∅ 19 ∅ 19	M16 x 70	330	2	10,70

Finishing: Zincato / Galvanized

Categoria commerciale: 1M

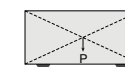
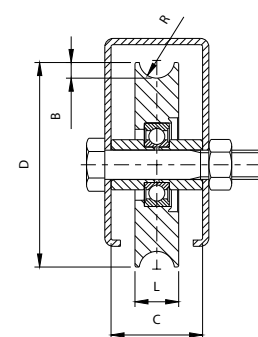

Peso uniformemente distribuito
Equally distributed weight

308 W

Ruota gola Y raccordata
Wheel with Y-rounded groove
Galet avec gorge Y arrondie
Schiebetorrolle mit Y-Rille abgerundeter Führung
Rueda canal Y con racor
Колесо с пазом Y с патрубком

1 CUSCINETTO
1 BEARING



CODE	ART.	A	B	C	D	L	Perno Wheel Pin	Portata ruota-Kg Capacity wheel-Kg	Box info	
									Pcs per pack	Kg
11503505 001	308-50	7	7,5	24	∅ 50	17	M10 x 45	100	12	2,50
11503510 001	308-60	7	7,5	24	∅ 60	16,5	M10 x 45	100	12	3,50
11503520 001	308-80	8	10	34	∅ 78	20	M14 x 70	200	10	5,50

Finishing: Zincato / Galvanized

Categoria commerciale: 1M

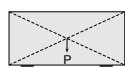
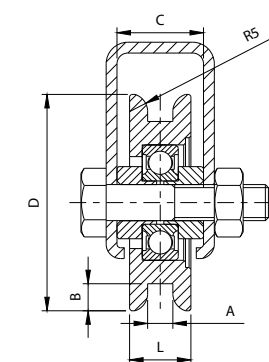

Peso uniformemente distribuito
Equally distributed weight

ART. 310-80

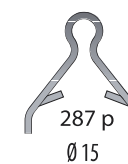
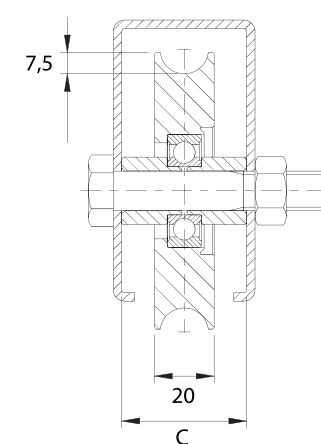

ART. 310-80S

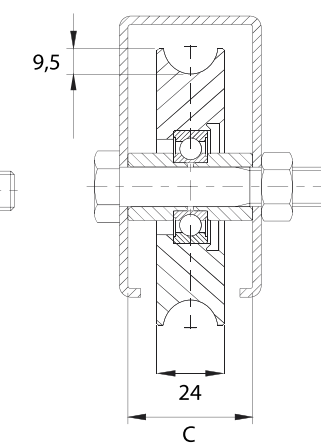

309 W

Ruota gola Y raccordata
Wheel with Y-rounded groove
Galet avec gorge Y arrondie
Schiebetorrolle mit Y-Rille abgerundeter Führung
Rueda canal Y con racor
Колесо с пазом Y с патрубком

2 CUSCINETTI
2 BEARINGS



CODE	ART.	A	B	C	D	L	Perno Wheel Pin	Portata ruota-Kg Capacity wheel-Kg	Box info	
									Pcs per pack	Kg
11504020 001	309-80	8	12,5	34	∅ 78	26	M14 x 70	380	10	8,10
11504040 001	309-100	8	12,5	34	∅ 98	26	M14 x 70	400	8	11,40
11504050 001	309-120	8	12,5	34	∅ 117	26	M14 x 70	420	6	11,50
11504060 001	309-140	9,5	12,5	44	∅ 137	31	M16 x 70	540	2	6,30

Finishing: Zincato / Galvanized

Categoria commerciale: 1M

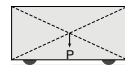
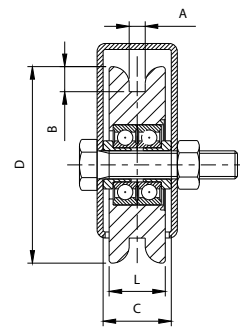

Peso uniformemente distribuito
Equally distributed weight

315 W

Ruota gola semitonda
Wheel with half-rounded groove
Galet avec gorge demi-ronde
Schiebetorrolle mit Rundrille
Rueda canal semirredondo
Колесо с полукруглым пазом

2 CUSCINETTI
2 BEARINGS



CODE	ART.	B	C	D	L	R	Perno Wheel Pin	Portata ruota-Kg Capacity wheel-Kg	Box info	
									Pcs per pack	Kg
11505040 001	315-100	9,5	34	∅ 98	28	10,5	∅ 19 ∅ 19	M14 x 70 425	8	10,80
11505050 001	315-120	9,5	34	∅ 117	28	10,5	∅ 19 ∅ 19	M14 x 70 450	6	11,90
11505060 001	315-140	9,5	44	∅ 137	31	11,5	∅ 19 ∅ 19	M16 x 70 550	2	6,20
11505070 001	315-160	9,5	44	∅ 157	33	11,5	∅ 19 ∅ 19	M16 x 70 575	2	8,90
11505080 001	315-200	9,5	44	∅ 197	33	11,5	∅ 19 ∅ 19	M16 x 70 625	2	14,40

Finishing: Zincato / Galvanized

Categoria commerciale: 1M

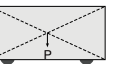
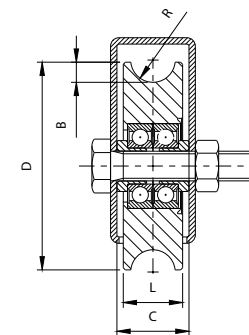

Peso uniformemente distribuito
Equally distributed weight

310i W

Ruota gola semitonda
Wheel with half-rounded groove
Galet avec gorge demi-ronde
Schiebetorrolle mit Rundrille
Rueda canal semirredondo
Колесо с полукруглым пазом

1 CUSCINETTO
1 BEARING



CODE	ART.	B	C	D	L	R	Perno Wheel Pin	Portata ruota-Kg Capacity wheel-Kg	Box info	
									Pcs per pack	Kg
11504810	310i-60	4	24	∅ 60	16,5	4,5	M10 x 45	100	2	0,70
11504825	310i-80S	9,5	34	∅ 78	24	10,3	∅ 19 ∅ 19	M14 x 70 200	2	1,30
11504835	310i-90S	9,5	34	∅ 88	24	10,3	∅ 19 ∅ 19	M14 x 70 210	2	1,70
11504845	310i-100S	9,5	34	∅ 98	24	10,3	∅ 19 ∅ 19	M14 x 70 220	2	2,30
11504850	310i-120	9,5	34	∅ 117	25	10,3	∅ 19 ∅ 19	M14 x 70 240	2	3,50
11504860	310i-140	9,5	44	∅ 137	25	10,3	∅ 19 ∅ 19	M16 x 70 270	2	5,00
11504870	310i-160	9,5	44	∅ 157	25	10,3	∅ 19 ∅ 19	M16 x 70 370	2	6,50
11504880	310i-200	9,5	44	∅ 197	25	10,3	∅ 19 ∅ 19	M16 x 70 400	2	10,50

Finishing: Inox / Stainless steel

Categoria commerciale: 2M

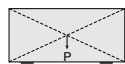
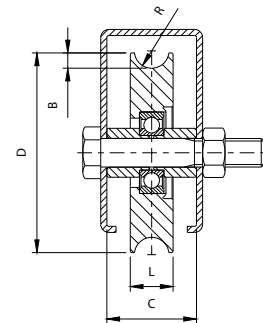

Peso uniformemente distribuito
Equally distributed weight

315i W

Ruota gola semitonda
Wheel with half-rounded groove
Galet avec gorge demi-ronde
Schiebetorrolle mit Rundrille
Rueda canal semirredondo
Колесо с полукруглым пазом

2 CUSCINETTI
2 BEARINGS



CODE	ART.	B	C	D	L	R	Perno Wheel Pin	Portata ruota-Kg Capacity wheel-Kg	Box info	
									Pcs per pack	Kg
11505140	315i-100	9,5	34	∅ 98	28	10,5	∅ 19 ∅ 19	M14 x 70 400	2	2,70
11505150	315i-120	9,5	34	∅ 117	28	10,5	∅ 19 ∅ 19	M14 x 70 420	2	4,00
11505160	315i-140	9,5	44	∅ 137	31	11,5	∅ 19 ∅ 19	M16 x 70 540	2	6,30
11505170	315i-160	9,5	44	∅ 157	33	11,5	∅ 19 ∅ 19	M16 x 70 770	2	9,00
11505180	315i-200	9,5	44	∅ 197	33	11,5	∅ 19 ∅ 19	M16 x 70 800	2	14,50

Finishing: Inox / Stainless steel

Categoria commerciale: 2M

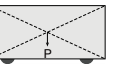
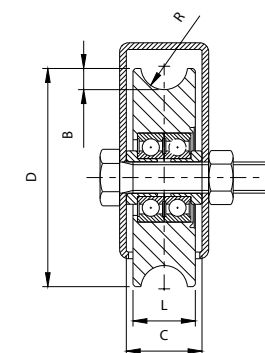

Peso uniformemente distribuito
Equally distributed weight

320 W

Ruota con ingrassatore gola V
Grease gun wheel with V groove
Galet à graisseur gorge V
Schiebetorrolle V-Rille mit Schmiernippel
Rueda con engrasador canal V
Колесо с масляной с пазом V

1 CUSCINETTO
1 BEARING



CODE	ART.	B	C	D	L	Perno Wheel Pin	Portata ruota-Kg Capacity wheel-Kg	Box info	
								Pcs per pack	Kg
11506040 001	320V-100	9	34	Ø 97	26	M18 x 70	380	8	8,70
11506050 001	320V-120	9,5	44	Ø 117	29	M18 x 70	400	6	13,30
11506070 001	320V-160	10	44	Ø 157	31	M20 x 80	710	2	8,50
11506080 001	320V-200	10	44	Ø 197	31	M20 x 80	750	2	13,80
11506090 001	320V-250	12	54	Ø 247	34	M24 x 100	800	2	24,40

Finishing: Zincato / Galvanized

Categoria commerciale: 1M

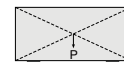
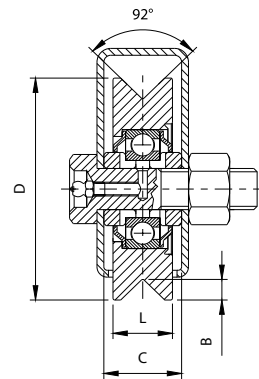

Peso uniformemente distribuito
Equally distributed weight

320 W

Ruota con ingrassatore gola Y
Grease gun wheel with Y groove
Galet à graisseur gorge Y
Schiebetorrolle Y-Rille mit Schmiernippel
Rueda con engrasador canal Y
Колесо с масляной с пазом Y

1 CUSCINETTO
1 BEARING



CODE	ART.	B	C	D	L	Perno Wheel Pin	Portata ruota-Kg Capacity wheel-Kg	Box info	
								Pcs per pack	Kg
11506240 001	320Y-100	10,5	34	Ø 97	26	M18 x 70	380	8	8,70
11506250 001	320Y-120	12,5	44	Ø 117	29	M18 x 70	400	6	13,30
11506270 001	320Y-160	12,5	44	Ø 157	31	M20 x 80	710	2	8,50
11506280 001	320Y-200	12,5	44	Ø 197	31	M20 x 80	750	2	13,80
11506290 001	320Y-250	15	54	Ø 247	34	M24 x 100	800	2	24,40

Finishing: Zincato / Galvanized

Categoria commerciale: 1M

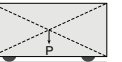
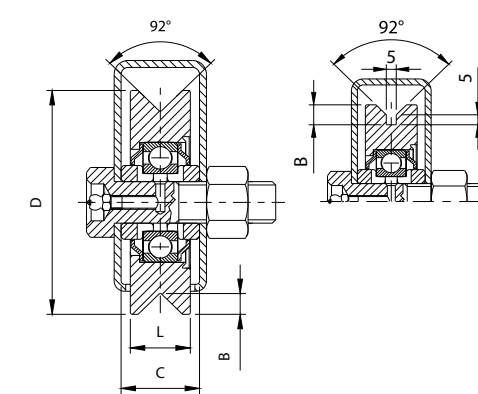

Peso uniformemente distribuito
Equally distributed weight

320 U

Ruota con ingrassatore gola U
Grease gun wheel with U groove
Galet à graisseur gorge U
Schiebetorrolle U-Rille mit Schmiernippel
Rueda con engrasador canal U
Колесо с масляной с пазом U

1 CUSCINETTO
1 BEARING



CODE	ART.	A	B	C	D	L	Perno Wheel Pin	Portata ruota-Kg Capacity wheel-Kg	Box info	
									Pcs per pack	Kg
11505540 001	320U-100	16	10	34	Ø 97	26	M18 x 70	380	8	8,70
11505550 001	320U-120	21	10	44	Ø 117	29	M18 x 70	400	6	13,30
11505570 001	320U-160	21	10	44	Ø 157	31	M20 x 80	710	2	8,50
11505580 001	320U-200	21	10	44	Ø 197	31	M20 x 80	750	2	13,80
11505590 001	320U-250	22	11	54	Ø 247	34	M24 x 100	800	2	24,40

Finishing: Zincato / Galvanized

Categoria commerciale: 1M

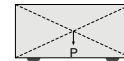
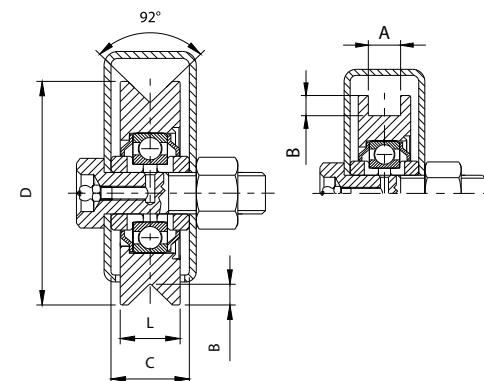

Peso uniformemente distribuito
Equally distributed weight

322 W

Ruota con ingrassatore gola V
Grease gun wheel with V groove
Galet à graisseur gorge V
Schiebetorrolle V-Rille mit Schmiernippel
Rueda con engrasador canal V
Колесо с масляной с пазом V

2 CUSCINETTI
2 BEARINGS



CODE	ART.	B	C	D	L	Perno Wheel Pin	Portata ruota-Kg Capacity wheel-Kg	Box info	
								Pcs per pack	Kg
11507040 001	322V-100	10	44	Ø 98	36	M18 x 70	580	8	15,00
11507041 001	322V-100	10	54	Ø 98	36	M18 x 80	580	8	15,00
11507050 001	322V-120	10	44	Ø 117	36	M18 x 70	600	6	16,10
11507051 001	322V-120	10	54	Ø 117	36	M18 x 80	600	6	16,10
11507070 001	322V-160	10,5	44	Ø 157	38	M18 x 70	960	2	10,40
11507071 001	322V-160	10,5	54	Ø 157	38	M18 x 80	960	2	10,40
11507072 001	322V-160	10,5	74	Ø 157	38	M18 x 100	960	2	10,40
11507080 001	322V-200	10,5	44	Ø 197	38	M18 x 70	1000	2	16,40
11507081 001	322V-200	10,5	54	Ø 197	38	M18 x 80	1000	2	16,40
11507082 001	322V-200	10,5	74	Ø 197	38	M18 x 100	1000	2	16,40
11507090 001	322V-250	14,5	72	Ø 247	48	M24 x 120	1500	2	33,80

Finishing: Zincato / Galvanized

Categoria commerciale: 1M

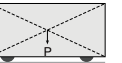
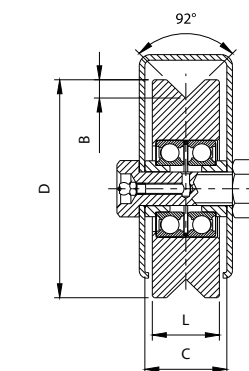

Peso uniformemente distribuito
Equally distributed weight

322 U

Ruota con ingrassatore gola U
Grease gun wheel with U groove
Galet à graisseur gorge U
Schiebetorrolle U-Rille mit Schmiernippel
Rueda con engrasador canal U
Колесо с масляной с пазом U

2 CUSCINETTI
2 BEARINGS



CODE	ART.	A	B	C	D	L	Perno Wheel Pin	Portata ruota-Kg Capacity wheel-Kg	Box info	
									Pcs per pack	Kg
11506540 001	322U-100	16	10	44	∅ 98	36	M18 x 70	580	8	15,00
11506541 001	322U-100	16	10	54	∅ 98	36	M18 x 80	580	8	15,00
11506550 001	322U-120	21	10	44	∅ 117	36	M18 x 70	600	6	16,10
11506551 001	322U-120	21	10	54	∅ 117	36	M18 x 80	600	6	16,10
11506570 001	322U-160	21	10	44	∅ 157	38	M18 x 70	960	2	10,40
11506571 001	322U-160	21	10	54	∅ 157	38	M18 x 80	960	2	10,40
11506572 001	322U-160	21	10	74	∅ 157	38	M18 x 100	960	2	10,40
11506580 001	322U-200	21	10	44	∅ 197	38	M18 x 70	1000	2	16,40
11506581 001	322U-200	21	10	54	∅ 197	38	M18 x 80	1000	2	16,40
11506582 001	322U-200	21	10	74	∅ 197	38	M18 x 100	1000	2	16,40
11506590 001	322U-250	32	13	72	∅ 247	48	M24 x 120	1500	2	33,80

Finishing: Zincato / Galvanized

Categoria commerciale: 1M

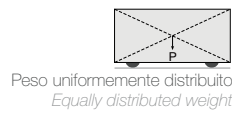
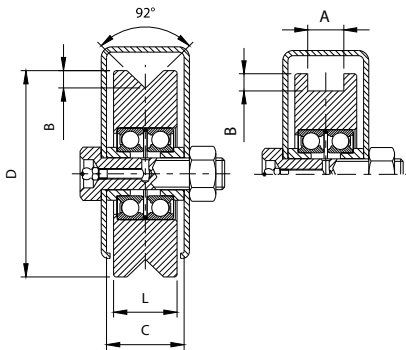

323 W

Ruota con ingrassatore
gola semitonda
Grease gun wheel with half-rounded groove
Galet à graisseur avec gorge demi-ronde
Schiebetorrolle mit Rundrille und Schmiernippel
Rueda con engrasador canal semiredondo
Колесо с масляной с полукруглым пазом

1 CUSCINETTO
1 BEARING



CODE	ART.	B	C	D	L	R	Perno Wheel Pin	Portata ruota-Kg Capacity wheel-Kg	Box info			
									Pcs per pack	Kg		
11507540 001	323-100	9,5	34	∅ 97	26	10,5	∅ 19	∅ 19	M18 x 70	380	8	9,70
11507550 001	323-120	9,5	44	∅ 117	29	10,5	∅ 19	∅ 19	M18 x 70	400	6	12,40
11507570 001	323-160	9,5	44	∅ 157	31	11,5	∅ 19	∅ 19	M20 x 80	710	2	8,20
11507580 001	323-200	9,5	44	∅ 197	31	11,5	∅ 19	∅ 19	M20 x 80	750	2	13,30
11507590 001	323-250	9,5	54	∅ 247	34	11,5	∅ 19	∅ 19	M24 x 100	800	2	24,40

Finishing: Zincato / Galvanized

Categoria commerciale: 1M

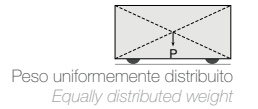
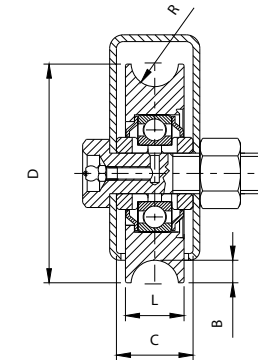

322 W

Ruota con ingrassatore gola Y
Grease gun wheel with Y groove
Galet à graisseur gorge Y
Schiebetorrolle Y-Rille mit Schmiernippel
Rueda con engrasador canal Y
Колесо с масляной с пазом Y

2 CUSCINETTI
2 BEARINGS



CODE	ART.	B	C	D	L	Perno Wheel Pin	Portata ruota-Kg Capacity wheel-Kg	Box info	
								Pcs per pack	Kg
11507240 001	322Y-100	13	44	∅ 98	36	M18 x 70	580	8	15,00
11507241 001	322Y-100	13	54	∅ 98	36	M18 x 80	580	8	15,00
11507250 001	322Y-120	13	44	∅ 117	36	M18 x 70	600	6	16,10
11507251 001	322Y-120	13	54	∅ 117	36	M18 x 80	600	6	16,10
11507270 001	322Y-160	13,5	44	∅ 157	38	M18 x 70	960	2	10,40
11507271 001	322Y-160	13,5	54	∅ 157	38	M18 x 80	960	2	10,40
11507272 001	322Y-160	13,5	74	∅ 157	38	M18 x 100	960	2	10,40
11507280 001	322Y-200	13,5	44	∅ 197	38	M18 x 70	1000	2	16,40
11507281 001	322Y-200	13,5	54	∅ 197	38	M18 x 80	1000	2	16,40
11507282 001	322Y-200	13,5	74	∅ 197	38	M18 x 100	1000	2	16,40
11507290 001	322Y-250	17,5	72	∅ 247	48	M24 x 120	1500	2	33,80

Finishing: Zincato / Galvanized

Categoria commerciale: 1M

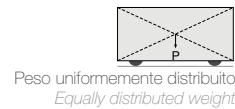
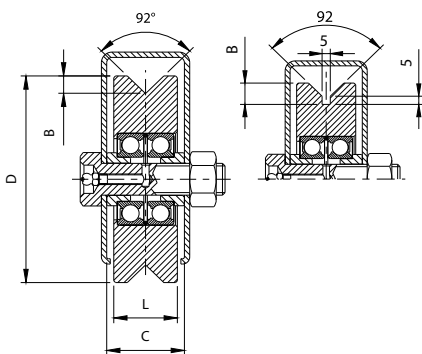

324 W

Ruota con ingrassatore
gola semitonda
Grease gun wheel with half-rounded groove
Galet à graisseur avec gorge demi-ronde
Schiebetorrolle mit Rundrille und Schmiernippel
Rueda con engrasador canal semiredondo
Колесо с масляной с полукруглым пазом

2 CUSCINETTI
2 BEARINGS



CODE	ART.	B	C	D	L	R	Perno Wheel Pin	Portata ruota-Kg Capacity wheel-Kg	Box info			
									Pcs per pack	Kg		
11508040 001	324-100	9,5	44	∅ 98	36	10,5	∅ 19	∅ 19	M18 x 70	580	8	13,80
11508041 001	324-100	9,5	54	∅ 98	36	10,5	∅ 19	∅ 19	M18 x 80	580	8	13,80
11508050 001	324-120	9,5	44	∅ 117	36	10,5	∅ 19	∅ 19	M18 x 70	600	6	15,60
11508051 001	324-120	9,5	54	∅ 117	36	10,5	∅ 19	∅ 19	M18 x 80	600	6	15,60
11508070 001	324-160	9,5	44	∅ 157	38	11,5	∅ 19	∅ 19	M18 x 70	960	2	10,10
11508071 001	324-160	9,5	54	∅ 157	38	11,5	∅ 19	∅ 19	M18 x 80	960	2	10,10
11508072 001	324-160	9,5	74	∅ 157	38	11,5	∅ 19	∅ 19	M18 x 100	960	2	10,10
11508080 001	324-200	9,5	44	∅ 197	38	11,5	∅ 19	∅ 19	M18 x 70	1000	2	16,80
11508081 001	324-200	9,5	54	∅ 197	38	11,5	∅ 19	∅ 19	M18 x 80	1000	2	16,80
11508082 001	324-200	9,5	74	∅ 197	38	11,5	∅ 19	∅ 19	M18 x 100	1000	2	16,80
11508090 001	324-250	9,5	72	∅ 247	48	11,5	∅ 19	∅ 19	M24 x 120	1500	2	34,60

Finishing: Zincato / Galvanized

Categoria commerciale: 1M

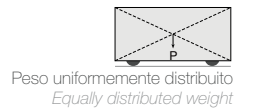
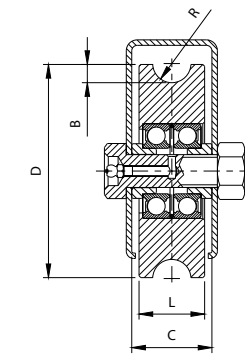

325 W

Ruota con supporto esterno gola V
Wheel with external support, V groove
Galet avec support extérieur, gorge V
Schiebetorrolle mit Außenstützplatte und V-Rille
Rueda con soporte exterior canal V
Колесо с наружным суппортом с пазом V

1 CUSCINETTO
1 BEARING



CODE	ART.	B	C	D	F	G	I	L	M	N	Portata ruota-Kg Capacity wheel-Kg		Box info	
											Pcs per pack	Kg	Pcs per pack	Kg
11509010 001	325V-60	7	25	∅ 60	∅ 7	55,5	63	16,5	80	65,5	100	12	4,70	
11509020 001	325V-80	7	36	∅ 78	∅ 9	71	90	24	117	84,5	200	6	6,10	
11509030 001	325V-90	7,5	40	∅ 88	∅ 9	90	110	21	146	101	210	6	8,12	
11509040 001	325V-100	7,5	40	∅ 98	∅ 9	90	110	21	146	106	220	6	9,50	

Finishing: Zincato / Galvanized

Categoria commerciale: 1M

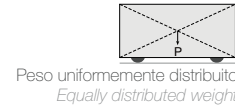
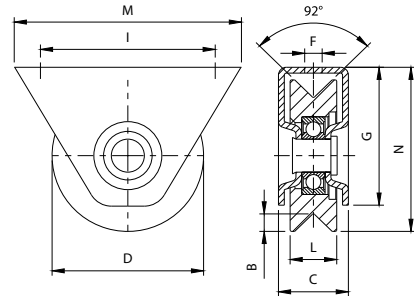

325 U

Ruota con supporto esterno gola U
Wheel with external support, U groove
Galet avec support extérieur, gorge U
Schiebetorrolle mit Außenstützplatte und U-Rille
Rueda con soporte exterior canal U
Колесо с наружным суппортом с пазом U

1 CUSCINETTO
1 BEARING



CODE	ART.	A	B	C	D	F	G	I	L	M	N	Portata ruota-Kg Capacity wheel-Kg		Box info	
												Pcs per pack	Kg	Pcs per pack	Kg
11508510 001	325U-60	8	7	25	∅ 60	∅ 7	55,5	63	16,5	80	65,5	100	12	4,70	
11508520 001	325U-80	8	7	36	∅ 78	∅ 9	71	90	24	117	84,5	200	6	6,10	

Finishing: Zincato / Galvanized

Categoria commerciale: 1M

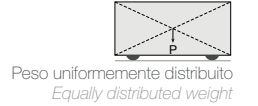
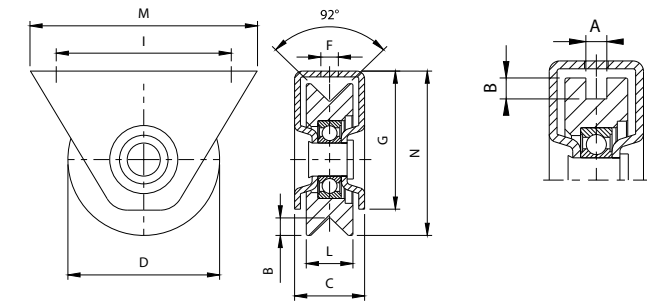

Mounting instructions art. 325V

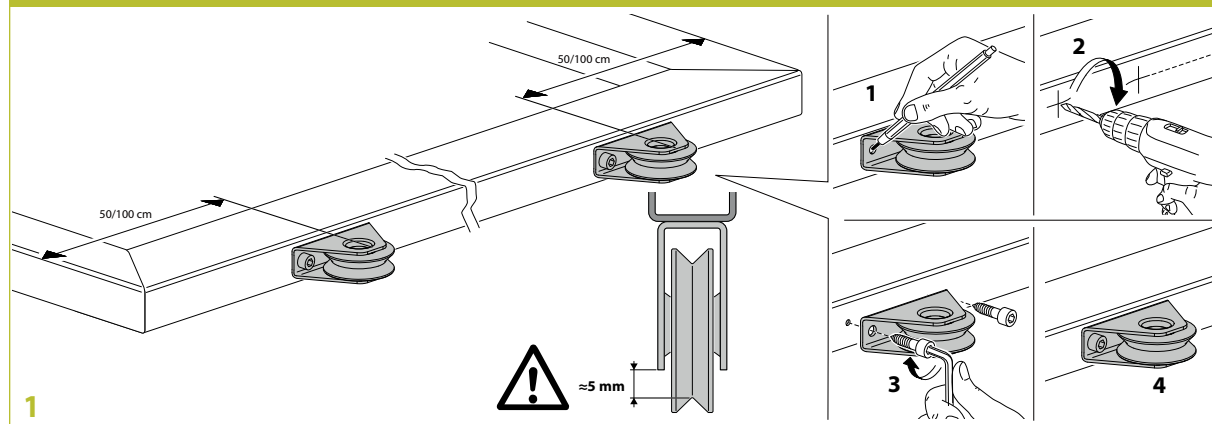

1

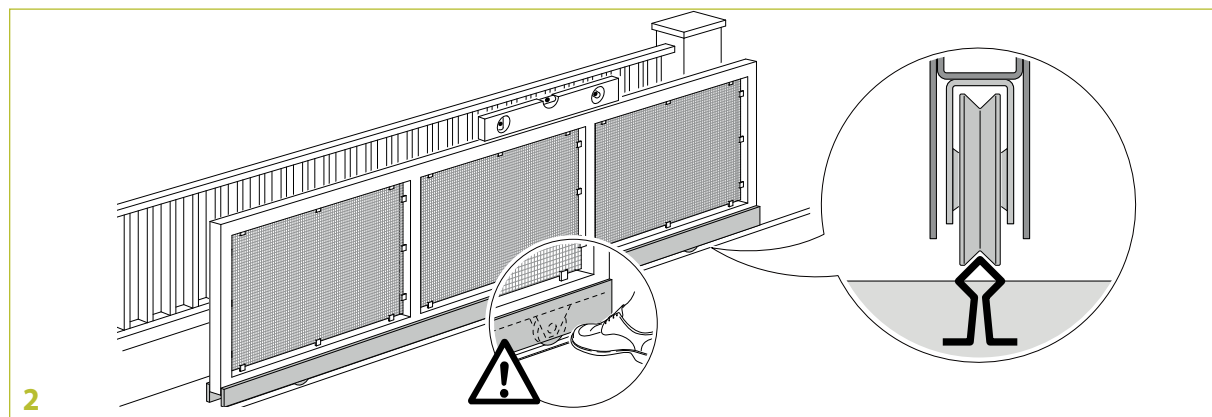

2

326 W

Ruota con supporto esterno gola V
Wheel with external support, V groove
Galet avec support extérieur, gorge V
Schiebetorrolle mit Außenstützplatte und V-Rille
Rueda con soporte exterior canal V
Колесо с наружным суппортом с пазом V

2 CUSCINETTI
2 BEARINGS



CODE	ART.	B	C	D	F	G	I	L	M	N	Portata ruota-Kg Capacity wheel-Kg		Box info	
											Pcs per pack	Kg	Pcs per pack	Kg
11509240 001	326V-100	9,5	39	∅ 98	∅ 9	90	110	28	146	106	400	6	11,10	

Finishing: Zincato / Galvanized

Categoria commerciale: 1M

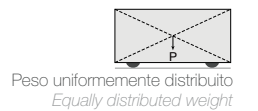
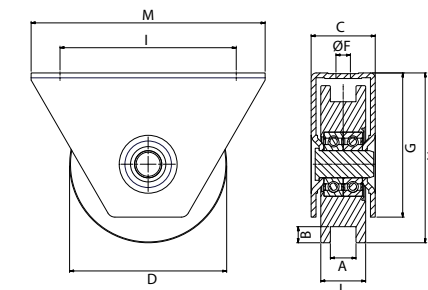

326 U

Ruota con supporto esterno gola U
Wheel with external support, U groove
Galet avec support extérieur, gorge U
Schiebetorrolle mit Außenstützplatte und U-Rille
Rueda con soporte exterior canal U
Колесо с наружным суппортом с пазом U

2 CUSCINETTI
2 BEARINGS



CODE	ART.	B	C	D	F	G	I	L	M	N	Portata ruota-Kg Capacity wheel-Kg		Box info	
											Pcs per pack	Kg	Pcs per pack	Kg
11508740 001	326U-100	9,5	39	∅ 98	∅ 9	90	110	28	146	106	400	6	11,10	

Finishing: Zincato / Galvanized

Categoria commerciale: 1M

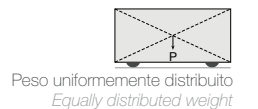
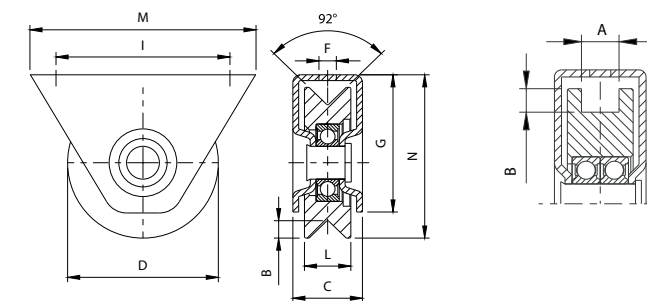

327 W

Ruota con supporto esterno
gola semitonda

Wheel with external support, half-rounded groove
Galet avec support extérieur, gorge demi-ronde
Schiebetorrolle mit Außenstützplatte und Rundrille
Rueda con soporte exterior canal semiredondo
Колесо с наружным суппортом с полукруглым пазом

1 CUSCINETTO
1 BEARING



CODE	ART.	B	C	D	F	G	I	L	M	N	R	Portata ruota-Kg Capacity wheel-Kg		Box info		
												Pcs per pack	Kg			
11509510 001	327-60	4	25	Ø 60	Ø 7	55,5	63	16,5	80	65,5	4,5	-	-	100	12	5,10
11509520 001	327-80	7,5	36	Ø 78	Ø 9	71	90	24	117	84,5	8,5	Ø 15	Ø 15	200	6	5,50
11509525 001	327-80S	9,5	36	Ø 78	Ø 9	71	90	24	117	84,5	10,3	Ø 19	Ø 19	200	6	5,00

Finishing: Zincato / Galvanized

Categoria commerciale: 1M

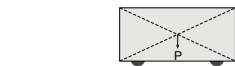
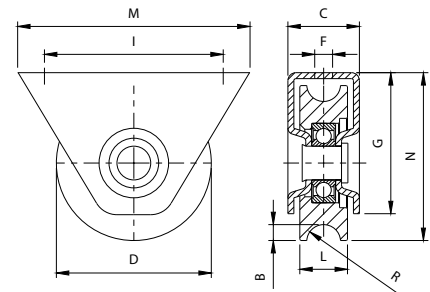

Peso uniformemente distribuito
Equally distributed weight

330 W

Ruota con piastre gola V

Wheel with external plates, V groove
Galet avec platine extérieure, gorge V
Schiebetorrolle mit Außenplatten und V-Rille
Rueda con placas canal V
Колесо с пластинами с пазом V

1 CUSCINETTO
1 BEARING



CODE	ART.	B	C	D	L	M	N	O	P	S	Portata ruota-Kg Capacity wheel-Kg		Box info	
											Pcs per pack	Kg		
11510510 001	330V-60	7	24	Ø 60	16,5	62	10	34	47,5	2,5	100	12	4,00	
11510515 001	330V-70	7	29	Ø 68	20	70	10,5	40	54,5	3	170	6	3,40	
11510520 001	330V-80	7	29	Ø 78	20	80	15,5	40	59,5	3	180	6	4,40	
11510530 001	330V-90	7,5	32	Ø 88	21	90	17,5	43	67,5	3	190	6	6,50	
11510540 001	330V-100	7,5	33	Ø 98	21	100	20	44	75	3	200	6	7,90	
11510550 001	330V-120	9	33	Ø 117	25	120	19,5	44	94,5	3	220	2	3,90	
11510560 001	330V-140	9	33	Ø 137	25	140	23	48	111	3	240	2	6,10	

Finishing: Zincato / Galvanized

Categoria commerciale: 1M

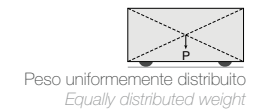
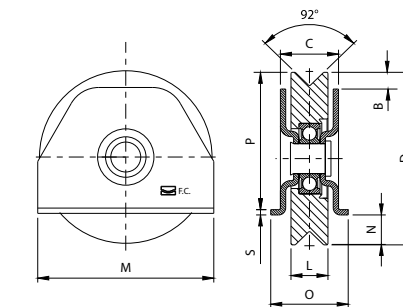

Peso uniformemente distribuito
Equally distributed weight

328 W

Ruota con supporto esterno
gola semitonda

Wheel with external support, half-rounded groove
Galet avec support extérieur, gorge demi-ronde
Schiebetorrolle mit Außenstützplatte und Rundrille
Rueda con soporte exterior canal semiredondo
Колесо с наружным суппортом с полукруглым пазом

2 CUSCINETTI
2 BEARINGS



CODE	ART.	B	C	D	F	G	I	L	M	N	R	Portata ruota-Kg Capacity wheel-Kg		Box info		
												Pcs per pack	Kg			
11509740 001	328-100	9,5	39	Ø 98	Ø 9	90	110	28	146	106	10,5	Ø 19	Ø 19	400	6	10,50

Finishing: Zincato / Galvanized

Categoria commerciale: 1M

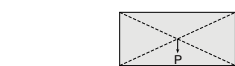
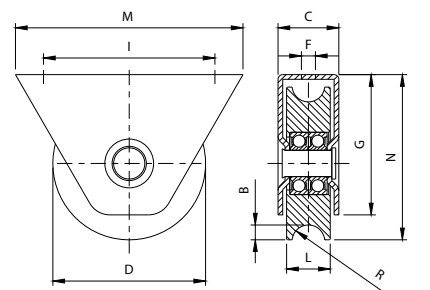

Peso uniformemente distribuito
Equally distributed weight

Mounting instructions art. 330V

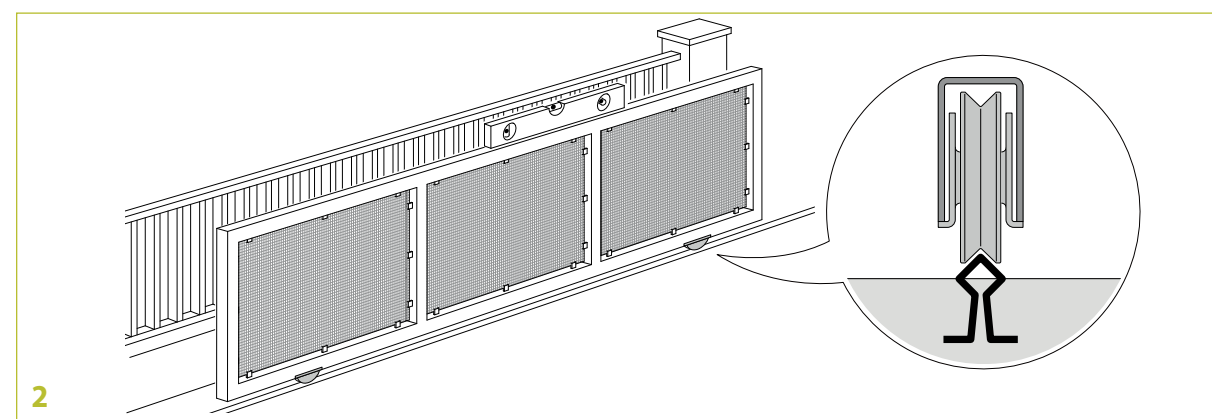
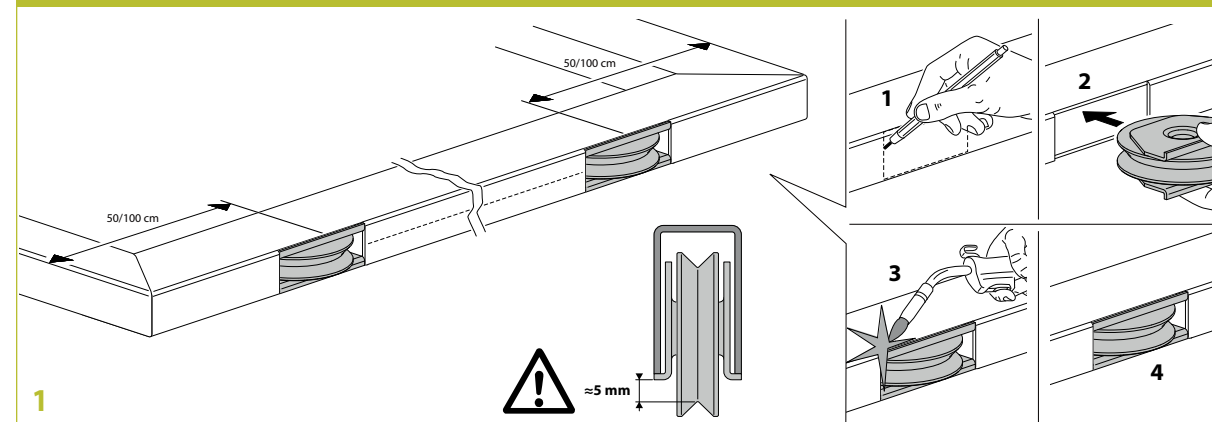

330 U

Ruota con piastre gola U
Wheel with external plates, U groove Galet
Gavec avec platine extérieure, gorge U
Schiebetorrolle mit Außenstützplatte und U-Rille
Rueda con placas canal U
Колесо с пластинами с пазом U

1 CUSCINETTO
1 BEARING



CODE	ART.	A	B	C	D	L	M	N	O	P	S	Portata ruota-Kg Capacity wheel-Kg		Box info	
												Pcs per pack	Kg		
11510010 001	330U-60	8	7	24	Ø 60	16,5	62	10	34	47,5	2,5	100	12	4,00	
11510015 001	330U-70	8	8	29	Ø 68	20	70	10,5	40	54,5	3	170	6	3,40	
11510020 001	330U-80	8	8	29	Ø 78	20	80	15,5	40	59,5	3	180	6	4,40	
11510030 001	330U-90	8	8	32	Ø 88	21	90	17,5	43	67,5	3	190	6	6,50	
11510040 001	330U-100	8	8	33	Ø 98	21	100	20	44	75	3	200	6	7,90	
11510050 001	330U-120	16	10	33	Ø117	25	120	19,5	44	94,5	3	220	2	3,90	
11510060 001	330U-140	16	10	33	Ø137	25	140	23	48	111	3	240	2	6,10	

Finishing: Zincato / Galvanized

Categoria commerciale: 1M

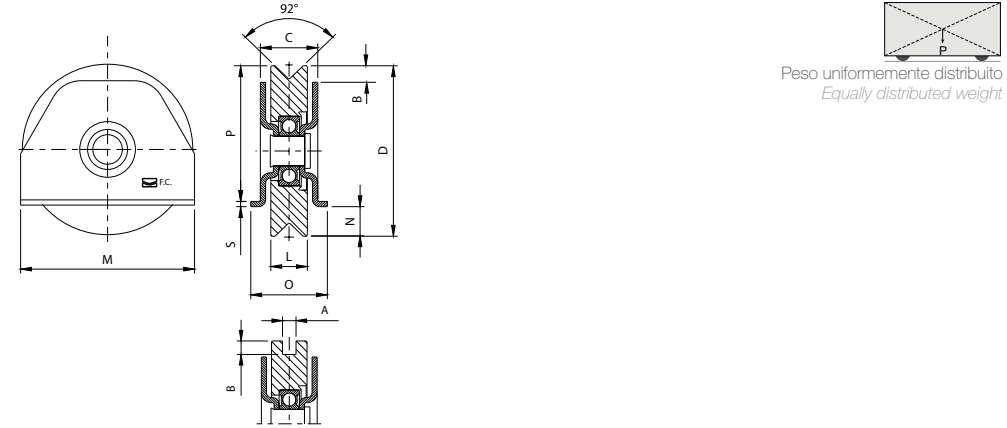

332 W

Ruota con piastre gola semitonda
Wheel with external plates, half-rounded groove
Galet avec platine extérieure, gorge demi-ronde
Schiebetorrolle mit Außenstützplatte und Rundrille
Rueda con placas canal semicircular
Колесо с пластинами с полукруглым пазом

1 CUSCINETTO
1 BEARING



CODE	ART.	B	C	D	L	M	N	O	P	R	S	Portata ruota-Kg Capacity wheel-Kg		Box info		
												Pcs per pack	Kg			
11511010 001	332-60	4	24	Ø 60	16,5	62	10	34	47,5	4,5	2,5	-	-	100	12	4,00
11511015 001	332-70	7,5	29	Ø 68	20	70	10,5	40	54,5	8,5	3	Ø 15	Ø 15	170	6	3,30
11511020 001	332-80	7,5	29	Ø 78	20	80	15,5	40	59,5	8,5	3	Ø 15	Ø 15	180	6	4,10
11511025 001	332-80S	9,5	32	Ø 78	24	80	15,5	40	59,5	10,5	3	Ø 19	Ø 19	180	6	4,10
11511030 001	332-90	7,5	32	Ø 88	21	90	17,5	43	67,5	8,5	3	Ø 15	Ø 15	190	6	5,70
11511035 001	332-90S	9,5	32	Ø 88	24	90	17,5	43	67,5	10,5	3	Ø 19	Ø 19	190	6	5,70
11511040 001	332-100	7,5	32	Ø 98	21	100	20	44	75	8,5	3	Ø 15	Ø 15	200	6	7,40
11511045 001	332-100S	9,5	32	Ø 98	24	100	20	44	75	10,5	3	Ø 19	Ø 19	200	6	7,60
11511050 001	332-120	9,5	33	Ø117	25	120	19,5	44	94,5	10,5	3	Ø 19	Ø 19	220	2	4,00
11511060 001	332-140	9,5	33	Ø137	25	140	23	48	111	10,5	3	Ø 19	Ø 19	240	2	5,70

Finishing: Zincato / Galvanized

Categoria commerciale: 1M

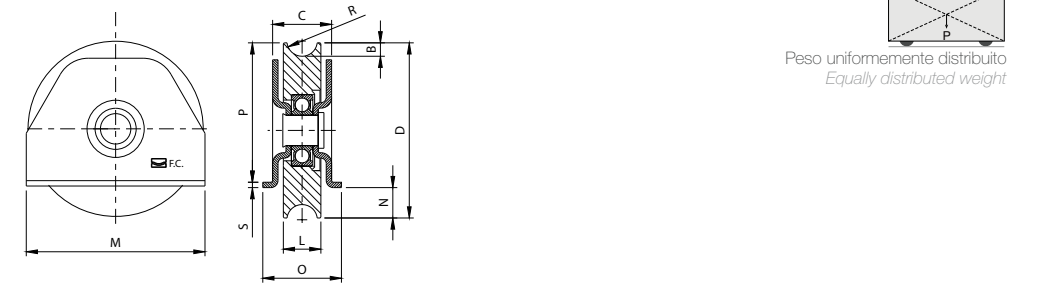

330 W

Ruota con piastre gola Y
Wheel with external plates, Y groove
Galet avec platine extérieure, gorge Y
Schiebetorrolle mit Außenstützplatte und Y-Rille
Rueda con placas canal Y
Колесо с пластинами с пазом Y

1 CUSCINETTO
1 BEARING



CODE	ART.	B	C	D	L	M	N	O	P	S	Portata ruota-Kg Capacity wheel-Kg		Box info	
											Pcs per pack	Kg		
11510710 001	330Y-60	9	24	Ø 60	16,5	62	10	34	47,5	2,5	100	12	4,00	
11510715 001	330Y-70	9,5	29	Ø 68	20	70	10,5	40	54,5	3	170	6	3,40	
11510720 001	330Y-80	9,5	29	Ø 78	20	80	15,5	40	59,5	3	180	6	4,40	
11510730 001	330Y-90	10,5	32	Ø 88	21	90	17,5	43	67,5	3	190	6	6,50	
11510740 001	330Y-100	10,5	33	Ø 98	21	100	20	44	75	3	200	6	7,90	
11510750 001	330Y-120	12,5	33	Ø 117	25	120	19,5	44	94,5	3	220	2	3,90	
11510760 001	330Y-140	12,5	33	Ø 137	25	140	23	48	111	3	240	2	6,10	

Finishing: Zincato / Galvanized

Categoria commerciale: 1M

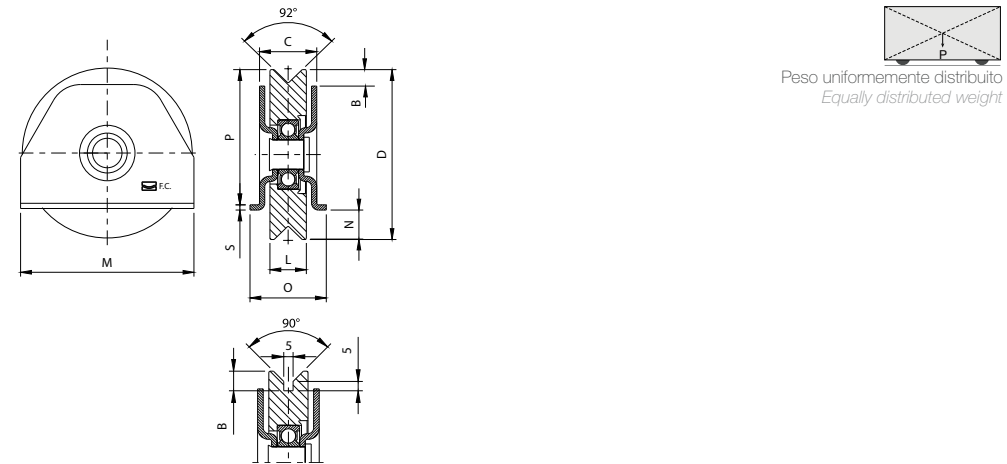

333 W

Ruota con piastre gola V
Wheel with external plates, V groove
Galet avec platine extérieure, gorge V
Schiebetorrolle mit Außenstützplatte und V-Rille
Rueda con placas canal V
Колесо с пластинами с пазом V

2 CUSCINETTI
2 BEARINGS



CODE	ART.	B	C	D	L	M	N	O	P	S	Portata ruota-Kg Capacity wheel-Kg		Box info	
											Pcs per pack	Kg		
11512040 001	333V-100	9,5	41	Ø 98	28	100	20	52	75	3	380	6	9,90	
11512050 001	333V-120	9,5	41	Ø 117	28	120	19,5	52	94,5	3	400	2	4,90	
11512060 001	333V-140	9,5	41	Ø 137	28	140	23	56	111	3	420	2	6,90	

Finishing: Zincato / Galvanized

Categoria commerciale: 1M

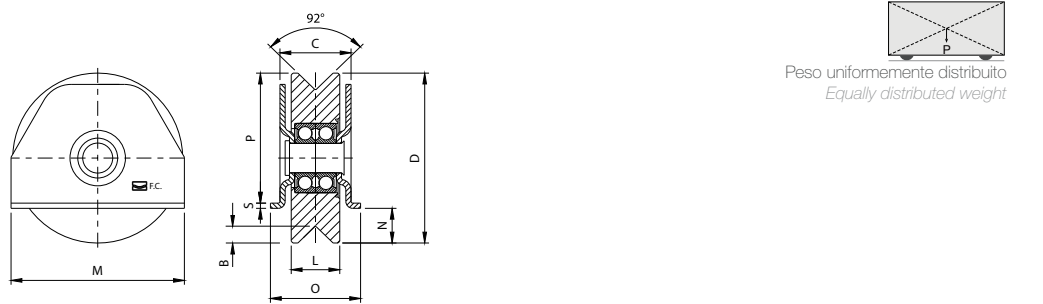

333 U

Ruota con piastre gola U
Wheel with external plates, U groove
Galet avec platine extérieure, gorge U
Schiebetorrolle mit Außenstützplatte und U-Rille
Rueda con placas canal U
Колесо с пластинами с пазом U

2 CUSCINETTI
2 BEARINGS



CODE	ART.	A	B	C	D	L	M	N	O	P	S	Portata ruota-Kg Capacity wheel-Kg		Box info	
												Pcs per pack	Kg	Pcs per pack	Kg
11511540 001	333U-100	16	10	41	Ø98	28	100	20	52	75	3	380	6	9,90	
11511550 001	333U-120	21	10	41	Ø117	28	120	19,5	52	94,5	3	400	2	4,90	
11511560 001	333U-140	21	10	41	Ø137	28	140	23	56	111	3	420	2	6,90	

Finishing: Zincato / Galvanized

Categoria commerciale: 1M

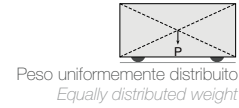
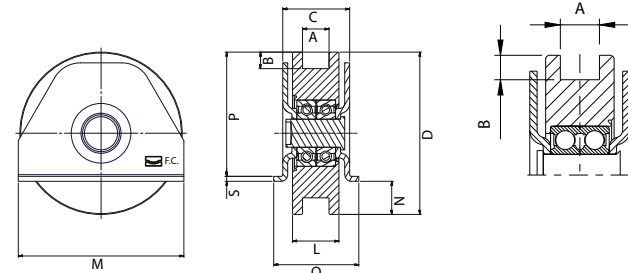

333 W

Ruota con piastre gola Y
Wheel with external plates, Y groove
Galet avec support extérieur, gorge Y
Schiebetorrolle mit Außenstützplatte und Y-Rille
Rueda con placas canal Y
Колесо с пластинами с пазом Y

2 CUSCINETTI
2 BEARINGS



CODE	ART.	B	C	D	L	M	N	O	P	S	Portata ruota-Kg Capacity wheel-Kg		Box info	
											Pcs per pack	Kg	Pcs per pack	Kg
11512240 001	333Y-100	12,5	41	Ø98	28	100	20	52	75	3	380	6	9,90	
11512250 001	333Y-120	12,5	41	Ø117	28	120	19,5	52	94,5	3	400	2	4,90	
11512260 001	333Y-140	12,5	41	Ø137	28	140	23	56	111	3	420	2	6,90	

Finishing: Zincato / Galvanized

Categoria commerciale: 1M

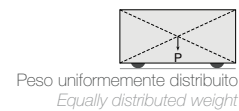
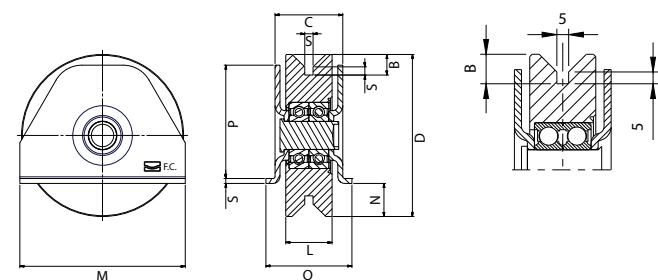

334 W

Ruota con piastre gola semitonda
Wheel with external plates, half-rounded groove
Galet avec support extérieur, gorge demi-ronde
Schiebetorrolle mit Außenstützplatte und Rundrille
Rueda con placas canal semicircular
Колесо с пластинами с полукруглым пазом

2 CUSCINETTI
2 BEARINGS



CODE	ART.	B	C	D	L	M	N	O	P	R	S	Portata ruota-Kg Capacity wheel-Kg		Box info	
												Pcs per pack	Kg	Pcs per pack	Kg
11512540 001	334-100	9,5	41	Ø98	28	100	20	52	75	10,5	3	Ø 19 Ø 19	380	6	9,20
11512550 001	334-120	9,5	41	Ø117	28	120	19,5	52	94,5	10,5	3	Ø 19 Ø 19	400	2	4,60
11512560 001	334-140	9,5	41	Ø137	28	140	23	56	111	10,5	3	Ø 19 Ø 19	420	2	6,60

Finishing: Zincato / Galvanized

Categoria commerciale: 1M

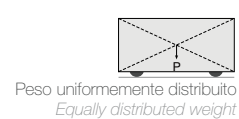
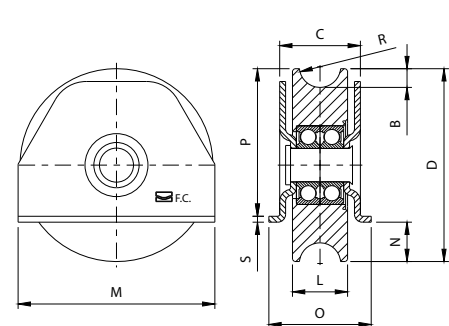

335 W

Ruota con supporto interno gola V
Wheel with internal plate, V groove
Galet avec platine interne, gorge V
Schiebetorrolle mit Innenstützplatte und V-Rille
Rueda con soporte interior canal V
Колесо с внутренним суппортом с пазом V

1 CUSCINETTO
1 BEARING



CODE	ART.	B	C	D	E	F	G	I	L	M	N	P	S	Portata ruota-Kg Capacity wheel-Kg		Box info	
														Pcs per pack	Kg	Pcs per pack	Kg
11513520 001	335V-80	7	32	Ø78	14	Ø9	38	110	20	135	14	50	3	180	6	4,90	
11513530 001	335V-90	7,5	32	Ø88	14,5	Ø9	55,5	130	21	155	8,5	65	3	190	6	6,70	
11513540 001	335V-100	7,5	32	Ø98	14,5	Ø9	55,5	130	21	155	13,5	70	3	200	6	8,00	
11513550 001	335V-120	9	37	Ø117	15	Ø9	65	155	25	185	16,5	85,5	3	220	2	4,50	
11513560 001	335V-140	9	40	Ø137	17	Ø11	77	175	25	205	15	105	3	240	2	6,20	

Finishing: Zincato / Galvanized

Categoria commerciale: 1M

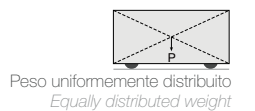
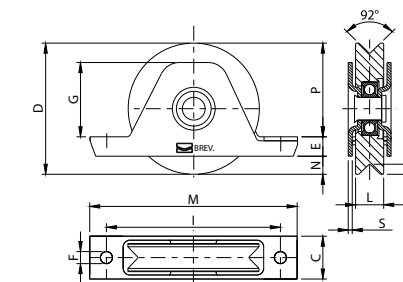

Mounting instructions art. 335V

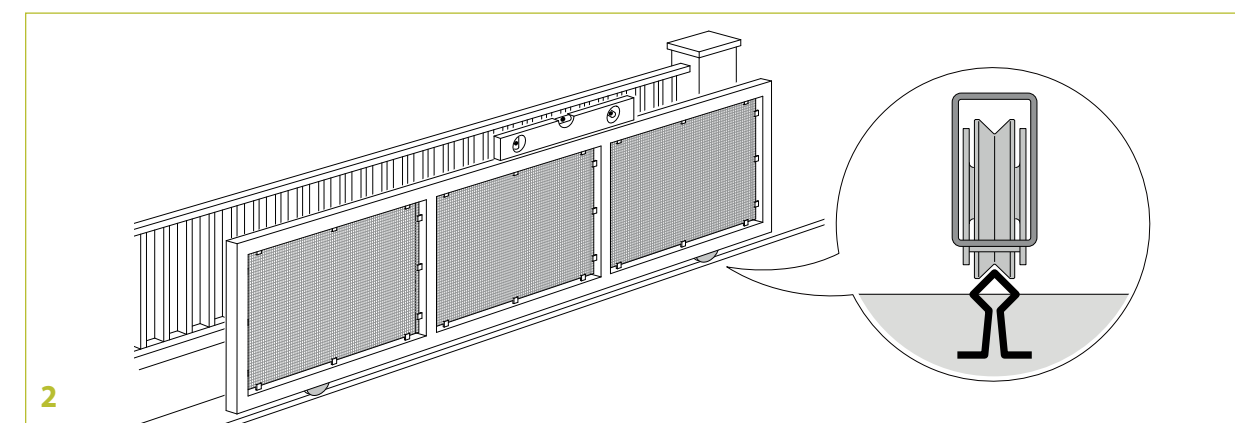
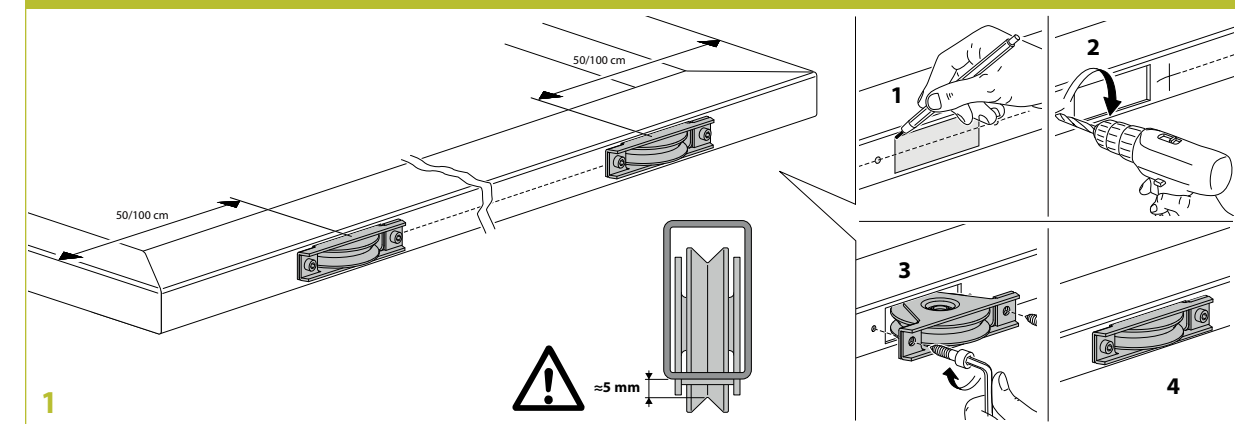

335i W

Ruota con supporto interno gola V
Wheel with internal plate, V groove
Galet avec platine interne, gorge V
Schiebetorrolle mit Innenstützplatte und V-Rille
Rueda con soporte interior canal V
Колесо с внутренним суппортом с пазом V

1 CUSCINETTO
1 BEARING



CODE	ART.	B	C	D	E	F	G	I	L	M	N	P	S	Portata ruota-Kg Capacity wheel-Kg		Box info	
														Pcs per pack	Kg		
11513630	335i-V90	7,5	33	Ø88	14,5	Ø9	55,5	130	21	155	8,5	65	3	190	2	2,30	
11513640	335i-V100	7,5	33	Ø98	14,5	Ø9	55,5	130	21	155	13,5	70	3	200	2	2,80	
11513650	335i-V120	9	38	Ø117	15	Ø9	65	155	25	185	16,5	85,5	3	220	2	4,50	

Finishing: Inox / Stainless steel

Categoria commerciale: 1M

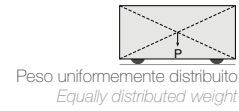
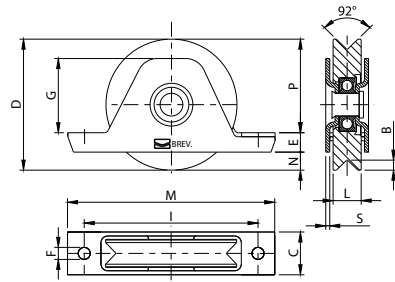

335 W

Ruota con supporto interno gola Y
Wheel with external plates, Y groove
Galet avec platine interne, gorge Y
Schiebetorrolle mit Außenstützplatte und Rundrille
Rueda con soporte interior canal U
Колесо с внутренним суппортом с пазом U

1 CUSCINETTO
1 BEARING



CODE	ART.	B	C	D	E	F	G	I	L	M	N	P	S	Portata ruota-Kg Capacity wheel-Kg		Box info	
														Pcs per pack	Kg		
11513720 001	335Y-80	9,5	32	Ø78	14	Ø9	38	110	20	135	14	50	3	180	6	4,90	
11513730 001	335Y-90	10,5	32	Ø88	14,5	Ø9	55,5	130	21	155	8,5	65	3	190	6	6,70	
11513740 001	335Y-100	10,5	32	Ø98	14,5	Ø9	55,5	130	21	155	13,5	70	3	200	6	8,00	
11513750 001	335Y-120	12,5	37	Ø117	15	Ø9	65	155	25	185	16,5	85,5	3	220	2	4,50	
11513760 001	335Y-140	12,5	40	Ø137	17	Ø11	77	175	25	205	15	105	3	240	2	6,20	

Finishing: Zincato / Galvanized

Categoria commerciale: 1M

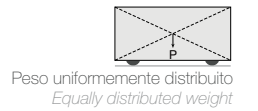
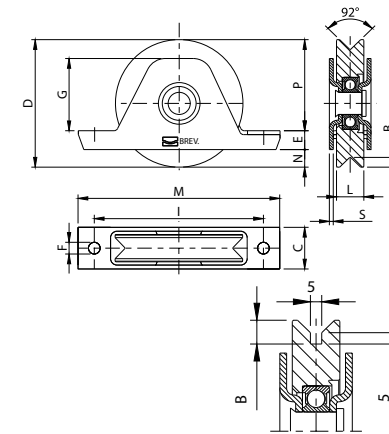

335 W

Ruota con supporto interno gola U
Wheel with external plates, U groove
Galet avec platine interne, gorge U
Schiebetorrolle mit Außenstützplatte und Rundrille
Rueda con soporte interior canal U
Колесо с внутренним суппортом с пазом U

1 CUSCINETTO
1 BEARING



CODE	ART.	A	B	C	D	E	F	G	I	L	M	N	P	S	Portata ruota-Kg Capacity wheel-Kg		Box info	
															Pcs per pack	Kg		
11513020 001	335U-80	8	8	32	Ø78	14	Ø9	38	110	20	135	14	50	3	180	6	4,90	
11513030 001	335U-90	8	8	32	Ø88	14,5	Ø9	55,5	130	21	155	8,5	65	3	190	6	6,70	
11513040 001	335U-100	8	8	32	Ø98	14,5	Ø9	55,5	130	21	155	13,5	70	3	200	6	8,00	
11513050 001	335U-120	16	10	37	Ø117	15	Ø9	65	155	25	185	16,5	85,5	3	220	2	4,50	
11513060 001	335U-140	16	10	40	Ø137	17	Ø11	77	175	25	205	15	105	3	240	2	6,20	

Finishing: Zincato / Galvanized

Categoria commerciale: 1M

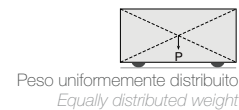
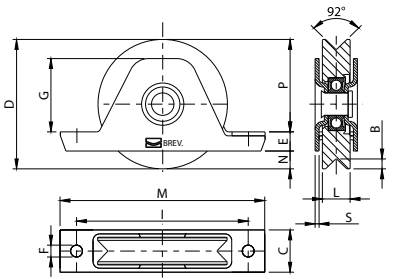

336 W

Ruota con supporto interno gola V
Wheel with internal plate, V groove
Galet avec platine interne, gorge V
Schiebetorrolle mit Innenstützplatte und V-Rille
Rueda con soporte interior canal U
Колесо с внутренним суппортом с пазом U

2 CUSCINETTI
2 BEARINGS



CODE	ART.	B	C	D	E	F	G	I	L	M	N	P	S	Portata ruota-Kg Capacity wheel-Kg		Box info	
														Pcs per pack	Kg		
11514530 001	336V-90	8,5	32	Ø88	14,5	Ø9	55,5	130	24	155	9	64,5	3	300	6	7,60	
11514540 001	336V-100	8,5	32	Ø98	14,5	Ø9	55,5	130	24	155	14	69,5	3	380	6	9,20	
11514550 001	336V-120	10	37	Ø117	15	Ø9	65	155	28	185	16,5	85,5	3	400	2	5,00	
11514560 001	336V-140	10	40	Ø137	17	Ø11	77	175	28	205	15	105	3	420	2	7,00	
11514570 001	336V-160	10	42	Ø157	20	Ø11	87	195	33	225	20,5	116,5	3	640	2	10,60	
11514580 001	336V-200	10	42	Ø197	22,5	Ø11	107,5	240	31	275	26,5	148	3	700	2	16,80	

Finishing: Zincato / Galvanized

Categoria commerciale: 1M

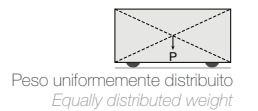
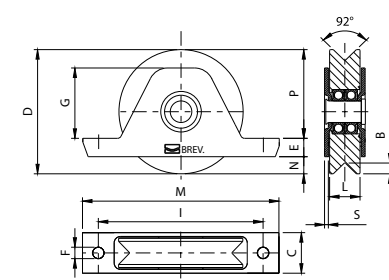

336i W

Ruota con supporto interno gola V
Wheel with internal plate, V groove
Galet avec platine interne, gorge V
Schiebetorrolle mit innenstützplatte und V-Rille
Rueda con soporte interior canal V
Колесо с внутренним суппортом с пазом V

2 CUSCINETTI
2 BEARINGS



CODE	ART.	B	C	D	E	F	G	I	L	M	N	P	S	Portata ruota-Kg Capacity wheel-Kg		Box info	
														Pcs per pack	Kg		
11514630	336i-V90	8,5	33	Ø 88	14,5	Ø 9	55,5	130	24	155	8,5	65	3	300	2	2,30	
11514640	336i-V100	8,5	33	Ø 98	14,5	Ø 9	55,5	130	24	155	13,5	70	3	380	2	2,80	
11514650	336i-V120	10	38	Ø 117	15	Ø 9	65	155	28	185	16,5	85,5	3	400	2	4,50	

Finishing: Inox / Stainless steel

Categoria commerciale: 2M

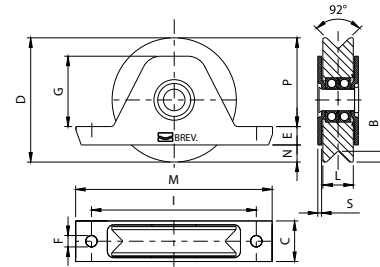

336 W

Ruota con supporto interno gola Y
Wheel with internal plate, Y groove
Galet avec platine interne, gorge Y
Schiebetorrolle mit innenstützplatte und Y-Rille
Rueda con soporte interior canal Y
Колесо с внутренним суппортом с пазом Y

2 CUSCINETTI
2 BEARINGS



CODE	ART.	B	C	D	E	F	G	I	L	M	N	P	S	Portata ruota-Kg Capacity wheel-Kg		Box info	
														Pcs per pack	Kg		
11514730 001	336Y-90	12,5	32	Ø 88	14,5	Ø 9	55,5	130	24	155	9	64,5	3	300	6	7,60	
11514740 001	336Y-100	12,5	32	Ø 98	14,5	Ø 9	55,5	130	24	155	14	69,5	3	380	6	9,20	
11514750 001	336Y-120	12,5	37	Ø 117	15	Ø 9	65	155	28	185	16,5	85,5	3	400	2	5,00	
11514760 001	336Y-140	12,5	40	Ø 137	17	Ø 11	77	175	28	205	15	105	3	420	2	7,00	
11514770 001	336Y-160	12,5	42	Ø 157	20	Ø 11	87	195	33	225	20,5	116,5	3	640	2	10,60	
11514780 001	336Y-200	12,5	42	Ø 197	22,5	Ø 11	107,5	240	31	275	26,5	148	3	700	2	16,80	

Finishing: Zincato / Galvanized

Categoria commerciale: 1M

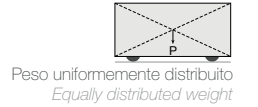
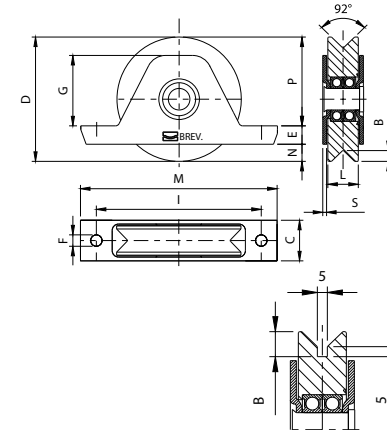

336 W

Ruota con supporto interno gola U
Wheel with external plates, U groove
Galet avec platine interne, gorge U
Schiebetorrolle mit Außenstützplatte und Rundrille
Rueda con soporte interior canal U
Колесо с внутренним суппортом с пазом U

2 CUSCINETTI
2 BEARINGS



CODE	ART.	A	B	C	D	E	F	G	I	L	M	N	P	S	Portata ruota-Kg Capacity wheel-Kg		Box info	
															Pcs per pack	Kg		
11514030 001	336U-90	16	10	32	Ø 88	14,5	Ø 9	55,5	130	24	155	9	64,5	3	300	6	7,60	
11514040 001	336U-100	16	10	32	Ø 98	14,5	Ø 9	55,5	130	24	155	14	69,5	3	380	6	9,20	
11514050 001	336U-120	21	10	37	Ø 117	15	Ø 9	65	155	28	185	16,5	85,5	3	400	2	5,00	
11514060 001	336U-140	21	10	40	Ø 137	17	Ø 11	77	175	28	205	15	105	3	420	2	7,00	
11514070 001	336U-160	21	10	42	Ø 157	20	Ø 11	87	195	33	225	20,5	116,5	3	640	2	10,60	
11514080 001	336U-200	21	10	42	Ø 197	22,5	Ø 11	107,5	240	31	275	26,5	148	3	700	2	16,80	

Finishing: Zincato / Galvanized

Categoria commerciale: 1M

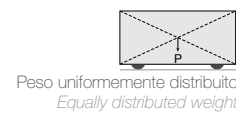
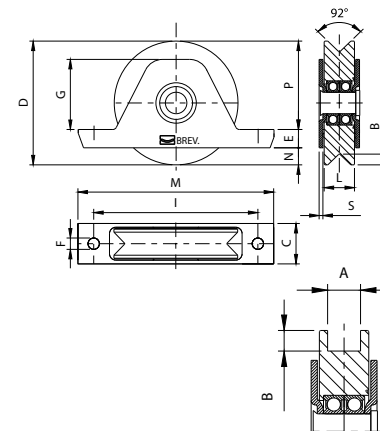

337 W

Ruota supporto interno gola semitonda
Wheel with internal plate, half-rounded groove
Galet avec platine interne, gorge demi-ronde
Schiebetorrolle mit Rundrille und Innenstützplatte
Rueda con soporte interior canal semicircular
Колесо с внутренним суппортом с полукруглым пазом

1 CUSCINETTO
1 BEARING



CODE	ART.	B	C	D	E	F	G	I	L	M	N	P	R	S	Portata ruota-Kg Capacity wheel-Kg		Box info		
															Pcs per pack	Kg			
11515020 001	337-80	7,5	32	Ø 78	14	Ø 9	38	110	20	135	14	50	8,5	3	Ø 15	Ø 15	180	6	4,40
11515025 001	337-80S	9,5	32	Ø 78	14	Ø 9	38	110	24	135	14	50	10,5	3	Ø 19	Ø 19	180	6	4,50
11515030 001	337-90	7,5	32	Ø 88	14,5	Ø 9	55,5	130	21	155	8,5	65	8,5	3	Ø 15	Ø 15	190	6	6,30
11515035 001	337-90S	9,5	32	Ø 88	14,5	Ø 9	55,5	130	24	155	8,5	65	10,5	3	Ø 19	Ø 19	190	6	6,40
11515040 001	337-100	7,5	32	Ø 98	14,5	Ø 9	55,5	130	21	155	13,5	70	8,5	3	Ø 15	Ø 15	200	6	7,60
11515045 001	337-100S	9,5	32	Ø 98	14,5	Ø 9	55,5	130	24	155	13,5	70	10,5	3	Ø 19	Ø 19	200	6	7,80
11515050 001	337-120	9,5	37	Ø 117	15	Ø 9	65	155	25	185	16,5	85,5	10,5	3	Ø 19	Ø 19	220	2	4,20
11515060 001	337-140	9,5	40	Ø 137	17	Ø 11	77	175	25	205	15	105	10,5	3	Ø 19	Ø 19	240	2	6,90

Finishing: Zincato / Galvanized

Categoria commerciale: 1M

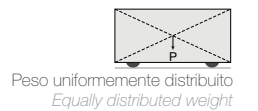
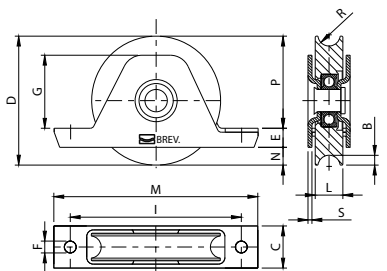

337i W

Ruota supporto interno gola semitonda
Wheel with internal plate, half-rounded groove
Galet avec platine interne, gorge demi-ronde
Schiebetorrolle mit Rundrille und Innenstützplatte
Rueda con soporte interior canal semiredondo
Колесо с внутренним суппортом с полукруглым пазом

1 CUSCINETTO
1 BEARING



CODE	ART.	B	C	D	E	F	G	I	L	M	N	P	R	S	Portata ruota-Kg Capacity wheel-Kg		Box info		
															267	289	Pcs per pack	Kg	
11515130	337i-90S	9,5	33	Ø88	14,5	Ø9	55,5	130	24	155	8,5	65	10,5	3	Ø19	Ø19	190	2	2,20
11515140	337i-100S	9,5	33	Ø98	14,5	Ø9	55,5	130	24	155	13,5	70	10,5	3	Ø19	Ø19	200	2	2,70
11515150	337i-120	9,5	38	Ø117	15	Ø9	65	155	25	185	16,5	85,5	10,5	3	Ø19	Ø19	220	2	4,20

Finishing: Inox / Stainless steel

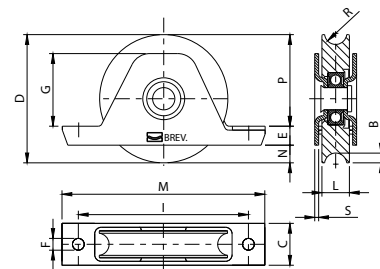

Categoria commerciale: 1M

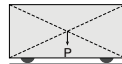

Peso uniformemente distribuito
Equally distributed weight

338i W

Ruota supporto interno gola semitonda a 2 cuscinetti
Wheel with internal plate, half-rounded groove and 2 bearings
Galet avec platine interne, gorge demi-ronde et 2 roulements
Schiebetorrolle mit Rundrille, Innenstützplatte und 2 Kugellagern
Rueda con soporte interior canal semiredondo con 2 rodamientos
Колесо с внутренним суппортом с полукруглым пазом с 2 подшипниками

2 CUSCINETTI
2 BEARINGS



CODE	ART.	B	C	D	E	F	G	I	L	M	N	P	R	S	Portata ruota-Kg Capacity wheel-Kg		Box info		
															267	289	Pcs per pack	Kg	
11515630	338i-90	8	33	Ø88	14,5	Ø9	55,5	130	24	155	9	64,5	10,5	3	Ø19	Ø19	300	2	2,50
11515640	338i-100	8	33	Ø98	14,5	Ø9	55,5	130	24	155	14	69,5	10,5	3	Ø19	Ø19	380	2	3,00
11515650	338i-120	9,5	38	Ø117	15	Ø9	65	155	28	185	16,5	85,5	10,5	3	Ø19	Ø19	400	2	4,80

Finishing: Inox / Stainless steel

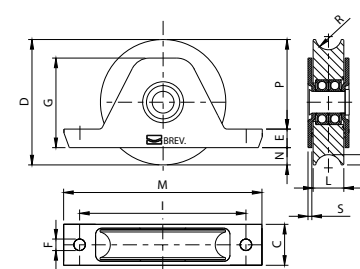

Categoria commerciale: 1M

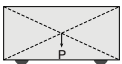

Peso uniformemente distribuito
Equally distributed weight

338 W

Ruota supporto interno gola semitonda
Wheel with internal plate, half-rounded groove
Galet avec platine interne, gorge demi-ronde
Schiebetorrolle mit Rundrille und Innenstützplatte
Rueda con soporte interior canal semiredondo
Колесо с внутренним суппортом с полукруглым пазом

2 CUSCINETTI
2 BEARINGS



CODE	ART.	B	C	D	E	F	G	I	L	M	N	P	R	S	Portata ruota-Kg Capacity wheel-Kg		Box info		
															267	289	Pcs per pack	Kg	
11515530 001	338-90	8	32	Ø88	14,5	Ø9	55,5	130	24	155	9	64,5	10,5	3	Ø19	Ø19	300	6	7,10
11515540 001	338-100	8	32	Ø98	14,5	Ø9	55,5	130	24	155	14	69,5	10,5	3	Ø19	Ø19	380	6	8,70
11515550 001	338-120	9,5	37	Ø117	15	Ø9	65	155	28	185	16,5	85,5	10,5	3	Ø19	Ø19	400	2	4,70
11515560 001	338-140	9,5	40	Ø137	17	Ø11	77	175	28	205	15	105	10,5	3	Ø19	Ø19	420	2	6,70
11515570 001	338-160	9,5	42	Ø157	20	Ø11	87	195	33	225	20,5	116,5	11,5	3	Ø19	Ø19	640	2	10,10
11515580 001	338-200	9,5	42	Ø197	22,5	Ø11	107,5	240	33	275	26,5	148	11,5	3	Ø19	Ø19	700	2	16,30

Finishing: Zincato / Galvanized

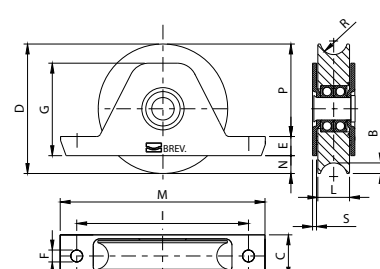

Categoria commerciale: 1M

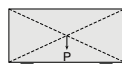

Peso uniformemente distribuito
Equally distributed weight

339 W

Ruote combinate gola U con ingrassatore
Grease gun twin wheels U groove
Galets combinés avec graisseur, gorge U
Verknüpfte Schiebetorrollen mit U-Rille und Schmiernippel
Ruedas combinadas canal U con engrasador
Комбинированные колеса с пазом U с масляной

2 CUSCINETTI
2 BEARINGS



CODE	ART.	A	B	D	N	R	Perno Wheel Pin	Portata ruota-Kg Capacity wheel-Kg	Box info	
									Pcs per pack	Kg
11515611 001	339U-120	21	10	Ø117	170	10,5	M18 x 80	1200	2	20,00
11515612 001	339U-160	21	10	Ø157	190	11,5	M18 x 80	1920	2	30,20

Finishing: Zincato / Galvanized

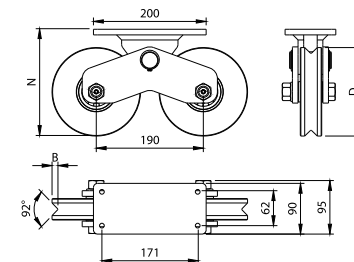

Categoria commerciale: 1M

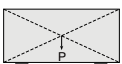

Peso uniformemente distribuito
Equally distributed weight

339 W

Ruote combinate gola V con ingrassatore

Grease gun twin wheels V groove
Galets combinés avec graisseur, gorge V
Verknüpfte Schiebetrollen mit V-Rille und Schmiernippel
Ruedas combinadas canal V con engrasador
Комбинированные колеса с пазом V с масляной

2 CUSCINETTI
2 BEARINGS



CODE	ART.	B	D	N	R	Perno Wheel Pin	Portata ruota-Kg Capacity wheel-Kg	Box info	
								Pcs per pack	Kg
11515621 001	339V-120	10	Ø117	170	10,5	M18 x 80	1200	2	20,00
11515622 001	339V-160	10,5	Ø157	190	11,5	M18 x 80	1920	2	30,20

Finishing: Zincato / Galvanized

Categoria commerciale: 1M

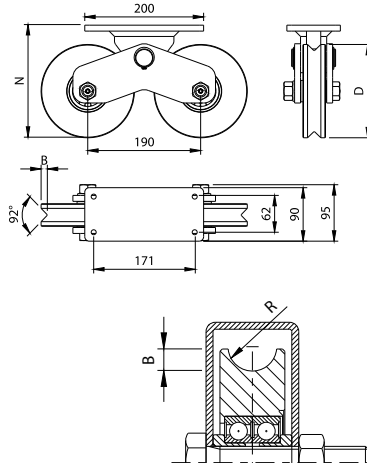

Peso uniformemente distribuito
Equally distributed weight

339 W

Ruote combinate gola semitonda con ingrassatore

Grease gun twin wheels half-rounded groove
Galets combinés avec graisseur, gorge demi-ronde
Verknüpfte Schiebetrollen mit Rundrille und Schmiernippel
Ruedas combinadas canal semirredondo con engrasador
Комбинированные колеса с полукруглым пазом с масляной

2 CUSCINETTI
2 BEARINGS



CODE	ART.	B	D	N	R	E	F	G	H	I	Perno Wheel Pin	Portata ruota-Kg Capacity wheel-Kg	Box info	
													Pcs per pack	Kg
11515641 001	339-120	9,5	Ø117	170	10,5	200	62	90	95	190	M18 x 80	1200	2	20,00
11515642 001	339-160	9,5	Ø157	190	11,5	200	62	90	95	190	M18 x 80	1920	2	30,20
19907301 001	339-250	9,5	Ø247	281	11,5	250	110	140	135	300	M24 x 120	3000	1	43,00

Finishing: Zincato / Galvanized

Categoria commerciale: 1M

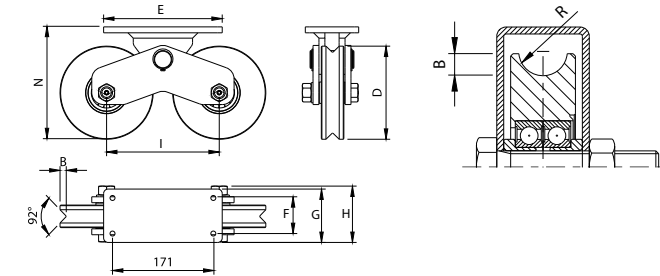

Peso uniformemente distribuito
Equally distributed weight

Mounting instructions art. 339V

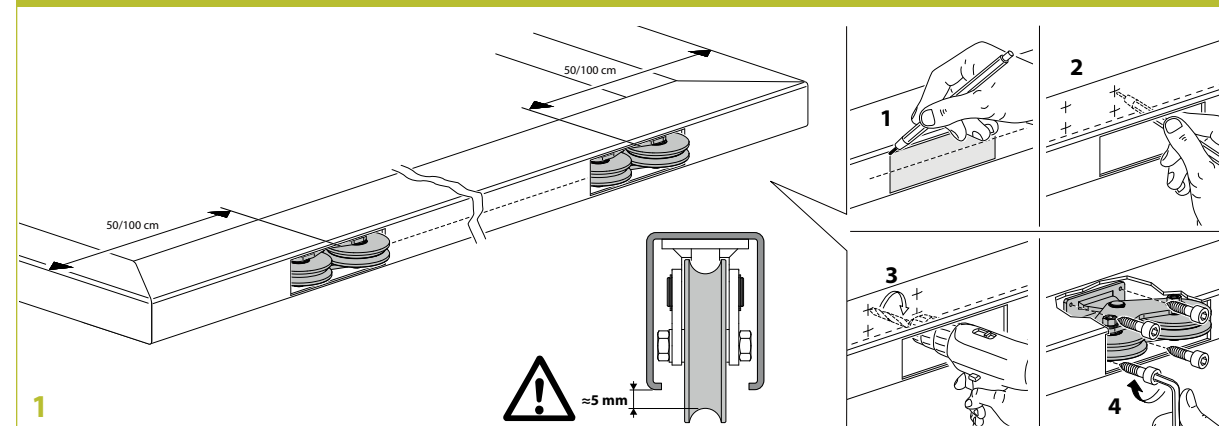

1

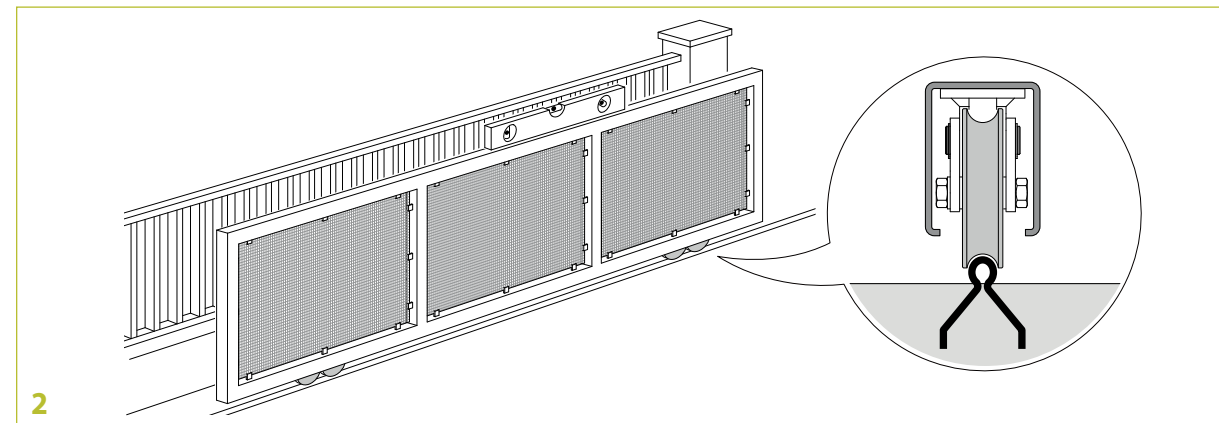

2

340 W

Ruota per fune gola semitonda a 1 cuscinetto

Wheel for rope, half-rounded groove and 1 bearing
Galet pour corde, gorge demi-ronde et 1 roulement
Rolle für seil, Rundrille und 1 Kugellager
Rueda para cables canal semirredondo con 1 rodamiento
Колесо для троса с полукруглым пазом с 1 подшипником

1 CUSCINETTO
1 BEARING



CODE	ART.	B	C	D	Fune Rope	L	Q	Portata ruota-Kg Capacity wheel-Kg	Box info	
									Pcs per pack	Kg
11516010 001	340-60	7	20	Ø 58	Ø 6	13	Ø 10,2	100	12	2,30
11516020 001	340-80	9	20	Ø 78	Ø 6	14	Ø 12,5	200	12	4,80
11516040 001	340-100	9	22	Ø 98	Ø 8	17	Ø 12,5	220	10	7,60
11516050 001	340-120	9	22	Ø 117	Ø 8	17	Ø 12,5	240	8	9,30

Finishing: Zincato / Galvanized

Categoria commerciale: 1M

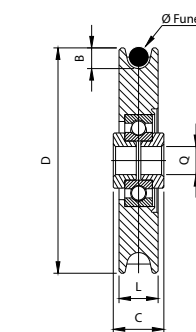

Peso uniformemente distribuito
Equally distributed weight

342 W

Ruota per fune in nylon gola semitonda a 1 cuscinetto

Nylon wheel for rope, half-rounded groove and 1 bearing
Galet pour corde en nylon, gorge demi-ronde et 1 roulement
Nylon-rolle für seil, Rundrille und 1 Kugellager
Rueda para cables de nylon canal semirredondo con 1 rodamiento
Колесо для нейлонового троса с полукруглым пазом с 1 подшипником

1 CUSCINETTO
1 BEARING



CODE	ART.	B	C	D	F	L	Q	Portata ruota-Kg Capacity wheel-Kg	Box info	
									Pcs per pack	Kg
11517020	342-80	7	22	Ø79	Ø6	18	12,2	50	12	1,80
11517030	342-90	7	22	Ø89	Ø6	18	12,2	60	10	1,80
11517040	342-100	7,5	22	Ø98	Ø6	18	12,2	70	10	1,90

Finishing: Nylon

Categoria commerciale: 1M

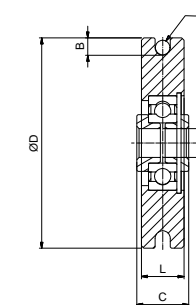

Peso uniformemente distribuito
Equally distributed weight

1 CUSCINETTO
1 BEARING



CERNIERE
HINGES

08



400

Cuscinetto a sfere assiale
torcito e cementato

Turned ball bearing
Roulement à billes tourné et scellé
Axial kugellager
Rodamiento de bolas axial torneado y cementado
Шариковый подшипник осевой обточенный и цементированный

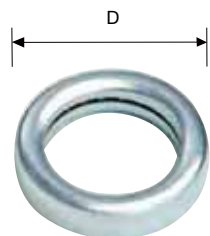

CODE	ART.	D	F	S	Box info	
					Pcs per pack	Kg
12400503 001	400-9	Ø15	Ø9	6	100	0,40
12400504 001	400-10	Ø17,5	Ø10	6	100	0,60
12400505 001	400-11	Ø19	Ø11	7,2	100	0,90
12400510 001	400-12	Ø20	Ø12	7,2	100	0,90
12400515 001	400-14	Ø22	Ø14	7,3	100	1,00
12400520 001	400-16,5	Ø27	Ø16,5	6,5	100	1,50
12400525 001	400-20	Ø32	Ø20	8,2	100	4,30

Finishing: Zincato / Galvanized

Categoria commerciale: 1E

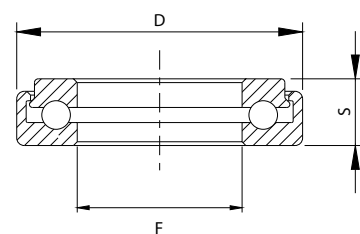

401Z

Rondella in acciaio Zincato

Galvanized and sintered steel washer
Rondelle en acier zingué
Gesinterter Stahlzwischenring
Arandela de acero galvanizado
Шайба из оцинкованной стали

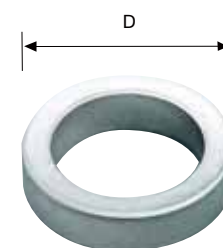

CODE	ART.	D	F	S	Box info	
					Pcs per pack	Kg
15400506 001	401Z-6	Ø9	Ø6	2	200	0,15
15400508 001	401Z-8	Ø12	Ø8	2,5	200	0,28
15400509 001	401Z-9	Ø13	Ø9	2,5	200	0,30
15400510 001	401Z-10	Ø15	Ø10	2,5	200	0,42
15400511 001	401Z-11	Ø15	Ø11	2,5	200	0,44
15400512 001	401Z-12	Ø18	Ø12	2,5	200	0,63
15400514 001	401Z-14	Ø19	Ø14	2,5	200	0,56

Finishing: Zincato / Galvanized

Categoria commerciale: 1E

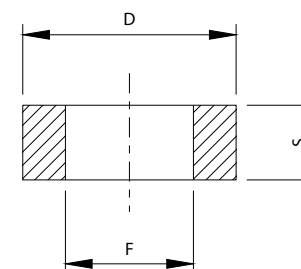

401S

Rondella in acciaio Zincato
e Sinterizzato

Galvanized and sintered steel washer
Rondelle en acier zingué et fritté
Gesinterter Stahlzwischenring
Arandela de acero galvanizado y sinterizado
Шайбы из оцинкованной стали с агломерацией

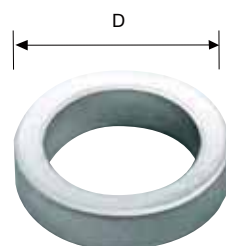

CODE	ART.	D	F	S	Box info	
					Pcs per pack	Kg
15400712 001	401S-12	Ø20	Ø12	7	50	0,50
15400714 001	401S-14	Ø22	Ø14	7	50	0,60
15400720 001	401S-20	Ø28	Ø20	7	50	0,70

Finishing: Zincato / Galvanized

Categoria commerciale: 1E

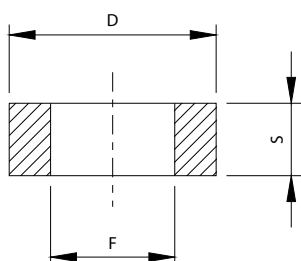

401i

Rondella in acciaio Inox

Stainless steel washer
Rondelle en acier Inox
Zwischenring aus Edelstahl
Arandela de acero inoxidable
Шайба из нержавеющей стали

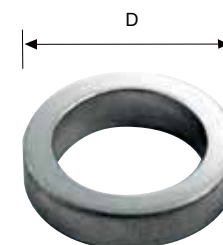

CODE	ART.	D	F	S	Box info	
					Pcs per pack	Kg
15400606	401i-6	Ø9	Ø6	2	200	0,15
15400608	401i-8	Ø12	Ø8	2,5	200	0,28
15400609	401i-9	Ø13	Ø9	2,5	200	0,30
15400610	401i-10	Ø15	Ø10	2,5	200	0,42
15400611	401i-11	Ø15	Ø11	2,5	200	0,44
15400612	401i-12	Ø18	Ø12	2,5	200	0,63
15400614	401i-14	Ø19	Ø14	2,5	200	0,56

Finishing: Inox / Stainless steel

Categoria commerciale: 2E

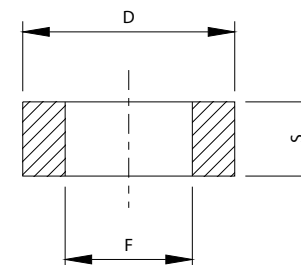



402

Cerniera a 2 ali con perno sfilabile
Hinge with 2 wings and extractable pivot
Paumelle avec 2 ailes et pivot à déboîter
Anschweißband 2-teilig mit lösem Zapfen
Perno de 2 palas con eje extraíble
Шарнир с 2 полками с вынимаемым штифтом



CODE	ART.	A	C	D	E	F	L	S	Portata - Kg Capacity - Kg	Box info	
										Pcs per pack	Kg
11604006	402-60	26	10	Ø5,7	13,5	4	58	2	50	40	1,60
11604008	402-80	38	12	Ø7,7	16,5	4	83	2,5	75	50	4,00
11604010	402-100	48	13	Ø8,7	17,5	4	104	2,5	100	50	5,70
11604012	402-120	57	15,3	Ø9,8	21	5	122	2,5	150	40	7,40
11604014	402-140	68	16	Ø10,7	21,5	5	144	2,5	200	40	9,50

Finishing: Non zincato / Not galvanized

Categoria commerciale: 1E

La portata è riferita ad una coppia di cerniere nel caso di peso uniformemente distribuito in un'anta con L=H.
Weight bearing capacity refers to a pair of hinges mounted on a gate with weight uniformly distributed on a leaf with proportions L=H.

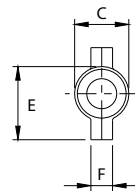
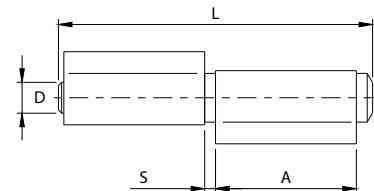

Peso uniformemente distribuito
Equally distributed weight
**PERNO ZINCATO
GALVANIZED PIN**

405

Cerniera pesante a 2 ali
con perno sfilabile
Heavy hinge with 2 wings and extractable pivot
Paumelle lourde avec 2 ailes et pivot à déboîter
Anschweißband 2-teilig schwere Ausführung mit lösem Zapfen
Perno pesado de 2 palas con eje extraíble
Тяжелый шарнир с 2 полками с вынимаемым штифтом



CODE	ART.	A	C	D	E	F	L	S	Portata - Kg Capacity - Kg	Box info	
										Pcs per pack	Kg
11604514	405-140	68	17,6	Ø11,7	25	5,6	145	2,5	250	20	5,80
11604517	405-170	83	17,6	Ø11,7	25	5,6	174	2,5	250	20	7,0
11604520	405-200	98	19,6	Ø13,6	27	5,6	205	2,5	350	14	7,30

Finishing: Non zincato / Not galvanized

Categoria commerciale: 1E

La portata è riferita ad una coppia di cerniere nel caso di peso uniformemente distribuito in un'anta con L=H.
Weight bearing capacity refers to a pair of hinges mounted on a gate with weight uniformly distributed on a leaf with proportions L=H.

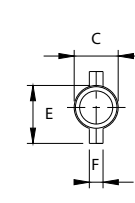
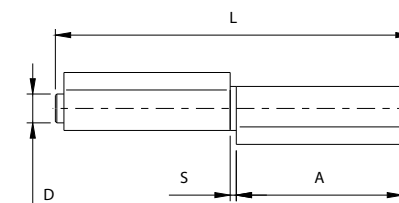

Peso uniformemente distribuito
Equally distributed weight
**PERNO ZINCATO
GALVANIZED PIN**

402Z

Cerniera a 2 ali con perno sfilabile
Hinge with 2 wings and extractable pivot
Paumelle avec 2 ailes et pivot à déboîter
Anschweißband 2-teilig mit lösem Zapfen
Perno de 2 palas con eje extraíble
Шарнир с 2 полками с вынимаемым штифтом



CODE	ART.	A	C	D	E	F	L	S	Portata - Kg Capacity - Kg	Box info	
										Pcs per pack	Kg
11604006 001	402Z-60	26	10	Ø5,7	13,5	4	58	2	50	40	1,60
11604008 001	402Z-80	38	12	Ø7,7	16,5	4	83	2,5	75	50	4,00
11604010 001	402Z-100	48	13	Ø8,7	17,5	4	104	2,5	100	50	5,70
11604012 001	402Z-120	57	15,3	Ø9,8	21	5	122	2,5	150	40	7,40
11604014 001	402Z-140	68	16	Ø10,7	21,5	5	144	2,5	200	40	9,50

Finishing: Zincato / Galvanized

Categoria commerciale: 1E

La portata è riferita ad una coppia di cerniere nel caso di peso uniformemente distribuito in un'anta con L=H.
Weight bearing capacity refers to a pair of hinges mounted on a gate with weight uniformly distributed on a leaf with proportions L=H.

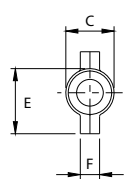
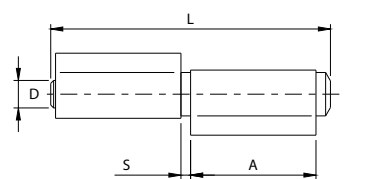

Peso uniformemente distribuito
Equally distributed weight

405Z

Cerniera pesante a 2 ali
con perno sfilabile
Heavy hinge with 2 wings and extractable pivot
Paumelle lourde avec 2 ailes et pivot à déboîter
Anschweißband 2-teilig schwere Ausführung mit lösem Zapfen
Perno pesado de 2 palas con eje extraíble
Тяжелый шарнир с 2 полками с вынимаемым штифтом



CODE	ART.	A	C	D	E	F	L	S	Portata - Kg Capacity - Kg	Box info	
										Pcs per pack	Kg
11604514 001	405Z-140	68	17,6	Ø11,7	25	5,6	145	2,5	250	20	5,80
11604517 001	405Z-170	83	17,6	Ø11,7	25	5,6	174	2,5	250	20	7,0
11604520 001	405Z-200	98	19,6	Ø13,6	27	5,6	205	2,5	350	14	7,30

Finishing: Zincato / Galvanized

Categoria commerciale: 1E

La portata è riferita ad una coppia di cerniere nel caso di peso uniformemente distribuito in un'anta con L=H.
Weight bearing capacity refers to a pair of hinges mounted on a gate with weight uniformly distributed on a leaf with proportions L=H.

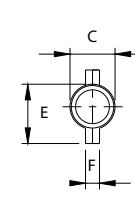
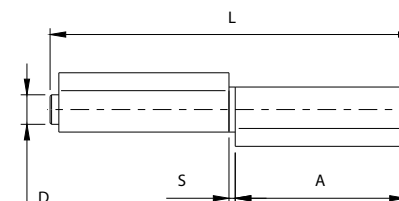

Peso uniformemente distribuito
Equally distributed weight

402i

Cerniera a 2 ali con perno sfilabile
Hinge with 2 wings and extractable pivot
Paumelle avec 2 ailes et pivot à déboîter
Anschweißband 2-teilig mit lösem Zapfen
Perno de 2 palas con eje extraíble
Шарнир с 2 полками с вынимаемым штифтом



CODE	ART.	A	C	D	E	F	L	S	Portata - Kg Capacity - Kg	Box info	
										Pcs per pack	Kg
11604206	402i-60	26	10	Ø5,7	13,5	4	58	2	50	20	0,80
11604208	402i-80	38	12	Ø7,7	16,5	4	83	2,5	75	20	1,60
11604210	402i-100	48	13	Ø8,7	17,5	4	104	2,5	100	20	2,30
11604212	402i-120	57	15,3	Ø9,8	21	5	122	2,5	150	20	3,80
11604214	402i-140	68	16	Ø10,7	21,5	5	144	2,5	200	20	4,40

Finishing: Inox / Stainless steel

Categoria commerciale: 2E

La portata è riferita ad una coppia di cerniere nel caso di peso uniformemente distribuito in un'anta con L=H.
Weight bearing capacity refers to a pair of hinges mounted on a gate with weight uniformly distributed on a leaf with proportions L=H.

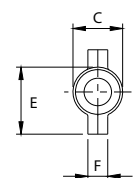
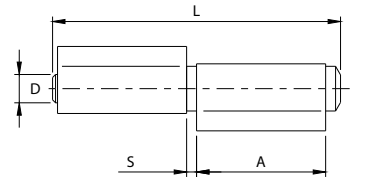

Peso uniformemente distribuito
Equally distributed weight

405i

Cerniera pesante a 2 ali
con perno sfilabile
Heavy hinge with 2 wings and extractable pivot
Paumelle lourde avec 2 ailes et pivot à déboîter
Anschweißband 2-teilig schwere Ausführung mit lösem Zapfen
Perno pesado de 2 palas con eje extraíble
Тяжелый шарнир с 2 полками с вынимаемым штифтом



CODE	ART.	A	C	D	E	F	L	S	Portata - Kg Capacity - Kg	Box info	
										Pcs per pack	Kg
11604614	405i-140	68	17,6	Ø11,7	25	5,6	145	2,5	250	20	6,20
11604617	405i-170	83	17,6	Ø11,7	25	5,6	174	2,5	250	20	7,40
11604620	405i-200	98	19,6	Ø13,6	27	5,6	205	2,5	350	16	8,70

Finishing: Inox / Stainless steel

Categoria commerciale: 1E

La portata è riferita ad una coppia di cerniere nel caso di peso uniformemente distribuito in un'anta con L=H.
Weight bearing capacity refers to a pair of hinges mounted on a gate with weight uniformly distributed on a leaf with proportions L=H.

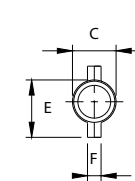
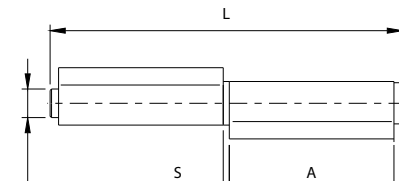

Peso uniformemente distribuito
Equally distributed weight





410

Cerniera a 3 ali con perno sfilabile
Hinge with 3 wings and extractable pivot
Paumelle avec 3 ailes et pivot à déboîter
Anschweißband 3-teilig mit lösem Zapfen
Perno de 3 palas con eje extraíble
Шарнир с 3 полками с вынимаемым штифтом



CODE	ART.	A	B	C	D	E	F	L	S	Portata - Kg Capacity - Kg	Box info	
											Pcs per pack	Kg
11605008	410-80	18	38	12	Ø7,7	16,5	4	83	2,5	75	50	3,90
11605010	410-100	23,5	48	13	Ø8,7	17,5	4	104	2,5	100	50	5,70
11605012	410-120	27	57	15	Ø9,8	21	5	122	2,5	150	40	7,30
11605014	410-140	33	68	16	Ø10,7	21,5	5	144	2,5	200	40	9,60

Finishing: Non zincato / Not galvanized

Categoria commerciale: 1E

La portata è riferita ad una coppia di cerniere nel caso di peso uniformemente distribuito in un'anta con L=H.
Weight bearing capacity refers to a pair of hinges mounted on a gate with weight uniformly distributed on a leaf with proportions L=H.

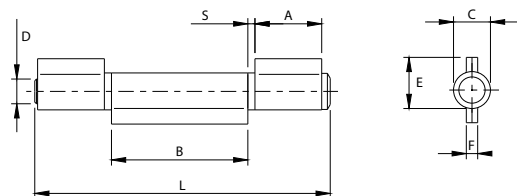

Peso uniformemente distribuito
Equally distributed weight

PERNO ZINCATO
GALVANIZED PIN

410Z

Cerniera a 3 ali con perno sfilabile
Hinge with 3 wings and extractable pivot
Paumelle avec 3 ailes et pivot à déboîter
Anschweißband 3-teilig mit lösem Zapfen
Perno de 3 palas con eje extraíble
Шарнир с 3 полками с вынимаемым штифтом



CODE	ART.	A	B	C	D	E	F	L	S	Portata - Kg Capacity - Kg	Box info	
											Pcs per pack	Kg
11605008 001	410Z-80	18	38	12	Ø7,7	16,5	4	83	2,5	75	50	3,90
11605010 001	410Z-100	23,5	48	13	Ø8,7	17,5	4	104	2,5	100	50	5,70
11605012 001	410Z-120	27	57	15	Ø9,8	21	5	122	2,5	150	40	7,30
11605014 001	410Z-140	33	68	16	Ø10,7	21,5	5	144	2,5	200	40	9,60

Finishing: Zincato / Galvanized

Categoria commerciale: 1E

La portata è riferita ad una coppia di cerniere nel caso di peso uniformemente distribuito in un'anta con L=H.
Weight bearing capacity refers to a pair of hinges mounted on a gate with weight uniformly distributed on a leaf with proportions L=H.

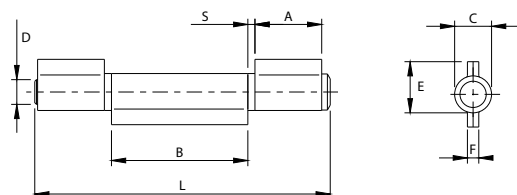

Peso uniformemente distribuito
Equally distributed weight

410i

Cerniera a 3 ali con perno sfilabile
Hinge with 3 wings and extractable pivot
Paumelle avec 3 ailes et pivot à déboîter
Anschweißband 3-teilig mit lösem Zapfen
Perno de 3 palas con eje extraíble
Шарнир с 3 полками с вынимаемым штифтом



CODE	ART.	A	B	C	D	E	F	L	S	Portata - Kg Capacity - Kg	Box info	
											Pcs per pack	Kg
11605208	410i-80	18	38	12	Ø7,7	16,5	4	83	2,5	75	20	1,70
11605210	410i-100	23,5	48	13	Ø8,7	17,5	4	104	2,5	100	20	2,40
11605212	410i-120	27	57	15	Ø9,8	21	5	122	2,5	150	20	3,80
11605214	410i-140	33	68	16	Ø10,7	21,5	5	144	2,5	200	20	4,90

Finishing: Inox / Stainless steel

Categoria commerciale: 2E

La portata è riferita ad una coppia di cerniere nel caso di peso uniformemente distribuito in un'anta con L=H.
Weight bearing capacity refers to a pair of hinges mounted on a gate with weight uniformly distributed on a leaf with proportions L=H.

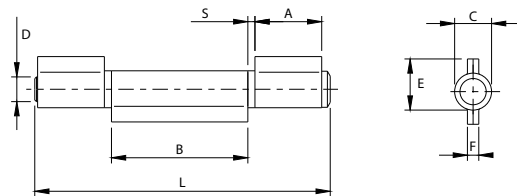

Peso uniformemente distribuito
Equally distributed weight

411 Tris

Cerniera a 3 ali antiscasso con perno e tappi in acciaio inox
Anti-theft 3 wings hinge with s/s pivot and plugs
Paumelle antivol à 3 ailes avec pivot et bouchons en inox
Einbruchssicheres Anschweißband 3-teilig mit Zapfen und Pfropfen aus Edelstahl
Perno de 3 palas antifracción con eje y tapones de acero inoxidable
Шарнир с 3 полками с защитой от взлома со штифтом и пробками из нержавеющей стали



CODE	ART.	Portata - Kg Capacity - Kg	Box info	
			Pcs per pack	Kg
11607514	411-170	400	10	5,50

Finishing: Non zincato / Not galvanized

Categoria commerciale: 1E

La portata è riferita ad una coppia di cerniere nel caso di peso uniformemente distribuito in un'anta con L=H.
Weight bearing capacity refers to a pair of hinges mounted on a gate with weight uniformly distributed on a leaf with proportions L=H.

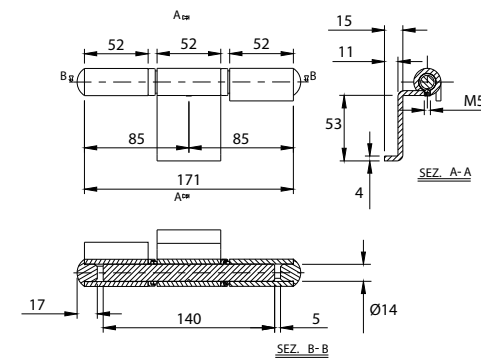

Peso uniformemente distribuito
Equally distributed weight

PERNO E TAPPI INOX
STAINLESS STEEL PIN AND CAPS

Mounting instructions art. 411 Tris

1. Preparation of the hole in the gate leaf. The hole diameter should be A 5-10%H.

2. Insertion of the stainless steel pin and cap into the hole.

3. Tightening of the cap to secure the hinge.



415

Cerniera pesante a 3 ali
con perno sfilabile

Heavy hinge with 3 wings and extractable pivot
Paumelle lourde avec 3 ailes et pivot à déboîter
Anschweißband 3-teilig schwere Ausführung mit loseem Zapfen
Perno pesado de 3 palas con eje extraíble
Тяжелый шарнир с 3 полками с вынимаемым штифтом



CODE	ART.	A	B	C	D	E	F	L	S	Portata - Kg Capacity - Kg	Box info	
											Pcs per pack	Kg
11605514	415-140	36	62	17,6	Ø11,7	25	5,6	145	2,5	250	20	5,90
11605517	415-170	44	75	17,6	Ø11,7	25	5,6	174	2,5	250	20	7,0
11605520	415-200	52	89	19,6	Ø13,6	27	5,6	205	2,5	300	20	8,20

Finishing: Non zincato / Not galvanized

Categoria commerciale: 1E

La portata è riferita ad una coppia di cerniere nel caso di peso uniformemente distribuito in un'anta con L=H.
Weight bearing capacity refers to a pair of hinges mounted on a gate with weight uniformly distributed on a leaf with proportions L=H.

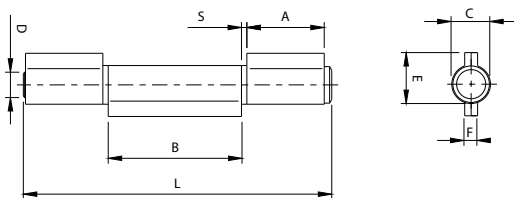

Peso uniformemente distribuito
Equally distributed weight

**PERNO ZINCATO
GALVANIZED PIN**

415Z

Cerniera pesante a 3 ali
con perno sfilabile

Heavy hinge with 3 wings and extractable pivot
Paumelle lourde avec 3 ailes et pivot à déboîter
Anschweißband 3-teilig schwere Ausführung mit loseem Zapfen
Perno pesado de 3 palas con eje extraíble
Тяжелый шарнир с 3 полками с вынимаемым штифтом



CODE	ART.	A	B	C	D	E	F	L	S	Portata - Kg Capacity - Kg	Box info	
											Pcs per pack	Kg
11605514 001	415Z-140	36	62	17,6	Ø11,7	25	5,6	145	2,5	250	20	5,90
11605517 001	415Z-170	44	75	17,6	Ø11,7	25	5,6	174	2,5	250	20	7,0
11605520 001	415Z-200	52	89	19,6	Ø13,6	27	5,6	205	2,5	300	16	8,20

Finishing: Zincato / Galvanized

Categoria commerciale: 1E

La portata è riferita ad una coppia di cerniere nel caso di peso uniformemente distribuito in un'anta con L=H.
Weight bearing capacity refers to a pair of hinges mounted on a gate with weight uniformly distributed on a leaf with proportions L=H.

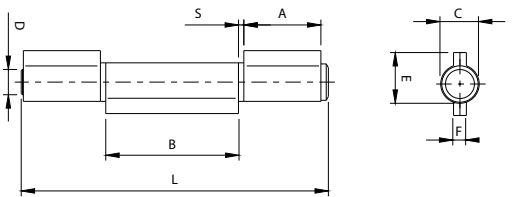

Peso uniformemente distribuito
Equally distributed weight

415i

Cerniera pesante a 3 ali
con perno sfilabile

Heavy hinge with 3 wings and extractable pivot
Paumelle lourde avec 3 ailes et pivot à déboîter
Anschweißband 3-teilig schwere Ausführung mit loseem Zapfen
Perno pesado de 3 palas con eje extraíble
Тяжелый шарнир с 3 полками с вынимаемым штифтом



CODE	ART.	A	B	C	D	E	F	L	S	Portata - Kg Capacity - Kg	Box info	
											Pcs per pack	Kg
11605614	415i-140	36	62	17,6	Ø11,7	25	5,6	145	2,5	250	10	3,10
11605617	415i-170	44	75	17,6	Ø11,7	25	5,6	174	2,5	250	20	7,50
11605620	415i-200	52	89	19,6	Ø13,6	27	5,6	205	2,5	300	16	8,60

Finishing: Inox / Stainless steel

Categoria commerciale: 2E

La portata è riferita ad una coppia di cerniere nel caso di peso uniformemente distribuito in un'anta con L=H.
Weight bearing capacity refers to a pair of hinges mounted on a gate with weight uniformly distributed on a leaf with proportions L=H.

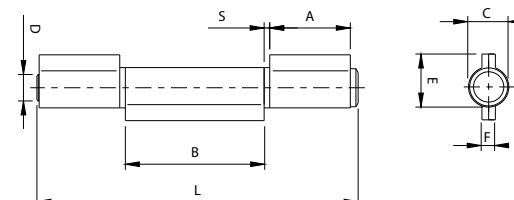

Peso uniformemente distribuito
Equally distributed weight



420

Cerniera a 2 ali con tappo saldato

Plug welded hinge with 2 wings
Paumelle à 2 ailes avec bouchon soudé
Anschweißband 2-teilig mit Anschweißpfropfen
Perno de 2 palas con tapón soldado
Шарнир с 2 полками с привариваемой пробкой

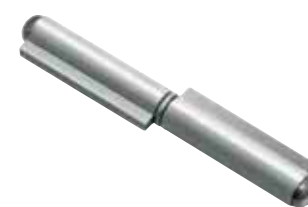

CODE	ART.	A	C	D	E	F	L	S	Portata - Kg Capacity - Kg	Box info	
										Pcs per pack	Kg
11606006	420-60	26	10	Ø5,8	13,5	4	64	1,7	50	40	1,30
11606008	420-80	38	12	Ø7,8	16,5	4	89,5	2,5	75	50	3,20
11606010	420-100	48	13	Ø8,7	17,5	4	110	2,5	100	50	4,40
11606012	420-120	57	15,3	Ø9,8	21	5	130	2,5	150	50	7,0
11606014	420-140	68	16	Ø10,8	21,5	5	152	3	200	50	9,0

Finishing: Non zincato / Not galvanized

Categoria commerciale: 1E

La portata è riferita ad una coppia di cerniere nel caso di peso uniformemente distribuito in un'anta con L=H.
Weight bearing capacity refers to a pair of hinges mounted on a gate with weight uniformly distributed on a leaf with proportions L=H.

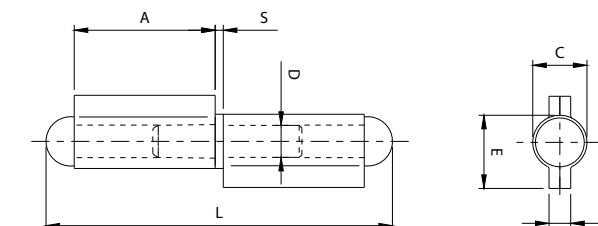

Peso uniformemente distribuito
Equally distributed weight

425

Cerniera pesante a 2 ali
con tappo saldato

Heavy plug welded hinge with 2 wings
Paumelle lourde à 2 ailes avec bouchon soudé
Anschweißband 2-teilig schwere Ausführung mit Pfropfen
Perno pesado de 2 palas con tapón soldado
Тяжелый шарнир с 2 полками с привариваемой пробкой



CODE	ART.	A	C	D	E	F	L	S	Portata - Kg Capacity - Kg	Box info	
										Pcs per pack	Kg
11606514	425-140	68	17,6	Ø11,8	25	5,6	154	3	250	20	4,50
11606517	425-170	83	17,6	Ø11,8	25	5,6	184,5	3	250	20	5,20
11606520	425-200	98	19,6	Ø13,8	27	5,6	217,5	3,5	350	20	7,80

Finishing: Non zincato / Not galvanized

Categoria commerciale: 1E

La portata è riferita ad una coppia di cerniere nel caso di peso uniformemente distribuito in un'anta con L=H.
Weight bearing capacity refers to a pair of hinges mounted on a gate with weight uniformly distributed on a leaf with proportions L=H.

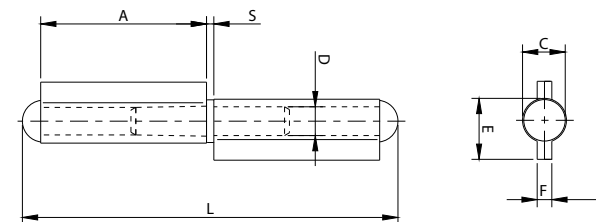

Peso uniformemente distribuito
Equally distributed weight



425 PS

Cerniera 2 ali pesante smontata
perno e tappi zincati

Heavy hinge with 2 wings and disassembled
galvanized pivot and plugs
Paumelle lourde à 2 ailes avec pivot et bouchons
zingués et démontés
Anschweißband 2-teilig schwere Ausführung mit
verzinkter ausgebauter Zapfen und Pfropfen
Perno de 2 palas pesado desmontado eje y
taponés galvanizados
Тяжелый демонтируемый шарнир с 2 полками
со штифтом и оцинкованными пробками



CODE	ART.	A	C	D	E	F	L	S	Portata - Kg Capacity - Kg	Box info	
										Pcs per pack	Kg
11606614	425PS-140	68	17,6	Ø11,8	25	5,6	154	3	250	50	11,60
11606617	425PS-170	83	17,6	Ø11,8	25	5,6	184,5	3	250	50	13,50

Finishing: Non zincato / Not galvanized

La portata è riferita ad una coppia di cerniere nel caso di peso uniformemente distribuito in un'anta con L=H.
Weight bearing capacity refers to a pair of hinges mounted on a gate with weight uniformly distributed on a leaf with proportions L=H.

Categoria commerciale: 1E

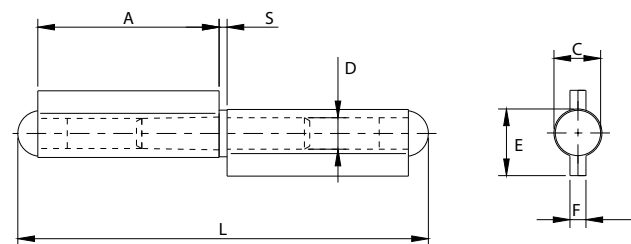

Peso uniformemente distribuito
Equally distributed weight

PERNO E TAPPI ZINCATI
GALVANIZED PIN AND CAPS

430 DX

Cerniera a 2 ali lunghe
con tappo saldato

Plug welded hinge with 2 long wings
Paumelle à bouchon soudé avec 2 ailes longues
Anschweißband 2-teilig mit Anschweißpfropfen
Perno de 2 palas largas con tapón soldado
Шарнир с 2 длинными полками с привариваемой пробкой



CODE	ART.	A	C	D	E	G	L	M	S	Portata - Kg Capacity - Kg	Box info	
											Pcs per pack	Kg
11607006	430DX-60	28	13,3	Ø8,3	33	2,5	70	52,7	2,5	100	20	3,30
11607008	430DX-80	38	15,4	Ø9	41	3	92	66,6	2,5	100	20	3,10
11607010	430DX-100	48	16,3	Ø9,8	43	3	112	69,7	2,5	150	20	4,0
11607012	430DX-120	57	17,5	Ø11,3	46	3	132	74,5	3	250	20	5,30
11607014	430DX-140	67	19,2	Ø11,8	50	3,5	156	80,8	4	250	10	4,0
11607017	430DX-170	84	21,3	Ø13	60	4	190	98,7	4	300	10	6,20
11607020	430DX-200	97	22,3	Ø13,9	71,2	4	216	122	4	350	10	8,40

Finishing: Non zincato / Not galvanized

La portata è riferita ad una coppia di cerniere nel caso di peso uniformemente distribuito in un'anta con L=H.
Weight bearing capacity refers to a pair of hinges mounted on a gate with weight uniformly distributed on a leaf with proportions L=H.

Categoria commerciale: 1E

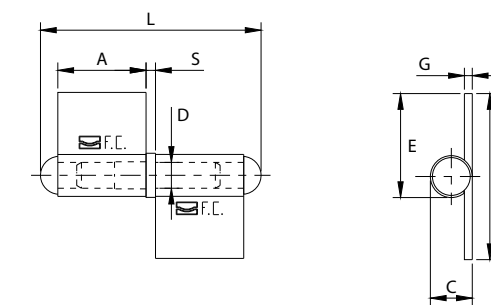

Peso uniformemente distribuito
Equally distributed weight

Mounting instructions art. 425 PS

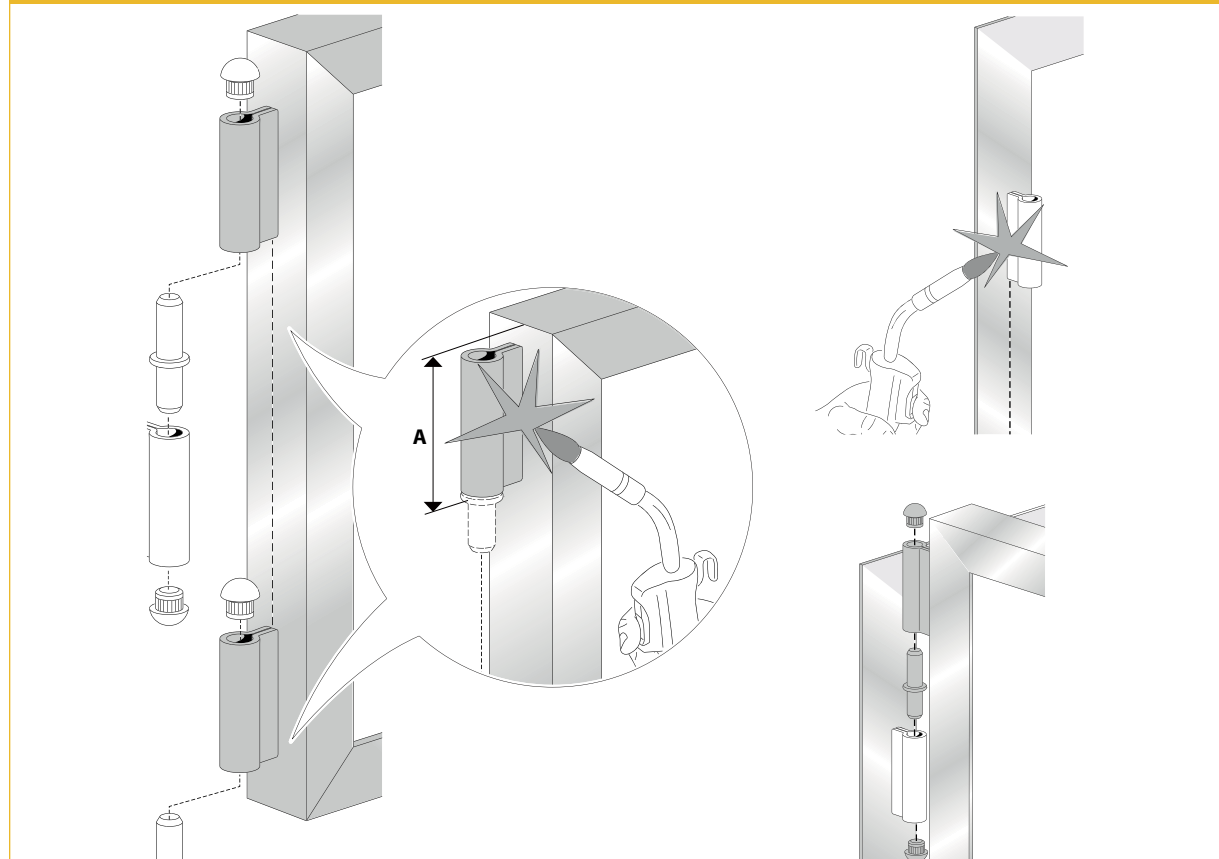

430 SX

Cerniera a 2 ali lunghe
con tappo saldato

Plug welded hinge with 2 long wings
Paumelle à bouchon soudé avec 2 ailes longues
Anschweißband 2-teilig mit Anschweißpfropfen
Perno de 2 palas largas con tapón soldado
Шарнир с 2 длинными полками с привариваемой пробкой



CODE	ART.	A	C	D	E	G	L	M	S	Portata - Kg Capacity - Kg	Box info	
											Pcs per pack	Kg
11607106	430SX-60	28	13,3	Ø8,3	33	2,5	70	52,7	2,5	100	20	3,30
11607108	430SX-80	38	15,4	Ø9	41	3	92	66,6	2,5	100	20	3,10
11607110	430SX-100	48	16,3	Ø9,8	43	3	112	69,7	2,5	150	20	4,0
11607112	430SX-120	57	17,5	Ø11,3	46	3	132	74,5	3	250	20	5,30
11607114	430SX-140	67	19,2	Ø11,8	50	3,5	156	80,8	4	250	10	4,0
11607117	430SX-170	84	21,3	Ø13	60	4	190	98,7	4	300	10	6,10
11607120	430SX-200	97	22,3	Ø13,9	71,2	4	216	122	4	350	10	8,40

Finishing: Non zincato / Not galvanized

La portata è riferita ad una coppia di cerniere nel caso di peso uniformemente distribuito in un'anta con L=H.
Weight bearing capacity refers to a pair of hinges mounted on a gate with weight uniformly distributed on a leaf with proportions L=H.

Categoria commerciale: 1E

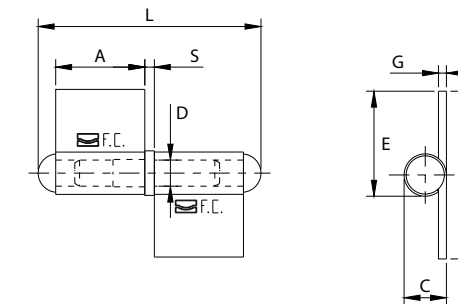

Peso uniformemente distribuito
Equally distributed weight



440

Cerniera a 2 ali aperte
perno sfilabile con rondella
Big hinge 2 open wings extractable pivot with washer
Paumelle grande 2 ailes ouvertes pivot à déboîter avec rondelle
Winkelband mit 2 offenen Flügeln schwere Ausführung
loser Zapfen mit Unterlegscheibe
Perno grande de 2 palas abiertas eje extraíble con arandela
Большой шарнир с 2 открытыми полками с
вынимаемым штифтом с шайбой



CODE	ART.	Portata - Kg Capacity - Kg	Box info	
			Pcs per pack	Kg
11607509	440-90	800	10	5,40

Finishing: Non zincato / Not galvanized

La portata è riferita ad una coppia di cerniere nel caso di peso uniformemente distribuito in un'anta con L=H.
Weight bearing capacity refers to a pair of hinges mounted on a gate with weight uniformly distributed on a leaf with proportions L=H.

Categoria commerciale: 1E

ENTRATA OLIO
OIL ENTRANCE

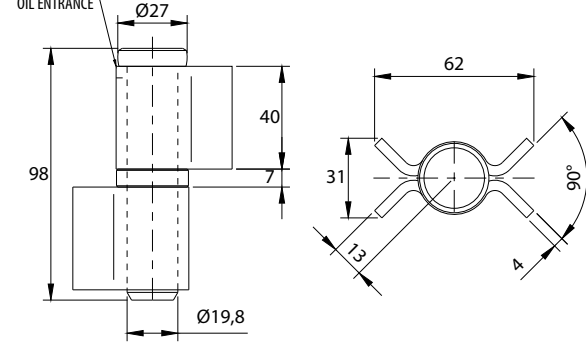

Peso uniformemente distribuito
Equally distributed weight

PERNO ZINCATO
GALVANIZED PIN

431

Cerniera 2 ali piana con perno sfilabile
Flat hinge with 2 wings and extractable pivot
Paumelle plate à 2 ailes avec pivot à déboîter
Flachband 2-teilig mit loseem Zapfen
Perno de 2 palas chatas con eje extraíble
Плоский шарнир с 2 полками с вынимаемым
штифтом



CODE	ART.	A	C	D	E	G	L	M	S	Portata - Kg Capacity - Kg	Box info	
											Pcs per pack	Kg
11607308	431-80	40	12	Ø 8	23	2	82	34	2	100	50	4,70
11607338	431-80-Sp3	38	14	Ø 8	25	3	78	36	2	100	50	6,20
11607310	431-100	48	16	Ø 10	26	3	98	36	2	150	50	9,20
11607311	431-110	52	18	Ø 10	29	4	107	40	3	150	40	10,8
11607312	431-120	58	20	Ø 12	33	4	119	46	3	250	30	17,7

Finishing: Non zincato / Not galvanized

La portata è riferita ad una coppia di cerniere nel caso di peso uniformemente distribuito in un'anta con L=H.
Weight bearing capacity refers to a pair of hinges mounted on a gate with weight uniformly distributed on a leaf with proportions L=H.

Categoria commerciale: 1E

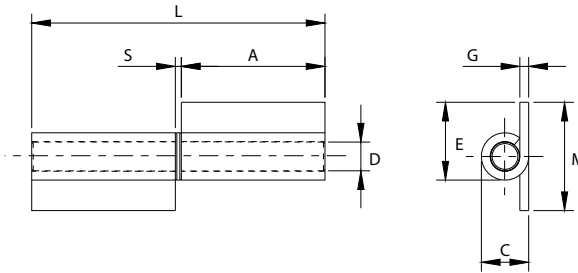

Peso uniformemente distribuito
Equally distributed weight

440i

Cerniera a 2 ali aperte
perno sfilabile con rondella in ottone
Big hinge 2 open wings extractable pivot with brass washer
Paumelle grande 2 ailes ouvertes pivot à déboîter avec
rondelle en laiton
Winkelband mit 2 offenen Flügeln schwere Ausführung
loser Zapfen mit Unterlegscheibe aus Messing
Perno grande de 2 palas abiertas eje extraíble con
arandela de latón
Большой шарнир с 2 открытыми полками с
вынимаемым штифтом с латунной шайбой



CODE	ART.	Portata - Kg Capacity - Kg	Box info	
			Pcs per pack	Kg
11607709	440i-90	800	4	2,20

Finishing: Inox / Stainless steel

La portata è riferita ad una coppia di cerniere nel caso di peso uniformemente distribuito in un'anta con L=H.
Weight bearing capacity refers to a pair of hinges mounted on a gate with weight uniformly distributed on a leaf with proportions L=H.

Categoria commerciale: 2E

ENTRATA OLIO
OIL ENTRANCE

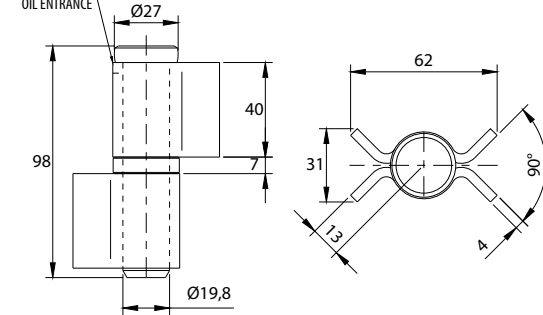

Peso uniformemente distribuito
Equally distributed weight

Mounting instructions art. 440

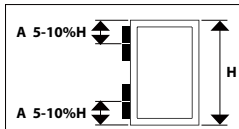
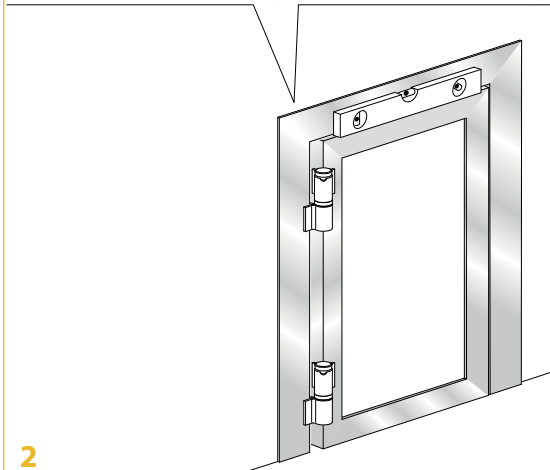
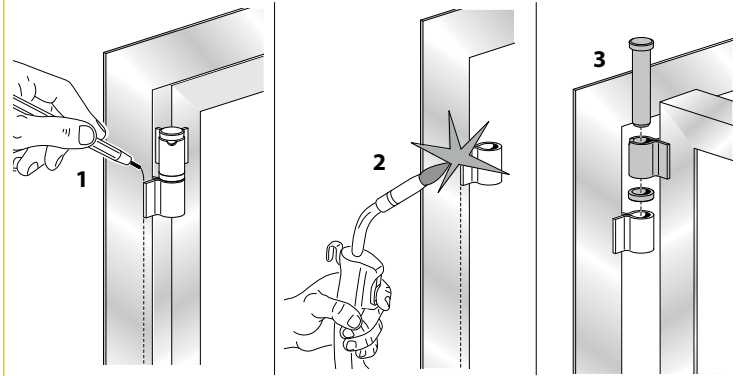
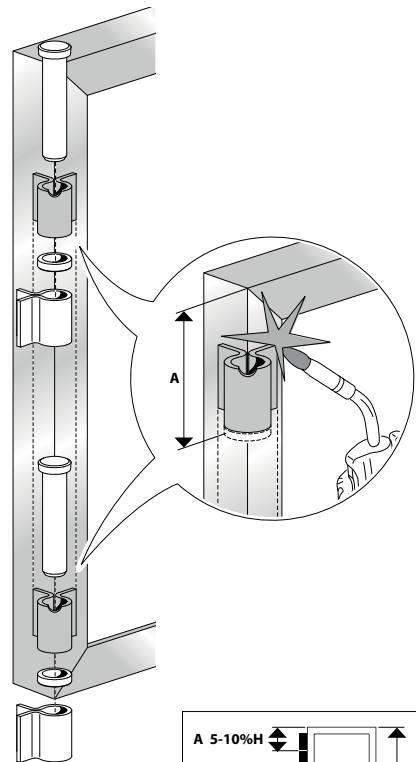

445

Cerniera a 2 ali aperte perno sfilabile
con cuscinetto
Big hinge 2 open wings extractable pivot with bearing
Paumelle grande 2 ailes ouvertes avec pivot à déboîter
et roulement
Winkelband 2-teilig schwere Ausführung loser Zapfen
mit Kugellager
Perno grande de 2 palas abiertas eje extraíble con rodamiento
Большой шарнир с 2 открытыми полками с
вынимаемым штифтом с подшипником



CODE	ART.	Portata - Kg Capacity - Kg	Box info	
			Pcs per pack	Kg
11608009	445-90	800	10	5,40

Finishing: Non zincato / Not galvanized

La portata è riferita ad una coppia di cerniere nel caso di peso uniformemente distribuito in un'anta con L=H.
Weight bearing capacity refers to a pair of hinges mounted on a gate with weight uniformly distributed on a leaf with proportions L=H.

Categoria commerciale: 1E

ENTRATA OLIO
OIL ENTRANCE

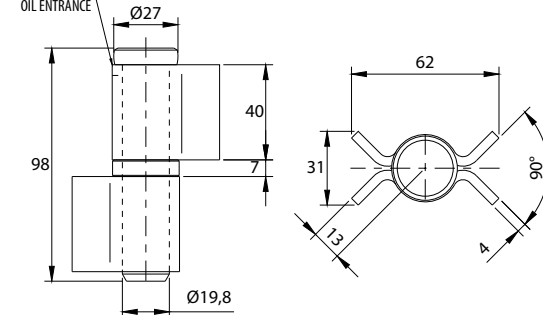

Peso uniformemente distribuito
Equally distributed weight

PERNO ZINCATO
GALVANIZED PIN



450

Cerniera a 2 ali chiuse perno sfilabile con rondella

Big hinge 2 closed wings extractable pivot with washer
Paumelle grande 2 ailes fermées pivot à déboîter avec rondelle
Winkelband mit 2 geschlossenen Flügeln schwere Ausführung loser Zapfen mit Unterlegscheibe
Perno grande de 2 palas cerradas eje extraíble con arandela
Большой шарнир с 2 закрытыми полками с вынимаемым штифтом с шайбой



CODE	ART.	Portata - Kg Capacity - Kg	Box info	
			Pcs per pack	Kg
11608509	450-90	400	10	5,80

Finishing: Non zincato / Not galvanized

La portata è riferita ad una coppia di cerniere nel caso di peso uniformemente distribuito in un'anta con L=H.
Weight bearing capacity refers to a pair of hinges mounted on a gate with weight uniformly distributed on a leaf with proportions L=H.

Categoria commerciale: 1E

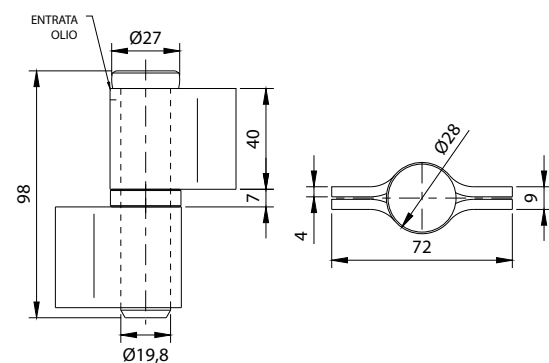

Peso uniformemente distribuito
Equally distributed weight

**PERNO ZINCATO
GALVANIZED PIN**

450i

Cerniera a 2 ali aperte perno sfilabile con rondella in ottone

Big hinge 2 open wings extractable pivot with brass washer
Paumelle grande 2 ailes ouvertes pivot à déboîter avec rondelle en laiton
Winkelband mit 2 offenen Flügeln schwere Ausführung loser Zapfen mit Unterlegscheibe aus Messing
Perno grande de 2 palas eje extraíble con arandela de latón
Большой шарнир с 2 полками с вынимаемым штифтом с латунной шайбой



CODE	ART.	Portata - Kg Capacity - Kg	Box info	
			Pcs per pack	Kg
11608609	450i-90	400	4	2,20

Finishing: Inox / Stainless steel

La portata è riferita ad una coppia di cerniere nel caso di peso uniformemente distribuito in un'anta con L=H.
Weight bearing capacity refers to a pair of hinges mounted on a gate with weight uniformly distributed on a leaf with proportions L=H.

Categoria commerciale: 2E

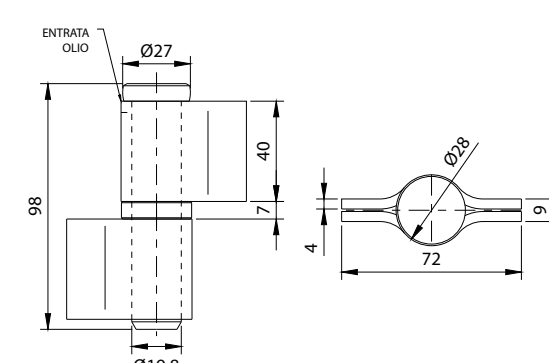

Peso uniformemente distribuito
Equally distributed weight

Mounting instructions art. 450

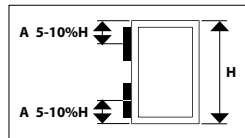
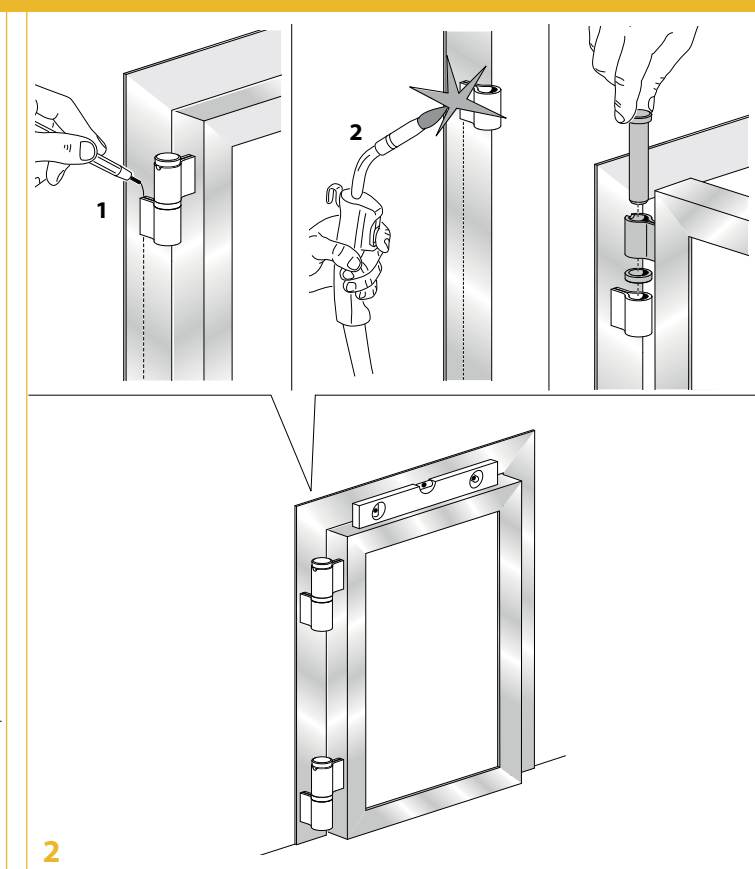
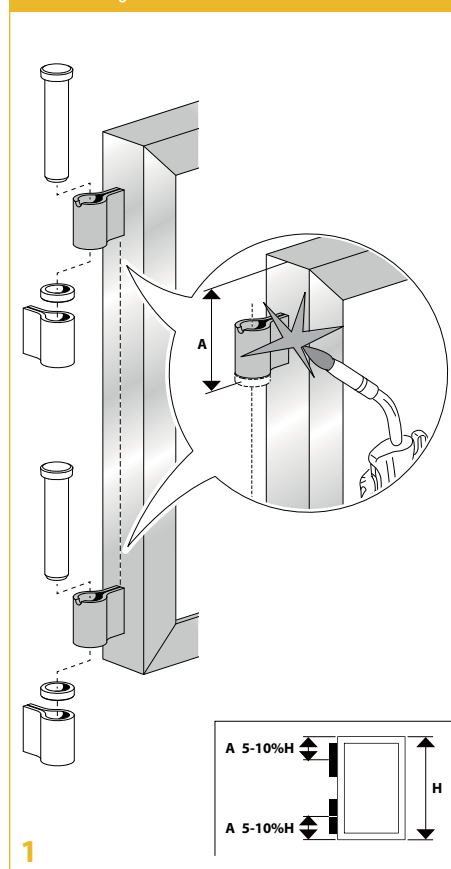

455

Cerniera a 2 ali chiuse perno sfilabile con cuscinetto

Big hinge 2 closed wings extractable pivot with bearing
Paumelle grande 2 ailes fermées avec pivot à déboîter et roulement
Flachband 2-teilig schwere Ausführung mit losem Zapfen und Kugellager
Perno grande de 2 palas cerradas eje extraíble con arandela y rodamiento
Большой шарнир с 2 закрытыми полками с вынимаемым штифтом с шайбой и подшипником



CODE	ART.	Portata - Kg Capacity - Kg	Box info	
			Pcs per pack	Kg
11609009	455-90	400	10	5,80

Finishing: Non zincato / Not galvanized

La portata è riferita ad una coppia di cerniere nel caso di peso uniformemente distribuito in un'anta con L=H.
Weight bearing capacity refers to a pair of hinges mounted on a gate with weight uniformly distributed on a leaf with proportions L=H.

Categoria commerciale: 1E

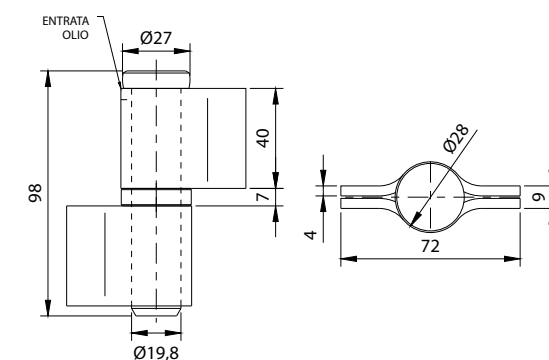

Peso uniformemente distribuito
Equally distributed weight

**PERNO ZINCATO
GALVANIZED PIN**



456

Cerniera a 2 ali lunghe aperte
perno sfilabile con rondella
Big hinge 2 open wings extractable pivot with washer
Paumelle grande 2 ailes ouvertes avec pivot à déboîter et rondelle
Winkelband 2-teilig schwere Ausführung mit losem Zapfen und Unterlegscheibe
Perno grande de 2 palas largas abiertas eje extraíble con arandela
Большой шарнир с 2 длинными открытыми полками с вынимаемым штифтом с шайбой



CODE	ART.	Portata - Kg Capacity - Kg	Box info	
			Pcs per pack	Kg
11609518	456-180	800	4	4,20

Finishing: Non zincato / Not galvanized

Categoria commerciale: 1E

La portata è riferita ad una coppia di cerniere nel caso di peso uniformemente distribuito in un'anta con L=H.
Weight bearing capacity refers to a pair of hinges mounted on a gate with weight uniformly distributed on a leaf with proportions L=H.

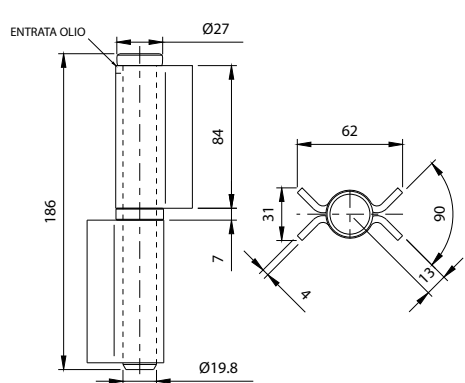

Peso uniformemente distribuito
Equally distributed weight

**PERNO ZINCATO
GALVANIZED PIN**

458

Cerniera a 2 ali lunghe chiuse
perno sfilabile con rondella
Big hinge 2 closed wings extractable pivot with washer
Paumelle grande 2 ailes fermées avec pivot à déboîter et rondelle
Flachband 2-teilig schwere Ausführung mit losem Zapfen und Unterlegscheibe
Perno grande de 2 palas largas cerradas eje extraíble con arandela
Большой шарнир с 2 длинными закрытыми полками с вынимаемым штифтом с шайбой



CODE	ART.	Portata - Kg Capacity - Kg	Box info	
			Pcs per pack	Kg
11610518	458-180	800	4	4,20

Finishing: Non zincato / Not galvanized

Categoria commerciale: 1E

La portata è riferita ad una coppia di cerniere nel caso di peso uniformemente distribuito in un'anta con L=H.
Weight bearing capacity refers to a pair of hinges mounted on a gate with weight uniformly distributed on a leaf with proportions L=H.

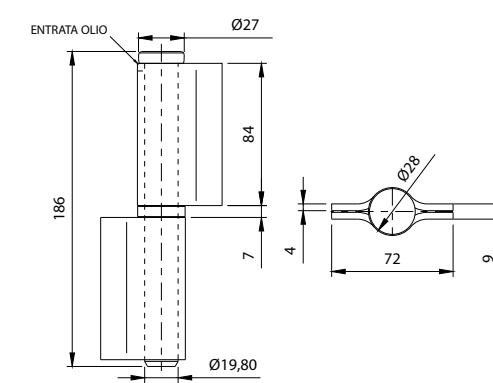

Peso uniformemente distribuito
Equally distributed weight

**PERNO ZINCATO
GALVANIZED PIN**

456i

Cerniera a 2 ali lunghe aperte
perno sfilabile con rondella in ottone
Big hinge 2 long open wings extractable pivot with washer and bearing
Paumelle grande 2 ailes grandes et ouvertes, pivot à déboîter avec rondelle et roulement
Winkelband mit 2 langen offenen Flügeln schwere Ausführung mit losem Zapfen, Unterlegscheibe und Kugellager
Perno grande de 2 palas largas abiertas eje extraíble con arandela de latón
Большой шарнир с 2 длинными открытыми полками с вынимаемым штифтом с латунной шайбой



CODE	ART.	Portata - Kg Capacity - Kg	Box info	
			Pcs per pack	Kg
11609618	456i-180	800	4	4,20

Finishing: Inox / Stainless steel

Categoria commerciale: 2E

La portata è riferita ad una coppia di cerniere nel caso di peso uniformemente distribuito in un'anta con L=H.
Weight bearing capacity refers to a pair of hinges mounted on a gate with weight uniformly distributed on a leaf with proportions L=H.

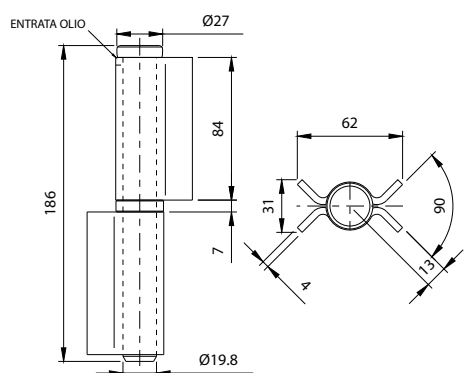

Peso uniformemente distribuito
Equally distributed weight



458i

Cerniera a 2 ali lunghe chiuse
perno sfilabile con rondella in ottone
Big hinge 2 closed wings extractable pivot with brass washer
Paumelle grande 2 ailes fermées avec pivot à déboîter et rondelle en laiton
Flachband 2-teilig schwere Ausführung mit losem Zapfen und Unterlegscheibe aus Messing
Perno grande de 2 palas largas cerradas eje extraíble con arandela de latón
Большой шарнир с 2 длинными закрытыми полками с вынимаемым штифтом с латунной шайбой



CODE	ART.	Portata - Kg Capacity - Kg	Box info	
			Pcs per pack	Kg
11610618	458i-180	800	4	4,20

Finishing: Inox / Stainless steel

Categoria commerciale: 2E

La portata è riferita ad una coppia di cerniere nel caso di peso uniformemente distribuito in un'anta con L=H.
Weight bearing capacity refers to a pair of hinges mounted on a gate with weight uniformly distributed on a leaf with proportions L=H.

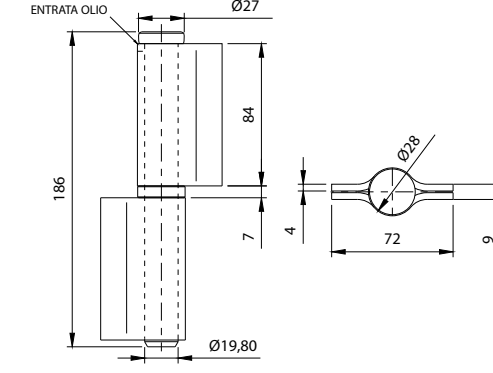

Peso uniformemente distribuito
Equally distributed weight



457

Cerniera a 2 ali aperte
perno sfilabile con cuscinetto
Big hinge 2 open wings extractable pivot with bearing
Paumelle grande 2 ailes ouvertes avec pivot à déboîter et roulement
Winkelband 2-teilig schwere Ausführung mit losem Zapfen und Unterlegscheibe
Perno grande de 2 palas abiertas eje extraíble con rodamiento
Большой шарнир с 2 открытыми полками с вынимаемым штифтом с подшипником



CODE	ART.	Portata - Kg Capacity - Kg	Box info	
			Pcs per pack	Kg
11610018	457-180	800	4	4,20

Finishing: Non zincato / Not galvanized

Categoria commerciale: 1E

La portata è riferita ad una coppia di cerniere nel caso di peso uniformemente distribuito in un'anta con L=H.
Weight bearing capacity refers to a pair of hinges mounted on a gate with weight uniformly distributed on a leaf with proportions L=H.

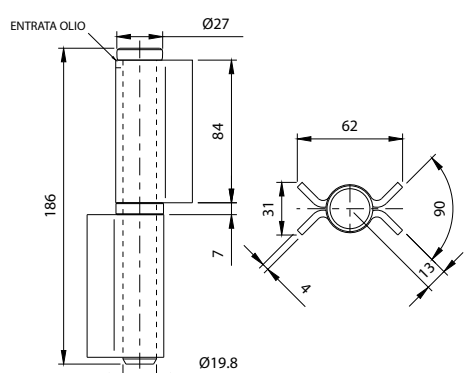

Peso uniformemente distribuito
Equally distributed weight

**PERNO ZINCATO
GALVANIZED PIN**

459

Cerniera a 2 ali lunghe chiuse
perno sfilabile con cuscinetto
Big hinge 2 long closed wings extractable pivot with bearing
Paumelle grande 2 ailes grandes et fermées, pivot à déboîter avec roulement
Winkelband mit 2 langen geschlossenen Flügeln schwere Ausführung mit losem Zapfen, Kugellager
Perno grande de 2 palas largas cerradas eje extraíble con rodamiento
Большой шарнир с 2 длинными закрытыми полками с подшипником



CODE	ART.	Portata - Kg Capacity - Kg	Box info	
			Pcs per pack	Kg
11611018	459-180	800	4	4,20

Finishing: Non zincato / Not galvanized

Categoria commerciale: 1E

La portata è riferita ad una coppia di cerniere nel caso di peso uniformemente distribuito in un'anta con L=H.
Weight bearing capacity refers to a pair of hinges mounted on a gate with weight uniformly distributed on a leaf with proportions L=H.

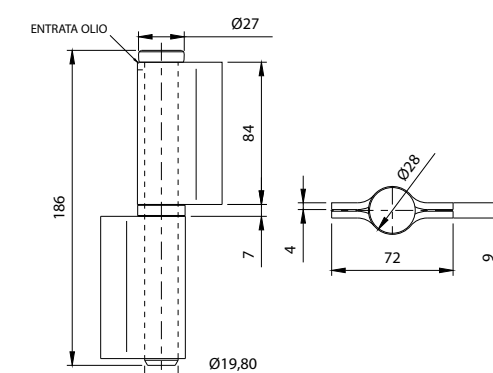

Peso uniformemente distribuito
Equally distributed weight

**PERNO ZINCATO
GALVANIZED PIN**



460

Cerniera a 3 ali aperte
perno sfilabile con rondelle

Big hinge 3 open wings with washer
Paumelle grande 3 ailes ouvertes pivot à déboîter avec rondelle
Winkelband 3-teilig schwere Ausführung mit Unterlegscheiben
Perno grande de 3 palas abiertas eje extraíble con arandelas
Большой шарнир с 3 открытыми полками с вынимаемым штифтом с шайбами



CODE	ART.	Portata - Kg Capacity - Kg	Box info	
			Pcs per pack	Kg
11611518	460-180	800	4	4,30

Finishing: Non zincato / Not galvanized

Categoria commerciale: 1E

La portata è riferita ad una coppia di cerniere nel caso di peso uniformemente distribuito in un'anta con L=H.
Weight bearing capacity refers to a pair of hinges mounted on a gate with weight uniformly distributed on a leaf with proportions L=H.

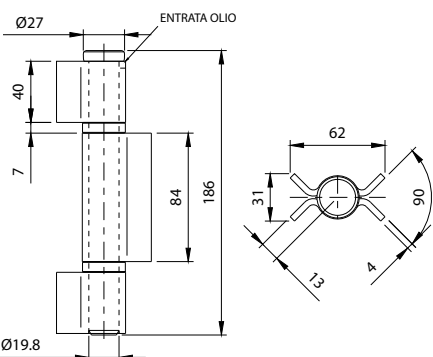

Peso uniformemente distribuito
Equally distributed weight

**PERNO ZINCATO
GALVANIZED PIN**

470

Cerniera a 3 ali chiuse perno
sfilabile con rondella

Big hinge 3 closed wings extractable pivot with washer
Paumelle grande 3 ailes fermées avec pivot à déboîter et rondelle
Flachband 3-teilig schwere Ausführung mit losem Zapfen und Unterlegscheibe
Perno grande de 3 palas cerradas eje extraíble con arandela
Большой шарнир с 3 закрытыми полками с вынимаемым штифтом с шайбой



CODE	ART.	Portata - Kg Capacity - Kg	Box info	
			Pcs per pack	Kg
11612518	470-180	800	4	4,20

Finishing: Non zincato / Not galvanized

Categoria commerciale: 1E

La portata è riferita ad una coppia di cerniere nel caso di peso uniformemente distribuito in un'anta con L=H.
Weight bearing capacity refers to a pair of hinges mounted on a gate with weight uniformly distributed on a leaf with proportions L=H.

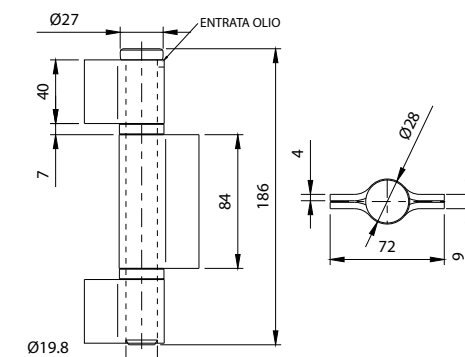

Peso uniformemente distribuito
Equally distributed weight

**PERNO ZINCATO
GALVANIZED PIN**

460i

Cerniera a 3 ali aperte
perno sfilabile con rondelle in ottone

Big hinge 3 open wings extractable pivot with brass washers
Paumelle grande 3 ailes ouvertes avec pivot à déboîter et rondelles en laiton
Winkelband 3-teilig schwere Ausführung mit losem Zapfen und Unterlegscheibe aus Messing
Perno grande de 3 palas abiertas eje extraíble con arandelas de latón
Большой шарнир с 3 открытыми полками с вынимаемым штифтом с латунными шайбами



CODE	ART.	Portata - Kg Capacity - Kg	Box info	
			Pcs per pack	Kg
11611618	460i-180	800	4	4,30

Finishing: Inox / Stainless steel

Categoria commerciale: 2E

La portata è riferita ad una coppia di cerniere nel caso di peso uniformemente distribuito in un'anta con L=H.
Weight bearing capacity refers to a pair of hinges mounted on a gate with weight uniformly distributed on a leaf with proportions L=H.

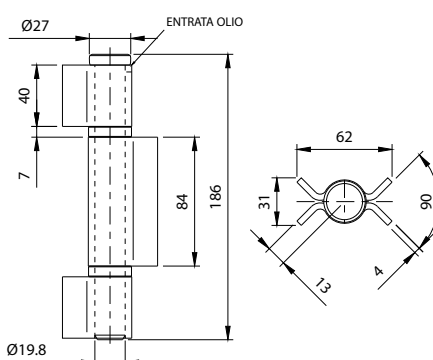

Peso uniformemente distribuito
Equally distributed weight



470i

Cerniera a 3 ali chiuse perno
sfilabile con rondella in ottone

Big hinge 3 closed wings extractable pivot with washer
Paumelle grande 3 ailes fermées avec pivot à déboîter et rondelle
Flachband 3-teilig schwere Ausführung mit losem Zapfen und Unterlegscheibe
Perno grande de 3 palas cerradas eje extraíble con arandela de latón
Большой шарнир с 3 закрытыми полками с вынимаемым штифтом с латунной шайбой



CODE	ART.	Portata - Kg Capacity - Kg	Box info	
			Pcs per pack	Kg
11612618	470i-180	800	4	4,20

Finishing: Inox / Stainless steel

Categoria commerciale: 2E

La portata è riferita ad una coppia di cerniere nel caso di peso uniformemente distribuito in un'anta con L=H.
Weight bearing capacity refers to a pair of hinges mounted on a gate with weight uniformly distributed on a leaf with proportions L=H.

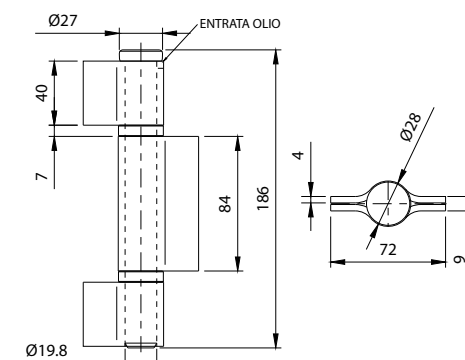

Peso uniformemente distribuito
Equally distributed weight

**PERNO ZINCATO
GALVANIZED PIN**



465

Cerniera a 3 ali aperte perno sfilabile
con cuscinetto

Big hinge 3 open wings extractable pivot with bearing
Paumelle grande 3 ailes ouvertes pivot à déboîter avec roulement
Winkelband mit 3 offenen Flügeln schwere Ausführung mit losem Zapfen, Kugellager
Perno grande de 3 palas abiertas eje extraíble con rodamiento
Большой шарнир с 3 открытыми полками с вынимаемым штифтом с подшипником



CODE	ART.	Portata - Kg Capacity - Kg	Box info	
			Pcs per pack	Kg
11612018	465-180	800	4	4,30

Finishing: Non zincato / Not galvanized

Categoria commerciale: 1E

La portata è riferita ad una coppia di cerniere nel caso di peso uniformemente distribuito in un'anta con L=H.
Weight bearing capacity refers to a pair of hinges mounted on a gate with weight uniformly distributed on a leaf with proportions L=H.

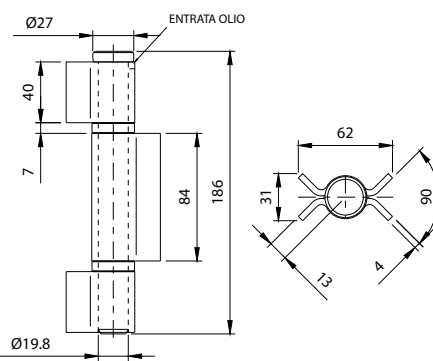

Peso uniformemente distribuito
Equally distributed weight

**PERNO ZINCATO
GALVANIZED PIN**

475

Cerniera a 3 ali chiuse perno
sfilabile con cuscinetto

Big hinge 3 closed wings extractable pivot and bearing
Paumelle grande 3 ailes fermées pivot à déboîter avec roulement
Winkelband mit 3 geschlossenen Flügeln schwere Ausführung mit losem Zapfen, Kugellager
Perno grande de 3 palas cerradas eje extraíble con rodamiento
Большой шарнир с 3 закрытыми полками с вынимаемым штифтом с подшипником



CODE	ART.	Portata - Kg Capacity - Kg	Box info	
			Pcs per pack	Kg
11613018	457-180	800	4	4,20

Finishing: Non zincato / Not galvanized

Categoria commerciale: 1E

La portata è riferita ad una coppia di cerniere nel caso di peso uniformemente distribuito in un'anta con L=H.
Weight bearing capacity refers to a pair of hinges mounted on a gate with weight uniformly distributed on a leaf with proportions L=H.

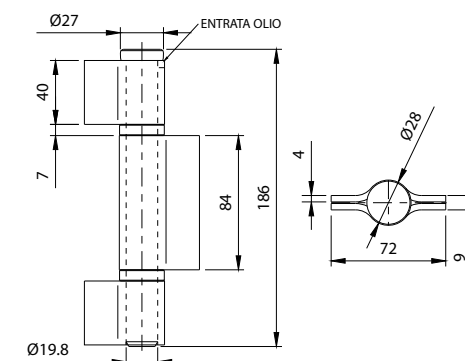

Peso uniformemente distribuito
Equally distributed weight

**PERNO ZINCATO
GALVANIZED PIN**



480

Cerniera a 4 ali aperte
perno sfilabile con rondella

Big hinge 4 open wings extractable pivot with washer
Paumelle grande 4 ailes ouvertes avec pivot à déboîter et rondelle
Winkelband 4-teilig schwere Ausführung mit losem Zapfen und Unterlegscheibe
Perno grande de 4 palas abiertas con eje extraíble con arandela
Большой шарнир с 4 открытыми полками с вынимаемым штифтом с шайбой

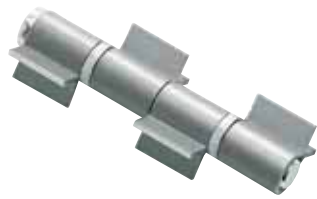

CODE	ART.	Portata - Kg Capacity - Kg	Box info	
			Pcs per pack	Kg
11613518	480-180	800	4	4,20

Finishing: Non zincato / Not galvanized

Categoria commerciale: 1E

La portata è riferita ad una coppia di cerniere nel caso di peso uniformemente distribuito in un'anta con L=H.
Weight bearing capacity refers to a pair of hinges mounted on a gate with weight uniformly distributed on a leaf with proportions L=H.

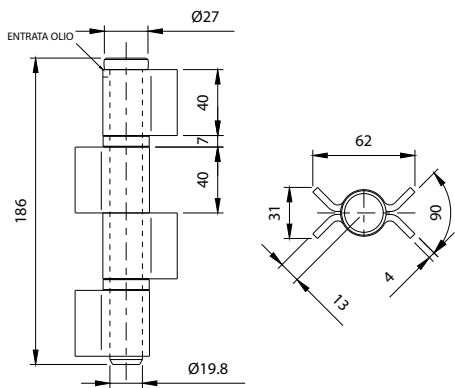

Peso uniformemente distribuito
Equally distributed weight

PERNO ZINCATO
GALVANIZED PIN

485

Cerniera a 4 ali chiuse
perno sfilabile con rondelle

Big hinge 4 closed wings extractable pivot with washers
Paumelle grande 4 ailes fermées avec pivot à déboîter et rondelles
Flachband 4-teilig schwere Ausführung mit losem Zapfen und Unterlegscheiben
Perno grande de 4 palas cerradas eje extraíble con arandelas
Большой шарнир с 4 закрытыми полками с вынимаемым штифтом с шайбами



CODE	ART.	Portata - Kg Capacity - Kg	Box info	
			Pcs per pack	Kg
11614518	485-180	800	4	4,20

Finishing: Non zincato / Not galvanized

Categoria commerciale: 1E

La portata è riferita ad una coppia di cerniere nel caso di peso uniformemente distribuito in un'anta con L=H.
Weight bearing capacity refers to a pair of hinges mounted on a gate with weight uniformly distributed on a leaf with proportions L=H.

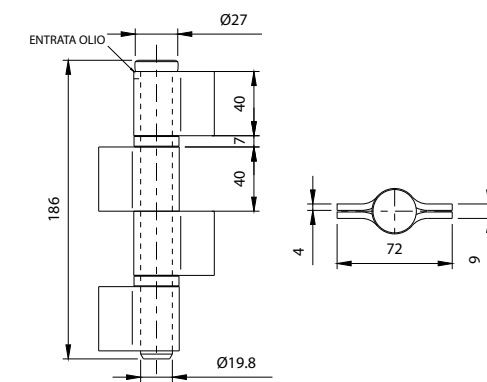

Peso uniformemente distribuito
Equally distributed weight

PERNO ZINCATO
GALVANIZED PIN

480i

Cerniera a 4 ali aperte
perno sfilabile con rondelle in ottone

Big hinge 4 open wings extractable pivot with brass washers
Paumelle grande 4 ailes ouvertes avec pivot à déboîter et rondelles en laiton
Winkelband 4-teilig schwere Ausführung mit losem Zapfen und Unterlegscheiben aus Messing
Perno grande de 4 palas abiertas con eje extraíble con arandelas de latón
Большой шарнир с 4 открытыми полками с вынимаемым штифтом с латунными шайбами



CODE	ART.	Portata - Kg Capacity - Kg	Box info	
			Pcs per pack	Kg
11613618	480i-180	800	4	4,20

Finishing: Inox / Stainless steel

Categoria commerciale: 2E

La portata è riferita ad una coppia di cerniere nel caso di peso uniformemente distribuito in un'anta con L=H.
Weight bearing capacity refers to a pair of hinges mounted on a gate with weight uniformly distributed on a leaf with proportions L=H.

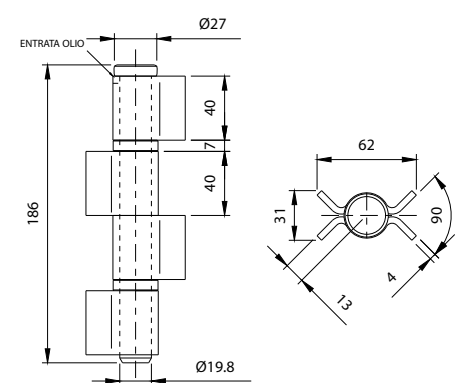

Peso uniformemente distribuito
Equally distributed weight



485i

Cerniera a 4 ali chiuse
perno sfilabile con rondelle in ottone

Big hinge 4 closed wings extractable pivot with brass washers
Paumelle grande 4 ailes fermées avec rondelles et pivot à déboîter
Flachband 4-teilig schwere Ausführung mit losen Zapfen und Unterlegscheiben aus Messing
Perno grande de 4 palas cerradas eje extraíble con arandelas de latón
Большой шарнир с 4 закрытыми полками с вынимаемым штифтом с латунными шайбами

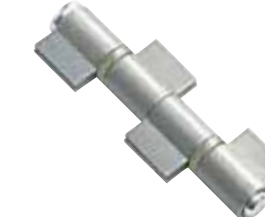

CODE	ART.	Portata - Kg Capacity - Kg	Box info	
			Pcs per pack	Kg
11614618	485i-180	800	4	4,20

Finishing: Inox / Stainless steel

Categoria commerciale: 2E

La portata è riferita ad una coppia di cerniere nel caso di peso uniformemente distribuito in un'anta con L=H.
Weight bearing capacity refers to a pair of hinges mounted on a gate with weight uniformly distributed on a leaf with proportions L=H.

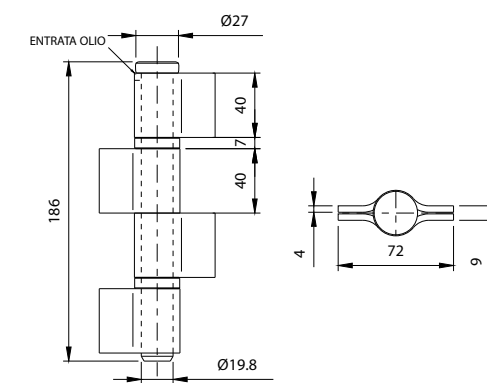

Peso uniformemente distribuito
Equally distributed weight



482

Cerniera a 4 ali chiuse
perno sfilabile con cuscinetto

Big hinge 4 closed wings extractable pivot with bearing
Paumelle grande 4 ailes fermées pivot à déboîter avec roulement
Winkelband mit 4 geschlossenen Flügeln schwere Ausführung mit losem Zapfen und Kugellager
Perno grande de 4 palas cerradas eje extraíble con rodamiento
Большой шарнир с 4 закрытыми полками с вынимаемым штифтом с подшипником



CODE	ART.	Portata - Kg Capacity - Kg	Box info	
			Pcs per pack	Kg
11614018	482-180	800	4	4,20

Finishing: Non zincato / Not galvanized

Categoria commerciale: 1E

La portata è riferita ad una coppia di cerniere nel caso di peso uniformemente distribuito in un'anta con L=H.
Weight bearing capacity refers to a pair of hinges mounted on a gate with weight uniformly distributed on a leaf with proportions L=H.

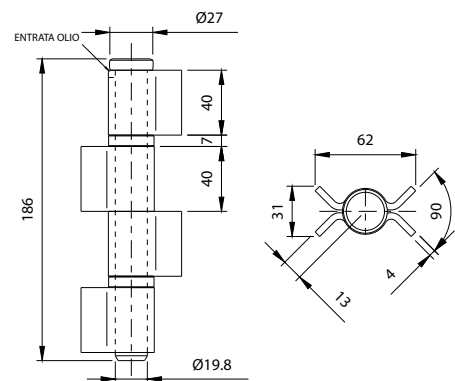

Peso uniformemente distribuito
Equally distributed weight

PERNO ZINCATO
GALVANIZED PIN

487

Cerniera a 4 ali chiuse
perno sfilabile con cuscinetto

Big hinge 4 closed wings extractable pivot with bearing
Paumelle grande 4 ailes fermées pivot à déboîter avec roulement
Winkelband mit 4 geschlossenen Flügeln schwere Ausführung mit losem Zapfen und Kugellager
Perno grande de 4 palas cerradas eje extraíble con rodamiento
Большой шарнир с 4 закрытыми полками с вынимаемым штифтом с подшипником



CODE	ART.	Portata - Kg Capacity - Kg	Box info	
			Pcs per pack	Kg
11615018	487-180	800	4	4,20

Finishing: Non zincato / Not galvanized

Categoria commerciale: 1E

La portata è riferita ad una coppia di cerniere nel caso di peso uniformemente distribuito in un'anta con L=H.
Weight bearing capacity refers to a pair of hinges mounted on a gate with weight uniformly distributed on a leaf with proportions L=H.

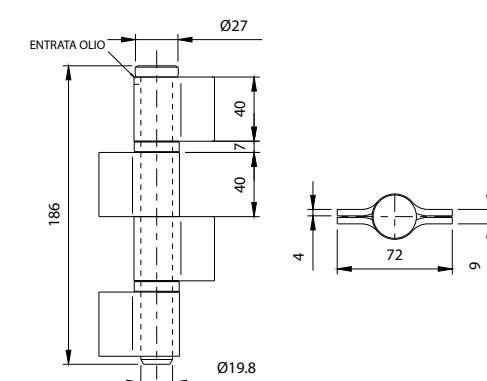

Peso uniformemente distribuito
Equally distributed weight

PERNO ZINCATO
GALVANIZED PIN



490

Cerniera a goccia con perno in acciaio

Drop hinge with steel pivot
Paumelle à goutte avec pivot en acier
Bandrolle mit Zapfen aus Stahl
Pernio grande gota de agua con eje de acero
Шарнир "капля" со стальным штифтом



CODE	ART.	A	C	D	E	L	S	Portata - Kg Capacity - Kg	Box info	
									Pcs per pack	Kg
11647010	490-100	48	16	Ø9	13	98	2,5	150	40	4,35
11647012	490-120	58	20	Ø9	16	118	2,5	200	40	7,90
11647014	490-140	68	20	Ø9	16	139	2,5	300	40	9,30

Finishing: Non zincato / Not galvanized

Categoria commerciale: 1E

La portata è riferita ad una coppia di cerniere nel caso di peso uniformemente distribuito in un'anta con L=H.
Weight bearing capacity refers to a pair of hinges mounted on a gate with weight uniformly distributed on a leaf with proportions L=H.

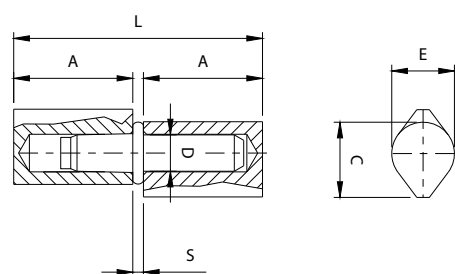

Peso uniformemente distribuito
Equally distributed weight

492

Cerniera a goccia
perno in acciaio rivestito ottone

Drop hinge with brass-covered, steel pivot
Paumelle à goutte avec pivot en acier revêtu de laiton
Bandrolle mit Messing beschichtetem Zapfen aus Stahl
Pernio gota de agua eje de acero recubierto de latón
Шарнир "капля" со стальным штифтом с латунным покрытием



CODE	ART.	A	C	D	E	L	S	Portata - Kg Capacity - Kg	Box info	
									Pcs per pack	Kg
11647110	492-100	48	16	Ø9	13	98	2,5	100	40	4,35
11647112	492-120	58	20	Ø9	16	118	2,5	125	40	7,90
11647114	492-140	68	20	Ø9	16	139	2,5	180	40	9,30

Finishing: Non zincato / Not galvanized

Categoria commerciale: 1E

La portata è riferita ad una coppia di cerniere nel caso di peso uniformemente distribuito in un'anta con L=H.
Weight bearing capacity refers to a pair of hinges mounted on a gate with weight uniformly distributed on a leaf with proportions L=H.

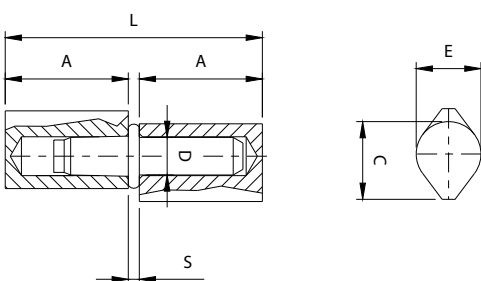

Peso uniformemente distribuito
Equally distributed weight

494

Cerniera a goccia
perno in acciaio con rondella

Drop Hinge With Steel Pivot And Washer
Paumelle à goutte avec pivot en acier avec rondelle
Bandrolle mit Zapfen aus Stahl mit Unterlegscheibe
Pernio gota de agua eje de acero con arandela
Шарнир "капля" со стальным штифтом с шайбой



CODE	ART.	A	C	D	E	L	S	Portata - Kg Capacity - Kg	Box info	
									Pcs per pack	Kg
11647210	494-100	46	25	Ø12	20	100	7	150	16	3,90
11647215	494-150	71	25	Ø12	20	149	7	250	16	5,40

Finishing: Non zincato / Not galvanized

Categoria commerciale: 1E

La portata è riferita ad una coppia di cerniere nel caso di peso uniformemente distribuito in un'anta con L=H.
Weight bearing capacity refers to a pair of hinges mounted on a gate with weight uniformly distributed on a leaf with proportions L=H.

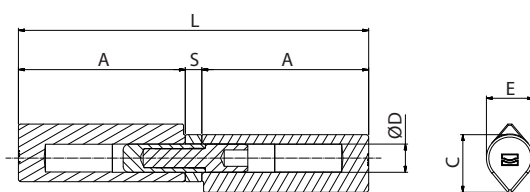

Peso uniformemente distribuito
Equally distributed weight

495

Cerniera a goccia
perno in acciaio con cuscinetto

Drop Hinge With Steel Pivot And Bearing
Paumelle à goutte avec pivot en acier avec roulement
Bandrolle mit Zapfen aus Stahl mit Kugellager
Pernio gota de agua eje de acero con rodamiento
Шарнир "капля" со стальным штифтом с подшипником



CODE	ART.	A	C	D	E	L	S	Portata - Kg Capacity - Kg	Box info	
									Pcs per pack	Kg
11647310	495-100	46	25	Ø12	20	100	7	150	16	3,50
11647315	495-150	71	25	Ø12	20	149	7	250	16	5,10

Finishing: Non zincato / Not galvanized

Categoria commerciale: 1E

La portata è riferita ad una coppia di cerniere nel caso di peso uniformemente distribuito in un'anta con L=H.
Weight bearing capacity refers to a pair of hinges mounted on a gate with weight uniformly distributed on a leaf with proportions L=H.

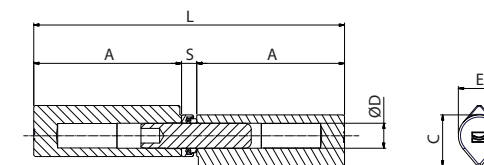

Peso uniformemente distribuito
Equally distributed weight

496

Cerniera a goccia perno rivestito in
ottone con rondella

Drop Hinge With Brass-Covered, Steel/Pivot And Washer
Paumelle à goutte avec pivot revêtu de laiton avec rondelle
Bandrolle mit Messing beschichtetem Zapfen mit Unterlegscheibe
Pernio gota de agua eje recubierto de latón con arandela
Шарнир "капля" со штифтом с латунным покрытием с шайбой



CODE	ART.	A	C	D	E	L	S	Portata - Kg Capacity - Kg	Box info	
									Pcs per pack	Kg
11647410	496-100	46	25	Ø12	20	100	7	100	16	3,90
11647415	496-150	71	25	Ø12	20	149	7	180	16	5,60

Finishing: Non zincato / Not galvanized

Categoria commerciale: 1E

La portata è riferita ad una coppia di cerniere nel caso di peso uniformemente distribuito in un'anta con L=H.
Weight bearing capacity refers to a pair of hinges mounted on a gate with weight uniformly distributed on a leaf with proportions L=H.

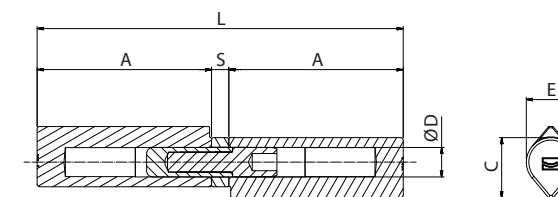

Peso uniformemente distribuito
Equally distributed weight

497

Cerniera a goccia perno ottone con
cuscinetto

Drop hinge with brass pivot and bearing
Paumelle à goutte avec pivot en laiton avec rondelle
Bandrolle mit Zapfen aus Messing mit Kugellager
Pernio gota de agua eje latón con rodamiento
Шарнир "капля" с латунным штифтом с подшипником



CODE	ART.	A	C	D	E	L	S	Portata - Kg Capacity - Kg	Box info	
									Pcs per pack	Kg
11648010	497-100	46	25	Ø12	20	100	7	100	10	2,60
11648015	497-150	71	25	Ø12	20	149	7	180	10	4,00
11648010 001	497Z-100	46	25	Ø12	20	100	7	100	10	4,20
11648015 001	497Z-150	71	25	Ø12	20	149	7	180	16	5,80

Finishing: Non zincato / Not galvanized

Categoria commerciale: 1E

La portata è riferita ad una coppia di cerniere nel caso di peso uniformemente distribuito in un'anta con L=H.
Weight bearing capacity refers to a pair of hinges mounted on a gate with weight uniformly distributed on a leaf with proportions L=H.

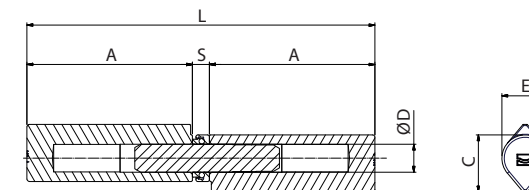

Peso uniformemente distribuito
Equally distributed weight



498 - 498Z

Cerniera a goccia con perno in acciaio rivestito ottone con cuscinetto

Drop hinge with brass-covered, steel pivot and bearing
Paumelle à goutte avec pivot en acier revêtu de laiton avec roulement

Bandrolle mit Messing beschichtetem Zapfen aus Stahl mit Kugellager

Perno gota de agua con eje de acero recubierto de latón con rodamiento

Шарнир "капля" со стальным штифтом с латунным покрытием с подшипником



CODE	ART.	A	D	L	Finishing	Portata - Kg Capacity - Kg	Box info	
							Pcs per pack	Kg
11648110	498-100	46	Ø12	100	Raw	100	16	4,20
11648115	498-150	71	Ø12	149	Raw	180	16	5,60

Finishing: Non zincato / Not galvanized

11648110 001	498Z-100	46	Ø12	100	Zinc	100	16	4,20
11648115 001	498Z-150	71	Ø12	149	Zinc	180	16	5,60

Finishing: Zincato / Galvanized

Categoria commerciale: 1E

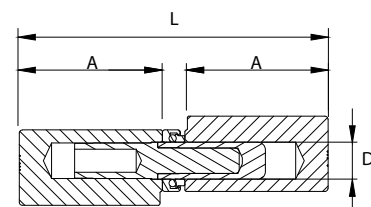

PATENTED

500

Cerniera a goccia tomata perno acciaio regolabile 7 mm

Turned drop hinge, 7mm adjustable, with steel pivot
Paumelle à goutte tournée, réglable 7mm. avec pivot en acier Formgepresstes und 7 mm-verstellbares Tropfenband mit Zapfen aus Stahl

Perno gota de agua torneada eje de acero regulable 7 mm
Шарнир "капля" обточенный с регулируемым стальным штифтом 7 мм



CODE	ART.	A	Portata - Kg Capacity - Kg	Box info	
				Pcs per pack	Kg
11618515	500-150	146-153	300	10	4,00

Finishing: Non zincato / Not galvanized

La portata è riferita ad una coppia di cerniere nel caso di peso uniformemente distribuito in un'anta con L=H.
Weight bearing capacity refers to a pair of hinges mounted on a gate with weight uniformly distributed on a leaf with proportions L=H.

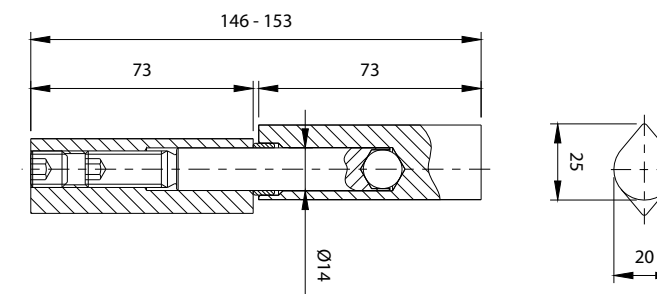

Peso uniformemente distribuito
Equally distributed weight

PERNO ZINCATO
GALVANIZED PIN

500i

Cerniera a goccia tomata perno acciaio regolabile 7 mm

Turned drop hinge, 7mm adjustable, with steel pivot
Paumelle à goutte tournée, réglable 7mm. avec pivot en acier Formgepresstes und 7 mm-verstellbares Tropfenband mit Zapfen aus Stahl

Perno gota de agua torneada eje de acero regulable 7 mm
Шарнир "капля" обточенный с регулируемым стальным штифтом 7 мм



CODE	ART.	R	Portata - Kg Capacity - Kg	Box info	
				Pcs per pack	Kg
11618615	500i-150	146-153	300	10	4,00

Finishing: Inox / Stainless steel

La portata è riferita ad una coppia di cerniere nel caso di peso uniformemente distribuito in un'anta con L=H.
Weight bearing capacity refers to a pair of hinges mounted on a gate with weight uniformly distributed on a leaf with proportions L=H.

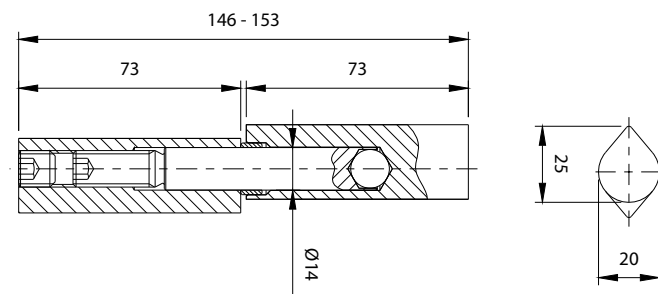

Peso uniformemente distribuito
Equally distributed weight

Mounting instructions art. 500

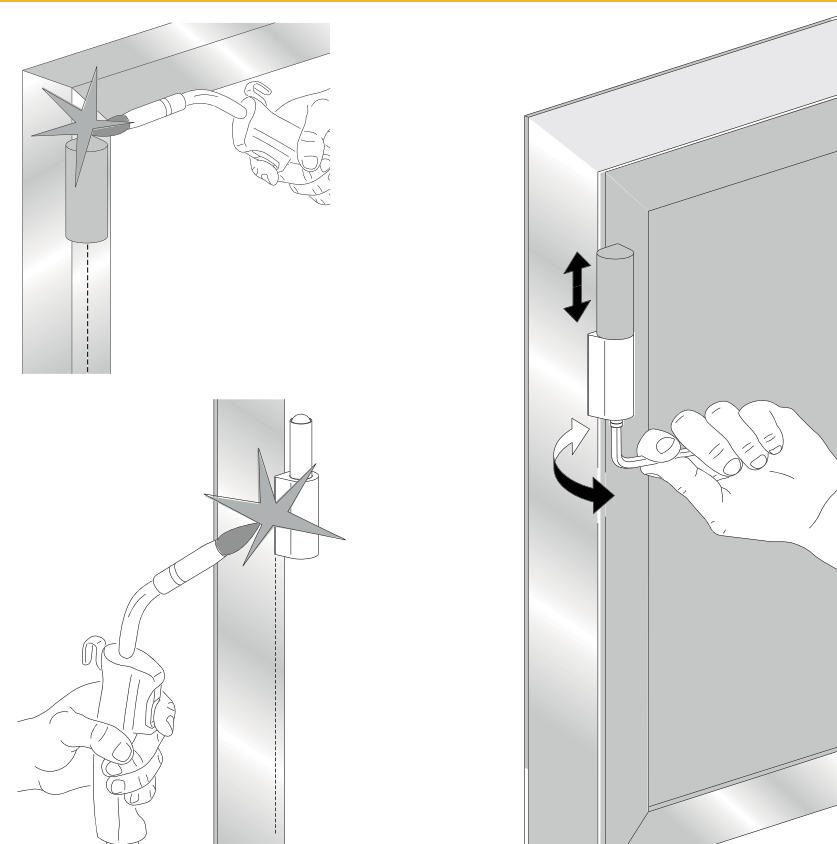



505

Cerniera ala lunga reversibile con rondella perno acciaio

Big hinge long wing steel pivot with washer
Paumelle grande aile longue réversible pivot en acier avec rondelle
Scharnier mit langem Flügel, Kugellager und Zapfen aus Stahl
Perno pala larga reversible con arandela eje de acero
Реверсивный шарнир с длинной полкой с шайбой и стальным штифтом



CODE	ART.	Portata - Kg Capacity - Kg	Box info	
			Pcs per pack	Kg
11619015	505-150	600	10	7,10

Finishing: Non zincato / Not galvanized

Categoria commerciale: 1E

La portata è riferita ad una coppia di cerniere nel caso di peso uniformemente distribuito in un'anta con L=H.
Weight bearing capacity refers to a pair of hinges mounted on a gate with weight uniformly distributed on a leaf with proportions L=H.

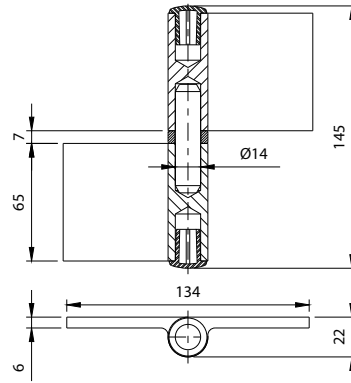

Peso uniformemente distribuito
Equally distributed weight

520

Cerniera ala lunga reversibile perno ottone

Hinge with reversible long wing and brass pivot
Paumelle avec aile longue réversible et pivot en laiton
Umkehrbares Scharnier mit langem Flügel und Zapfen aus Messing
Perno pala larga reversible eje de latón
Реверсивный шарнир с длинной полкой с латунным штифтом



CODE	ART.	Portata - Kg Capacity - Kg	Box info	
			Pcs per pack	Kg
11620515	520-150	450	10	7,00

Finishing: Non zincato / Not galvanized

Categoria commerciale: 1E

La portata è riferita ad una coppia di cerniere nel caso di peso uniformemente distribuito in un'anta con L=H.
Weight bearing capacity refers to a pair of hinges mounted on a gate with weight uniformly distributed on a leaf with proportions L=H.

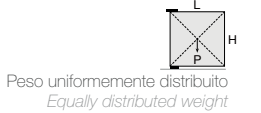
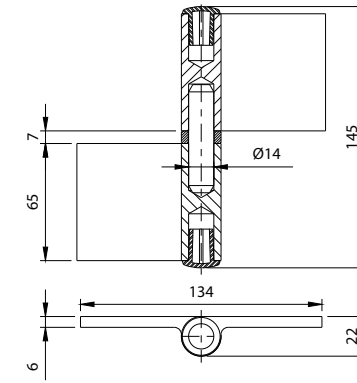

Peso uniformemente distribuito
Equally distributed weight

510

Cerniera ala lunga reversibile con cuscinetto perno acciaio

Big hinge long wing steel pivot with bearing
Paumelle grande aile longue réversible pivot en acier avec roulement
Scharnier mit langem Flügel, Kugellager und Zapfen aus Stahl
Perno grande pala larga reversible con rodamiento eje de acero
Реверсивный большой шарнир с длинной полкой с подшипником и стальным штифтом



CODE	ART.	Portata - Kg Capacity - Kg	Box info	
			Pcs per pack	Kg
11619515	510-150	600	10	7,10

Finishing: Non zincato / Not galvanized

Categoria commerciale: 1E

La portata è riferita ad una coppia di cerniere nel caso di peso uniformemente distribuito in un'anta con L=H.
Weight bearing capacity refers to a pair of hinges mounted on a gate with weight uniformly distributed on a leaf with proportions L=H.

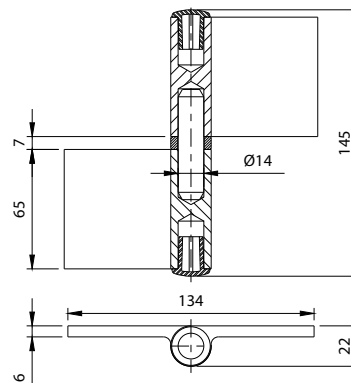

Peso uniformemente distribuito
Equally distributed weight

525

Cerniera ala lunga reversibile e ala a goccia perno acciaio con cuscinetto

Big hinge long and drop wing with bearing
Paumelle grande aile longue réversible avec roulement
Scharnier mit langem Flügel und Tropfenflügel, Zapfen aus Stahl und Kugellager
Perno grande pala larga reversible y pala gota de agua eje de acero con rodamiento
Реверсивный большой шарнир с длинной полкой и полкой "капля" с подшипником и стальным штифтом



CODE	ART.	Portata - Kg Capacity - Kg	Box info	
			Pcs per pack	Kg
11621015	525-150	300	10	5,70

Finishing: Non zincato / Not galvanized

Categoria commerciale: 1E

La portata è riferita ad una coppia di cerniere nel caso di peso uniformemente distribuito in un'anta con L=H.
Weight bearing capacity refers to a pair of hinges mounted on a gate with weight uniformly distributed on a leaf with proportions L=H.

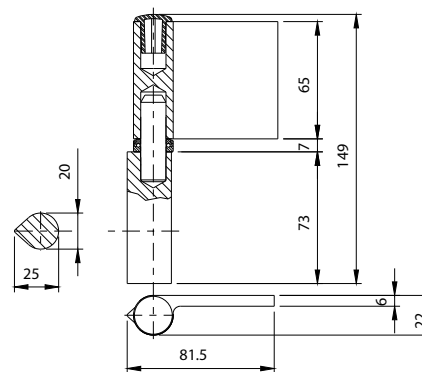

Peso uniformemente distribuito
Equally distributed weight

515

Cerniera regolabile 7mm ala lunga perno acciaio

Hinge, 7mm adjustable, with long wing and steel pivot
Paumelle réglable 7mm, avec aile longue et pivot en acier
7 mm-verstellbares Scharnier mit langem Flügel und Zapfen aus Stahl
Perno regulable 7 mm pala larga eje de acero
Регулируемый шарнир 7 мм длинная полка стальной штифт



CODE	ART.	R	Portata - Kg Capacity - Kg	Box info	
				Pcs per pack	Kg
11620015	515-150	138-145	600	10	7,20

Finishing: Non zincato / Not galvanized

Categoria commerciale: 1E

La portata è riferita ad una coppia di cerniere nel caso di peso uniformemente distribuito in un'anta con L=H.
Weight bearing capacity refers to a pair of hinges mounted on a gate with weight uniformly distributed on a leaf with proportions L=H.

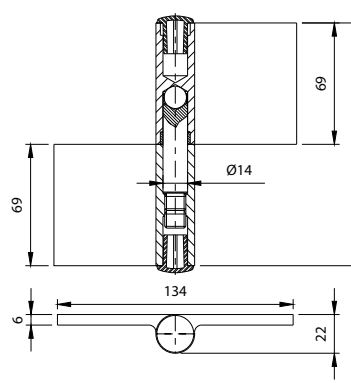

Peso uniformemente distribuito
Equally distributed weight

PERNO ZINCATO
GALVANIZED PIN

530

Cerniera ala lunga reversibile perno ottone

Hinge with reversible long wing and brass pivot
Paumelle avec aile longue réversible et pivot en laiton
Umkehrbares Scharnier mit langem Flügel und Zapfen aus Messing
Perno pala larga reversible eje de latón
Реверсивный шарнир с длинной полкой с латунным штифтом



CODE	ART.	R	Portata - Kg Capacity - Kg	Box info	
				Pcs per pack	Kg
11621515	530-150	142-149	300	10	5,30

Finishing: Non zincato / Not galvanized

Categoria commerciale: 1E

La portata è riferita ad una coppia di cerniere nel caso di peso uniformemente distribuito in un'anta con L=H.
Weight bearing capacity refers to a pair of hinges mounted on a gate with weight uniformly distributed on a leaf with proportions L=H.

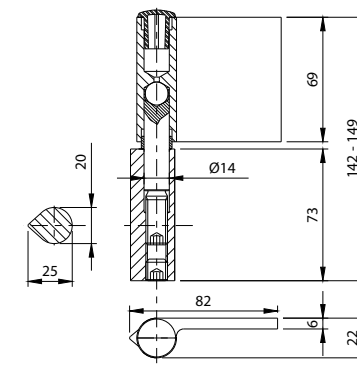

Peso uniformemente distribuito
Equally distributed weight





550

Maxi cerniera a 2 ali
Big hinge with 2 wings
Grande paumelle avec 2 ailes
Maxi-Schemier 2-teilig
Maxi-pernio de 2 palas
Максишарнир с 2 полками



CODE	ART.	Portata - Kg Capacity - Kg	Box info	
			Pcs per pack	Kg
11622030	550-300	800	4	8,40

Finishing: Non zincato / Not galvanized

Categoria commerciale: 1E

La portata è riferita ad una coppia di cerniere nel caso di peso uniformemente distribuito in un'anta con L=H.
Weight bearing capacity refers to a pair of hinges mounted on a gate with weight uniformly distributed on a leaf with proportions L=H.

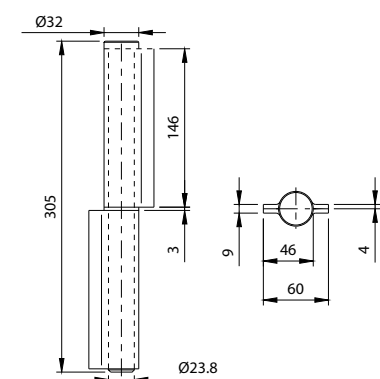

Peso uniformemente distribuito
Equally distributed weight

PERNO ZINCATO
GALVANIZED PIN



560

Cerniera a goccia perno in acciaio con rondella
Drop hinge with steel pivot and washer
Paumelle à goutte avec pivot en acier avec rondelle
Bandrolle mit Zapfen aus Stahl mit Unterlegscheibe
Pernio gota de agua eje de acero con arandela
Шарнир "капля" со стальным штифтом с шайбой



CODE	ART.	A	C	D	E	L	S	Box info		
								Portata - Kg Capacity - Kg	Pcs per pack	Kg
11628506	560-60	29	12	Ø6	10	59,5	1,5	75	40	1,60
11647608	560-80	39	16	Ø7	13	80	2	110	50	4,10
11647610	560-100	48	20	Ø9	16	98	2	150	40	6,0
11647612	560-120	58	20	Ø9	16	118	2	225	40	6,90
11647614	560-140	68	25	Ø12	20	138	2	260	20	6,70
11628516	560-160	77	25	Ø12	20	156	2	300	10	4,20
11628518	560-180	86	25	Ø12	20	175	2	330	10	4,70

Finishing: Non zincato / Not galvanized

Categoria commerciale: 1E

La portata è riferita ad una coppia di cerniere nel caso di peso uniformemente distribuito in un'anta con L=H.
Weight bearing capacity refers to a pair of hinges mounted on a gate with weight uniformly distributed on a leaf with proportions L=H.

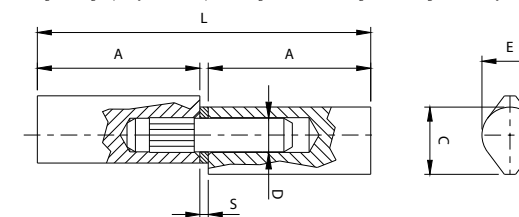

Peso uniformemente distribuito
Equally distributed weight

PERNO ZINCATO
GALVANIZED PIN

551

Maxi cerniera a 3 ali
Big hinge with 3 wings
Grande paumelle avec 3 ailes
Maxi-Schemier 3-teilig
Maxi-pernio de 3 palas
Максишарнир с 3 полками



CODE	ART.	Portata - Kg Capacity - Kg	Box info	
			Pcs per pack	Kg
11622530	551-300	1000	4	8,30

Finishing: Non zincato / Not galvanized

Categoria commerciale: 1E

La portata è riferita ad una coppia di cerniere nel caso di peso uniformemente distribuito in un'anta con L=H.
Weight bearing capacity refers to a pair of hinges mounted on a gate with weight uniformly distributed on a leaf with proportions L=H.

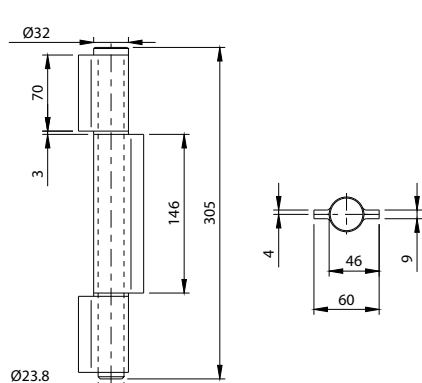

Peso uniformemente distribuito
Equally distributed weight

PERNO ZINCATO
GALVANIZED PIN



564

Cerniera a goccia perno in acciaio con cuscinetto
Drop hinge with steel pivot and bearing
Paumelle à goutte avec pivot en acier avec roulement
Bandrolle mit Zapfen aus Stahl mit Kugellager
Pernio gota de agua eje de acero con rodamiento
Шарнир "капля" со стальным штифтом с подшипником



CODE	ART.	A	C	D	E	L	S	Box info		
								Portata - Kg Capacity - Kg	Pcs per pack	Kg
11647710	564-100	48	20	Ø9	16	102	6	150	50	7,50
11647712	564-120	58	20	Ø9	16	122	6	225	40	7,0
11647714	564-140	68	25	Ø12	20	143	7	260	20	6,20
11615916	564-160	77	25	Ø12	20	161	7	300	10	4,30
11615918	564-180	86	25	Ø12	20	180	7	330	10	4,80

Finishing: Non zincato / Not galvanized

Categoria commerciale: 1E

La portata è riferita ad una coppia di cerniere nel caso di peso uniformemente distribuito in un'anta con L=H.
Weight bearing capacity refers to a pair of hinges mounted on a gate with weight uniformly distributed on a leaf with proportions L=H.

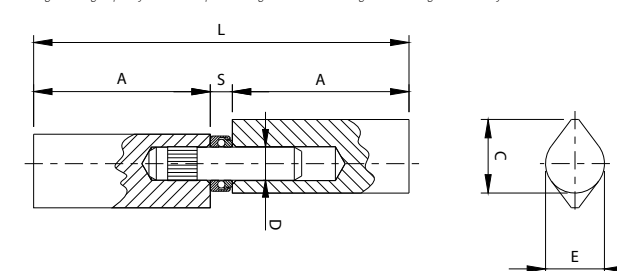

Peso uniformemente distribuito
Equally distributed weight

PERNO ZINCATO
GALVANIZED PIN

552

Maxi cerniera a 4 ali
Big hinge with 4 wings
Grande paumelle avec 4 ailes
Maxi-Schemier 4-teilig
Maxi-pernio de 4 palas
Максишарнир с 4 полками



CODE	ART.	Portata - Kg Capacity - Kg	Box info	
			Pcs per pack	Kg
11623030	552-300	1300	4	8,30

Finishing: Non zincato / Not galvanized

Categoria commerciale: 1E

La portata è riferita ad una coppia di cerniere nel caso di peso uniformemente distribuito in un'anta con L=H.
Weight bearing capacity refers to a pair of hinges mounted on a gate with weight uniformly distributed on a leaf with proportions L=H.

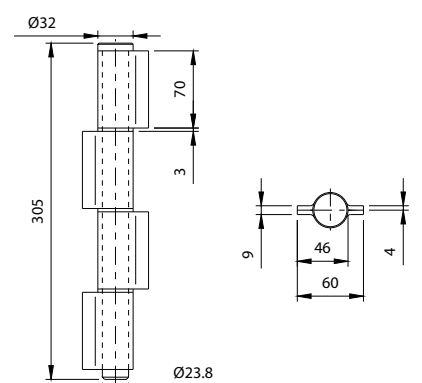

Peso uniformemente distribuito
Equally distributed weight

PERNO ZINCATO
GALVANIZED PIN



570

Cerniera "Futura" perno in acciaio
Drop hinge "Futura" with steel pin
Paumelle "Futura" avec pivot en acier
Bandrolle „Futura“ mit Zapfen aus Stahl
Pernio "Futura" eje de acero
Шарнир "Futura" стальной штифт



CODE	ART.	A	C	D	E	L	S	Box info		
								Portata - Kg Capacity - Kg	Pcs per pack	Kg
11615604	570-40	19	12	Ø6	10	40	1,5	52	40	1,20
11615606	570-60	29	12	Ø6	10	60	1,5	75	40	1,30
11615608	570-80	39	16	Ø9	13	80	2	110	40	3,30
11615610	570-100	48	16	Ø9	13	98	2	150	40	3,90
11615612	570-120	58	20	Ø9	16	119	3	225	40	7,30
11615614	570-140	68	20	Ø9	16	139	3	300	40	7,80

Finishing: Non zincato / Not galvanized

Categoria commerciale: 1E

La portata è riferita ad una coppia di cerniere nel caso di peso uniformemente distribuito in un'anta con L=H.
Weight bearing capacity refers to a pair of hinges mounted on a gate with weight uniformly distributed on a leaf with proportions L=H.

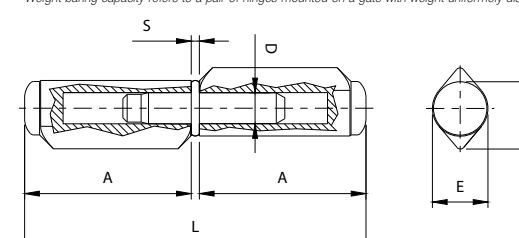

Peso uniformemente distribuito
Equally distributed weight

PERNO ZINCATO
GALVANIZED PIN



572

Cerniera "Futura" perno in ottone
Drop hinge "Futura" with brass pin
Paumelle "Futura" avec pivot en laiton
Bandrolle „Futura“ mit Zapfen aus Messing
Perno "Futura" eje de latón
Шарнир "Futura" латунный штифт



CODE	ART.	A	C	D	E	L	S	Portata - Kg Capacity - Kg	Box info	
									Pcs per pack	Kg
11616104	572-40	19	12	Ø6	10	40	1,5	30	40	1,20
11616106	572-60	29	12	Ø6	10	60	1,5	45	40	1,30
11616108	572-80	39	16	Ø9	13	80	2	75	40	3,30
11616110	572-100	48	16	Ø9	13	98	2	110	40	3,90
11616112	572-120	58	20	Ø9	16	119	3	150	40	7,30
11616114	572-140	68	20	Ø9	16	139	3	180	40	7,80

Finishing: Non zincato / Not galvanized

La portata è riferita ad una coppia di cerniere nel caso di peso uniformemente distribuito in un'anta con L=H.
Weight bearing capacity refers to a pair of hinges mounted on a gate with weight uniformly distributed on a leaf with proportions L=H.

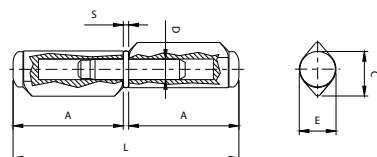

Categoria commerciale: 1E

576

Cerniera "Futura" perno rivestito in ottone con rondella
Drop hinge "Futura" with brass bearing pin and washer
Paumelle "Futura" avec pivot roulement en laiton et rondelle
Bandrolle „Futura“ mit Kugellager stift aus messing und unterlegsscheibe
Perno "Futura" eje con cojinete de latón con arandela
Шарнир "Futura" с контактный покрытием из латуни шайбой



CODE	ART.	Misura	A	C	D	E	L	S	Portata - Kg Capacity - Kg	Box info	
										Pcs per pack	Kg
11617310	576-100	22x27	45	27	Ø14	22	98	7	110	10	3,00
11617314	576-140	18x22	68	22	Ø10	18	142	6	150	16	6,10
11617315	576-150	22x27	70	27	Ø14	22	148	7	180	16	6,50

Finishing: Zincato / Galvanized

La portata è riferita ad una coppia di cerniere nel caso di peso uniformemente distribuito in un'anta con L=H.
Weight bearing capacity refers to a pair of hinges mounted on a gate with weight uniformly distributed on a leaf with proportions L=H.

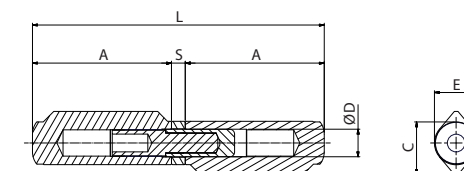

Categoria commerciale: 1E

574

Cerniera "Futura" perno in acciaio con rondella
Drop hinge "Futura" with steel pin and washer
Paumelle "Futura" avec pivot en acier et rondelle
Bandrolle „Futura“ mit Stift aus Stahl und Unterlegsscheibe
Perno "Futura" eje de acero con arandela
Шарнир "Futura" со стальным штифтом с шайбой



CODE	ART.	A	C	D	E	L	S	Portata - Kg Capacity - Kg	Box info	
									Pcs per pack	Kg
11617110	574-100	45	27	Ø14	22	98	7	150	10	3,00
11617115	574-150	70	27	Ø14	22	148	7	300	10	4,10

Finishing: Non zincato / Not galvanized

La portata è riferita ad una coppia di cerniere nel caso di peso uniformemente distribuito in un'anta con L=H.
Weight bearing capacity refers to a pair of hinges mounted on a gate with weight uniformly distributed on a leaf with proportions L=H.

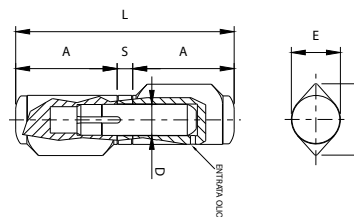

PERNO ZINCATO
GALVANIZED PIN

Categoria commerciale: 1E

577

Cerniera "Futura" perno in ottone con cuscinetto
Drop hinge "Futura" with brass pin and bearing
Paumelle "Futura" avec pivot en laiton et bague à bille
Bandrolle „Futura“ mit Stift aus Messing und Kugellager
Perno "Futura" eje de latón con rodamiento
Шарнир "Futura" с латунным штифтом с подшипником



CODE	ART.	Misura	A	C	D	E	L	S	Portata - Kg Capacity - Kg	Box info	
										Pcs per pack	Kg
11648310	577-100	22x27	45	27	Ø14	22	98	7	110	10	3,00
11648314	577-140	18x22	68	22	Ø10	18	142	6	150	10	3,80
11648315	577-150	22x27	70	27	Ø14	22	148	7	180	10	4,10

Finishing: Zincato / Galvanized

La portata è riferita ad una coppia di cerniere nel caso di peso uniformemente distribuito in un'anta con L=H.
Weight bearing capacity refers to a pair of hinges mounted on a gate with weight uniformly distributed on a leaf with proportions L=H.

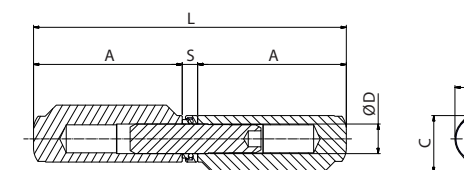

Categoria commerciale: 1E

575

Cerniera "Futura" perno in acciaio con cuscinetto
Drop hinge "Futura" with steel pin and bearing
Paumelle "Futura" avec pivot en acier et bague à bille
Bandrolle „Futura“ mit Stift aus Stahl und Kugellager
Perno "Futura" eje de acero con rodamiento
Шарнир "Futura" со стальным штифтом с подшипником



CODE	ART.	A	C	D	E	L	S	Portata - Kg Capacity - Kg	Box info	
									Pcs per pack	Kg
11617210	575-100	45	27	Ø14	22	98	7	150	10	3,00
11617215	575-150	70	27	Ø14	22	148	7	300	10	4,10

Finishing: Non zincato / Not galvanized

La portata è riferita ad una coppia di cerniere nel caso di peso uniformemente distribuito in un'anta con L=H.
Weight bearing capacity refers to a pair of hinges mounted on a gate with weight uniformly distributed on a leaf with proportions L=H.

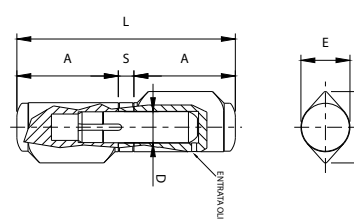

PERNO ZINCATO
GALVANIZED PIN

Categoria commerciale: 1E

577 PS

Cerniera "Futura" perno sfilabile in ottone con cuscinetto
Big hinge extractable pivot with bearing
Paumelle avec pivot en laiton et bague à bille
Big Scharnier ausziehbar Dreh mit Lager
Bisagra con perno extraíble
Большой петли извлекаемые поворота с подшипником



CODE	ART.	Portata - Kg Capacity - Kg	Box info	
			Pcs per pack	Kg
11617915	577 PS	110	10	3,00

Finishing: Non zincato / Not galvanized

La portata è riferita ad una coppia di cerniere nel caso di peso uniformemente distribuito in un'anta con L=H.
Weight bearing capacity refers to a pair of hinges mounted on a gate with weight uniformly distributed on a leaf with proportions L=H.

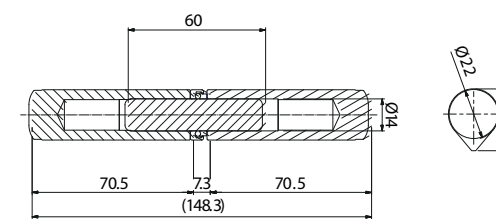

Categoria commerciale: 1E



578

Cerniera "Futura" perno rinforzato e rivestito in ottone, con cuscinetto
Drop hinge "futura" with reinforced, brass-covered pivot and bearing
Paumelle Futura avec pivot renforcé et revêtu de laiton avec roulement
Bandrolle "Futura" mit verstärktem und mit Messig beschichtetem Zapfen mit Kugellager
Perno "Futura" eje reforzado y recubierto de latón con rodamiento
Шарнир "Futura" с укрепленным штифтом с латунным покрытием с подшипником



CODE	ART.	Misura	A	D	L	Portata - Kg Capacity - Kg	Box info	
							Pcs per pack	Kg
11648410	578-100	22x27	45	Ø14	98	110	16	4,40
11648414	578-140	18x22	68	Ø10	142	150	16	4,00
11648415	578-150	22x27	70	Ø14	148	180	16	6,30

Finishing: Zincato / Galvanized

Categoria commerciale: 1E

La portata è riferita ad una coppia di cerniere nel caso di peso uniformemente distribuito in un'anta con L=H.
Weight bearing capacity refers to a pair of hinges mounted on a gate with weight uniformly distributed on a leaf with proportions L=H.

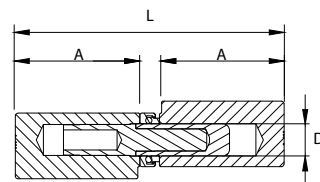

SP 497-10

Cerniera a goccia perno sfilabile in ottone con cuscinetto
Drop hinge with brass pivot with bearing
Paumelle à goutte avec pivot en laiton avec roulement
Bandrolle mit Zapfen aus Messing und Kugellager
Bisagra a gota con perno extraíble en latón con cujinetes
падение петли с латунным стержнем с подшипником



CODE	ART.	Portata - Kg Capacity - Kg	Box info	
			Pcs per pack	Kg
19912240	SP-497-100	150	16	4,3

Finishing: Zincato / Galvanized

Categoria commerciale: 1E

La portata è riferita ad una coppia di cerniere nel caso di peso uniformemente distribuito in un'anta con L=H.
Weight bearing capacity refers to a pair of hinges mounted on a gate with weight uniformly distributed on a leaf with proportions L=H.

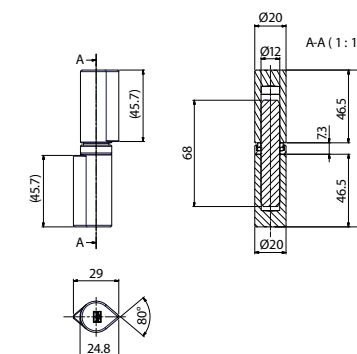

SP 495-10

Cerniera a goccia perno sfilabile in acciaio con cuscinetto
Drop hinge with steel pivot with bearing
Paumelle à goutte avec pivot en acier avec roulement
Bandrolle mit Zapfen aus Stahl und Kugellager
падение петли со стальной стержень с подшипником



CODE	ART.	Portata - Kg Capacity - Kg	Box info	
			Pcs per pack	Kg
19912001	SP-495-10	150	10	2,60

Finishing: Zincato / Galvanized

Categoria commerciale: 1E

La portata è riferita ad una coppia di cerniere nel caso di peso uniformemente distribuito in un'anta con L=H.
Weight bearing capacity refers to a pair of hinges mounted on a gate with weight uniformly distributed on a leaf with proportions L=H.

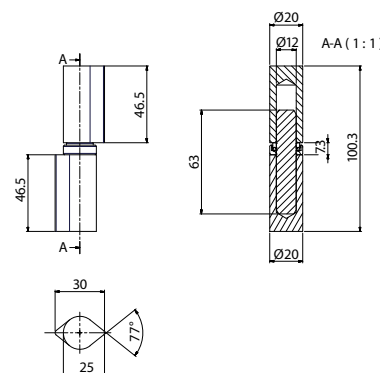

PERNO ZINCATO
GALVANIZED PIN

SP 497-15

Cerniera a goccia perno sfilabile in ottone con cuscinetto
Drop hinge with brass pivot with bearing
Paumelle à goutte avec pivot en laiton avec roulement
Bandrolle mit Zapfen aus Messing und Kugellager
Bisagra a gota con perno extraíble en latón con cujinetes
падение петли с латунным стержнем с подшипником



CODE	ART.	Portata - Kg Capacity - Kg	Box info	
			Pcs per pack	Kg
19912245	SP-497-150	250	16	5,8

Finishing: Zincato / Galvanized

Categoria commerciale: 1E

La portata è riferita ad una coppia di cerniere nel caso di peso uniformemente distribuito in un'anta con L=H.
Weight bearing capacity refers to a pair of hinges mounted on a gate with weight uniformly distributed on a leaf with proportions L=H.

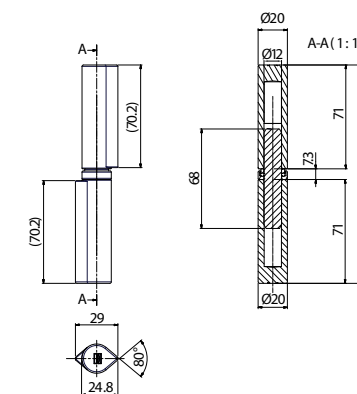

SP 495-15

Cerniera a goccia perno sfilabile in acciaio con cuscinetto
Drop hinge with steel pivot with bearing
Paumelle à goutte avec pivot en acier avec roulement
Bandrolle mit Zapfen aus Stahl und Kugellager
падение петли со стальной стержень с подшипником



CODE	ART.	Portata - Kg Capacity - Kg	Box info	
			Pcs per pack	Kg
19912005	SP-495-15	250	10	4,0

Finishing: Zincato / Galvanized

Categoria commerciale: 1E

La portata è riferita ad una coppia di cerniere nel caso di peso uniformemente distribuito in un'anta con L=H.
Weight bearing capacity refers to a pair of hinges mounted on a gate with weight uniformly distributed on a leaf with proportions L=H.

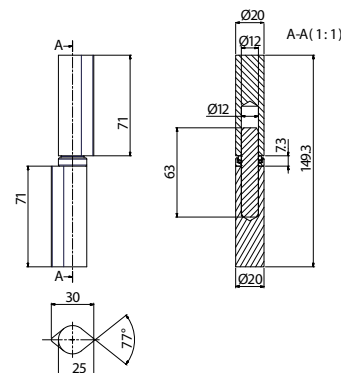

PERNO ZINCATO
GALVANIZED PIN



CHIUSURE
CLOSURES

09



73

Serratura a montaggio rapido modello "Privato"

Lock for gates "Residential" model easy to fix
Serrure pour portail modèle "Standard" au montage rapide
Schloss für Tore "Privat" Modell Einfach zum montieren
Cerradura de montaje rápido modelo "Privato"
Быстро монтирующийся замок модель "частный"



Serratura personalizzabile con logo cliente.
Lock personalized with customer's logo.

CODE	ART.	Misura	Box info	
			Pcs per pack	Kg
11210020	73-10	10	1	1,4
11210025	73-20	20	1	1,4
11210030	73-30	30	1	1,3
11210005	73-40	40	1	1,4
11210010	73-50	50	1	1,4
11210015	73-60	60	1	1,4

Categoria commerciale: 1N

CODE RAL 9005	ART.	Misura	Box info	
			Pcs per pack	Kg
11210020 503	73-10	10	1	1,3
11210025 503	73-20	20	1	1,4
11210030 503	73-30	30	1	1,3
11210005 503	73-40	40	1	1,4
11210010 503	73-50	50	1	1,4
11210015 503	73-60	60	1	1,45

Finishing: Verniciatura RAL 9005 nero / RAL 9005 black coating

Categoria commerciale: 1N

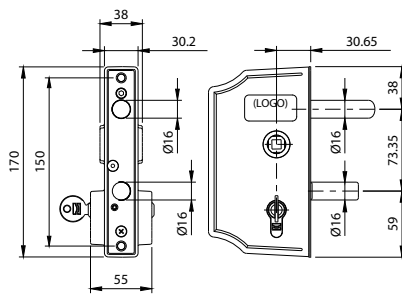

74

Serratura a montaggio rapido modello "industriale"

Lock for gates "Industrial" model easy to fix
Serrure pour portail modèle "industriel" au montage rapide
Schloss für Tore "industrie" Modell Einfach zum montieren
Cerradura de montaje rápido modelo "industrial"
Быстро монтирующийся замок модель "промышленные"



Serratura personalizzabile con logo cliente.
Lock personalized with customer's logo.

CODE	ART.	Misura	Box info	
			Pcs per pack	Kg
11210520	74-10	10	1	1,4
11210525	74-20	20	1	1,4
11210530	74-30	30	1	1,3
11210505	74-40	40	1	1,4
11210510	74-50	50	1	1,4
11210515	74-60	60	1	1,4

Categoria commerciale: 1N

CODE RAL 9005	ART.	Misura	Box info	
			Pcs per pack	Kg
11210520 503	74-10	10	1	1,3
11210525 503	74-20	20	1	1,4
11210530 503	74-30	30	1	1,3
11210505 503	74-40	40	1	1,4
11210510 503	74-50	50	1	1,4
11210515 503	74-60	60	1	1,45

Finishing: Verniciatura RAL 9005 nero / RAL 9005 black coating

Categoria commerciale: 1N

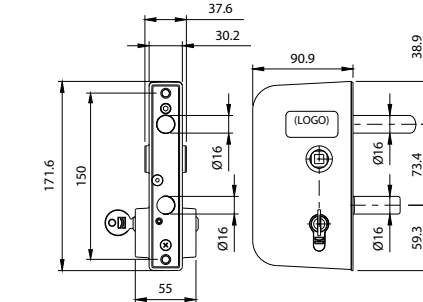

Mounting instructions art. 73

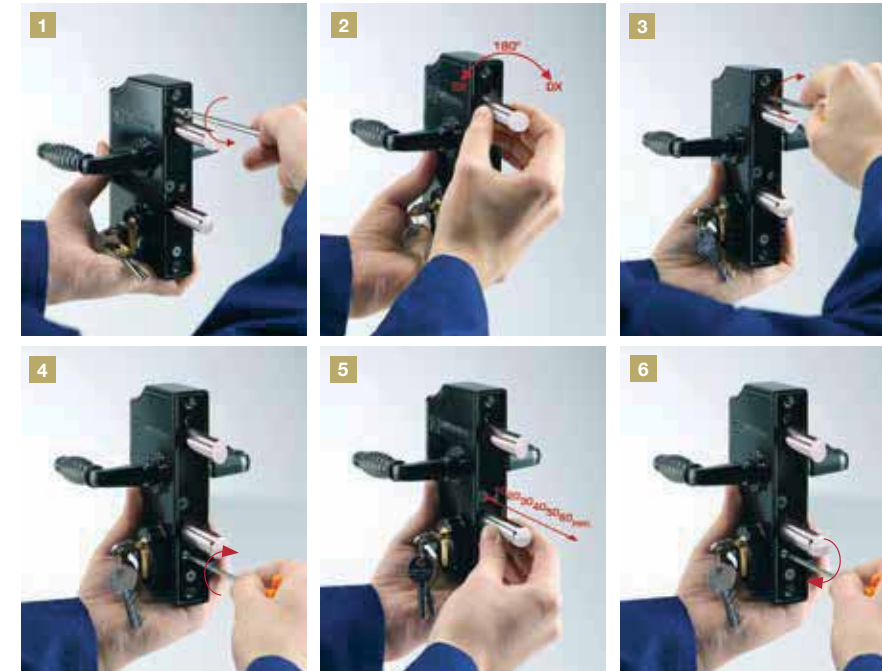
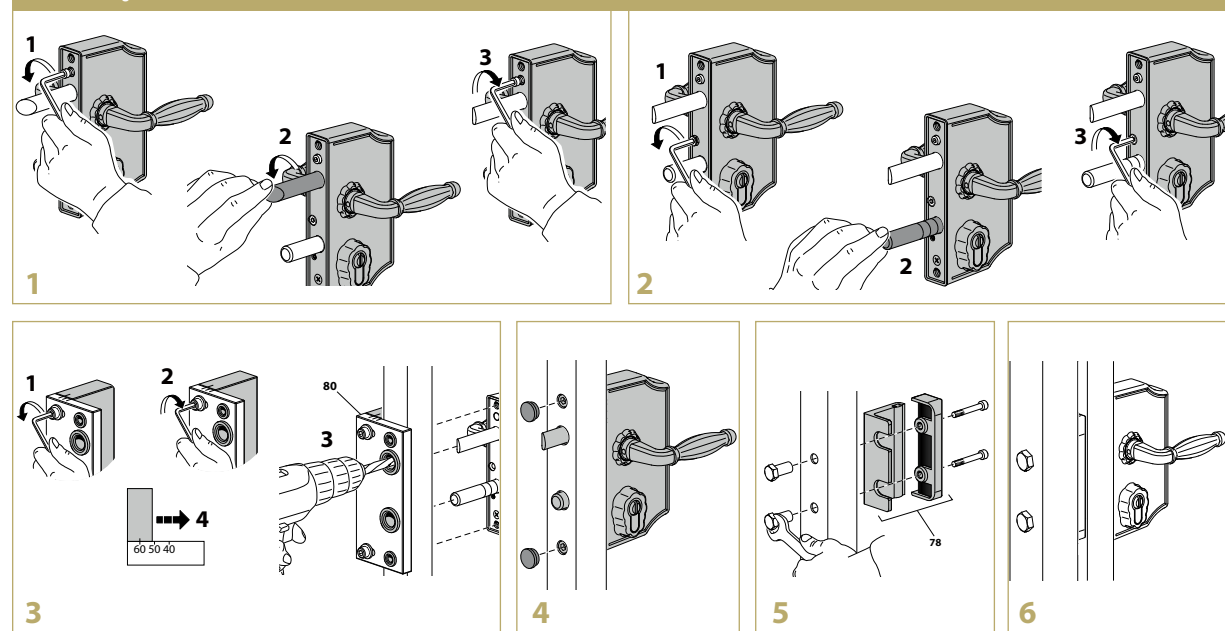

1. Svitare la vite di fissaggio / Unscrew the fixing-screw / Dévisser la vis de fixation / Schrauben Sie die Befestigungsschraube auf / Desatornillar el tornillo de fijación / Открутите фиксирующий-винт
2. Regolare lo scrocco destro-sinistro / Adjust the right or left latch / Régler le pêne demi-tour droite-gauche / Einstellen Sie di Rechts- oder Linksrichtung des Schubriegels / Regular el cerrojo derecho/izquierdo / Отрегулируйте правую или левую защелку
3. Chiudere la vite di fissaggio / Turn the fixing-screw / Fermez la vis de fixation / Ziehen Sie die Befestigungsschraube an / Cerrar el tornillo de fijación / Поверните фиксирующий-винт
4. Avvitare il grano di fissaggio / Screw the fixing-grain / Visser le grain de fixation / Schrauben Sie das Befestigungskorn an / Atomillar el tornillo prisionero de fijación / Винт фиксирующий зерна
5. Regolare lo scrocco / Adjust the latch / Régler le pêne demi-tour / Stellen Sie den Schubriegel ein / Regular el cerrojo / Отрегулируйте защелку
6. Aprire il grano di fissaggio / Open the fixing-grain / Ouvrez le grain de fixation / Machen Sie das Befestigungskorn auf / Abrir el tornillo prisionero de fijación / Откройте фиксирующий зерна



78

Incontro in alluminio per serratura art. 73 e 74

Aluminium strike for lock art. 73-74
Gâche en aluminium pour serrure art. 73-74
Schliessanschlag aus Aluminium für Schloss art. 73-74
Encuentro de aluminio para cerradura arts. 73 y 74
Стопор алюминиевый для замков арт. 73 и 74



CODE	CODE RAL 9005	ART.	Box info	
			Pcs per pack	Kg
11213505	11213505 502	78	1	0,7

Finishing: Verniciatura RAL 9005 nero / RAL 9005 black coating
Finishing: Non Zincato / Not galvanized
Categoria commerciale: 1N

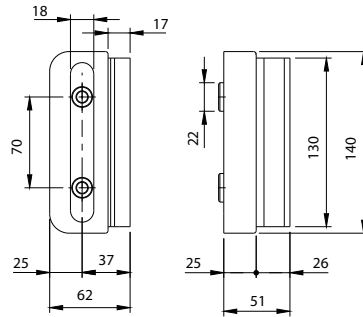

80

Dima di foratura regolabile per art. 73 e 74

Adjustable drilling fixture art. 73-74
Gabarit de perçage réglable pour art. 73-74
Einstellbare Bohrschablone art. 73-74
Plantilla de taladrado regulable para arts. 73 y 74
Шаблон для сверления регулируемый для арт. 73 и 74



CODE	ART.	R	Box info	
			Pcs per pack	Kg
11215005	80	40-60	1	4,7

Finishing: Non Zincato / Not galvanized
Categoria commerciale: 1N

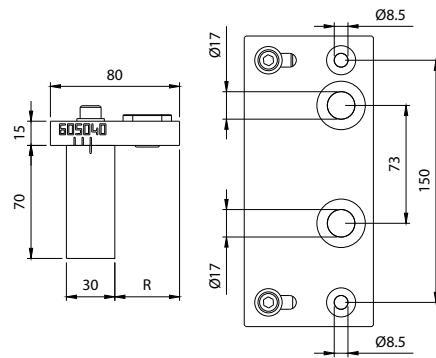

205

Maniglia in nylon

Nylon handle
Béquille en nylon
Nylon-Türdrücker
Manilla de nylon
Нейлоновая ручка



CODE	ART.	Box info	
		Pcs per pack	Kg
10900505	205	10	2,1

Finishing: Nylon
Categoria commerciale: 1H

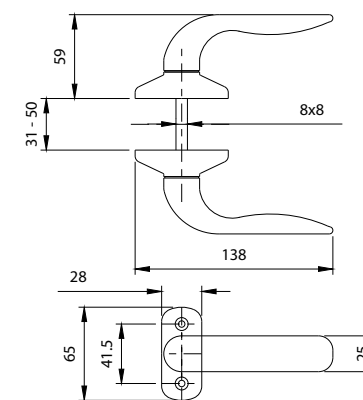

209

Maniglia in alluminio mod. "Sonia"

Aluminium handle "Sonia"
Béquille en aluminium "Sonia"
Aluminium-Türdrücker Modell "Sonia"
Manilla de aluminio mod. "Sonia"
Ручка из алюминия мод. "Sonia"



CODE RAL 9005	CODE SILVER	ART.	Box info	
			Pcs per pack	Kg
10906601 503	10906601 604	209	20	5,5

Finishing: Verniciatura RAL 9005 nero / RAL 9005 black coating
Finishing: Argento anodizzato / Silver anodized
Categoria commerciale: 1H

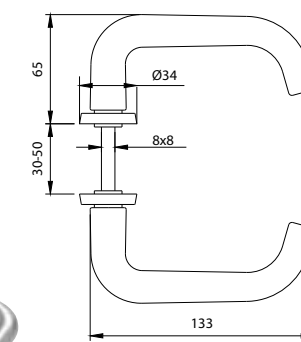

210

Maniglia in alluminio

Aluminium handle
Béquille en aluminium
Aluminium-Türdrücker
Manilla de aluminio
Ручка из алюминия



CODE RAL 9005	CODE SILVER	ART.	R	Box info	
				Pcs per pack	Kg
10901005 503	10901005 516	210-25-35	25-35	20	3,50
10901010 503	10901010 516	210-40-50	40-50	20	3,50
10901015 503	10901015 516	210-50-60	50-60	20	3,70
10901020 503	10901020 516	210-60-70	60-70	20	3,90

Finishing: Verniciatura RAL 9005 nero / RAL 9005 black coating
Finishing: Argento anodizzato / Silver anodized
Categoria commerciale: 1H

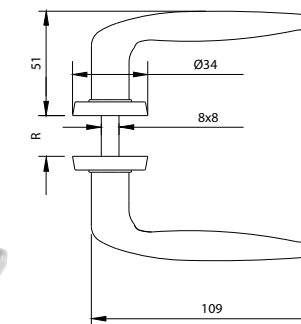

CODE SILVER

211

Maniglia in alluminio con grano

Aluminium handle with dowel
Béquille en aluminium avec grain
Aluminium-Türdrücker mit Korn
Manilla de aluminio con pasador
Ручка из алюминия с установочным винтом



CODE RAL 9005	CODE SILVER	ART.	Box info	
			Pcs per pack	Kg
10901305 503	10901305 516	211	20	4,1

Finishing: Verniciatura RAL 9005 nero / RAL 9005 black coating
Finishing: Argento anodizzato / Silver anodized
Categoria commerciale: 1H

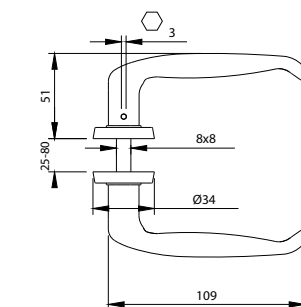

CODE SILVER



213

Maniglia in alluminio mod. "Valentina"
Aluminium handle "Valentina"
Béquille en aluminium "Valentina"
Aluminium-Türdrücker Modell "Valentina"
Manilla de aluminio mod. "Valentina"
Ручка из алюминия мод. "Valentina"



CODE	ART.	Box info	
		Pcs per pack	Kg
10905501 503	213	20	9,3

Finishing: Verniciatura RAL 9005 nero / RAL 9005 black coating

Categoria commerciale: 1H

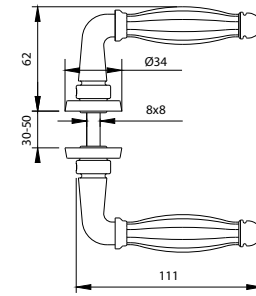

215

Serratura a gancio con cilindro
Hook-lock with cylinder
Serrure à crochet avec cylindre
Hackenschloss mit Schließzylinder
Cerradura de gancho con cilindro
Замок с крючком с цилиндром



CODE	ART.	L	Box info	
			Pcs per pack	Kg
11200501 001	215-50	50	5	6,2
11200505 001	215-60	60	5	6,2

Finishing: Zincato / Galvanized

Categoria commerciale: 1N

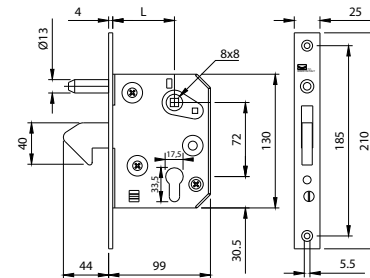

215-S

Serratura a gancio senza cilindro
Hook-lock without cylinder
Serrure à crochet sans cylindre
Hackenschloss ohne Schließzylinder
Cerradura de gancho sin cilindro
Замок с крючком без цилиндра



CODE	ART.	L	Box info	
			Pcs per pack	Kg
11200601 001	215S-50	50	5	5,3
11200605 001	215S-60	60	5	5,2

Finishing: Zincato / Galvanized

Categoria commerciale: 1N

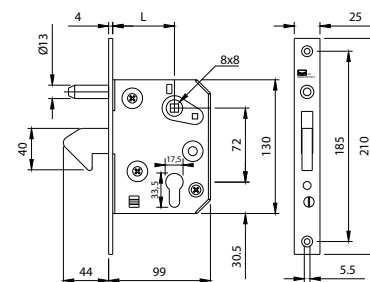

216

Contropiastra per serratura 215
Counter-plate for lock 215
Contre-platine pour serrure 215
Gegenplatte für Schloss 215
Contraplaca para cerradura 215
Контрплита для замка 215



CODE	ART.	Box info	
		Pcs per pack	Kg
11201005 001	216	25	3,5

Finishing: Zincato / Galvanized

Categoria commerciale: 1N

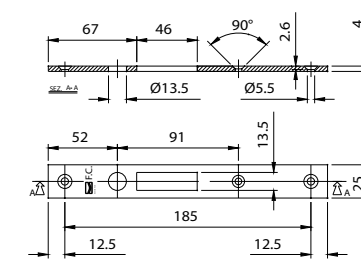

217

Incontro per serratura a gancio con
tappi ammortizzatori
End with shock absorber cups for hook-lock
Butée pour serrure à crochet avec bouchons amortisseurs
Auflauschuh für Hackenschloss mit Schlusdämpfern
Encuentro para cerradura de gancho con tapones
amortiguadores
Упор для замка с крючком с амортизирующими буферами



CODE	ART.	A	B	E	L	S	Box info	
							Pcs per pack	Kg
11201701	217-40	48	42	20	33	3	4	2,20
11201705	217-50	58	52	25	38	3	4	2,60
11201710	217-60	70	62	25	44	4	4	4,00

Finishing: Non zincato / Not galvanized

Categoria commerciale: 1G

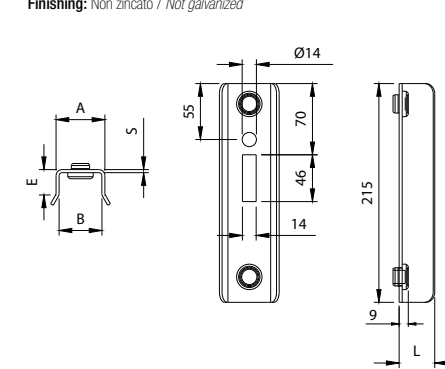

220

Copri serratura
Lock cover
Couvre serrure
Einbauschlosskasten
Cubierta de la cerradura
Крышка для замка



CODE	ART.	A	Box info	
			Pcs per pack	Kg
11202005	220-40	21	20	11,7
11202010	220-50	11	20	11,7

Finishing: Non zincato / Not galvanized

Categoria commerciale: 1G

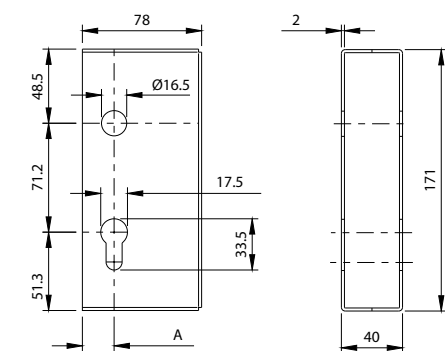



222

Serratura a gancio frontale piatto con cilindro

Plate face hook-lock with cylinder
Serrure à crochet plat avec cylindre
Hackenschloss flach mit Schließzylinder
Cerradura de gancho frontal chato con cilindro
Фронтальный плоский замок с крючком с цилиндром



CODE	ART.	A	Box info	
			Pcs per pack	Kg
11215530 001	222-30	30	5	3,20
11215535 001	222-35	35	5	3,30
11215540 001	222-40	40	5	3,40
11215545 001	222-45	45	5	3,50
11215550 001	222-50	50	5	3,60
11215560 001	222-60	60	5	3,80

Finishing: Zincato / Galvanized

Categoria commerciale: 1N

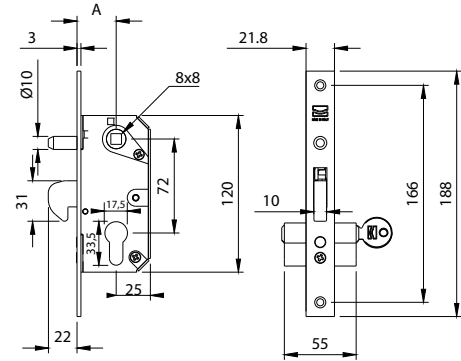

223

Serratura a gancio frontale piatto senza cilindro

Plate face hook-lock without cylinder
Serrure à crochet plat sans cylindre
Hackenschloss flach ohne Schließzylinder
Cerradura de gancho frontal chato sin cilindro
Фронтальный плоский замок с крючком без цилиндра



CODE	ART.	A	Box info	
			Pcs per pack	Kg
11215531 001	223-30	30	5	2,20
11215536 001	223-35	35	5	2,30
11215541 001	223-40	40	5	2,40
11215546 001	223-45	45	5	2,50
11215551 001	223-50	50	5	2,60
11215561 001	223-60	60	5	2,80

Finishing: Zincato / Galvanized

Categoria commerciale: 1N

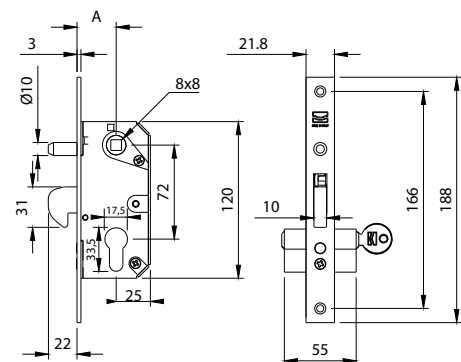

590

Piolo filettato per porte blindate

Threaded peg for armoured doors
Piquet taraudé pour portes blindées
Sicherheitsdorn mit Gewinde für gepanzerte Türen
Pivote roscada para puertas blindadas
Резьбовой кольшечек для бронированных дверей



CODE	ART.	Box info	
		Pcs per pack	Kg
10703005 001	590	100	3,10

Finishing: Zincato / Galvanized

Categoria commerciale: 1G

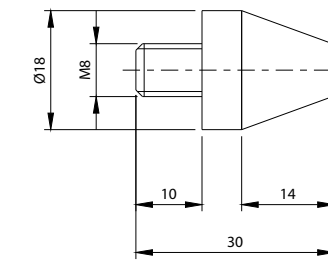

600

Cerniera per vasistas

Hinge for transom windows
Paumelle vasistas
Scharnier für Klappfenster
Bisagra para abatible
Петля для фрамуги



CODE	ART.	A	B	C	D	E	G	Box info	
								Pcs per pack	Kg
11623505	600-65	67	68	40	15	40°	27	40	4,00
11623510	600-85	90	92	53	13	48°	30	20	3,20

Finishing: Non zincato / Not galvanized

Categoria commerciale: 1G

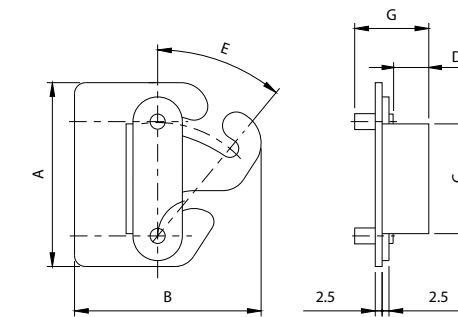

606

Cerniera a compasso per vasistas

Compass hinge for transom windows
Paumelle à compas pour vasistas
Scharnier für Klappfenster
Bisagra compás para abatible
Компасная петля для фрамуги



CODE	ART.	A	B	C	D	E	G	S	Box info	
									Pcs per pack	Kg
11624005	606-65	60	50	36	9	11	25	2	40	4,80
11624010	606-85	80	64	54	9	11	24	2,5	25	5,40

Finishing: Non zincato / Not galvanized

Categoria commerciale: 1G

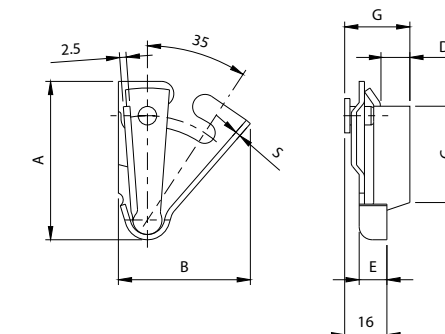



615

Copri angolo per finestre
Cover-angle for windows
Couvre-coin pour fenêtres
Winkelbedeckung für Fenster
Cubre-esquina para ventanas
Уголок для окон

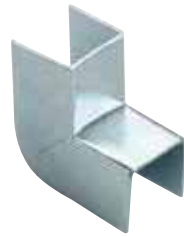

CODE	ART.	A	B	R	Box info	
					Pcs per pack	Kg
12207505 001	615-10	24	10	6	500	3,00
12207510 001	615-12	26	12	9	500	3,50

Finishing: Zincato / Galvanized

Categoria commerciale: 1G

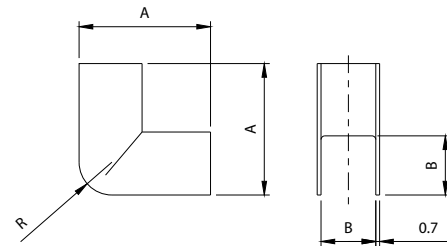

625

Chiavetta in zama
Zinked key
Clé en zamac
Schlüssel aus Zamac
Llave de zamac
Ключик замат



CODE	ART.	Pcs per pack	Box info	
			Pcs per pack	Kg
11701005 001	625 □	50	50	1,1
11701010 001	625 △	50	50	1,2

Finishing: Zincato / Galvanized

Categoria commerciale: 1G

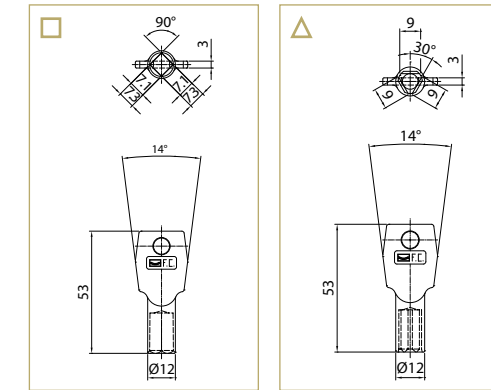

620

Chiavistello Zincato
Galvanized latch
Verrou zingué
Verzinkter Riegel
Cerrojo Galvanizado
Оцинкованный засов



CODE	ART.	Box info	
		Pcs per pack	Kg
11700505 001	620	50	2,1

Finishing: Zincato / Galvanized

Categoria commerciale: 1G

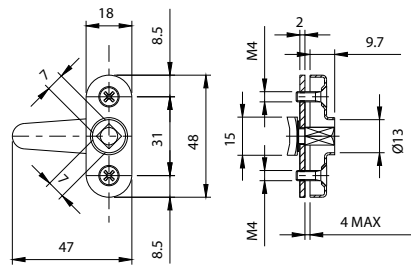

627

Chiavistello a leva zincato
Galvanized lever latch
Verrou à levier zingué
Riegel mit Hebel verzinkt
Cerrojo con maneta galvanizado
Засов с рычагом оцинкованный



CODE	ART.	A	B	C	D	E	F	G	H	I	J	K	L	M	Box info	
															Pcs per pack	Kg
11701105 001	627P	63,5	12,5	2	6,5	3,5	18	5,5	9	8	18	34	81	101	20	1,3
11701110 001	627G	76	15	2,5	7,3	4	27	6,5	13,5	8	24	46	101,5	126	20	2,7

Finishing: Zincato / Galvanized

Categoria commerciale: 1G

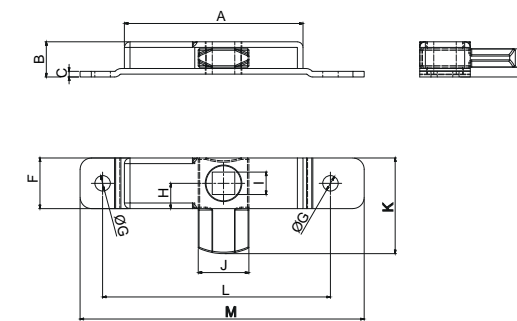

620i

Chiavistello inox
Stainless steel latch
Verrou inox
Riegel aus Edelstahl
Cerrojo Acero Inox
Засов из нержавеющей стали



CODE	ART.	Box info	
		Pcs per pack	Kg
11700595	620i	50	2,1

Finishing: Inox / Stainless steel

Categoria commerciale: 2G

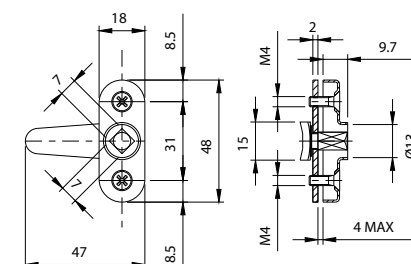

628

Chiave in alluminio per chiavistello
Art.627
Aluminium key for latch
Clé en aluminium pour verrou
Aluminium Schlüssel für Riegel
Llave en latón para cerrojo
Алюминий ключ для защелки



CODE	ART.	Size	Portata Capacity	Box info	
				Pcs per pack	Kg
11701205	628	Piccolo Ø 24	30 kg	20	1,2

Finishing: Non zincato / Not Galvanized

Categoria commerciale: 1G

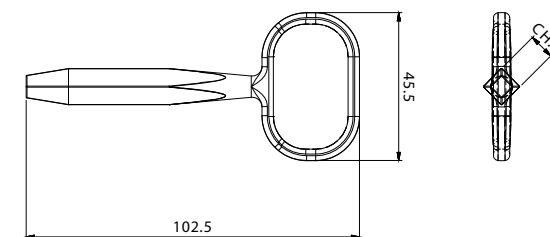



630

Cricchetto per vasistas
Catch for transom windows
Loqueteau pour vasistas
Schnappschluss für Klappfenster
Cierre para abatible
Собака для фрамуги



CODE	ART.	Box info	
		Pcs per pack	Kg
11701505 001	630	50	3,5

Finishing: Zincato / Galvanized

Categoria commerciale: 1G

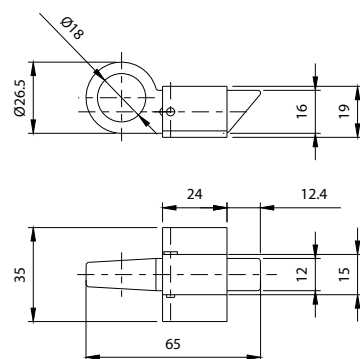

645

Ferrogliera per art. 630
Staple for art.630
Gâche pour art.630
Befestigungsklammer für Art. 630
Cerradero para art. 630
Скоба для арт. 630

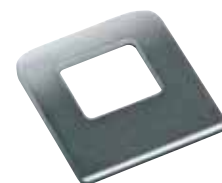

CODE	ART.	Box info	
		Pcs per pack	Kg
11703005	645	200	4,8

Finishing: Non zincato / Not galvanized

Categoria commerciale: 1G

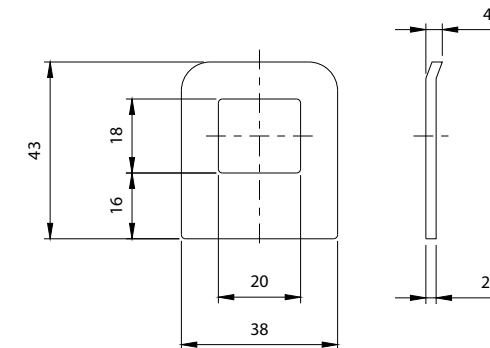

635

Cricchetto per vasistas
Catch for transom windows
Loqueteau pour vasistas
Schnappschluss für Klappfenster
Cierre para abatible
Собака для фрамуги



CODE	ART.	Box info	
		Pcs per pack	Kg
11702005	635	50	4,1

Finishing: Non zincato / Not galvanized

Categoria commerciale: 1G

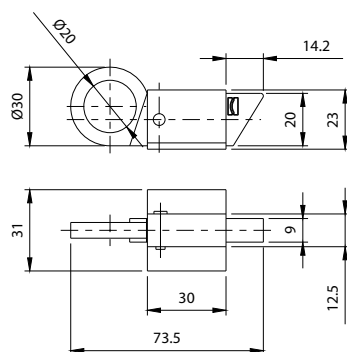

650

Ferrogliera per art. 630 - 635 - 640
Staple for art.630 -635-640
Gâche pour art.630-635-640
Befestigungsklammer für Art. 630-635-640
Cerradero para arts. 630 - 635 - 640
Скоба для арт. 630 - 635 - 640



CODE	ART.	Box info	
		Pcs per pack	Kg
11703505	650	200	6,2

Finishing: Non zincato / Not galvanized

Categoria commerciale: 1G

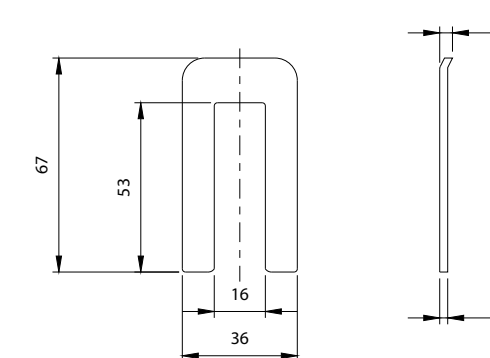

640

Cricchetto per vasistas
Catch for transom windows
Loqueteau pour vasistas
Schnappschluss für Klappfenster
Cierre para abatible
Собака для фрамуги



CODE	ART.	Box info	
		Pcs per pack	Kg
11702505	640	25	4,1

Finishing: Non zincato / Not galvanized

Categoria commerciale: 1G

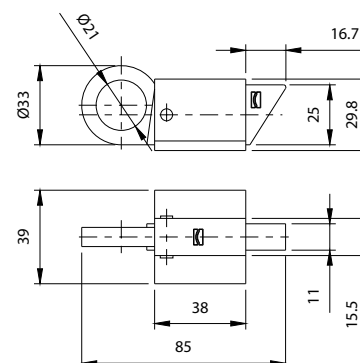

655

Ferrogliera per art. 630 - 635 - 640
Staple for art.630 -635-640
Gâche pour art.630-635-640
Befestigungsklammer für Art. 630-635-640
Cerradero para arts. 630 - 635 - 640
Скоба для арт. 630 - 635 - 640



CODE	ART.	Box info	
		Pcs per pack	Kg
11704005	655	200	3,6

Finishing: Non zincato / Not galvanized

Categoria commerciale: 1G

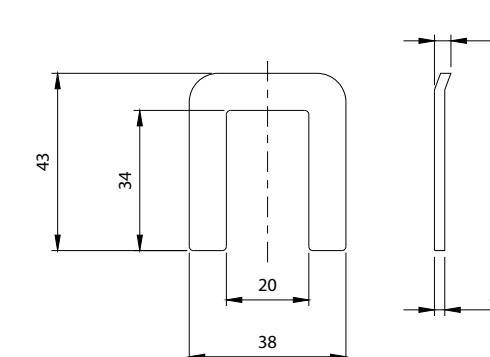



660

Maniglia a blocco
Lever bolt
Poignée de blocage
Fensterverschluss
Manilla de bloqueo
Ручка с блокировкой



CODE	ART.	Box info	
		Pcs per pack	Kg
10904005 001	660DX	20	3,0
10904010 001	660SX	20	3,0

Finishing: Zincato / Galvanized

Categoria commerciale: 1H

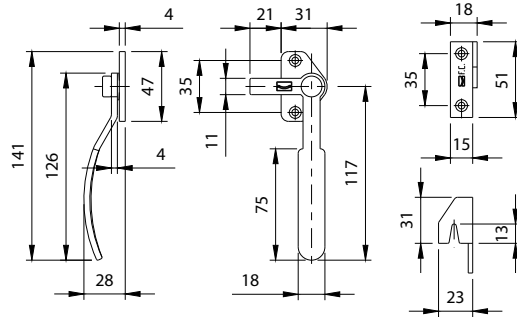

662

Maniglia a blocco reversibile
Reversible lever bolt
Poignée de blocage réversible
Fensterverschluss doppelseitig
Manilla de bloqueo reversible
Реверсивная ручка с блокировкой



CODE	ART.	Box info	
		Pcs per pack	Kg
10904505 001	662	20	4,5

Finishing: Zincato / Galvanized

Categoria commerciale: 1H

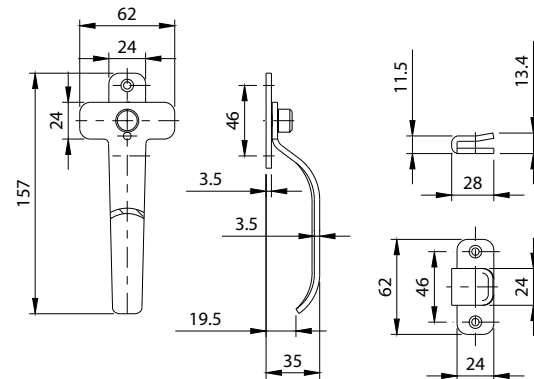

700Z

Catenaccio ad incasso doppia mandata leva ottone
Flush mounted bolt with 2 locking and brass lever
Verrou à bascule avec 2 sorties et levier bichromaté
Kantenriegel mit Doppel-Bewegung und Hebel aus Messing
Pasador doble de embutir manilla de latón
Цель встраиваемая двойная рычаг из латуни



CODE	ART.	Corsa Rod stroke	Box info	
			Pcs per pack	Kg
11901005 001	700Z	13	10	3,20

Finishing: Zincato / Galvanized

Categoria commerciale: 1D

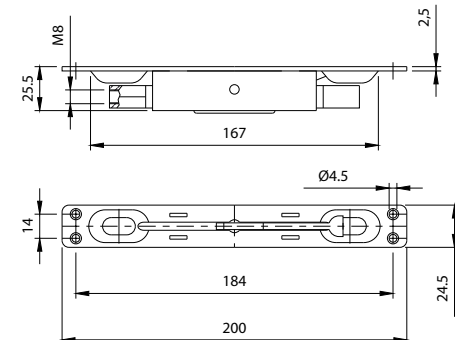

704

Catenaccio ad incasso una mandata leva zincata
Flush mounted bolt with 1 locking, galvanised lever
Verrou à bascule avec 1 sortie et levier zingué
Kantenriegel mit Einzel-Bewegung und Hebel verzinkt
Cerrojo empotrado para bloquear la puerta al cerrarse, barra galvanizada
Цель встраиваемая одинарная рычаг из Оцинкованная



CODE	ART.	A	B	C	D	Corsa Rod stroke	Box info	
							Pcs per pack	Kg
11901206 001	704-16	155	16	141	-	16	20	2,00
11901211 001	704-20	155	20	141	11	16	20	2,20
11901216 001	704-24	160	24	146	14	16	20	2,40
11901215 001	704-24 leva ottone/lever brass	160	24	146	14	16	20	2,40

Finishing: Zincato / Galvanized

Categoria commerciale: 1D

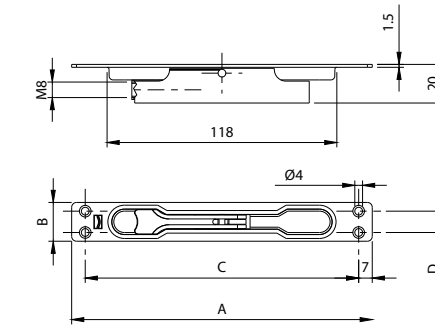

705

Catenaccio ad incasso una mandata leva ottone
Flush mounted bolt with 1 locking, brass lever
Verrou à bascule avec 1 sortie et levier bichromaté
Kantenriegel mit Einzel-Bewegung und Hebel aus Messing
Pasador de embutir manilla de latón
Цель встраиваемая одинарная рычаг из латуни



CODE	ART.	A	B	C	D	Corsa Rod stroke	Box info	
							Pcs per pack	Kg
11901605 001	705-16	155	16	141	-	16	20	2,00
11901610 001	705-20	155	20	141	11	16	20	2,20
11901615 001	705-24	160	24	146	14	16	20	2,40

Finishing: Zincato / Galvanized

Categoria commerciale: 1D

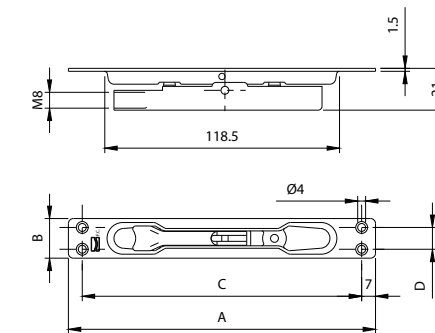



706

Catenaccio per porte blindate una mandata leva ottone nichelato corsa 30 mm

Flush mounted bolt for armoured doors with 1 locking and nickel-plate brass lever stroke 30 mm
Verrou à bascule pour portes blindées avec 1 sortie et levier en laiton nickelé course 30 mm
Kantenriegel für gepanzerte Türe mit Einzel-Bewegung und Hebel aus nickelplattiertem Messing 30 mm Hub
Pasador para puertas blindadas manilla de latón niquelado carrera 30 mm
Цепь для бронированных дверей одинарная рычаг из латуни никелированный ход 30 мм



CODE	ART.	Corsa Rod stroke	Box info	
			Pcs per pack	Kg
11901805 001	706	30	6	1,8

Finishing: Zincato / Galvanized

Categoria commerciale: 1D

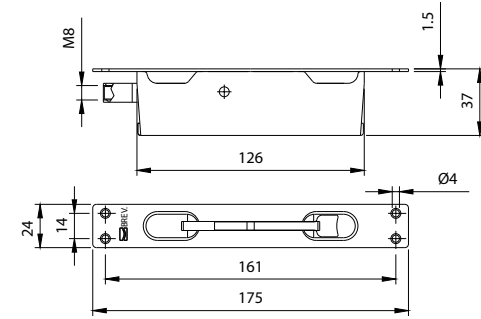

710

Catenaccio punta quadrata \square 10

Square bolt
Verrou carré
Stangenriegel mit viereckiger Spitze
Pasador punta cuadrada 10
Цепь с квадратным наконечником 10

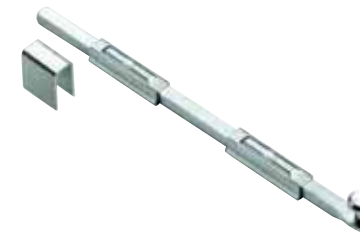

CODE	ART.	L	Box info	
			Pcs per pack	Kg
11902005 001	710-130	130	10	2,00
11902010 001	710-300	300	10	3,90
11902015 001	710-500	500	10	6,00

Finishing: Zincato / Galvanized

Categoria commerciale: 1D

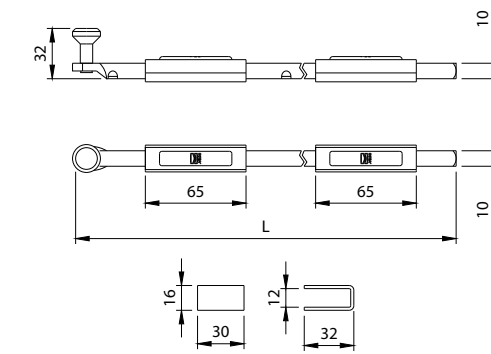

707

Catenaccio per porte blindate doppia mandata leva ottone nichelato corsa 15 mm

Flush mounted bolt for armoured doors with 2 lockings and nickel-plate brass lever stroke 15 mm
Verrou à bascule pour portes blindées avec 2 sorties et levier en laiton nickelé course 15 mm
Kantenriegel für gepanzerte Türe mit Doppel-Bewegung und Hebel aus nickelplattiertem Messing 15 mm Hub
Pasador doble para puertas blindadas manilla de latón niquelado carrera 15 mm
Цепь для бронированных дверей двойная рычаг из латуни никелированный ход 15 мм



CODE	ART.	Corsa Rod stroke	Box info	
			Pcs per pack	Kg
11901905 001	707	15	6	2,1

Finishing: Zincato / Galvanized

Categoria commerciale: 1D

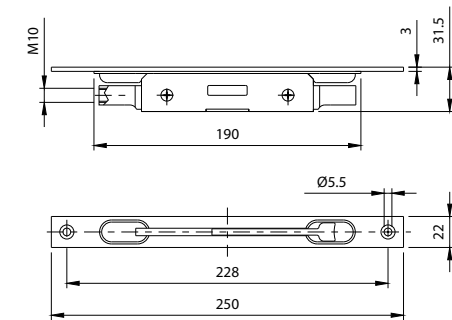

712

Catenaccio punta tonda \varnothing 10

Round bolt
Verrou avec pointe ronde
Stangenriegel mit runder Spitze
Pasador punta redonda \varnothing 10
Цепь с круглым наконечником \varnothing 10

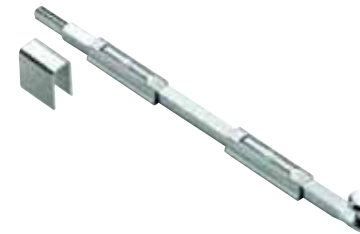

CODE	ART.	L	Box info	
			Pcs per pack	Kg
11902505 001	712-130	130	10	2,00
11902510 001	712-300	300	10	3,90
11902515 001	712-500	500	10	6,00

Finishing: Zincato / Galvanized

Categoria commerciale: 1D

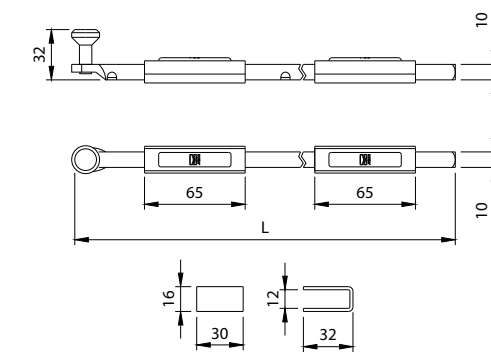

708

Catenaccio per porte blindate doppia mandata leva ottone nichelato corsa 21 mm

Flush mounted bolt for armoured doors with 2 lockings and nickel-plate brass lever stroke 21 mm
Verrou à bascule pour portes blindées avec 2 sorties et levier en laiton nickelé course 21 mm
Kantenriegel für gepanzerte Türe mit Doppel-Bewegung und Hebel aus nickelplattiertem Messing 21 mm Hub
Pasador doble para puertas blindadas manilla de latón niquelado carrera 21 mm
Цепь для бронированных дверей двойная рычаг из латуни никелированный ход 21 мм



CODE	ART.	Corsa Rod stroke	Box info	
			Pcs per pack	Kg
11901705 001	708	21	6	2,9

Finishing: Zincato / Galvanized

Categoria commerciale: 1D

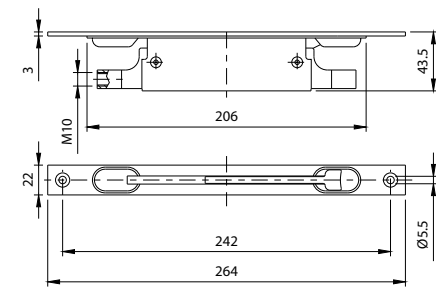

714

Catenaccio punta quadrata \square 14

Square bolt
Verrou avec pointe carrée
Stangenriegel mit viereckiger Spitze
Pasador punta cuadrada 14
Цепь с квадратным наконечником 14



CODE	ART.	L	Box info	
			Pcs per pack	Kg
11903005 001	714-330	330	5	3,70
11903010 001	714-660	660	5	6,50

Finishing: Zincato / Galvanized

Categoria commerciale: 1D

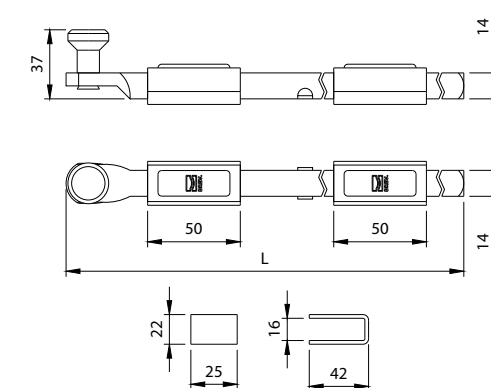



716

Catenaccio punta tonda Ø14

Round bolt
Verrou avec pointe ronde
Stangenriegel mit runder Spitze
Pasador punta redonda Ø 14
Цепь с круглым наконечником Ø 14



CODE	ART.	L	Box info	
			Pcs per pack	Kg
11903505 001	716-330	330	5	3,70
11903510 001	716-660	660	5	6,50

Finishing: Zincato / Galvanized

Categoria commerciale: 1D

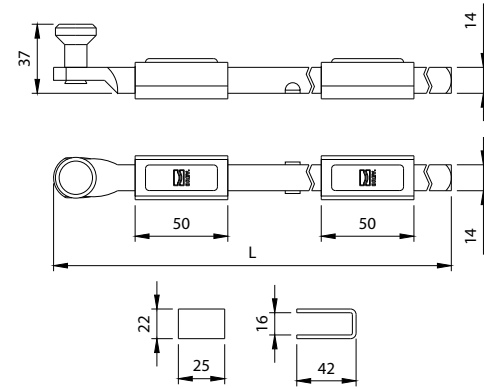

725

Catenaccio a leva pesante

Heavy bolt with lever
Verrou lourd à levier
Stangenriegel mit großem Hebel
Pasador de manilla pesado
Тяжелая цепь с рычагом



CODE	ART.	L	Box info	
			Pcs per pack	Kg
11904505 001	725-450	450	10	7,80
11904510 001	725-600	600	10	9,70
11904515 001	725-800	800	10	12,20

Finishing: Zincato / Galvanized

Categoria commerciale: 1D

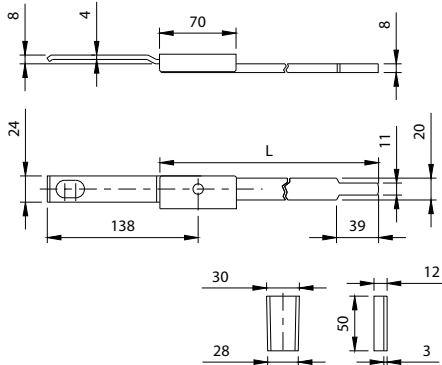

730i

Catenaccio autobloccante da avvitare punta tonda Ø12 Corsa 30mm

Self-locking bolt to be screwed with rod Ø 12 Stroke 30mm
Verrou autobloquant à visser avec pointe ronde Ø 12 Course 30mm
Selbstsperrender Stangenriegel zum Anschrauben mit Stange Ø 12 Hub 30mm
Pasador autobloccante para atornillar punta redonda Ø12 Carrera 30 mm
Навинчивающаяся самоблокирующаяся цепь с круглым наконечником Ø12 ход 30 мм



CODE	ART.	Box info	
		Pcs per pack	Kg
11912001	730i	4	1,60

Finishing: Inox / Stainless steel

Categoria commerciale: 2D

720

Catenaccio a leva punta arrotondata

Round-pointed bolt with lever
Verrou à levier avec pointe arrondie
Stangenriegel mit abgerundetem Hebelspitze
Pasador de manilla punta redondeada
Цепь с рычагом с круглым наконечником

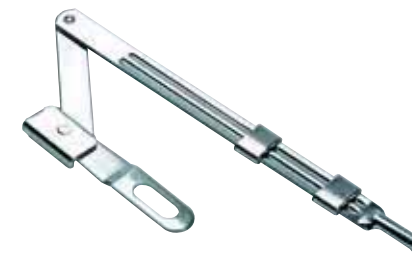

CODE	ART.	G	L	Box info	
				Pcs per pack	Kg
11904005 001	720-350	230	350	10	3,20
11904010 001	720-450	330	450	10	3,70
11904015 001	720-600	470	600	10	4,40
11904020 001	720-800	670	800	10	5,40

Finishing: Zincato / Galvanized

Categoria commerciale: 1D

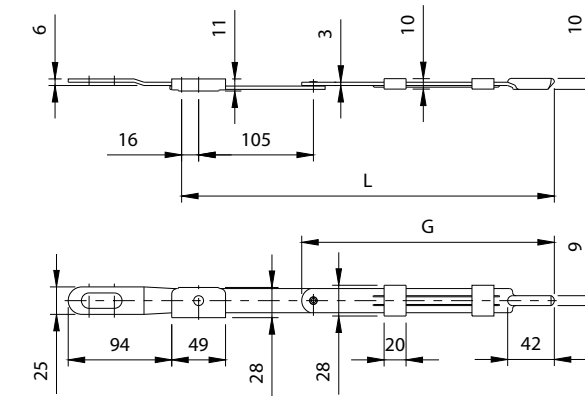

Mounting instructions art. 720

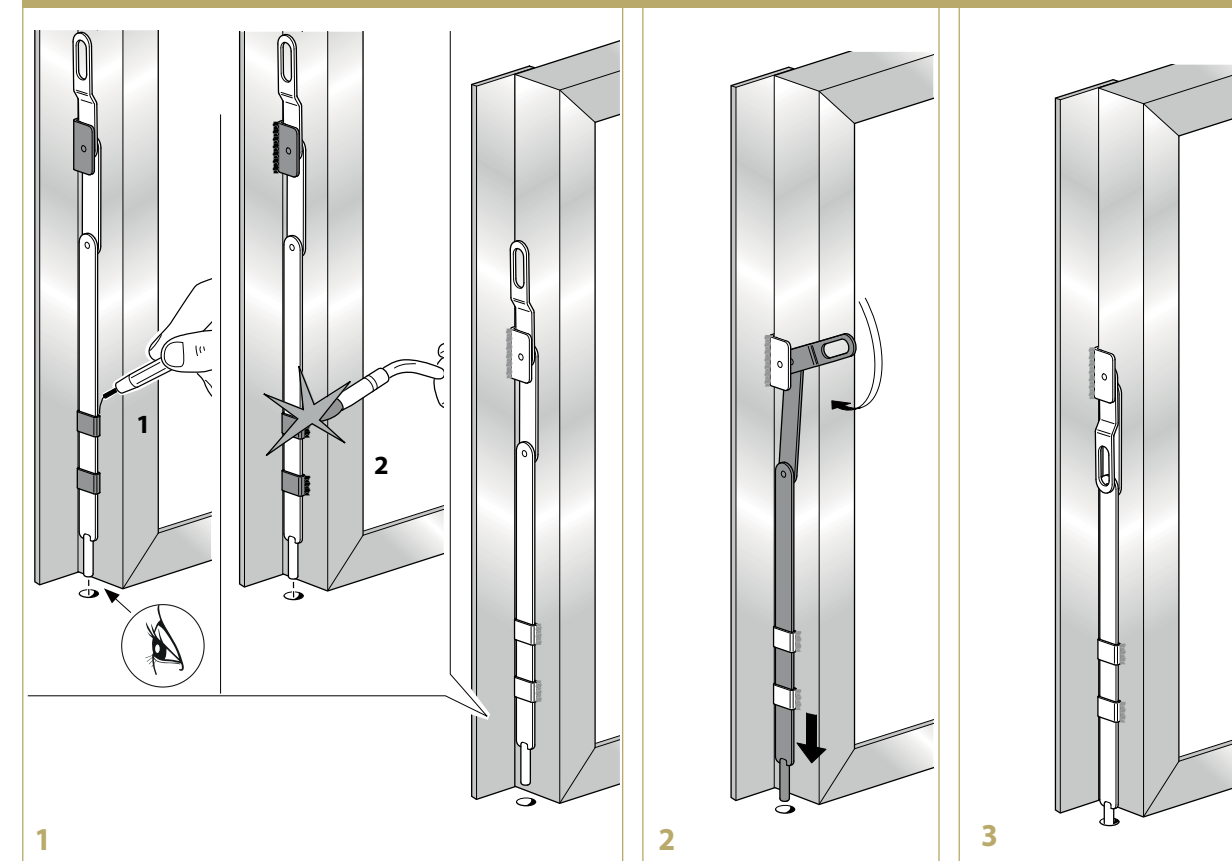



735

Catenaccio medio a saldare
Medium bolt to be welded
Verrou moyen à souder
Stangenriegel zum Anschweißen medium
Pasador mediano para soldar
Средняя привариваемая цепь



CODE	ART.	C	L	Box info	
				Pcs per pack	Kg
11905005 001	735-150	150	200	10	2,00
11905010 001	735-200	200	250	10	2,60
11905015 001	735-250	250	300	10	3,20
11905020 001	735-300	300	350	10	3,90
11905025 001	735-400	400	450	10	5,20
11905030 001	735-500	500	550	10	6,40
11905035 001	735-600	600	650	10	7,10
11905040 001	735-800	800	850	10	10,20

Finishing: Zincato / Galvanized

Categoria commerciale: 1D

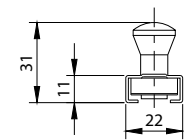
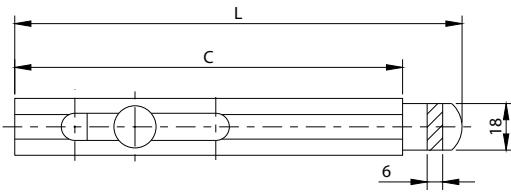

740

Catenaccio leggero ∇ 14mm
Light bolt
Verrou léger
Kleiner Stossriegel
Pasador ligero 14 mm
Легкая цепь 14 мм



CODE	ART.	C	L	Box info	
				Pcs per pack	Kg
11905505 001	740-150	150	190	10	1,80
11905510 001	740-200	200	240	10	2,20
11905515 001	740-250	250	290	10	2,80
11905520 001	740-300	300	340	10	3,30
11905525 001	740-400	400	440	10	4,40
11905530 001	740-500	500	540	10	5,40
11905535 001	740-600	600	640	10	6,60
11905540 001	740-800	800	840	10	8,50

Finishing: Zincato / Galvanized

Categoria commerciale: 1D

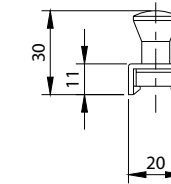
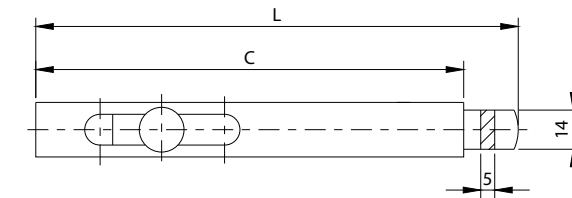

737

Catenaccio a saldare asta
tonda \varnothing 12mm
Bolt to be welded round bar dia. 12mm
Verrou à souder tringle ronde dia. 12mm
Stossriegel mit abgerundeter Stange
zum Anschweißen
Pasador para soldar varilla redonda \varnothing 12 mm
Привариваемая цепь круглый стержень \varnothing 12 мм



CODE	ART.	C	L	Box info	
				Pcs per pack	Kg
11905205 001	737-150	150	190	10	2,30
11905210 001	737-200	200	255	10	3,00
11905215 001	737-250	250	305	10	3,80
11905220 001	737-300	300	355	10	4,50
11905225 001	737-400	400	455	10	6,00
11905230 001	737-500	500	555	10	6,50
11905235 001	737-600	600	655	10	9,10
11905240 001	737-800	800	855	10	12,20

Finishing: Zincato / Galvanized

Categoria commerciale: 1D

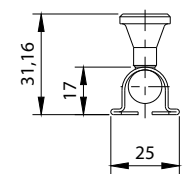
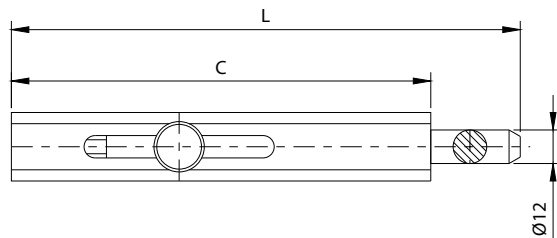

745

Catenaccio pesante ∇ 25mm
Heavy bolt
Verrou lourd
Grosser Stossriegel
Pasador pesado 25 mm
Тяжелая цепь 25 мм

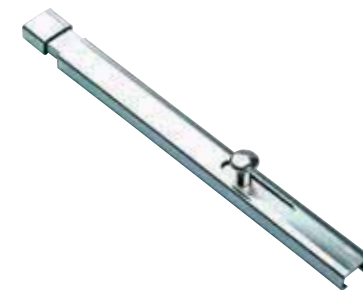

CODE	ART.	C	L	Box info	
				Pcs per pack	Kg
11906005 001	745-200	200	250	6	3,50
11906010 001	745-250	250	300	6	4,50
11906015 001	745-300	300	350	6	5,20
11906020 001	745-400	400	450	6	6,80
11906025 001	745-500	500	550	6	8,50
11906030 001	745-600	600	650	6	10,20
11906035 001	745-800	800	850	6	13,30

Finishing: Zincato / Galvanized

Categoria commerciale: 1D

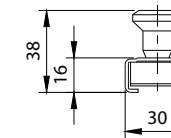
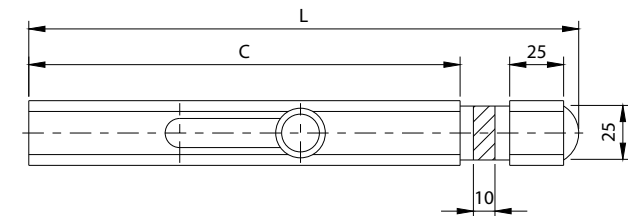



750

Catenaccio porta lucchetto medio

16mm

Medium padlock-bolt
Verrou porte-cadenas moyen
Hangschlossriegel medium
Pasador portacandado mediano 16 mm
Цепь для замка средняя 16 мм



CODE	ART.	C	I	L	Box info	
					Pcs per pack	Kg
11906505 001	750-150	115	81	163	10	2,70
11906510 001	750-200	165	131	213	10	3,30

Finishing: Zincato / Galvanized

Categoria commerciale: 1D

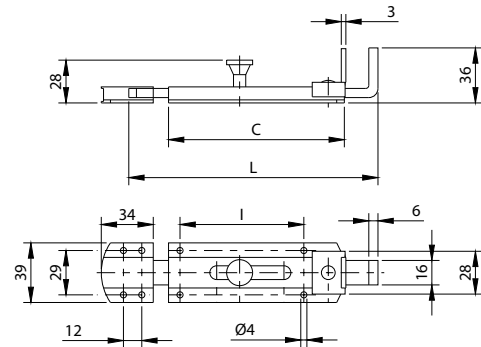

752

Catenaccio porta lucchetto asta
tonda Ø12

Padlock-bolt with round rod
Verrou porte-cadenas tringle ronde
Hangschlossriegel mit abgerundeter Stange
Pasador portacandado varilla redonda Ø 12
Цепь для замка круглый стержень Ø 12



CODE	ART.	A	C	I	L	Box info	
						Pcs per pack	Kg
11906705 005	752-130	40	130	72,5	173	10	3,10
11906710 005	752-145	65	145	87,5	216	10	3,80
11906715 005	752-170	90	170	112,5	263	10	4,60
11906720 005	752-195	115	195	137,5	313	10	5,51

Finishing: Bronzato / Bronze plated

Categoria commerciale: 1D

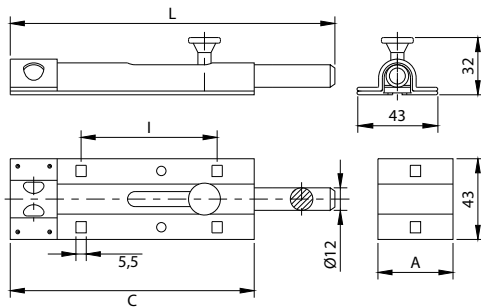

755

Catenaccio porta lucchetto pesante

25mm

Heavy padlock-bolt
Verrou porte-cadenas lourd
Hangschlossriegel gross
Pasador portacandado pesado 25 mm
Цепь для замка тяжелая 25 мм



CODE	ART.	B	C	I	L	M	Box info	
							Pcs per pack	Kg
11907005 001	755-200	65	135	84	215	31,5	4	3,40
11907010 001	755-300	65	230	179	310	35,1	4	4,80
11907015 001	755-400	100	300	249	410	68,5	4	6,00
11907020 001	755-500	100	400	349	510	68,5	4	7,50

Finishing: Zincato / Galvanized

Categoria commerciale: 1D

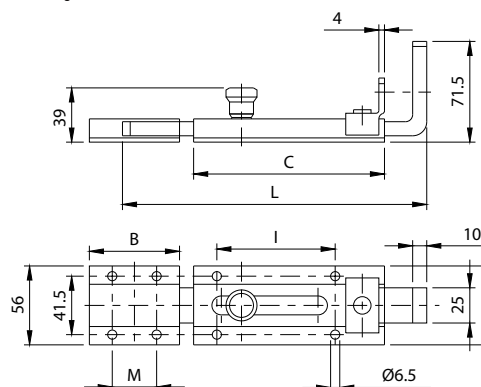

760

Catenaccio porta lucchetto asta
tonda Ø14

Padlock-bolt with round rod d. 14 mm
Verrou porte-cadenas tringle ronde dia. 14mm
Hangschlossriegel mit abgerundeter Stange d. 14 mm
Pasador portacandado varilla redonda Ø 14
Цепь для замка круглый стержень Ø 14



CODE	ART.	B	C	I	L	M	Box info	
							Pcs per pack	Kg
11907505 001	760-180	53,5	137	50,5	155	35	10	4,20
11907510 001	760-215	62	159	59	194,5	40	10	4,90
11907515 001	760-270	87	183	73,5	246	70	10	6,10

Finishing: Zincato / Galvanized

Categoria commerciale: 1D

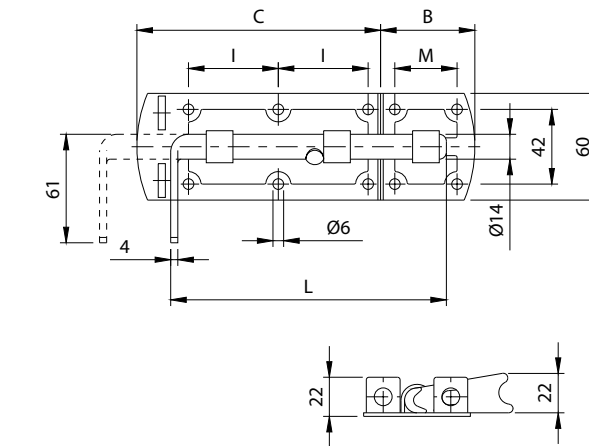

800

Catenaccio ad avvitare 18mm

Bolt to be screwed
Verrou à visser
Stossriegel zum Anschrauben
Pasador para atornillar 18 mm
Навинчивающаяся цепь 18 мм



CODE	ART.	C	L	Box info	
				Pcs per pack	Kg
11908005 001	800-200	200	230	10	2,30
11908010 001	800-250	250	280	10	2,90
11908015 001	800-300	300	330	10	3,60
11908020 001	800-400	400	430	10	4,80
11908025 001	800-500	500	530	10	6,00
11908030 001	800-600	600	630	10	7,20
11908035 001	800-800	800	830	10	9,70

Finishing: Zincato / Galvanized

Categoria commerciale: 1D

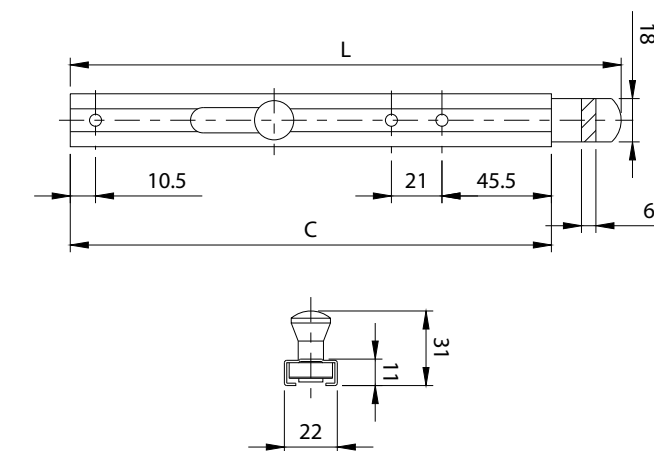



805

Catenaccio trasversale leggero

☒ 16mm

Transverse light bolt
Verrou transversal léger
Horizontalstossriegel klein
Pasador transversal ligero 16 mm
Легкая поперечная цепь 16 мм



CODE	ART.	B	C	I	L	M	Box info	
							Pcs per pack	Kg
11908505 005	805-80	25	55	33	77	-	10	1,20
11908510 005	805-120	42	79	57	119	19	10	1,70
11908515 005	805-160	60	99	77	157	37	10	2,30
11908520 005	805-200	80	120	97	198	57	10	2,80

Finishing: Bronzato / Bronze plated

Categoria commerciale: 1D

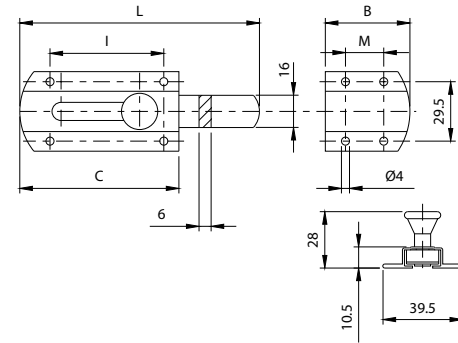

825

Catenaccio verticale medio

☒ 16mm

Vertical bolt
Verrou vertical moyen
Vertikaler Stossriegel medium
Pasador vertical mediano 16 mm
Средняя вертикальная цепь 16 мм



CODE	ART.	C	I	L	Box info	
					Pcs per pack	Kg
11910005 005	825-150	150	127	190	10	2,10
11910010 005	825-200	200	177	240	10	2,80
11910015 005	825-250	250	227	290	10	3,60
11910020 005	825-300	300	277	340	10	4,10
11910025 005	825-400	400	385	440	10	5,60
11910030 005	825-500	500	490	540	10	5,90
11910035 005	825-600	600	593	640	10	8,20
11910040 005	825-800	800	793	840	10	11,10

Finishing: Bronzato / Bronze plated

Categoria commerciale: 1D

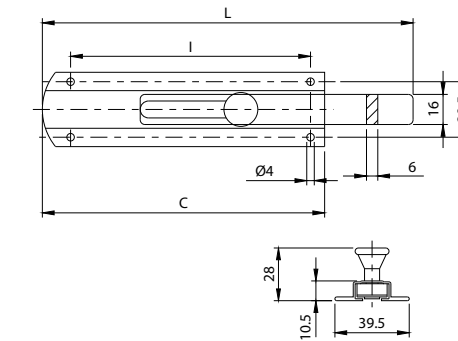

810

Catenaccio trasversale medio

☒ 16mm

Transverse medium bolt
Verrou transversal moyen
Horizontalstossriegel medium
Pasador transversal mediano 16 mm
Средняя поперечная цепь 16 мм



CODE	ART.	B	C	I	L	M	Box info	
							Pcs per pack	Kg
11909005 005	810-150	25,5	125,5	103	160	-	10	2,00
11909010 005	810-200	39,5	160	137	200	17	10	2,60
11909015 005	810-250	60	188	166	250	37	10	3,10
11909020 005	810-300	80,5	220	198	300	58	10	3,60
11909025 005	810-400	120	280	258	400	98	10	4,60

Finishing: Bronzato / Bronze plated

Categoria commerciale: 1D

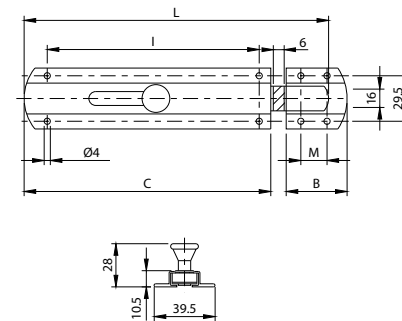

827

Incontro per catenaccio art. 825

Strike for bolt art. 825
Gâche pour verrou art. 825
Schliesskloben für Stossriegel Artikel 825
Encuentro para pasador art. 825
Упор для цепи арт. 825



CODE	ART.	Pcs per pack	Box info	
			Pcs per pack	Kg
12002005 005	827	50	1,30	

Finishing: Bronzato / Bronze plated

Categoria commerciale: 1D

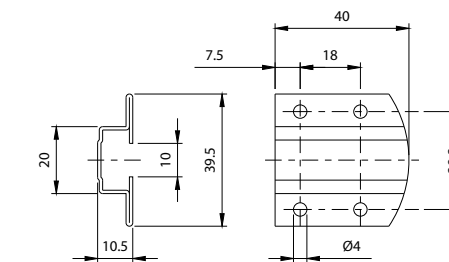

820

Catenaccio trasversale pesante

☒ 25mm

Transverse heavy bolt 25 mm
Verrou transversal lourd 25 mm
Horizontalstossriegel gross 25 mm
Pasador transversal pesado 25 mm
Тяжелая поперечная цепь 25 мм



CODE	ART.	B	C	I	L	M	Box info	
							Pcs per pack	Kg
11909505 005	820-200	40	160	127	200	-	4	2,40
11909510 005	820-300	71	230	197	300	40	4	3,40
11909515 005	820-400	100	300	267	400	70	4	4,50
11909520 005	820-500	100	400	384	500	70	4	5,90

Finishing: Bronzato / Bronze plated

Categoria commerciale: 1D

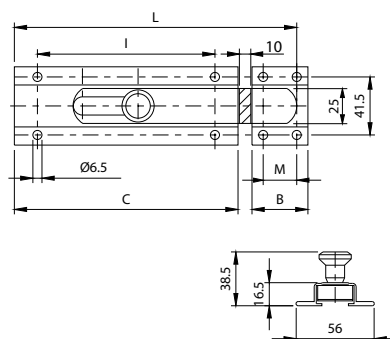



835

Catenaccio verticale pesante

☑ 25mm

Heavy vertical bolt

Verrou vertical lourd

Vertikaler Stossriegel gross

Pasador vertical pesado 25 mm

Тяжелая вертикальная цепь 25 мм



CODE	ART.	C	I	L	Box info	
					Pcs per pack	Kg
11910505 005	835-200	200	188	255	4	2,70
11910510 005	835-300	300	268	355	4	4,00
11910515 005	835-400	400	184	455	4	5,30
11910520 005	835-500	500	234	555	4	6,60
11910525 005	835-600	600	284	655	4	7,90
11910530 005	835-800	800	384	855	4	10,50

Finishing: Bronzato / Bronze plated

Categoria commerciale: 1D

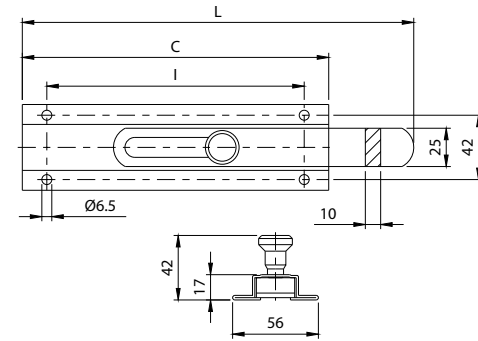

840

Catenaccio ad awitare zancato

Bolt to be screwed

Verrou à visser

Gekröpfter Stossriegel zum Anschrauben

Pasador para atomillar curvado

Навинчивающаяся цепь гнутая



CODE	ART.	C	I	L	Box info	
					Pcs per pack	Kg
11911005 001	840-200	200	177	228	10	2,90
11911010 001	840-300	300	277	328	10	4,40
11911015 001	840-400	400	188	428	10	5,80
11911020 001	840-500	500	240	528	10	7,10
11911025 001	840-600	600	290	628	10	8,50
11911035 001	840-800	800	260	828	10	11,50
11911045 001	840-1000	1000	330	1028	10	14,10

Finishing: Zincato / Galvanized

Categoria commerciale: 1D

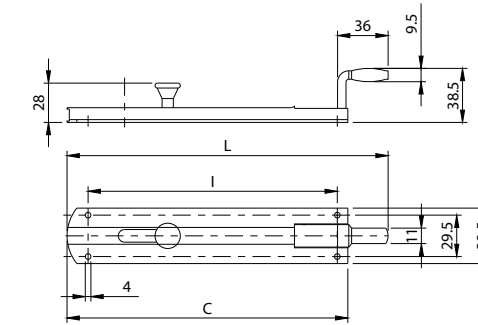

837

Incontro per catenaccio art. 835

Strike for bolt art. 835

Gâche pour verrou art. 835

Schliesskloben für Stossriegel Artikel 835

Encuentro para pasador art. 835

Упор для цепи арт. 835



CODE	ART.	Box info	
		Pcs per pack	Kg
12002505 005	837	50	3,8

Finishing: Bronzato / Bronze plated

Categoria commerciale: 1D

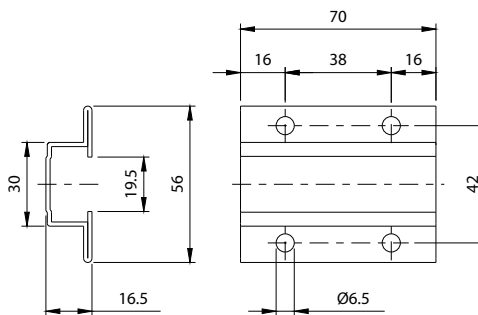

840D

Catenaccio ad awitare

Bolt to be screwed

Verrou à visser

Stossriegel zum Anschrauben

Pasador para atomillar

Навинчивающаяся цепь



CODE	ART.	C	I	L	Box info	
					Pcs per pack	Kg
11911505 001	840D-200	200	177	228	10	2,90
11911510 001	840D-300	300	277	328	10	4,40
11911515 001	840D-400	400	188	428	10	5,80
11911520 001	840D-500	500	240	528	10	7,10
11911525 001	840D-600	600	290	628	10	8,50
11911535 001	840D-800	800	260	828	10	11,50
11911545 001	840D-1000	1000	330	1028	10	14,10

Finishing: Zincato / Galvanized

Categoria commerciale: 1D

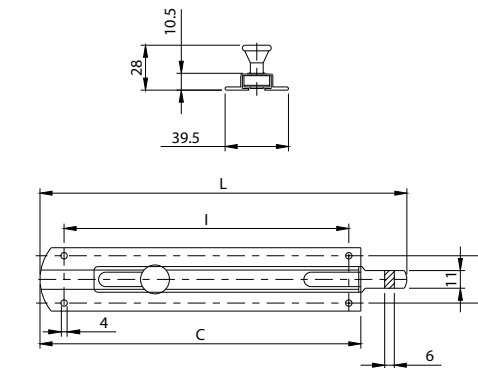



852

Incontro per catenaccio art. 800
Strike for bolt art. 800
Gâche pour verrou art. 800
Schliesskloben für Stossriegel Artikel 800
Encuentro para pasador art. 800
Упор для цепи арт. 800



CODE	ART.	Box info	
		Pcs per pack	Kg
12003005 001	852	50	1,00

Finishing: Zincato / Galvanized

Categoria commerciale: 1D

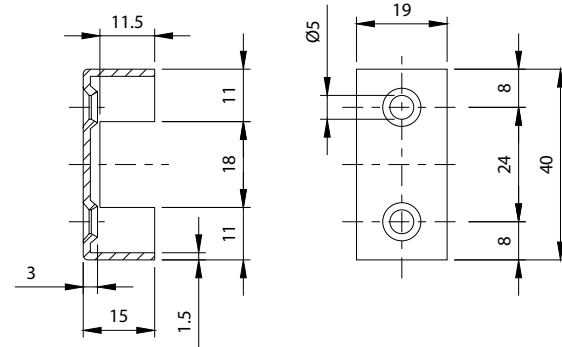

857

Incontro per catenaccio art. 740
Strike for bolt art. 740
Gâche pour verrou art. 740
Schliesskloben für Stossriegel Artikel 740
Encuentro para pasador art. 740
Упор для цепи арт. 740



CODE	ART.	Box info	
		Pcs per pack	Kg
12004005 001	857	50	2,90

Finishing: Zincato / Galvanized

Categoria commerciale: 1D

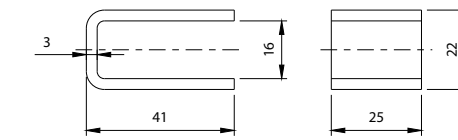

855

Incontro per catenaccio art. 735
Strike for bolt art. 735
Gâche pour verrou art. 735
Schliesskloben für Stossriegel Artikel 735
Encuentro para pasador art. 735
Упор для цепи арт. 735



CODE	ART.	Box info	
		Pcs per pack	Kg
12003505 001	855	50	1,50

Finishing: Zincato / Galvanized

Categoria commerciale: 1D

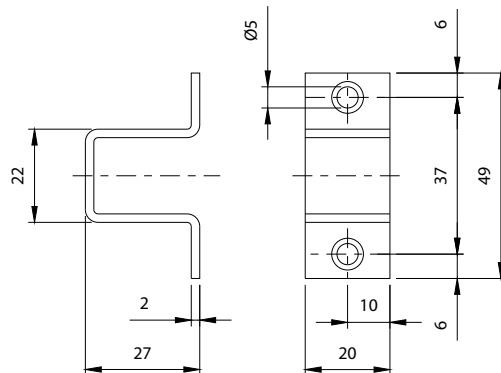

860

Catenaccio pesante asta tonda
Ø16mm
Heavy bolt with round rod
Verrou lourd tringle ronde
Stossriegel mit abgerundeter Stange gross
Pasador pesado varilla redonda Ø 16 mm
Тяжелая цепь круглый стержень Ø 16 мм



CODE	ART.	L	Box info	
			Pcs per pack	Kg
11913001 001	860-240	240	4	3,90

Finishing: Zincato / Galvanized

Categoria commerciale: 1D

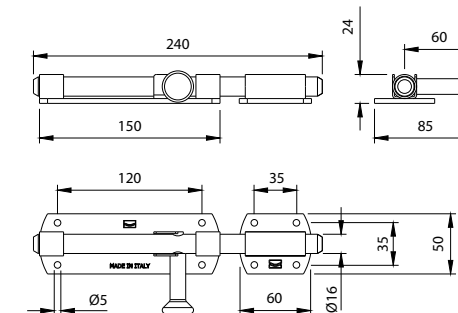



Incontri per serrature

Latch strike plates

275

Battente porta incontro a montaggio rapido regolabile

Easy to set up adjustable batten
Battant réglable à montage rapide
Einfach zum Einstellen verstellbares Schließblech
Batiente de la puerta con encuentro de montaje rápido regulable
Дверной стопор с быстрым монтажом регулируемый



CODE	ART.	R	Box info	
			Pcs per pack	Kg
10702005 001	275	40-50	4	2,8

Finishing: Zincato / Galvanized

Categoria commerciale: 1G

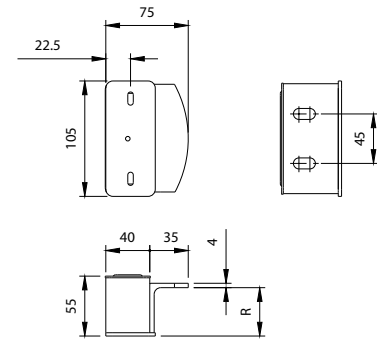

275PST

Battente porta incontro regolabile a fissare

Adjustable batten to be screwed
Battant réglable à visser
Verstellbares Schließblech zum Anschrauben
Batiente de la puerta con encuentro regulable para fijar
Прикрепляемый дверной стопор регулируемый



CODE	ART.	R	Box info	
			Pcs per pack	Kg
10701301 001	275PST	40-50	4	3,9

Finishing: Zincato / Galvanized

Categoria commerciale: 1G

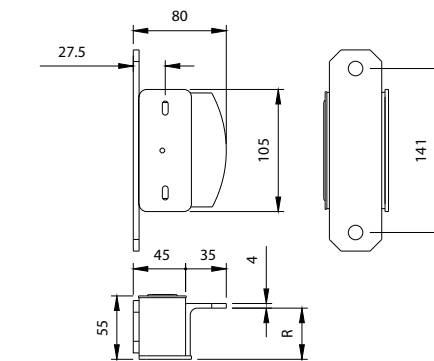

275F

Battente porta incontro

Battent
Battant
Schließblech
Batiente de la puerta con encuentro
Дверной стопор



CODE	ART.	H	Box info	
			Pcs per pack	Kg
10702010 001	275F-30	37	4	2,2
10702015 001	275F-40	47	4	2,4
10702020 001	275F-50	57	4	2,8
10702025 001	275F-60	67	4	2,9

Finishing: Zincato / Galvanized

Categoria commerciale: 1G

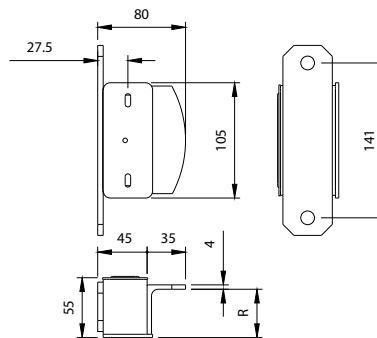

276

Battente porta incontro regolabile a fissare con ammortizzatori

Adjustable batten to be screwed with shock absorber cups
Battant réglable à visser avec bouchons amortisseurs
Verstellbares Schließblech zum Anschrauben mit Schlusdämpfern
Batiente de la puerta con encuentro regulable para fijar con amortiguadores
Прикрепляемый дверной стопор регулируемый с амортизаторами



CODE	ART.	R	Box info	
			Pcs per pack	Kg
10701401 001	276	50-70	4	7,3

Finishing: Zincato / Galvanized

Categoria commerciale: 1G

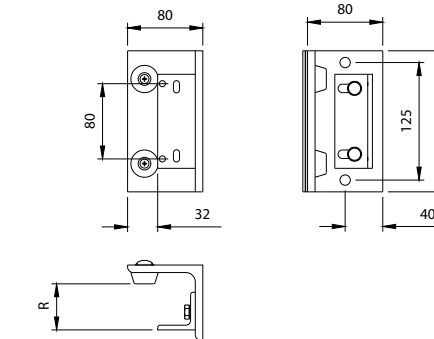

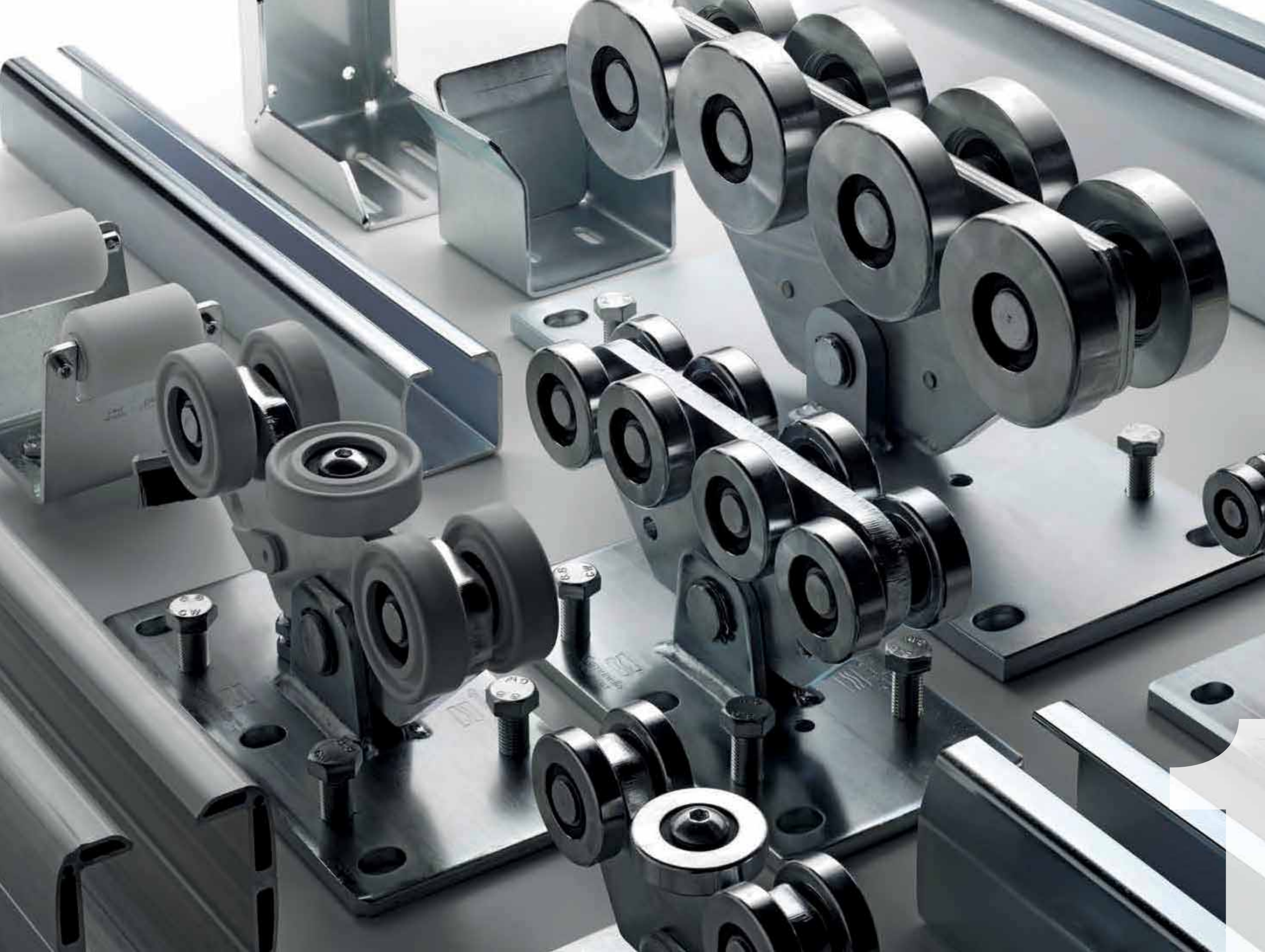

CANCELLI AUTOPORTANTI

CANTILEVER GATE SYSTEMS

10

REGULAR
FORCE
CANTILEVER SYSTEM

HIGH
FORCE
CANTILEVER SYSTEM

MAX
FORCE
CANTILEVER SYSTEM

GRANDE



CGS 250.5 G



CGS 250.8 G



CGS 350.5 G



CGS 350.8 G

PICCOLO



CGS 150.5 P

CGA 150.5 P



CGS 250.5 P



CGS 250.8 P

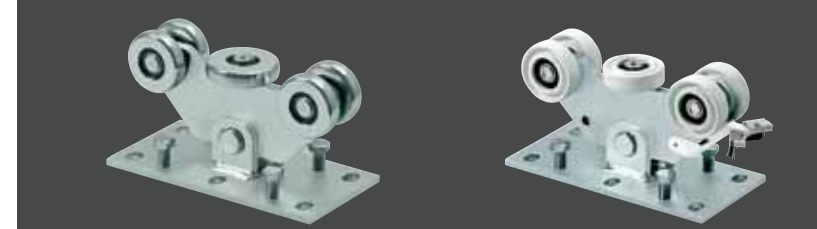

CGS 350.5 P
CGI 350.5 P INOX

CGA 350.5 P

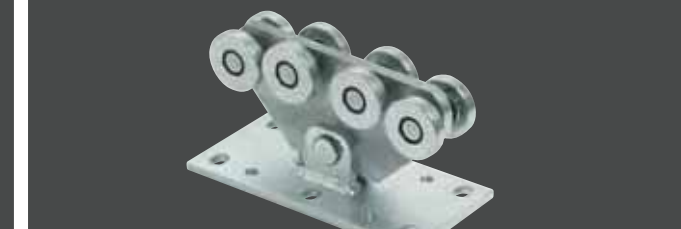

CGS 350.8 P

MINI

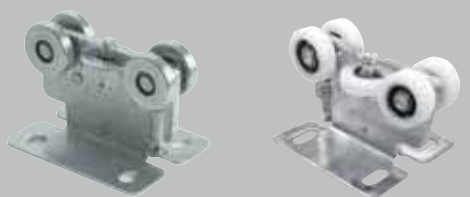

CGS 150.5 M

CGA 150.5 M



CGS 250.5 M



CGS 250.8 M

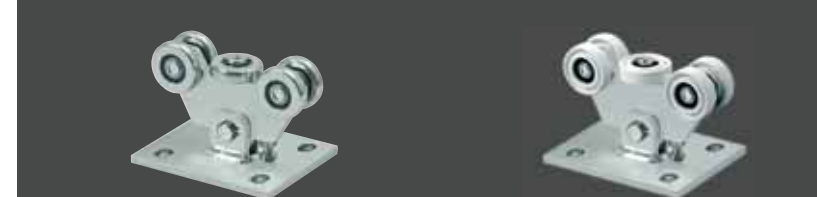

CGS 350.5 M

CGA 350.5 M



CGS 350.8 M

3 livelli di resistenza.

Una riduzione della distanza tra i carrelli causa un aumento del carico a cui i carrelli stessi devono resistere.

3 levels of resistance.

Decreasing in the distance between the two carriages increases the load that the carriages have to bear.



Per una completa configurazione del tuo cancello vai al sito www.comunello.com > gate > configuratori

For the complete gate configurator go to www.comunello.com > gate > configurators



Residential gates

Configuratore cancello autoportante.
Scegli dalla nostra gamma di componenti
di alta qualità.

Cantilever gate configurator.
Choose from our vast range of
high quality components.



Terminale per monorotaia
End stopper for monorail



ART.	PAG.
CG-20 M	266
CGA-20 M	267
CGA-347 M	263
CGS-347 M	262
CGi-347 M	262

Carrelli / Carriages



ART.	PAG.
CGS 150.5 P	218
CGA 150.5 P	222
CGS 150.5 M	216
CGA 150.5 M	220

Binari / Tracks

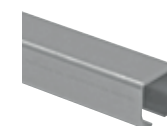

ART.	PAG.
CGS-245M	258
CGS-245P	258

Piastre / Guide plates



ART.	PAG.
247	87
250	88
250i	88
251	89
252	90
253	90
255	91
255i	91
256	92
257	91
258	93
CG-251	271
CGi-251	271
CG-252	272

Incontro / End cup



ART.	PAG.
CG-25 M	268
CG-30 M	269

Incontro inferiore / Bottom end cup



ART.	PAG.
203	81
CGS-346	261
CGi-346	261

Cremagliere / Racks



ART.	PAG.
260	273
260i	273
261	96
262	274
262i	274

Residential / Industrial gates

Configuratore cancello autoportante.
Scegli dalla nostra gamma di componenti
di alta qualità.

Cantilever gate configurator.
Choose from our vast range of
high quality components.



Piastre / Guide plates

ART.	PAG.
247	87
250	88
250i	88
251	89
252	90
253	90
255	91
255i	91
256	92
257	91
258	93
CG-251	271
CGi-251	271
CG-252	272

Incontro / End cup

ART.	PAG.
CG-25 P	268
CG-30 P	269
CG-25 M	268
CG-30 M	269

Incontro inferiore / Bottom end cup

ART.	PAG.
203	81
CGS-346 M	261
CGS-346 P	261
CGi-346	261

Terminale per monorotaia
End stopper for monorail

ART.	PAG.
CG-20 P	266
CGA-20 P	267
CGA-347 P	263
CGS-347 P	262
CGi-347 P	262

Carrelli / Carriages

ART.	PAG.
CGS-250.5 M	224
CGS-250.5 P	226
CGS-250.5 G	228
CGS-250.8 M	230
CGS-250.8 P	232
CGS-250.8 G	234
CGA-350.5 P	244

Binari / Tracks

ART.	PAG.
CGS-245M	258
CGS-245P	258
CGS-245G	258
CGA-345 P	260

Cremagliere / Racks

ART.	PAG.
260	273
260i	273
261	96
262	274
262i	274



Industrial gates

Configuratore cancello autoportante.
Scegli dalla nostra gamma di componenti
di alta qualità.

Cantilever gate configurator.
Choose from our vast range of
high quality components.



Terminale per monorotaia
End stopper for monorail

ART.	PAG.
CG-20 G	266
CGA-20 G	267
CGA-347 G	263
CGS-347 G	262
CGi-347 G	262

Carrelli / Carriages

ART.	PAG.
CGS 350.5 M	263
CGA 350.5 M	242
CGS 350.5 P	238
CGA 350.5 P	244
CGi 350.5 P INOX	252
CGS 350.5 G	240
CGS 350.8 M	246
CGS 350.8 P	248
CGS 350.8 G	250

Binari / Tracks

ART.	PAG.
CGS-245M	258
CGS-245P	258
CGS-245G	258
CGA-345 P	260

Piastre / Guide plates

ART.	PAG.
247	87
250	88
250i	88
251	89
252	90
253	90
255	91
255i	91
256	92
257	91
258	93
CG-251	271
CGi-251	271
CG-252	272

Incontro / End cup

ART.	PAG.
CG-25 G	268
CG-30 G	269
CG-25 P	268
CG-30 P	269

Incontro inferiore / Bottom end cup

ART.	PAG.
203	81
CGS-346 G	261
CGS-346 P	261

Cremagliere / Racks

ART.	PAG.
260	273
260i	273
261	96
262	274
262i	274

KIT 150-300K

Kit per cancelli autoportanti fino a 3m e 300Kg di peso
Kit for cantilever gates, weight up to 3 m and 300 kg / Kit pour portails autoportants jusqu'à 3m et 300 kilos de poids / Kit für selbsttragende Tore mit Gewicht bis 3m und 300 kg / Kit para puertas autoportantes de hasta 3 m y 300 kg de peso / Комплект для самонесущих ворот до 3 м и 300 кг веса

CODE	ART.	CGS-150.5M	CGS-347M	CGS-346M	230	255	CGS-245M
19912331	KIT 150-300K TOP 6M	2 Mini	1	1	-	1 (220 / Ø30)	1 (6 m)
19912330	KIT 150-300K TOP 3M	2 Mini	1	1	-	1 (220 / Ø30)	2 (3 m)
19912333	KIT 150-300K BASIC 6M	2 Mini	1	1	4 x Ø30	-	1 (6 m)
19912326	KIT 150-300K BASIC 3M	2 Mini	1	1	4 x Ø30	-	2 (3 m)



PATENTED

Categoria commerciale: 1U

Dimensioni minime getto cemento armato
Minimum dimensions of the reinforced concrete casting
Dimensions minimums du coulage du ciment armé
Mindestgröße des Stahlbetonguss
Dimensiones mínimas colada cemento armado
Минимальные размеры железобетонной стяжки

CGS 150.5 Mini Capacity = 700 kg						
P	L=2 m		L=2,5 m		L=3 m	
Weight (Kg)	FA (M)	I (M)	FA (M)	I (M)	FA (M)	I (M)
100	0,90	0,30	1,00	0,40	1,00	0,40
125	1,00	0,40	1,00	0,40	1,10	0,50
150	1,00	0,40	1,10	0,50	1,20	0,60
200	1,20	0,60	1,30	0,70	1,40	0,80
250	1,40	0,80	1,50	0,90	1,70	1,10
300	1,60	1,40	1,80	1,30	2,10	1,50

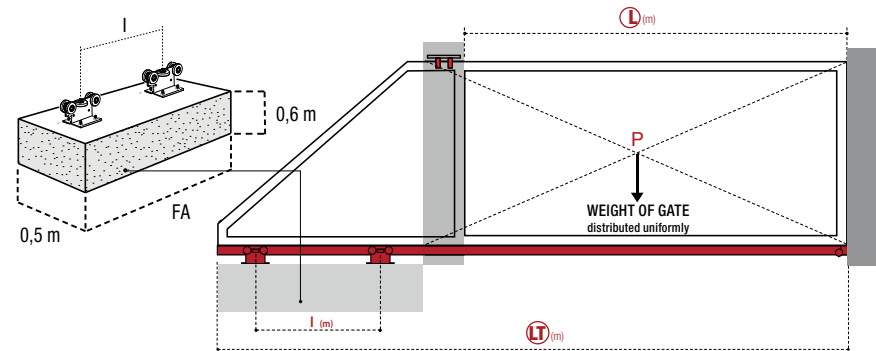

Si consiglia comunque un interasse (I) minimo di 1/3 della lunghezza (L)
Nevertheless, it is advisable a minimum wheelbase (I) of about 1/3 of the length (L)
Cependant, il est conseillé un entraxe minimal (I) de 1/3 de la longueur (L)
Die empfohlene Strecke (I) 1/3 ist mindestens ein Drittel der Länge (L)
Se recomienda una distancia mínimo entre ejes (I) de 1/3 de la longitud (L)
Минимальные размеры железобетонной стяжки

CGS-150.5M

Carrello auto-portante 5 ruote per cancelli a sbalzo
5 wheels cantilever carriage for gates
Chariot autoportant 5 roues pour portails
5-rädriger Laufwagen für freitragende Tore
Carro autoportante 5 ruedas para puertas correderas
Самонесущая тележка 5 колес для откидных ворот

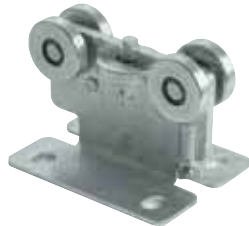

CODE	ART.	Size	Box info	
			Pcs per pack	Kg
10130019 001	CGS-150.5 M	Mini	1	5,4

Finishing: Zincato / Galvanized

Categoria commerciale: 1Q

CGS-347M

Ruota terminale per monorotaia
End wheel for monorail
Galet d'extrémité pour rail
Endrad für Einfachschiene
Rueda terminal para monorail
Концевое колесо монорельса



CODE	ART.	Size	A	B	C	D	E	F	G	H	L	M	N	S	Box info	
			Pcs per pack	Kg												
10705001 001	CGS-347M	Mini	135	68	82,5	Ø 68	123	12	14,5	68	45	32	15	4	2	2,00

Finishing: Zincato / Galvanized

Categoria commerciale: 1T

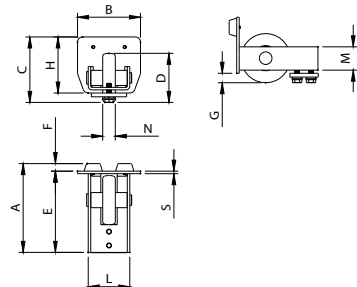

CGS-346M

Incontro inferiore a fissare
Bottom end cup to be fixed
Butée inférieure à fixer
Unteraufgesschuh zum Aufschrauben
Encuentro inferior para fijar
Прикрепляемый нижний упор



CODE	ART.	Size	A	B	C	D	E	F	G	H	I	S	Box info	
			Pcs per pack	Kg										
10705501 001	CGS-346M	Mini	104	78	25	9	75	114	25	91	38	4	2	2,30

Finishing: Zincato / Galvanized

Categoria commerciale: 1T

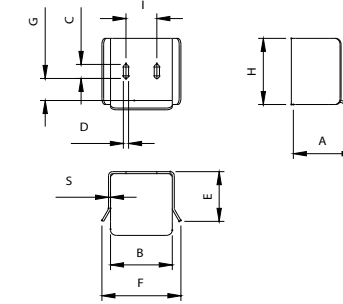

230

Oliva in nylon
Nylon roller
Rouleau en nylon
Nylon-Führungsrolle
Encuentro inferior para fijar
Прикрепляемый нижний упор



CODE	ART.	A	B	D	I	H	Box info	
		Pcs per pack	Kg					
11301010 001	230-30	40	Ø30	74	M16	24	20	3,70

Finishing: Zincato / Galvanized

Categoria commerciale: 1L

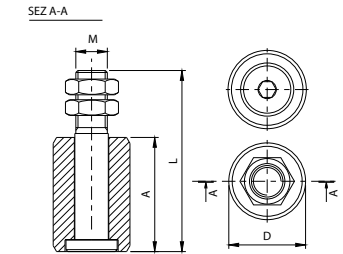

255

Piastra guida cancello a doppia regolazione
Guiding plate for gates with double adjustment
Platine guide-portail à double réglage
Torführungsbügel mit Doppelverstellung
Placa de guía de la puerta de doble regulación
Пластина направляющая ворот с двойным регулированием

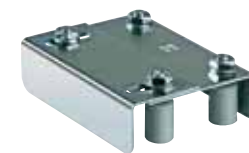

CODE	ART.	Size	C	D	E	H	L	M	R	S	Box info	
			Pcs per pack	Kg								
11306005 001	255-220	Ø30	40	Ø30	135-175	74	220	38	35-62	3	10	22,70

Finishing: Zincato / Galvanized

Categoria commerciale: 1L

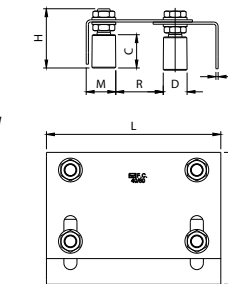

CGS-245M

Monorotaia per cancelli auto-portanti
Monorail for cantilever gates
Rails pour portails autoportants
Einfachschiene für selbsttragende Tore
Monorail para puertas autoportantes
Монорельс для самонесущих ворот

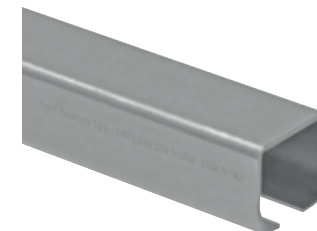

CODE	ART.	Size	A	B	C	H	S	L	Box info	
			Pcs per pack	Kg						
10207004 001	CGS-245M	Mini	48	68	23	68	3,5	3000	1	18,3
10207024 001	CGS-245M	Mini	48	68	23	68	3,5	6000	1	36,5

Finishing: Zincato / Galvanized

Categoria commerciale: 1R

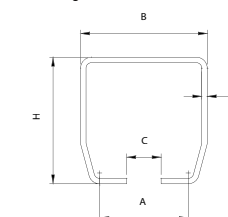

KIT 150-600K

Kit per cancelli autoportanti fino a 6m e 600Kg di peso
Kit for cantilever gates, weight up to 6m and 600 kg / Kit pour portails autoportants jusqu'à 6m et 600 kilos de poids / Kit für selbsttragende Tore mit Gewicht bis 6m und 600 kg / Kit para puertas autoportantes de hasta 6 m y 600 kg de peso / Комплект для самонесущих ворот до 6 м и 600 кг веса

CODE	ART.	CGS-150.5P	CGS-347P	CGS-346P	230	255	CGS-245P
19912332	KIT 150-600K TOP 6M	2 Piccolo	1	1	-	1 (350 / Ø40)	2 (6 m)
19912325	KIT 150-600K TOP 3M	2 Piccolo	1	1	-	1 (350 / Ø40)	3 (3 m)
19912334	KIT 150-600K BASIC 6M	2 Piccolo	1	1	4 x Ø40	-	2 (6 m)
19912324	KIT 150-600K BASIC 3M	2 Piccolo	1	1	4 x Ø40	-	3 (3 m)



PATENTED

Categoria commerciale: 1U

Dimensioni minime getto cemento armato
Minimum dimensions of the reinforced concrete casting
Dimensions minimums du coulage du ciment armé
Mindestgröße des Stahlbetonguss
Dimensiones mínimas colada cemento armado
Минимальные размеры железобетонной стяжки

CGS 150.5 Piccolo Capacity = 1300 kg						
P	L=4 m		L=5 m		L=6 m	
Weight (Kg)	FA (M)	I (M)	FA (M)	I (M)	FA (M)	I (M)
350	1,8	1,1	2,1	1,4	2,4	1,7
400	2,0	1,3	2,3	1,6	2,7	2,0
450	2,2	1,5	2,6	1,9	3,1	2,4
500	2,5	1,8	3,0	2,3	3,5	2,8
550	2,8	2,1	3,3	2,6	3,9	3,2
600	3,2	2,5	3,8	3,1	4,5	3,8

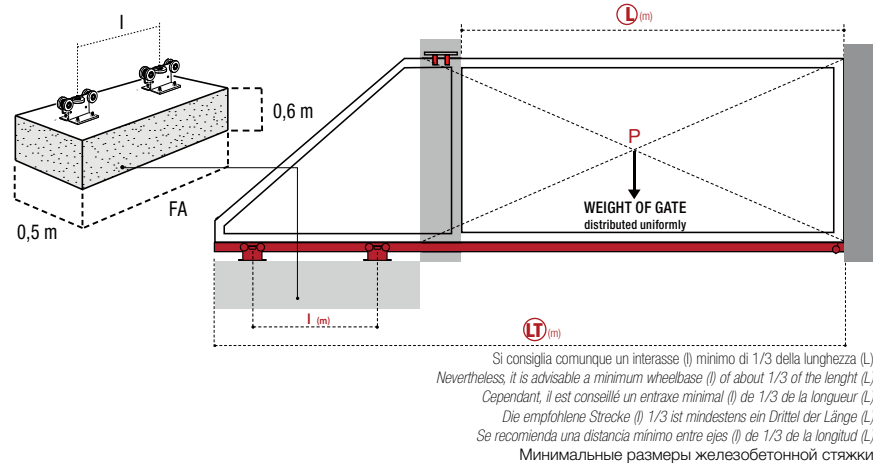

CGS-150.5P

Carrello auto-portante 5 ruote per cancelli a sbalzo
5 wheels cantilever carriage for gates
Chariot autoportant 5 roues pour portails
5-rädriger Laufwagen für freitragende Tore
Carro autoportante 5 ruedas para puertas correderas
Самонесущая тележка 5 колес для откидных ворот

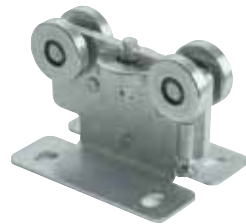

CODE	ART.	Size	Box info	
			Pcs per pack	Kg
10130020 001	CGS-150.5 P	Piccolo	1	5,4

Finishing: Zincato / Galvanized Categoria commerciale: 1Q

CGS-347P

Ruota terminale per monorotaia
End wheel for monorail
Gaiet d'extrémité pour rail
Endrad für Einfachschiene
Rueda terminal para monocarril
Концевое колесо монорельса



CODE	ART.	Size	A	B	C	D	E	F	G	H	L	M	N	S	Box info	
			Pcs per pack	Kg												
10705005 001	CGS-347P	Piccolo	141	100	104	Ø78	129	12	15	89	66	37	20	4	2	3,40

Finishing: Zincato / Galvanized Categoria commerciale: 1T

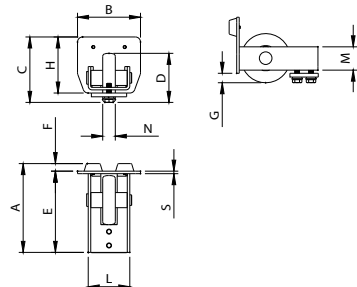

CGS-346P

Incontro inferiore a fissare
Bottom end cup to be fixed
Butée inférieure à fixer
Unteraufageschuh zum Aufschrauben
Encuentro inferior para fijar
Прикрепляемый нижний упор



CODE	ART.	Size	A	B	C	D	E	F	G	H	I	S	Box info	
			Pcs per pack	Kg										
10705505 001	CGS-346P	Piccolo	119	112	30	11	84	154	33	112	50	4	2	3,60

Finishing: Zincato / Galvanized Categoria commerciale: 1T

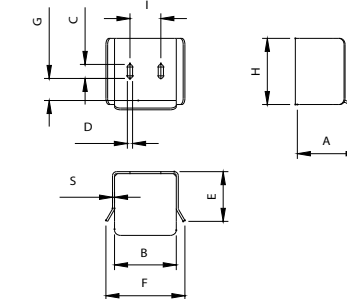

230

Oliva in nylon
Nylon roller
Rouleau en nylon
Nylon-Führungsrolle
Encuentro inferior para fijar
Прикрепляемый нижний упор



CODE	ART.	A	B	D	I	H	Box info	
		Pcs per pack	Kg					
11301015 001	230-40	58	Ø39	98	M16	24	20	5,30

Finishing: Zincato / Galvanized Categoria commerciale: 1L

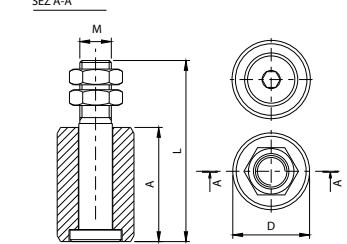

255

Piastra guida cancello a doppia regolazione
Guiding plate for gates with double adjustment
Platine guide-portail à double réglage
Torführungsbügel mit Doppelverstellung
Placa de guía de la puerta de doble regulación
Пластина направляющая ворот с двойным регулированием



CODE	ART.	Size	C	D	E	H	L	M	R	S	Box info	
			Pcs per pack	Kg								
11306010 001	255-350	Ø40	58	Ø39	176-222	98	350	47	62-85	4	5	27,90

Finishing: Zincato / Galvanized Categoria commerciale: 1L

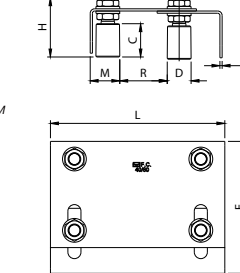

CGS-245P

Monorotaia per cancelli auto-portanti
Monorail for cantilever gates
Rails pour portails autoportants
Einfachschiene für selbsttragende Tore
Monocarril para puertas autoportantes
Монорельс для самонесущих ворот

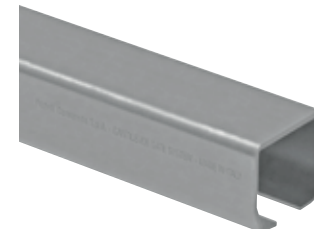

CODE	ART.	Size	A	B	C	H	S	L	Box info	
			Pcs per pack	Kg						
10207006 001	CGS-245P	Piccolo	66,5	100	33	89	5	3000	1	35,0
10207025 001	CGS-245P	Piccolo	66,5	100	33	89	5	6000	1	70,0

Finishing: Zincato / Galvanized Categoria commerciale: 1R

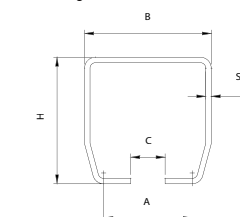



KIT CGA 150-300K

Kit per cancelli autoportanti in alluminio
Kit for cantilever gates, in aluminium
Kit pour portails autoportants aluminium
Kit Aluminium freitragende Tore
Kit para puertas autoportantes de aluminio
Комплект для самонесущих ворот из алюминия

CODE	ART.	CGA-150.5M	CGA-347M	CGS-346M	CGA-20M
19912494	KIT 150-300K ALUMINIUM	2 Mini	1	1	1

Categoria commerciale: 1U



CGA-347M

Ruota terminale in nylon per monorotaia in alluminio
Nylon end wheel for aluminium monorail
Galet d'extrémité en nylon pour rail en aluminium
Nylon-Endrolle für Einfachschiene aus Aluminium
Rueda terminal de nylon para monorail de aluminio
Концевое колесо из нейлона для алюминиевого монорельса



CODE	ART.	Size	A	B	C	D	E	F	G	H	L	M	N	Box info	
														Pcs per pack	Kg
10705200	001 CGA-347M	Mini	119	83	83	∅66	119	16	7	79	45	32	15	1	1,6

Finishing: Alluminio / Aluminium

Categoria commerciale: 1T

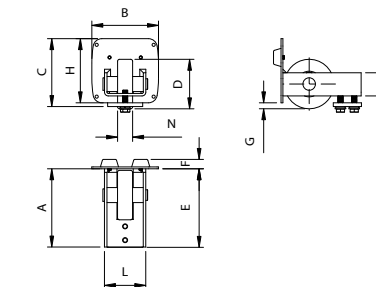

Dimensioni minime getto cemento armato
Minimum dimensions of the reinforced concrete casting
Dimensions minimums du coulage du ciment armé
Mindestgröße des Stahlbetonguss
Dimensiones mínimas colada cemento armado
Минимальные размеры железобетонной стяжки

CGA 150.5 Mini Capacity = 700 kg						
P	L=2 m		L=2,5 m		L=3 m	
Weight (Kg)	FA (M)	I (M)	FA (M)	I (M)	FA (M)	I (M)
100	0,90	0,30	1,00	0,40	1,00	0,40
125	1,00	0,40	1,00	0,40	1,10	0,50
150	1,00	0,40	1,10	0,50	1,20	0,60
200	1,20	0,60	1,30	0,70	1,40	0,80
250	1,40	0,80	1,50	0,90	1,70	1,10
300	1,60	1,40	1,80	1,30	2,10	1,50

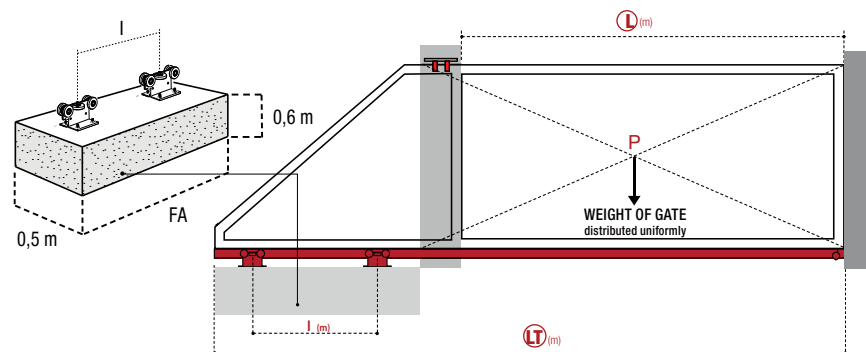

CGS-346M

Incontro inferiore a fissare
Bottom end cup to be fixed
Butée inférieure à fixer
Unterauflageschuh zum Aufschrauben
Encuentro inferior para fijar
Прикрепляемый нижний упор



CODE	ART.	Size	A	B	C	D	E	F	G	H	I	S	Box info	
													Pcs per pack	Kg
10705501	001 CGS-346M	Mini	104	78	25	9	75	114	25	91	38	4	1	1,8

Finishing: Zincato / Galvanized

Categoria commerciale: 1T

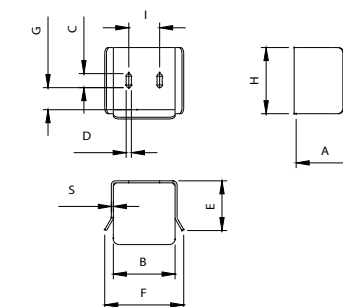

CGA-150.5M

Carrello auto-portante 5 ruote per cancelli a sbalzo
5 wheels cantilever carriage for gates
Chariot autoportant 5 roues pour portails
5-rädriger Laufwagen für freitragende Tore
Carro autoportante 5 ruedas para puertas correderas
Самонесущая тележка 5 колес для откидных ворот



CODE	ART.	Size	Box info	
			Pcs per pack	Kg
10130630	001 CGA-150.5 M	Mini	1	3,1

Categoria commerciale: 1Q

CGA-20M

Terminale per monorotaia in alluminio
End stopper for aluminium monorail
Embout d'extrémité pour rail en aluminium
Endtropfen für Einfachschiene aus Aluminium
Terminal para monorail de aluminio
Наконечник для алюминиевого монорельса



CODE	ART.	A	B	F	H	Box info	
						Pcs per pack	Kg
10707001	001 CGA-20M	16	83	12	79	1	0,3

Finishing: Alluminio / Aluminium

Categoria commerciale: 1T

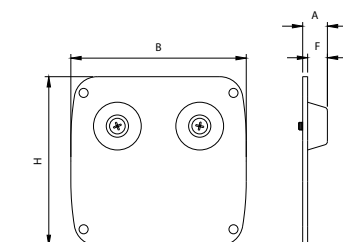



KIT CGA 150-600K

Kit per cancelli autoportanti fino a 600Kg di peso
Kit for cantilever gates, weight up to 600 kg
Kit pour portails autoportants jusqu'à 600 kilos de poids
Kit für selbsttragende Tore mit Gewicht bis 600 kg
Kit para puertas autoportantes de hasta 600 kg de peso
Комплект для самонесущих ворот до 600 кг веса

CODE	ART.	CGA-150.5P AL	CGA-347P	CGS-346P	CGA-20P
19912495	KIT 150-600K ALUMINIUM	2 Mini	1	1	1

Categoria commerciale: 1U



CGA-347P

Ruota terminale in nylon per monorotaia in alluminio
Nylon end wheel for aluminium monorail
Galet d'extrémité en nylon pour rail en aluminium
Nylon-Endrolle für Einfachschiene aus Aluminium
Rueda terminal de nylon para monorail de aluminio
Концевое колесо из нейлона для алюминиевого монорельса



CODE	ART.	Size	A	B	C	D	E	F	G	H	L	M	N	Box info	
														Pcs per pack	Kg
10705205 001	CGA-347P	Piccolo	140	106,5	118	Ø 79	125	15	9,6	102,5	66	37	26	2	3,4

Finishing: Zincato / Galvanized

Categoria commerciale: 1T

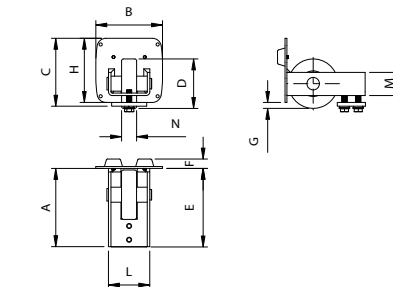

Dimensioni minime getto cemento armato
Minimum dimensions of the reinforced concrete casting
Dimensions minimums du coulage du ciment armé
Mindestgröße des Stahlbetonguss
Dimensiones mínimas colada cemento armado
Минимальные размеры железобетонной стяжки

CGA 150.5 Piccolo Capacity = 1300 kg						
P	L=4 m		L=5 m		L=6 m	
Weight (Kg)	FA (M)	I (M)	FA (M)	I (M)	FA (M)	I (M)
350	1,8	1,1	2,1	1,4	2,4	1,7
400	2,0	1,3	2,3	1,6	2,7	2,0
450	2,2	1,5	2,6	1,9	3,1	2,4
500	2,5	1,8	2,3	3,0	3,5	2,8
550	2,8	2,1	3,3	2,6	3,9	3,2
600	3,2	2,5	3,8	3,1	4,5	3,8

CGA-346P

Incontro inferiore a fissare
Bottom end cup to be fixed
Butée inférieure à fixer
Unteraufageschuh zum Aufschrauben
Encuentro inferior para fijar
Прикрепляемый нижний упор



CODE	ART.	Size	A	B	C	D	E	F	G	H	I	S	Box info	
													Pcs per pack	Kg
10705505 001	CGA-346P	Piccolo	119	112	30	11	84	154	33	112	50	4	2	3,60

Finishing: Zincato / Galvanized

Categoria commerciale: 1T

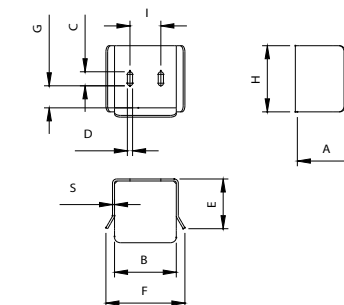

CGA-150.5P

Carrello auto-portante 5 ruote per cancelli a sbalzo
5 wheels cantilever carriage for gates
Chariot autoportant 5 roues pour portails
5-rädriger Laufwagen für freitragende Tore
Carro autoportante 5 ruedas para puertas correderas
Самонесущая тележка 5 колес для откидных ворот



CODE	ART.	Size	Box info	
			Pcs per pack	Kg
19912495	CGA-150.5 P	Mini	1	5,4

Categoria commerciale: 1Q

CGA-20P

Terminale per monorotaia in alluminio
End stopper for aluminium monorail
Embout d'extrémité pour rail en aluminium
Endtropfen für Einfachschiene aus Aluminium
Terminal para monorail de aluminio
Наконечник для алюминиевого монорельса



CODE	ART.	A	B	F	H	Box info	
						Pcs per pack	Kg
10707005 001	CGA-20P	15	106,5	12	102,5	2	0,60

Finishing: Zincato / Galvanized

Categoria commerciale: 1T

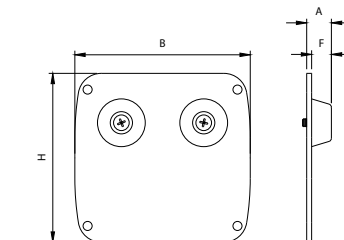



CGS-250.5 Mini

Carrello auto-portante 5 ruote per cancelli a sbalzo
5 wheels cantilever carriage for gates
 Chariot autoportant 5 roues pour portails
5-rädriger Laufwagen für freitragende Tore
 Carro autoportante 5 ruedas para puertas correderas
 Самонесущая тележка 5 колес для откидных ворот

CARATTERISTICHE

- Corpo multistrato brevettato
- Cuscinetti silenziosi di nuova generazione schermati per una migliore protezione dalla polvere; adatti a temperature che vanno dai -30° ai +80° C
- 4 ruote di supporto per ogni carrello
- Ruota centrale di allineamento
- Perno centrale di rotazione

FEATURES

- Patented multiplate body
- Noiseless bearings of new generation shielded to protect against dust suitable for temperatures from -30° C to +80° C
- 4 support wheels for each carriage
- Alignment Central wheel
- Central rotation pin

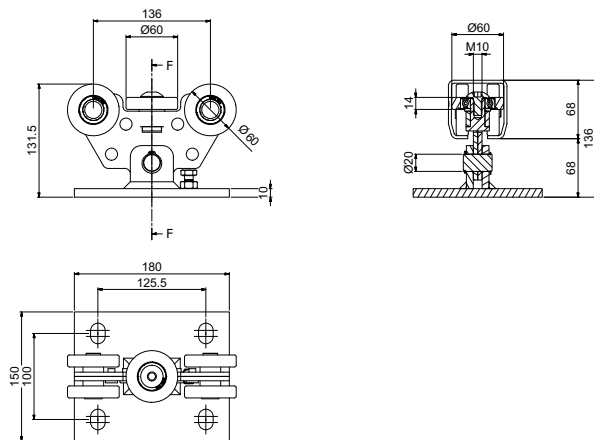

PATENTED

CODE	ART.	Size	Box info	
			Pcs per pack	Kg
10130030 001	CGS-250.5 M	Mini	1	5,4

Finishing: Zincato / Galvanized

Categoria commerciale: 10

Dimensioni minime getto cemento armato
 Minimum dimensions of the reinforced concrete casting
 Dimensions minimums du coulage du ciment armé
 Mindestgröße des Stahlbetonguss
 Dimensiones mínimas colada cemento armado
 Минимальные размеры железобетонной стяжки

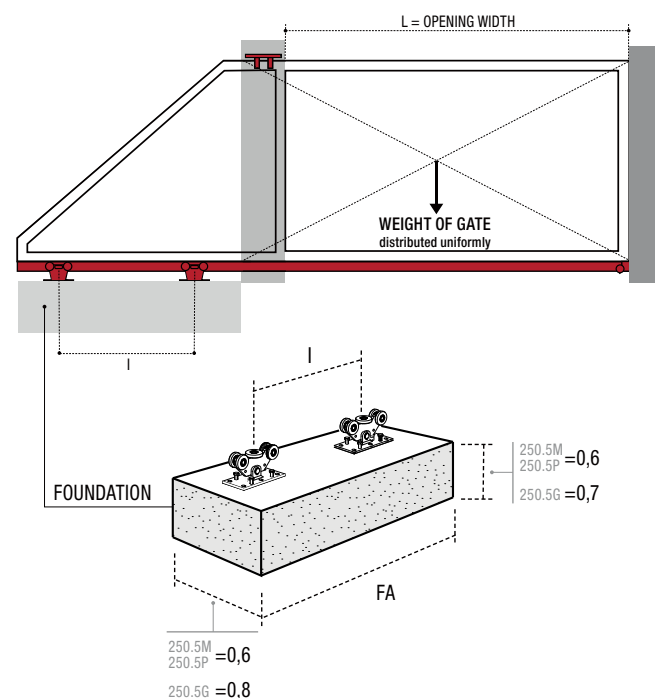

CGS 250.5 Mini (F1 max=450 Kg)								
Weight (Kg)	L=2 m		L=2,5 m		L=3 m		L=3,5 m	
	FA (M)	I (M)	FA (M)	I (M)	FA (M)	I (M)	FA (M)	I (M)
75	0,90	0,30	1,00	0,40	1,10	0,50	1,20	0,60
100	1,00	0,40	1,10	0,50	1,20	0,60	1,40	0,80
125	1,20	0,60	1,30	0,70	1,40	0,80	1,60	1,00
150	1,30	0,70	1,50	0,90	1,70	1,10	1,90	1,30

CGS-245M

Monorotaia per cancelli auto-portanti
Monorail for cantilever gates
 Rails pour portails autoportants
Einfachschiene für selbsttragende Tore
 Monocaril para puertas autoportantes
 Монорельс для самонесущих ворот

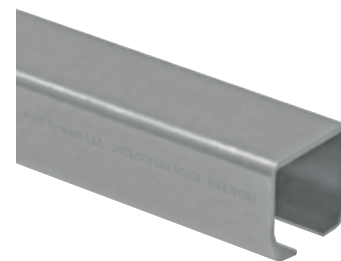

CODE	ART.	Size	Finishing	A	B	C	H	S	L	Box info	
										Pcs per pack	Kg
10207004	CGS-245M	Mini	Raw	48	68	23	68	3,5	3000	1	18,3
10207024	CGS-245M	Mini	Raw	48	68	23	68	3,5	6000	1	36,5
10207004 001	CGS-245M	Mini	Zinc	48	68	23	68	3,5	3000	1	18,3
10207024 001	CGS-245M	Mini	Zinc	48	68	23	68	3,5	6000	1	36,5

Categoria commerciale: 1R

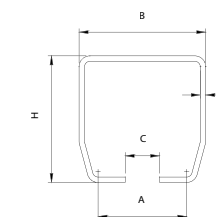

CGS-346M

Incontro inferiore a fissare
Bottom end cup to be fixed
 Butée inférieure à fixer
 Unteraufлагes Schuh zum Aufschrauben
 Encuentro inferior para fijar
 Прикрепляемый нижний упор



CODE	ART.	Size	A	B	C	D	E	F	G	H	I	S	Box info	
													Pcs per pack	Kg
10705501 001	CGS-346M	Mini	104	78	25	9	75	114	25	91	38	4	2	2,3

Finishing: Zincato / Galvanized

Categoria commerciale: 1T

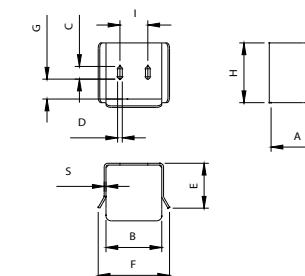

CGS-347M

Ruota terminale per monorotaia
End wheel for monorail
 Galet d'extrémité pour rail
 Endrad für Einfachschiene
 Rueda terminal para monocaril
 Концевое колесо монорельса



CODE	ART.	Size	A	B	C	D	E	F	G	H	L	M	N	S	Box info	
															Pcs per pack	Kg
10705001 001	CGS-347M	Mini	135	68	82,5	Ø68	123	12	14,5	68	45	32	15	4	2	2,0

Finishing: Zincato / Galvanized

Categoria commerciale: 1T

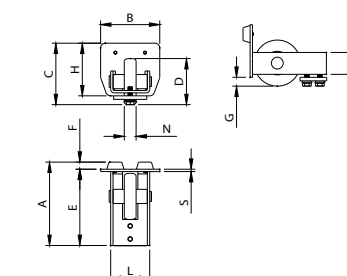



CGS-250.5 Piccolo

Carrello auto-portante 5 ruote per cancelli a sbalzo
5 wheels cantilever carriage for gates
Chariot autoportant 5 roues pour portails
5-rädiger Laufwagen für freitragende Tore
Carro autoportante 5 ruedas para puertas correderas
Самонесущая тележка 5 колес для откидных ворот

CARATTERISTICHE

- Corpo multistrato brevettato
- Cuscinetti silenziosi di nuova generazione schermati per una migliore protezione dalla polvere; adatti a temperature che vanno dai -30° ai +80°
- 4 ruote di supporto per ogni carrello
- Ruota centrale di allineamento
- Perno centrale di rotazione

FEATURES

- Patented multiplate body
- Noiseless bearings of new generation shielded to protect against dust suitable for temperatures from -30° C to +80° C
- 4 support wheels for each carriage
- Alignment Central wheel
- Central rotation pin

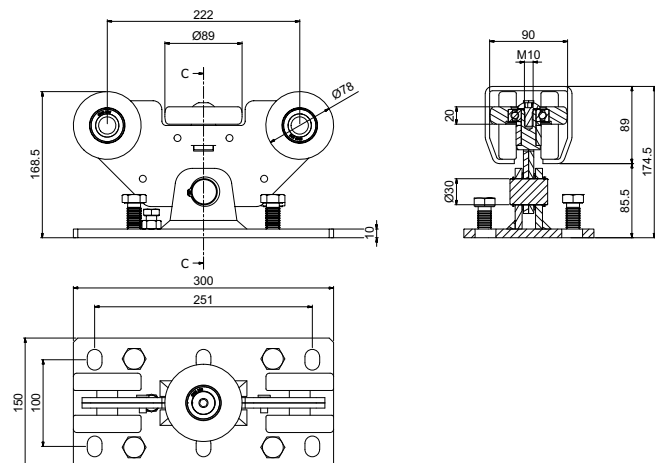

PATENTED

CODE	ART.	Size	Box info	
			Pcs per pack	Kg
10130031 001	CGS-250.5 P	Piccolo	1	10,6

Finishing: Zincato / Galvanized

Categoria commerciale: 10

Dimensioni minime getto cemento armato
Minimum dimensions of the reinforced concrete casting
Dimensions minimums du coulage du ciment armé
Mindestgröße des Stahlbetonguss
Dimensiones mínimas colada cemento armado
Минимальные размеры железобетонной стяжки

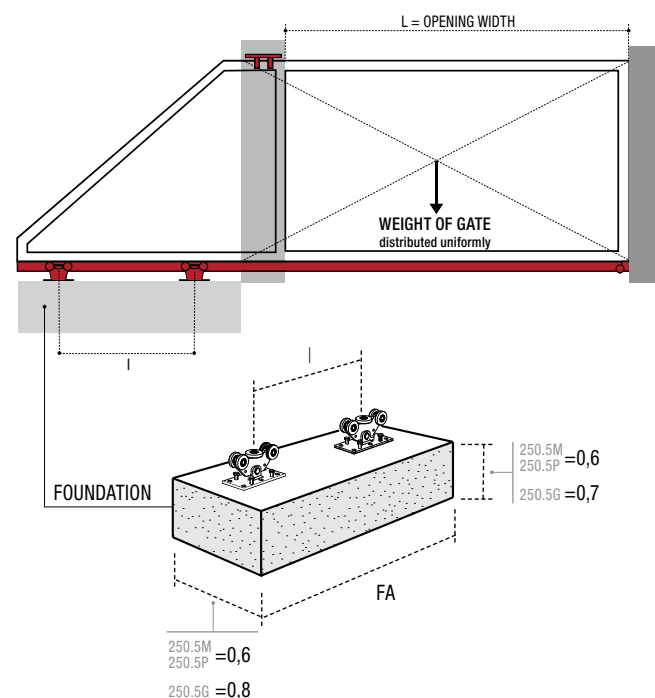

CGS 250.5 Piccolo (F1 max=750 Kg)										
Weight (Kg)	L=2,5 m		L=3 m		L=3,5 m		L=4 m		L=4,5 m	
	FA (M)	I (M)	FA (M)	I (M)	FA (M)	I (M)	FA (M)	I (M)	FA (M)	I (M)
150	1,20	0,50	1,30	0,60	1,40	0,70	1,60	0,90	1,70	1,00
175	1,30	0,60	1,40	0,70	1,60	0,90	1,70	1,00	1,90	1,20
200	1,40	0,70	1,60	0,90	1,70	1,00	1,90	1,20	2,10	1,40
225	1,50	0,80	1,70	1,00	1,90	1,20	2,10	1,40	2,30	1,60
250	1,70	1,00	1,90	1,20	2,10	1,40	2,30	1,60	2,50	1,80

CGS-245P

Monorotaia per cancelli auto-portanti
Monorail for cantilever gates
Rais pour portails autoportants
Einfachschiene für selbsttragende Tore
Monocaril para puertas autoportantes
Монорельс для самонесущих ворот

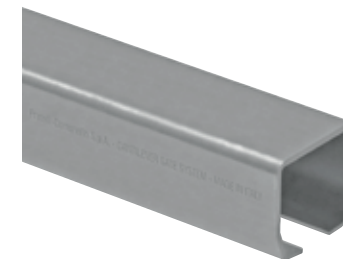

CODE	ART.	Size	Finishing	A	B	C	H	S	L	Box info	
										Pcs per pack	Kg
10207006	CGS-245P	Piccolo	Raw	66,5	100	33	89	5	3000	1	35,0
10207025	CGS-245P	Piccolo	Raw	66,5	100	33	89	5	6000	1	70,0
10207006 001	CGS-245P	Piccolo	Zinc	66,5	100	33	89	5	3000	1	35,0
10207025 001	CGS-245P	Piccolo	Zinc	66,5	100	33	89	5	6000	1	70,0

Categoria commerciale: 1R

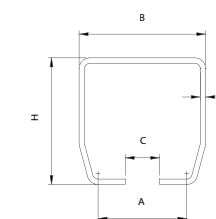

CGS-346P

Incontro inferiore a fissare
Bottom end cup to be fixed
Butée inférieure à fixer
Unterauflegesoh zum Aufschrauben
Encuentro inferior para fijar
Прикрепляемый нижний упор



CODE	ART.	Size	A	B	C	D	E	F	G	H	I	S	Box info	
													Pcs per pack	Kg
10705505 001	CGS-346P	Piccolo	119	112	30	11	84	154	33	112	50	4	2	3,6

Finishing: Zincato / Galvanized

10706005	CGI-346P	Piccolo	119	112	30	11	84	154	33	112	50	4	2	3,6
----------	----------	---------	-----	-----	----	----	----	-----	----	-----	----	---	---	-----

Finishing: Inox / Stainless steel

Categoria commerciale: 1T

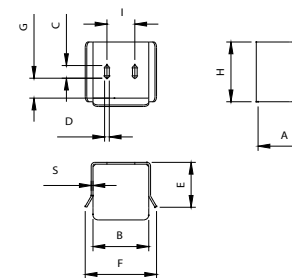

CGS-347P

Ruota terminale per monorotaia
End wheel for monorail
Galet d'extrémité pour rail
Endrad für Einfachschiene
Rueda terminal para monocaril
Концевое колесо монорельса



CODE	ART.	Size	A	B	C	D	E	F	G	H	L	M	N	S	Box info	
															Pcs per pack	Kg
10705005 001	CGS-347P	Piccolo	141	100	104	Ø78	129	12	15	89	66	37	20	4	2	3,4

Finishing: Zincato / Galvanized

10705305	CGI-347P	Piccolo	141	100	104	Ø78	129	12	15	89	66	37	20	4	2	3,4
----------	----------	---------	-----	-----	-----	-----	-----	----	----	----	----	----	----	---	---	-----

Finishing: Inox / Stainless steel

Categoria commerciale: 1T

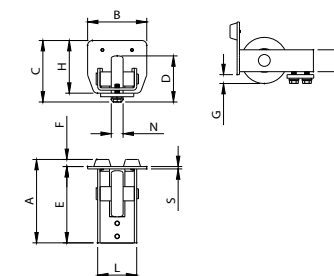



CGS-250.5 Grande

Carrello auto-portante 5 ruote per cancelli a sbalzo
5 wheels cantilever carriage for gates
Chariot autoportant 5 roues pour portails
5-rädriger Laufwagen für freitragende Tore
Carro autoportante 5 ruedas para puertas correderas
Самонесущая тележка 5 колес для откидных ворот

CARATTERISTICHE

- Corpo multistrato brevettato
- Cuscinetti silenziosi di nuova generazione schermati per una migliore protezione dalla polvere; adatti a temperature che vanno dai -30° ai +80°
- 4 ruote di supporto per ogni carrello
- Ruota centrale di allineamento
- Perno centrale di rotazione

FEATURES

- Patented multiplate body
- Noiseless bearings of new generation shielded to protect against dust suitable for temperatures from -30° C to +80° C
- 4 support wheels for each carriage
- Alignment Central wheel
- Central rotation pin

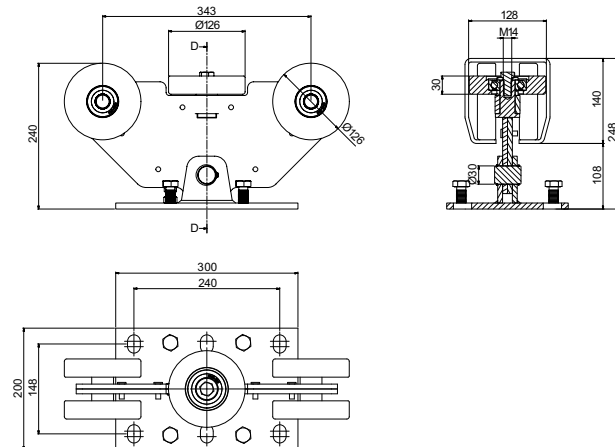

PATENTED

CODE	ART.	Size	Box info	
			Pcs per pack	Kg
10130032 001	CGS-250.5 G	Grande	1	26,6

Finishing: Zincato / Galvanized

Categoria commerciale: 10

Dimensioni minime getto cemento armato
Minimum dimensions of the reinforced concrete casting
Dimensions minimums du coulage du ciment armé
Mindestgröße des Stahlbetonguss
Dimensiones mínimas colada cemento armado
Минимальные размеры железобетонной стяжки

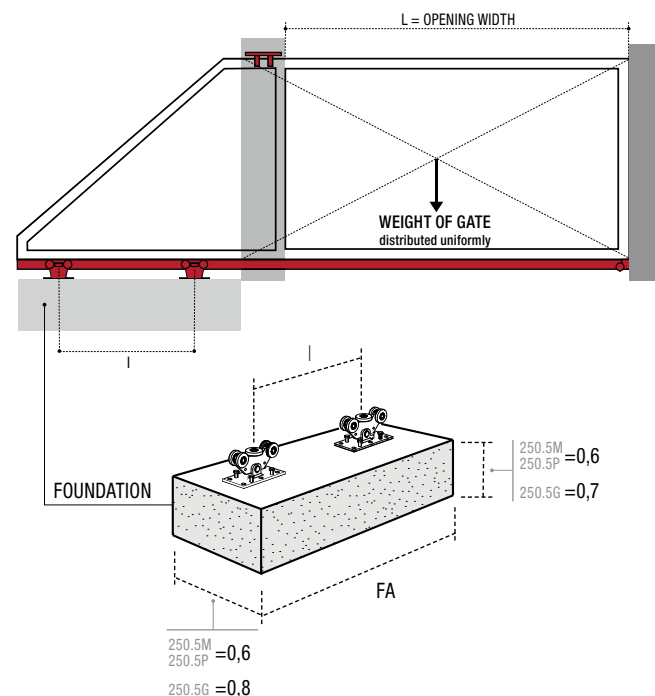

CGS 250.5 Grande (F1max=1400 Kg)										
Weight (Kg)	L=5 m		L=5,5 m		L=6 m		L=6,5 m		L=7 m	
	FA (M)	I (M)	FA (M)	I (M)	FA (M)	I (M)	FA (M)	I (M)	FA (M)	I (M)
300	2,20	1,30	2,40	1,50	2,60	1,70	2,70	1,80	2,90	2,00
350	2,50	1,60	2,70	1,80	2,90	2,00	3,10	2,20	3,30	2,40
400	2,70	1,80	3,00	2,10	3,20	2,30	3,50	2,60	3,70	2,80
450	3,10	2,20	3,30	2,40	3,60	2,70	3,90	3,00	4,20	3,30

CGS-245G

Monorotaia per cancelli auto-portanti
Monorail for cantilever gates
Rais pour portails autoportants
Einfachschiene für selbsttragende Tore
Monocaril para puertas autoportantes
Монорельс для самонесущих ворот

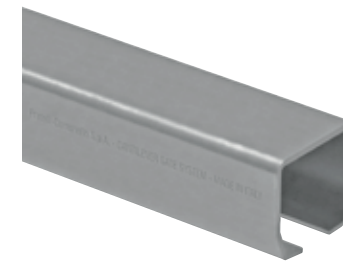

CODE	ART.	Size	Finishing	A	B	C	H	S	L	Box info	
										Pcs per pack	Kg
10207014	CGS-245G	Grande	Raw	98	140	38	140	6	3000	1	67,0
10207026	CGS-245G	Grande	Raw	98	140	38	140	6	6000	1	134,0
10207014 001	CGS-245G	Grande	Zinc	98	140	38	140	6	3000	1	67,0
10207026 001	CGS-245G	Grande	Zinc	98	140	38	140	6	6000	1	134,0

Categoria commerciale: 1R

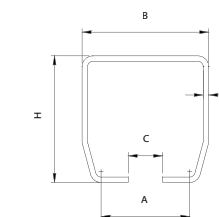

CGS-346G

Incontro inferiore a fissare
Bottom end cup to be fixed
Butée inférieure à fixer
Unteraufлагesohuh zum Aufschrauben
Encuentro inferior para fijar
Прикрепляемый нижний упор



CODE	ART.	Size	A	B	C	D	E	F	G	H	I	S	Box info	
													Pcs per pack	Kg
10705510 001	CGS-346G	Grande	159	154	35	13	120	197	55	165	77	5	2	7,6

Finishing: Zincato / Galvanized

Categoria commerciale: 1T

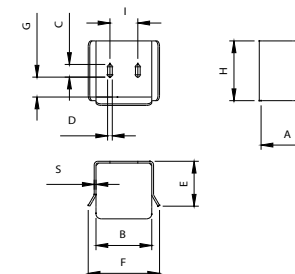

CGS-347G

Ruota terminale per monorotaia
End wheel for monorail
Galet d'extrémité pour rail
Endrad für Einfachschiene
Rueda terminal para monocaril
Концевое колесо монорельса



CODE	ART.	Size	A	B	C	D	E	F	G	H	L	M	N	S	Box info	
															Pcs per pack	Kg
10705010 001	CGS-347G	Grande	195	140	155	Ø98	170	24,5	15	140	95	56	30	5	2	8,3

Finishing: Zincato / Galvanized

Categoria commerciale: 1T

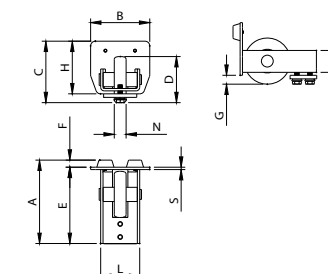



CGS-250.8 Mini

Carrello auto-portante 8 ruote per cancelli a sbalzo
8 wheels cantilever carriage for gates
Chariot autoportant 8 roues pour portails
8-rädriger Laufwagen für freitragende Tore
Carro autoportante 8 ruedas para puertas correderas
Самонесущая тележка 8 колес для откидных ворот



CARATTERISTICHE

- Corpo multi-forma brevettato
- Cuscinetti silenziosi di nuova generazione schermati per una migliore protezione dalla polvere; adatti a temperature che vanno dai -30° ai +80°
- Autobilanciato
- 8 ruote di supporto per ogni carrello
- Allineamento longitudinale su 16 ruote
- Perno centrale di rotazione

FEATURES

- Patented multiplate body
- Noiseless bearings of new generation shielded to protect against dust suitable for temperatures from -30° C to + 80° C
- Self-balancing
- 8 support wheels for each carriage
- Longitudinal alignment on 16 wheels
- Central rotation stiffened pin

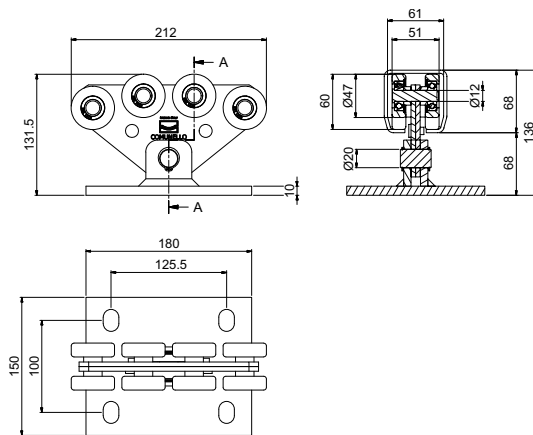

CODE	ART.	Size	Box info	
			Pcs per pack	Kg
10130003 001	CGS-250.8 M	Mini	1	5,0

Finishing: Zincato / Galvanized

Categoria commerciale: 10

Dimensioni minime getto cemento armato
Minimum dimensions of the reinforced concrete casting
Dimensions minimums du coulage du ciment armé
Mindestgröße des Stahlbetonguss
Dimensiones mínimas colada cemento armado
Минимальные размеры железобетонной стяжки

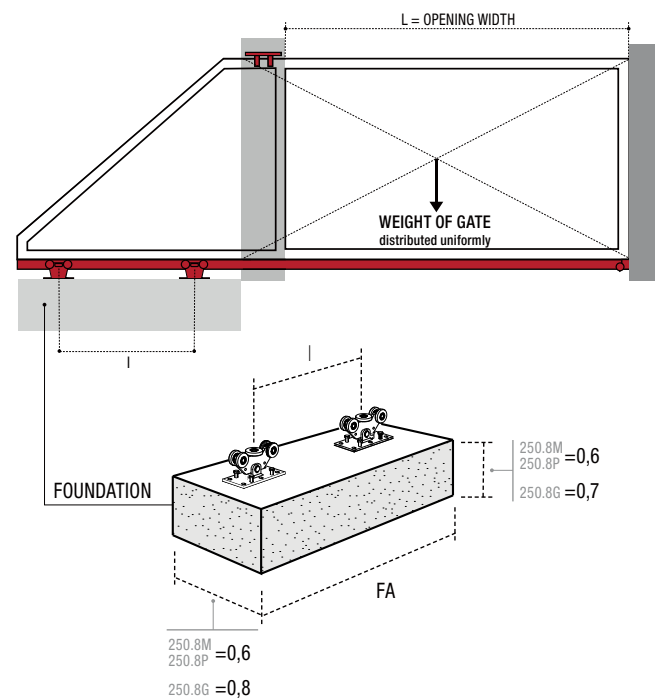

Weight (Kg)	CGS 250.8 Mini (F1 max=950 Kg)							
	L=2 m		L=2,5 m		L=3 m		L=3,5 m	
	FA (M)	I (M)	FA (M)	I (M)	FA (M)	I (M)	FA (M)	I (M)
200	1,10	0,50	1,20	0,60	1,30	0,70	1,50	0,90
250	1,30	0,70	1,40	0,80	1,50	0,90	1,80	1,20
300	1,50	0,90	1,60	1,00	1,80	1,20	2,10	1,50
350	1,70	1,10	1,90	1,30	2,10	1,50	2,50	1,90

CGS-245M

Monorotaia per cancelli auto-portanti
Monorail for cantilever gates
Rails pour portails autoportants
Einfachschiene für selbsttragende Tore
Monocaril para puertas autoportantes
Монорельс для самонесущих ворот

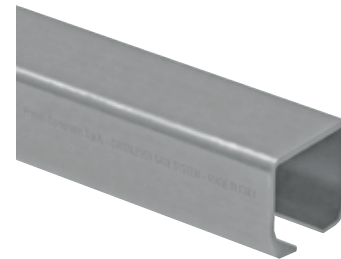

CODE	ART.	Size	Finishing	A	B	C	H	S	L	Box info	
										Pcs per pack	Kg
10207004	CGS-245M	Mini	Raw	48	68	23	68	3,5	3000	1	18,3
10207024	CGS-245M	Mini	Raw	48	68	23	68	3,5	6000	1	36,5
10207004 001	CGS-245M	Mini	Zinc	48	68	23	68	3,5	3000	1	18,3
10207024 001	CGS-245M	Mini	Zinc	48	68	23	68	3,5	6000	1	36,5

Categoria commerciale: 1R

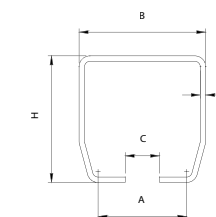

CGS-346M

Incontro inferiore a fissare
Bottom end cup to be fixed
Butée inférieure à fixer
Unterauflageschuh zum Aufschrauben
Encuentro inferior para fijar
Прикрепляемый нижний упор



CODE	ART.	Size	A	B	C	D	E	F	G	H	I	S	Box info	
													Pcs per pack	Kg
10705501 001	CGS-346M	Mini	104	78	25	9	75	114	25	91	38	4	2	2,3

Finishing: Zincato / Galvanized

Categoria commerciale: 1T

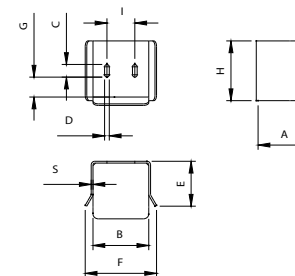

CGS-347M

Ruota terminale per monorotaia
End wheel for monorail
Galet d'extrémité pour rail
Endrad für Einfachschiene
Rueda terminal para monocaril
Концевое колесо монорельса



CODE	ART.	Size	A	B	C	D	E	F	G	H	L	M	N	S	Box info	
															Pcs per pack	Kg
10705001 001	CGS-347M	Mini	135	68	82,5	Ø68	123	12	14,5	68	45	32	15	4	2	2,0

Finishing: Zincato / Galvanized

Categoria commerciale: 1T

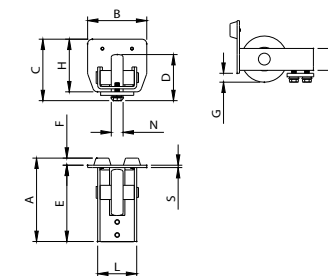



CGS-250.8 Piccolo

Carrello auto-portante 8 ruote per cancelli a sbalzo
8 wheels cantilever carriage for gates
Chariot autoportant 8 roues pour portails
8-rädiger Laufwagen für freitragende Tore
Carro autoportante 8 ruedas para puertas correderas
Самонесущая тележка 8 колес для откидных ворот

CARATTERISTICHE

- Corpo multi-forma brevettato
- Cuscinetti silenziosi di nuova generazione schermati per una migliore protezione dalla polvere; adatti a temperature che vanno dai -30° ai +80°
- Autobilanciato
- 8 ruote di supporto per ogni carrello
- Allineamento longitudinale su 16 ruote
- Perno centrale di rotazione

FEATURES

- Patented multiplate body
- Noiseless bearings of new generation shielded to protect against dust suitable for temperatures from -30° C to + 80° C
- Self-balancing
- 8 support wheels for each carriage
- Longitudinal alignment on 16 wheels
- Central rotation stiffened pin

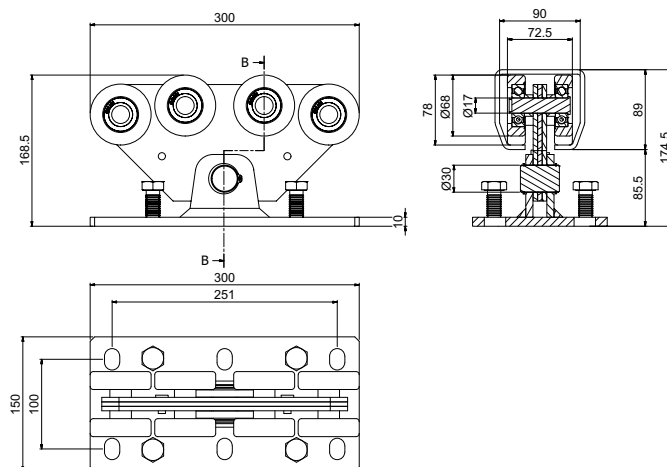

CODE	ART.	Size	Box info	
			Pcs per pack	Kg
10130007 001	CGS-250.8 P	Piccolo	1	10,6

Finishing: Zincato / Galvanized

Categoria commerciale: 10

Dimensioni minime getto cemento armato
Minimum dimensions of the reinforced concrete casting
Dimensions minimums du coulage du ciment armé
Mindestgröße des Stahlbetonguss
Dimensiones mínimas colada cemento armado
Минимальные размеры железобетонной стяжки

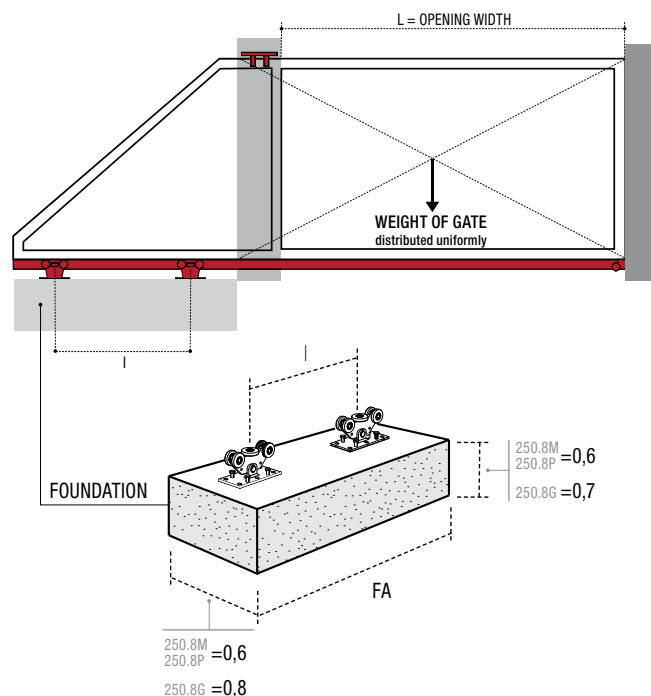

CGS 250.8 Piccolo (F1 max=1550 Kg)										
Weight (Kg)	L=2,5 m		L=3 m		L=3,5 m		L=4 m		L=4,5 m	
	FA (M)	I (M)	FA (M)	I (M)	FA (M)	I (M)	FA (M)	I (M)	FA (M)	I (M)
400	1,40	0,70	1,50	0,90	1,70	1,00	1,80	1,10	1,90	1,20
450	1,60	0,90	1,70	1,00	1,80	1,10	2,00	1,30	2,10	1,40
500	1,70	1,00	1,80	1,20	2,00	1,30	2,20	1,50	2,30	1,60
550	1,80	1,10	2,00	1,30	2,20	1,50	2,40	1,70	2,60	1,90
600	2,00	1,30	2,20	1,50	2,40	1,70	2,60	1,90	2,90	2,20

CGS-245P

Monorotaia per cancelli auto-portanti
Monorail for cantilever gates
Rais pour portails autoportants
Einfachschiene für selbsttragende Tore
Monocaril para puertas autoportantes
Монорельс для самонесущих ворот

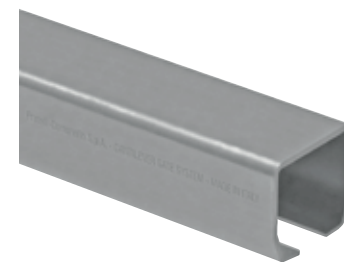

CODE	ART.	Size	Finishing	A	B	C	H	S	L	Box info	
										Pcs per pack	Kg
10207006	CGS-245P	Piccolo	Raw	66,5	100	33	89	5	3000	1	35,0
10207025	CGS-245P	Piccolo	Raw	66,5	100	33	89	5	6000	1	70,0
10207006 001	CGS-245P	Piccolo	Zinc	66,5	100	33	89	5	3000	1	35,0
10207025 001	CGS-245P	Piccolo	Zinc	66,5	100	33	89	5	6000	1	70,0

Categoria commerciale: 1R

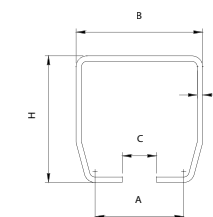

CGS-346P

Incontro inferiore a fissare
Bottom end cup to be fixed
Butée inférieure à fixer
Unterauflegesoh zum Aufschrauben
Encuentro inferior para fijar
Прикрепляемый нижний упор



CODE	ART.	Size	A	B	C	D	E	F	G	H	I	S	Box info	
													Pcs per pack	Kg
10705505 001	CGS-346P	Piccolo	119	112	30	11	84	154	33	112	50	4	2	3,6
10706005	CGI-346P	Piccolo	119	112	30	11	84	154	33	112	50	4	2	3,6

Finishing: Zincato / Galvanized

Finishing: Inox / Stainless steel

Categoria commerciale: 1T

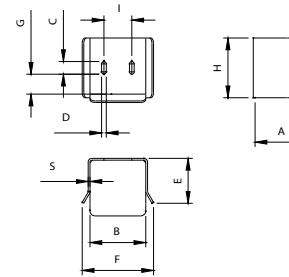

CGS-347P

Ruota terminale per monorotaia
End wheel for monorail
Galet d'extrémité pour rail
Endrad für Einfachschiene
Rueda terminal para monocaril
Концевое колесо монорельса



CODE	ART.	Size	A	B	C	D	E	F	G	H	L	M	N	S	Box info	
															Pcs per pack	Kg
10705005 001	CGS-347P	Piccolo	141	100	104	Ø78	129	12	15	89	66	37	20	4	2	3,4
10705305	CGI-347P	Piccolo	141	100	104	Ø78	129	12	15	89	66	37	20	4	2	3,4

Finishing: Zincato / Galvanized

Finishing: Inox / Stainless steel

Categoria commerciale: 1T

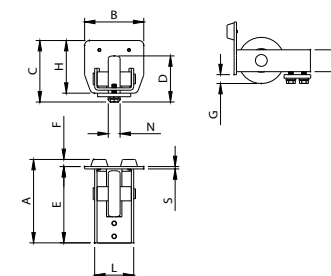



CGS-250.8 Grande

Carrello auto-portante 8 ruote per cancelli a sbalzo
8 wheels cantilever carriage for gates
Chariot autoportant 8 roues pour portails
8-rädriger Laufwagen für freitragende Tore
Carro autoportante 8 ruedas para puertas correderas
Самонесущая тележка 8 колес для откидных ворот



CARATTERISTICHE

- Corpo multi-forma brevettato
- Cuscinetti silenziosi di nuova generazione schermati per una migliore protezione dalla polvere; adatti a temperature che vanno dai -30° ai +80° C
- Autobilanciato
- 8 ruote di supporto per ogni carrello
- Allineamento longitudinale su 16 ruote
- Perno centrale di rotazione

FEATURES

- Patented multiplate body
- Noiseless bearings of new generation shielded to protect against dust suitable for temperatures from -30° C to +80° C
- Self-balancing
- 8 support wheels for each carriage
- Longitudinal alignment on 16 wheels
- Central rotation stiffened pin

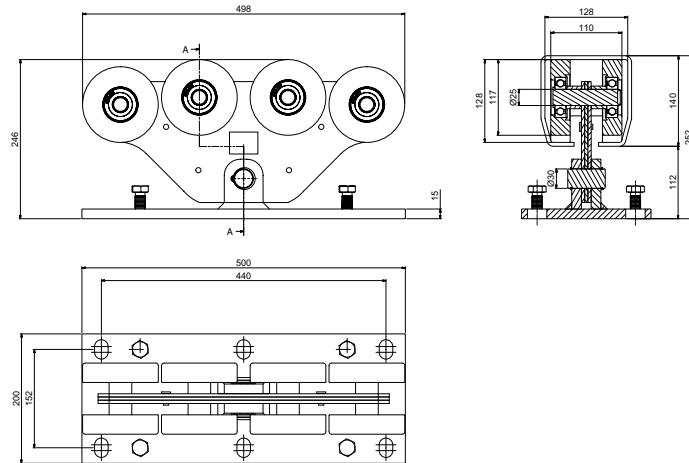

CODE	ART.	Size	Box info	
			Pcs per pack	Kg
10130012 001	CGS-250.8 G	Grande	1	26,6

Finishing: Zincato / Galvanized

Categoria commerciale: 10

Dimensioni minime getto cemento armato
Minimum dimensions of the reinforced concrete casting
Dimensions minimums du coulage du ciment armé
Mindestgröße des Stahlbetonguss
Dimensiones mínimas colada cemento armado
Минимальные размеры железобетонной стяжки

CGS 250.8 Grande (F1max=2500 Kg)										
Weight (Kg)	L=5 m		L=5,5 m		L=6 m		L=6,5 m		L=7 m	
	FA (M)	I (M)	FA (M)	I (M)	FA (M)	I (M)	FA (M)	I (M)	FA (M)	I (M)
500	1,90	1,00	2,00	1,10	2,10	1,20	2,30	1,40	2,40	1,50
550	2,00	1,10	2,10	1,20	2,30	1,40	2,40	1,50	2,50	1,60
600	2,10	1,20	2,30	1,40	2,40	1,50	2,60	1,70	2,70	1,80
650	2,30	1,40	2,40	1,50	2,60	1,70	2,70	1,80	2,90	2,00

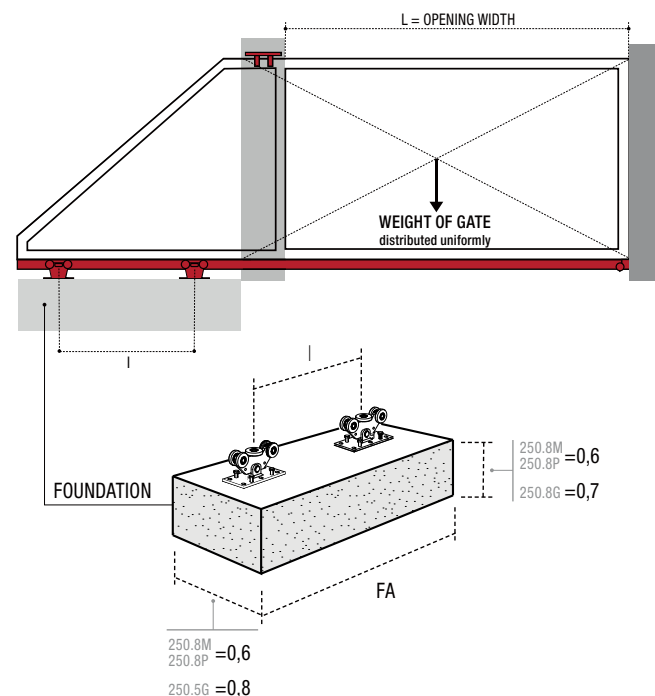

CGS-245G

Monorotaia per cancelli auto-portanti
Monorail for cantilever gates
Rais pour portails autoportants
Einfachschiene für selbsttragende Tore
Monocaril para puertas autoportantes
Монорельс для самонесущих ворот

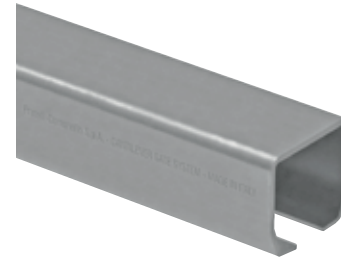

CODE	ART.	Size	Finishing	A	B	C	H	S	L	Box info	
										Pcs per pack	Kg
10207006	CGS-245P	Grande	Raw	98	140	38	140	6	3000	1	67,0
10207025	CGS-245P	Grande	Raw	98	140	38	140	6	6000	1	134,0
10207006 001	CGS-245P	Grande	Zinc	98	140	38	140	6	3000	1	67,0
10207023 001	CGS-245P	Grande	Zinc	98	140	38	140	6	6000	1	134,0

Categoria commerciale: 1R

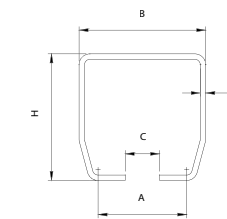

CGS-346G

Incontro inferiore a fissare
Bottom end cup to be fixed
Butée inférieure à fixer
Unteraufageschuh zum Aufschrauben
Encuentro inferior para fijar
Прикрепляемый нижний упор



CODE	ART.	Size	A	B	C	D	E	F	G	H	I	S	Box info	
													Pcs per pack	Kg
10705510 001	CGS-346G	Grande	159	154	35	13	120	197	55	165	77	5	2	7,6

Finishing: Zincato / Galvanized

Categoria commerciale: 1T

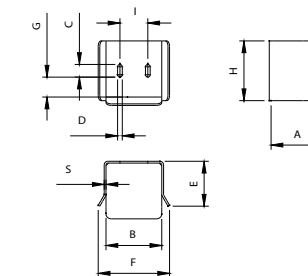

CGS-347G

Ruota terminale per monorotaia
End wheel for monorail
Galet d'extrémité pour rail
Endrad für Einfachschiene
Rueda terminal para monocaril
Концевое колесо монорельса



CODE	ART.	Size	A	B	C	D	E	F	G	H	L	M	N	S	Box info	
															Pcs per pack	Kg
10705010 001	CGS-347G	Grande	195	140	155	Ø98	170	24,5	15	140	95	56	30	5	2	8,3

Finishing: Zincato / Galvanized

Categoria commerciale: 1T

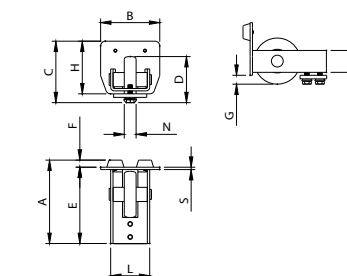



CGS-350.5 Mini

Carrello auto-portante 5 ruote per cancelli a sbalzo
5 wheels cantilever carriage for gates
Chariot autoportant 5 roues pour portails
5-rädriger Laufwagen für freitragende Tore
Carro autoportante 5 ruedas para puertas correderas
Самонесущая тележка 5 колес для откидных ворот



CARATTERISTICHE

- Corpo monoblocco che assicura resistenza alla struttura
- Indicato per i climi più umidi in quanto evita la corrosione del carrello
- Cuscinetti silenziosi di nuova generazione schermati per una migliore protezione dalla polvere; adatti a temperature che vanno dai -30° ai +80°
- 4 ruote di supporto per ogni carrello
- Ruota centrale di allineamento
- Perno centrale di rotazione

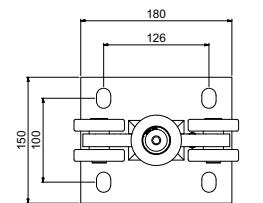
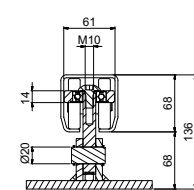
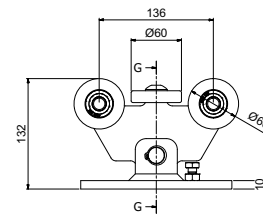

FEATURES

- Monoblock body that ensures strenght to the structure
- Suitable to humid climate to avoid the carriage corrosion
- Noiseless bearings of new generation shielded to protect against dust suitable for temperatures from -30 ° C to + 80 ° C
- 4 support wheels for each carriage
- Alignment Central wheel
- Central rotation pin

CODE	ART.	Size	Box info	
			Pcs per pack	Kg
10130001 001	CGS-350.5 M	Mini	1	5,2

Finishing: Zincato / Galvanized

Categoria commerciale: 10

Dimensioni minime getto cemento armato
Minimum dimensions of the reinforced concrete casting
Dimensions minimums du coulage du ciment armé
Mindestgröße des Stahlbetonguss
Dimensiones mínimas colada cemento armado
Минимальные размеры железобетонной стяжки

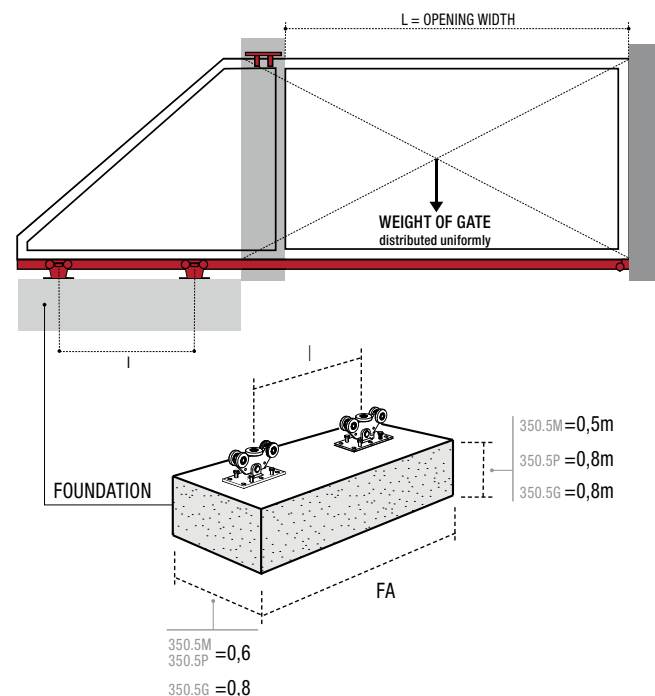

CGS 350.5 Mini (F1max=600 Kg)										
Weight (Kg)	L=3 m		L=3,5 m		L=4 m		L=4,5 m		L=5 m	
	FA (M)	I (M)	FA (M)	I (M)	FA (M)	I (M)	FA (M)	I (M)	FA (M)	I (M)
100	1,30	0,40	1,40	0,50	1,50	0,60	1,60	0,70	1,70	0,80
125	1,50	0,60	1,60	0,70	1,70	0,80	1,80	0,90	1,90	1,00
150	1,60	0,70	1,70	0,80	1,80	0,90	2,00	1,10	2,10	1,20
175	1,80	0,90	1,90	1,00	2,00	1,20	2,20	1,30	2,40	1,50
200	1,90	1,00	2,10	1,20	2,30	1,40	2,50	1,60	2,70	1,80
225	2,10	1,20	2,30	1,40	2,50	1,70	2,80	1,90	3,00	2,10
250	2,40	1,50	2,60	1,70	2,90	2,00	3,10	2,20	3,40	2,50

CGS-345M

Monorotaia per cancelli auto-portanti
Monorail for cantilever gates
Rais pour portails autoportants
Einfachschiene für selbsttragende Tore
Monocaril para puertas autoportantes
Монорельс для самонесущих ворот

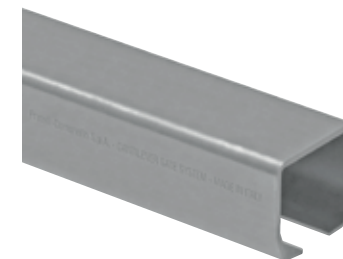

CODE	ART.	Size	Finishing	A	B	C	H	S	L	Box info	
										Pcs per pack	Kg
10207001	CGS-345M	Mini	Raw	48	68	23	68	3,5	3000	1	18,25
10207002	CGS-345M	Mini	Raw	48	68	23	68	3,5	6000	1	36,50
10207001 001	CGS-345M	Mini	Zinc	98	140	38	140	6	3000	1	67,0
10207002 001	CGS-345M	Mini	Zinc	98	140	38	140	6	6000	1	134,0

Categoria commerciale: 1R

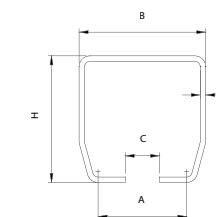

CGS-346M

Incontro inferiore a fissare
Bottom end cup to be fixed
Butée inférieure à fixer
Unteraufлагesohuh zum Aufschrauben
Encuentro inferior para fijar
Прикрепляемый нижний упор



CODE	ART.	Size	A	B	C	D	E	F	G	H	I	S	Box info	
													Pcs per pack	Kg
10705501 001	CGS-346M	Mini	104	78	25	9	75	114	25	91	38	4	2	2,3

Finishing: Zincato / Galvanized

Categoria commerciale: 1T

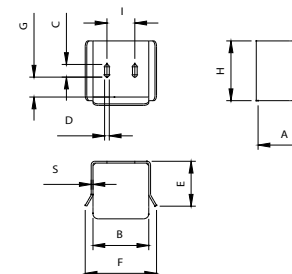

CGS-347M

Ruota terminale per monorotaia
End wheel for monorail
Galet d'extrémité pour rail
Endrad für Einfachschiene
Rueda terminal para monocaril
Концевое колесо монорельса



CODE	ART.	Size	A	B	C	D	E	F	G	H	L	M	N	S	Box info	
															Pcs per pack	Kg
10705001 001	CGS-347M	Mini	135	68	82,5	Ø68	123	12	14,5	68	45	32	15	4	2	2,0

Finishing: Zincato / Galvanized

Categoria commerciale: 1T

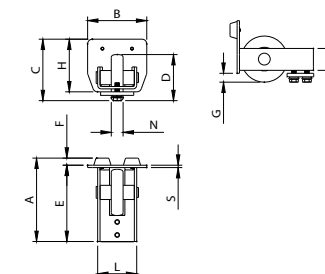



CGS-350.5 Piccolo

Carrello auto-portante 5 ruote per cancelli a sbalzo
5 wheels cantilever carriage for gates
Chariot autoportant 5 roues pour portails
5-rädriger Laufwagen für freitragende Tore
Carro autoportante 5 ruedas para puertas correderas
Самонесущая тележка 5 колес для откидных ворот



CARATTERISTICHE

- Corpo monoblocco che assicura resistenza alla struttura
- Indicato per i climi più umidi in quanto evita la corrosione del carrello
- Cuscinetti silenziosi di nuova generazione schermati per una migliore protezione dalla polvere; adatti a temperature che vanno dai -30° ai +80°
- 4 ruote di supporto per ogni carrello
- Ruota centrale di allineamento
- Perno centrale di rotazione

FEATURES

- Monoblock body that ensures strenght to the structure
- Suitable to humid climate to avoid the carriage corrosion
- Noiseless bearings of new generation shielded to protect against dust suitable for temperatures from -30 °C to + 80 °C
- 4 support wheels for each carriage
- Alignment Central wheel
- Central rotation pin

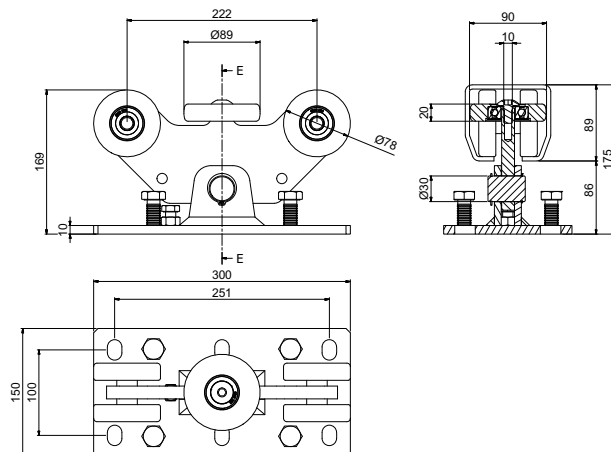

CODE	ART.	Size	Box info	
			Pcs per pack	Kg
10130005 001	CGS-350.5 P	Piccolo	1	11,0

Finishing: Zincato / Galvanized

Categoria commerciale: 10

Dimensioni minime getto cemento armato
Minimum dimensions of the reinforced concrete casting
Dimensions minimums du coulage du ciment armé
Mindestgröße des Stahlbetonguss
Dimensiones mínimas colada cemento armado
Минимальные размеры железобетонной стяжки

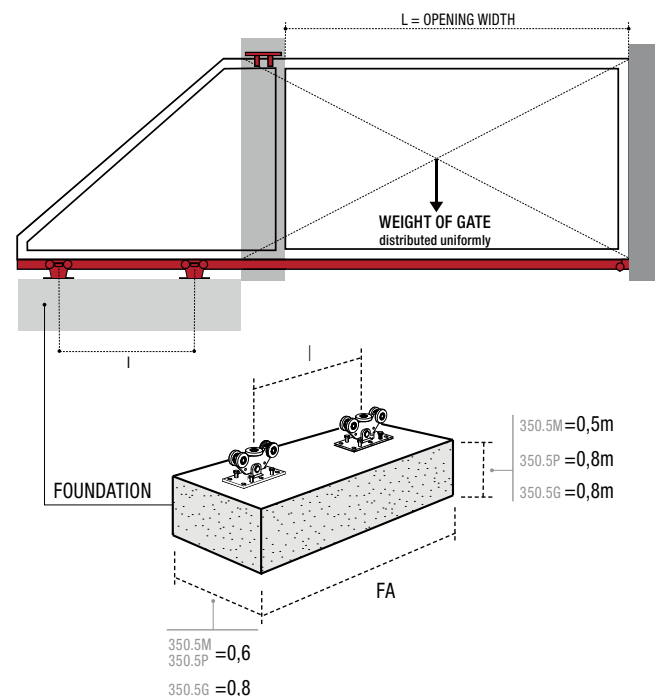

CGS 350.5 Piccolo (F1max=1000 Kg)										
Weight (Kg)	L=4 m		L=5 m		L=6 m		L=7 m		L=8 m	
	FA (m)	I (m)	FA (m)	I (m)	FA (m)	I (m)	FA (m)	I (m)	FA (m)	I (m)
250	1,70	1,00	2,00	1,30	2,30	1,60	2,70	2,00	3,10	2,40
275	1,80	1,10	2,20	1,50	2,50	1,80	2,90	2,20	3,30	2,60
300	2,00	1,30	2,30	1,60	2,70	2,00	3,20	2,50	3,60	3,00
325	2,10	1,40	2,50	1,80	3,00	2,30	3,50	2,80	4,00	3,30
350	2,30	1,60	2,70	2,00	3,20	2,50	3,80	3,10	4,40	3,70
375	2,50	1,80	3,00	2,30	3,50	2,80	4,10	3,40	4,80	4,10
400	2,70	2,00	3,20	2,50	3,80	3,10	4,50	3,80	5,20	4,60

CGS-345P

Monorotaia per cancelli auto-portanti
Monorail for cantilever gates
Rais pour portails autoportants
Einfachschiene für selbsttragende Tore
Monocaril para puertas autoportantes
Монорельс для самонесущих ворот

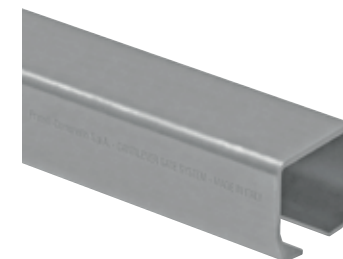

CODE	ART.	Size	Finishing	A	B	C	H	S	L	Box info	
										Pcs per pack	Kg
10207005	CGS-345P	Piccolo	Raw	66,5	100	33	89	5	3000	1	35,00
10207007	CGS-345P	Piccolo	Raw	66,5	100	33	89	5	6000	1	70,00
10207005 001	CGS-345P	Piccolo	Zinc	66,5	100	33	89	5	3000	1	35,00
10207007 001	CGS-345P	Piccolo	Zinc	66,5	100	33	89	5	6000	1	70,00
10207505	CGi-345P	Piccolo	Inox	66,5	100	33	89	5	3000	1	35,00
10207507	CGi-345P	Piccolo	Inox	66,5	100	33	89	5	6000	1	70,00

Categoria commerciale: 1R

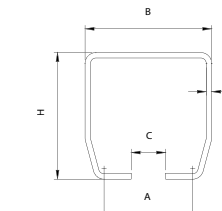

CGS-346P

Incontro inferiore a fissare
Bottom end cup to be fixed
Butée inférieure à fixer
Unteraufлагeschuh zum Aufschrauben
Encuentro inferior para fijar
Прикрепляемый нижний упор



CODE	ART.	Size	A	B	C	D	E	F	G	H	I	S	Box info	
													Pcs per pack	Kg
10705505 001	CGS-346P	Piccolo	119	112	30	11	84	154	33	112	50	4	2	3,6
10706005	CGi-346P	Piccolo	119	112	30	11	84	154	33	112	50	4	2	3,6

Finishing: Zincato / Galvanized

Finishing: Inox / Stainless steel

Categoria commerciale: 1T

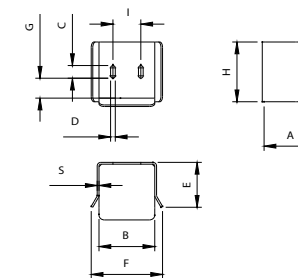

CGS-347P

Ruota terminale per monorotaia
End wheel for monorail
Galet d'extrémité pour rail
Endrad für Einfachschiene
Rueda terminal para monocaril
Концевое колесо монорельса



CODE	ART.	Size	A	B	C	D	E	F	G	H	L	M	N	S	Box info	
															Pcs per pack	Kg
10705005 001	CGS-347P	Piccolo	141	100	104	Ø78	129	12	15	89	66	37	20	4	2	3,4
10705305	CGi-347P	Piccolo	141	100	104	Ø78	129	12	15	89	66	37	20	4	2	3,4

Finishing: Zincato / Galvanized

Finishing: Inox / Stainless steel

Categoria commerciale: 1T

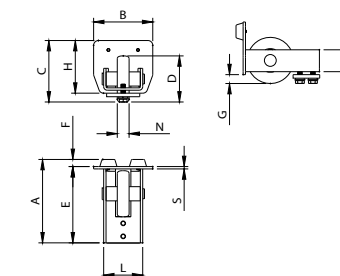



CGS-350.5 Grande

Carrello auto-portante 5 ruote per cancelli a sbalzo
5 wheels cantilever carriage for gates
Chariot autoportant 5 roues pour portails
5-rädriger Laufwagen für freitragende Tore
Carro autoportante 5 ruedas para puertas correderas
Самонесущая тележка 5 колес для откидных ворот



CARATTERISTICHE

- Corpo monoblocco che assicura resistenza alla struttura
- Indicato per i climi più umidi in quanto evita la corrosione del carrello
- Cuscinetti silenziosi di nuova generazione schermati per una migliore protezione dalla polvere; adatti a temperature che vanno dai -30° ai +80°
- 4 ruote di supporto per ogni carrello
- Ruota centrale di allineamento
- Perno centrale di rotazione

FEATURES

- Monoblock body that ensures strenght to the structure
- Suitable to humid climate to avoid the carriage corrosion
- Noiseless bearings of new generation shielded to protect against dust suitable for temperatures from -30 ° C to + 80 ° C
- 4 support wheels for each carriage
- Alignment Central wheel
- Central rotation pin

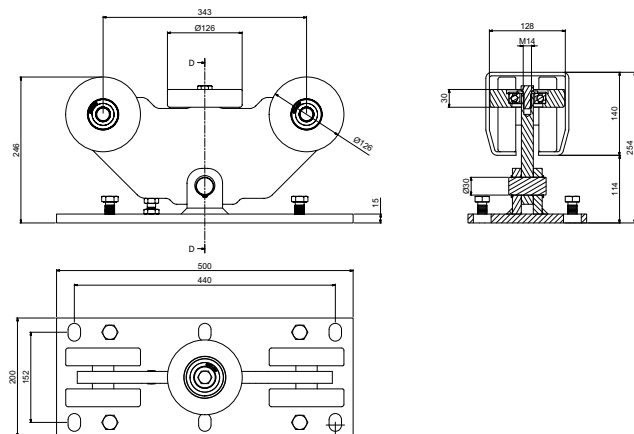

CODE	ART.	Size	Box info	
			Pcs per pack	Kg
10130010 001	CGS-350.5 G	Grande	1	26,6

Finishing: Zincato / Galvanized

Categoria commerciale: 10

Dimensioni minime getto cemento armato
Minimum dimensions of the reinforced concrete casting
Dimensions minimums du coulage du ciment armé
Mindestgröße des Stahlbetonguss
Dimensiones mínimas colada cemento armado
Минимальные размеры железобетонной стяжки

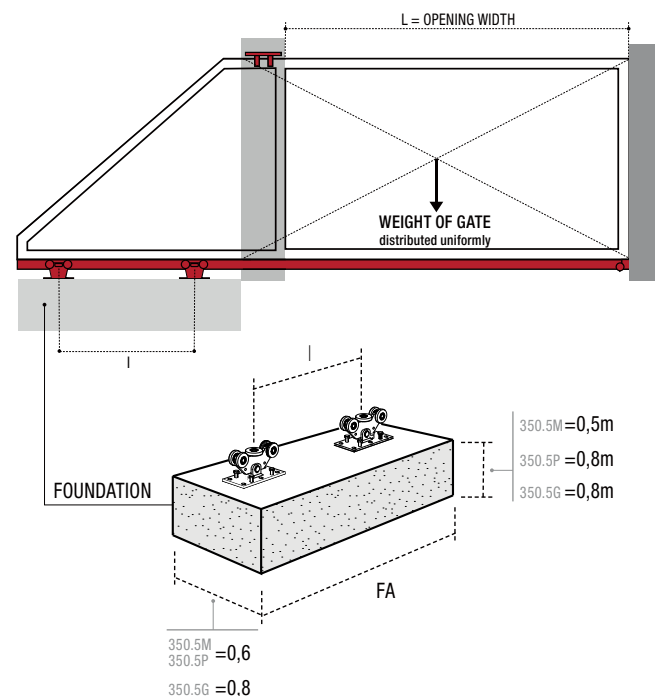

CGS 350.5 Grande (F1max=2000 Kg)											
Weight (Kg)	L=6 m		L=7 m		L=8 m		L=9 m		L=10 m		
	FA (M)	I (M)	FA (M)	I (M)	FA (M)	I (M)	FA (M)	I (M)	FA (M)	I (M)	
400	2,20	1,30	2,50	1,60	2,80	1,90	3,10	2,20	3,50	2,60	
450	2,40	1,50	2,70	1,80	3,00	2,10	3,40	2,50	3,80	2,90	
500	2,60	1,70	2,90	2,00	3,30	2,40	3,70	2,80	4,10	3,20	
550	2,80	1,90	3,20	2,30	3,60	2,70	4,00	3,10	4,50	3,60	
600	3,00	2,10	3,40	2,50	3,90	3,00	4,40	3,50	4,90	4,00	
650	3,20	2,40	3,70	2,80	4,20	3,30	4,80	3,90	5,40	4,50	
700	3,50	2,60	4,00	3,10	4,60	3,70	5,20	4,30	5,90	5,00	

CGS-345G

Monorotaia per cancelli auto-portanti
Monorail for cantilever gates
Rais pour portails autoportants
Einfachschiene für selbsttragende Tore
Monocaril para puertas autoportantes
Монорельс для самонесущих ворот

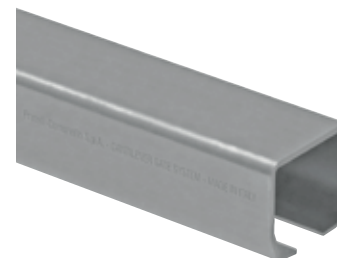

CODE	ART.	Size	Finishing	A	B	C	H	S	L	Box info	
										Pcs per pack	Kg
10207020	CGS-345G	Grande	Raw	98	140	38	140	6	3000	1	67,0
10207022	CGS-345G	Grande	Raw	98	140	38	140	6	6000	1	134,0
10207020 001	CGS-345G	Grande	Zinc	98	140	38	140	6	3000	1	67,0
10207022 001	CGS-345G	Grande	Zinc	98	140	38	140	6	6000	1	134,0

Categoria commerciale: 1R

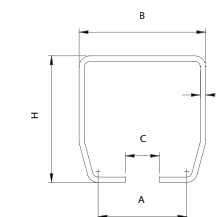

CGS-346G

Incontro inferiore a fissare
Bottom end cup to be fixed
Butée inférieure à fixer
Unteraufлагesoh zu Aufschrauben
Encuentro inferior para fijar
Прикрепляемый нижний упор



CODE	ART.	Size	A	B	C	D	E	F	G	H	I	S	Box info	
													Pcs per pack	Kg
10705510 001	CGS-346G	Grande	159	154	35	13	120	197	55	165	77	5	2	7,6

Finishing: Zincato / Galvanized

Categoria commerciale: 1T

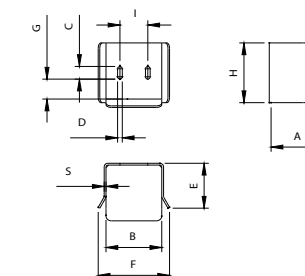

CGS-347G

Ruota terminale per monorotaia
End wheel for monorail
Galet d'extrémité pour rail
Endrad für Einfachschiene
Rueda terminal para monocaril
Концевое колесо монорельса



CODE	ART.	Size	A	B	C	D	E	F	G	H	L	M	N	S	Box info	
															Pcs per pack	Kg
10705010 001	CGS-347G	Grande	195	140	155	Ø98	170	24,5	15	140	95	56	30	5	2	8,3

Finishing: Zincato / Galvanized

Categoria commerciale: 1T

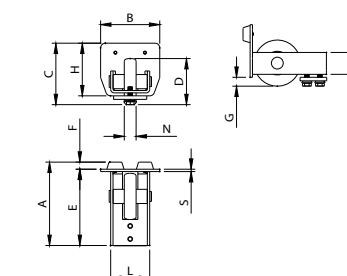



CGA-350.5 AL Mini Aluminium

Carrello autoportante 5 ruote in nylon per cancelli a sbalzo

5 nylon wheels cantilever carriage for gates
Chariot autoportant 5 roues en nylon pour portails
Laufwagen mit 5 Nylon-Rollen für freitragende Tore
Carro autoportante 5 ruedas de nylon para puertas correderas
Самонесущая тележка 5 нейлоновых колес для откидных ворот

CARATTERISTICHE

- Corpo monoblocco che assicura resistenza alla struttura
- Indicato per i climi più umidi in quanto evita la corrosione del carrello
- I cuscinetti di nuova generazione schermati e silenziosi proteggono i carrelli dalla polvere; adatti a temperature che vanno dai -20° ai +60°.
- 4 ruote di supporto in nylon per monorotaia in alluminio
- Rotella centrale di allineamento
- Perno centrale di rotazione

FEATURES

- Monoblock body that ensures strenght to the structure.
- Suitable to the humid climate to avoid the carriage corrosion
- Noiseless bearings of new generation shielded to protect against dust suitable for temperatures from -20 ° C to + 60 ° C
- 4 support nylon wheels specifically for aluminum monorail
- Alignment central wheel
- Central rotation pin

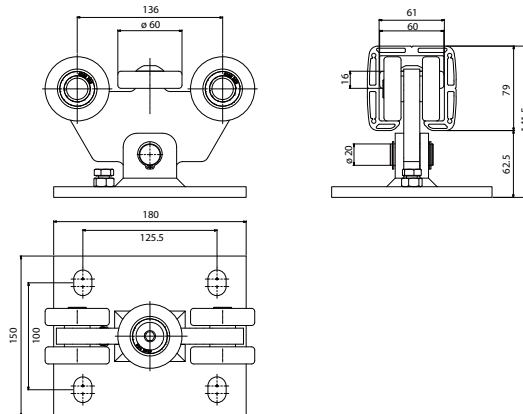

CODE	ART.	Size	Box info	
			Pcs per pack	Kg
10130600 001	CGA-350.5 AL M	Mini	1	4,5

Finishing: Zincato / Galvanized

Categoria commerciale: 10

Dimensioni minime getto cemento armato
Minimum dimensions of the reinforced concrete casting
Dimensions minimums du coulage du ciment armé
Mindestgröße des Stahlbetonguss
Dimensiones mínimas colada cemento armado
Минимальные размеры железобетонной стяжки

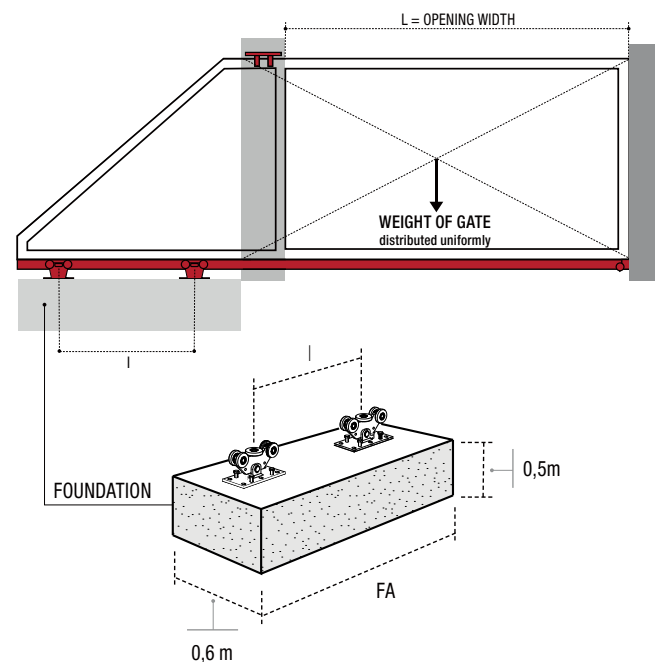

CGA 350.5 Mini (F1max=600 Kg)										
Weight (Kg)	L=3 m		L=3,5 m		L=4 m		L=4,5 m		L=5 m	
	FA (M)	I (M)	FA (M)	I (M)	FA (M)	I (M)	FA (M)	I (M)	FA (M)	I (M)
100	1,30	0,40	1,40	0,50	1,50	0,60	1,60	0,70	1,70	0,80
125	1,50	0,60	1,60	0,70	1,70	0,80	1,80	0,90	1,90	1,00
150	1,60	0,70	1,70	0,80	1,80	0,90	2,00	1,10	2,10	1,20
175	1,80	0,90	1,90	1,00	2,00	1,20	2,20	1,30	2,40	1,50
200	1,90	1,00	2,10	1,20	2,30	1,40	2,50	1,60	2,70	1,80
225	2,10	1,20	2,30	1,40	2,50	1,70	2,80	1,90	3,00	2,10
250	2,40	1,50	2,60	1,70	2,90	2,00	3,10	2,20	3,40	2,50

CGA-345M

Monorotaia per cancelli auto-portanti

Monorail for cantilever gates
Rails pour portails autoportants
Einfachschiene für selbsttragende Tore
Monocarri para puertas autoportantes
Монорельс для самонесущих ворот



CODE	ART.	Size	Finishing	A	B	C	H	L	Box info	
									Pcs per pack	Kg
10208 001	CGA-345M	Mini	Raw	61	83	23	79	3000	1	12,0
10208 003	CGA-345M	Mini	Raw	61	83	23	79	6000	1	24,0

Finishing: Alluminio / Aluminium

Categoria commerciale: 1R

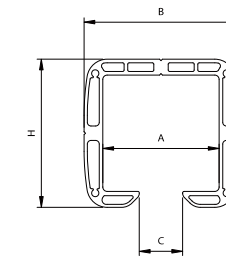

CGA-346M

Incontro inferiore a fissare

Bottom end cup to be fixed
Butée inférieure à fixer
Unterauflegesoh zum Aufschrauben
Encuentro inferior para fijar
Прикрепляемый нижний упор



CODE	ART.	Size	A	B	C	D	E	F	G	H	I	S	Box info	
													Pcs per pack	Kg
10705501 001	CGA-346M	Mini	84	92	30	11	80	132	27	100	50	4	2	2,3

Finishing: Zincato / Galvanized

Categoria commerciale: 1T

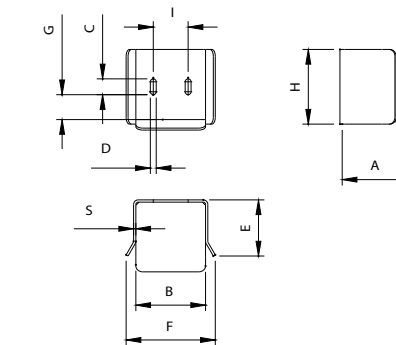

CGA-347M

Ruota terminale in nylon per monorotaia in alluminio

Nylon end wheel for aluminium monorail
Galet d'extrémité en nylon pour rail en aluminium
Nylon-Endrolle für Einfachschiene aus Aluminium
Rueda terminal de nylon para monocarril de aluminio
Концевое колесо из нейлона для алюминиевого монорельса



CODE	ART.	Size	A	B	C	D	E	F	G	H	L	M	N	Box info	
														Pcs per pack	Kg
10705200 001	CGA-347P	Mini	140	106,5	118	Ø79	125	15	9,6	102,5	66	37	26	2	3,4

Finishing: Zincato / Galvanized

Categoria commerciale: 1T

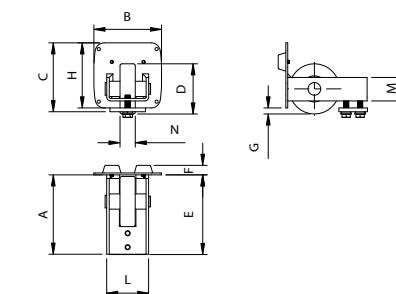



CGA-350.5 AL Piccolo Aluminium

Carrello autoportante 5 ruote in nylon per cancelli a sbalzo
5 nylon wheels cantilever carriage for gates
Chariot autoportant 5 roues en nylon pour portails
Laufwagen mit 5 Nylon-Rollen für freitragende Tore
Carro autoportante 5 ruedas de nylon para puertas correderas
Самонесущая тележка 5 нейлоновых колес для откидных ворот



CARATTERISTICHE

- Corpo monoblocco che assicura resistenza alla struttura
- Indicato per i climi più umidi in quanto evita la corrosione del carrello
- I cuscinetti di nuova generazione schermati e silenziosi proteggono i carrelli dalla polvere; adatti a temperature che vanno dai -20° ai +60°.
- 4 ruote di supporto in nylon per monorotaia in alluminio
- Rotella centrale di allineamento
- Perno centrale di rotazione

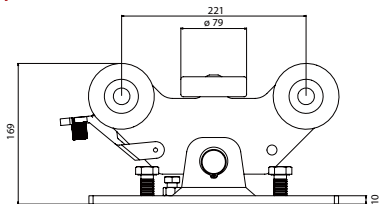

FEATURES

- Monoblock body that ensures strength to the structure.
- Suitable to the humid climate to avoid the carriage corrosion
- Noiseless bearings of new generation shielded to protect against dust suitable for temperatures from -20 °C to +60 °C
- 4 support nylon wheels specifically for aluminum monorail
- Alignment central wheel
- Central rotation pin

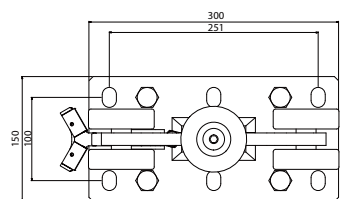
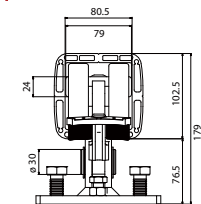

CODE	ART.	Size	Box info	
			Pcs per pack	Kg
10130605 001	CGA-350.5 AL P	Piccolo	1	8,3

Finishing: Zincato / Galvanized

Categoria commerciale: 10

Dimensioni minime getto cemento armato
Minimum dimensions of the reinforced concrete casting
Dimensions minimums du coulage du ciment armé
Mindestgröße des Stahlbetonguss
Dimensiones mínimas colada cemento armado
Минимальные размеры железобетонной стяжки

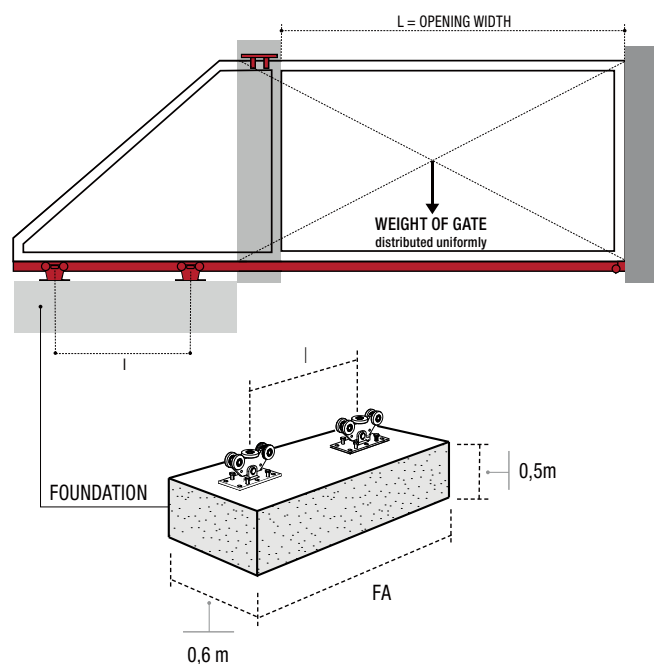

CGA 350.5 Piccolo Alluminio (F1 max=1000 Kg)										
Weight (Kg)	L=2,5 m		L=3 m		L=3,5 m		L=4 m		L=4,5 m	
	FA (m)	I (m)	FA (m)	I (m)	FA (m)	I (m)	FA (m)	I (m)	FA (m)	I (m)
100	0,90	0,20	1,00	0,30	1,00	0,40	2,00	1,30	1,20	0,50
125	1,00	0,30	1,10	0,40	1,10	0,40	2,20	1,50	1,30	0,60
150	1,10	0,40	1,10	0,40	1,20	0,50	2,30	1,60	1,40	0,70
175	1,10	0,40	1,20	0,50	1,30	0,60	2,60	1,90	1,50	0,80
200	1,20	0,50	1,30	0,60	1,40	0,70	2,80	2,10	1,60	0,90
225	1,30	0,60	1,40	0,70	1,50	0,80	3,00	2,30	1,70	1,00
250	1,30	0,60	1,40	0,80	1,60	0,90	3,30	2,60	1,80	1,20
275	1,40	0,70	1,50	0,80	1,70	1,00	3,50	2,80	2,00	1,30
300	1,50	0,80	1,60	1,00	1,80	1,10	3,90	3,20	2,10	1,50

CGA-345P

Monorotaia per cancelli auto-portanti
Monorail for cantilever gates
Rails pour portails autoportants
Einfachschiene für selbsttragende Tore
Monocarril para puertas autoportantes
Монорельс для самонесущих ворот



CODE	ART.	Size	Finishing	A	B	C	H	L	Box info	
									Pcs per pack	Kg
10208 005	CGA-345P	Piccolo	Raw	80,5	106,5	30	102,5	3000	1	16,0
10208 007	CGA-345P	Piccolo	Raw	80,5	106,5	30	102,5	6000	1	32,0

Finishing: Alluminio / Aluminium

Categoria commerciale: 1R

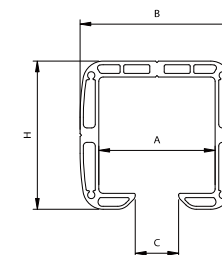

CGS-346P

Incontro inferiore a fissare
Bottom end cup to be fixed
Butée inférieure à fixer
Unterauflegesoh zum Aufschrauben
Encuentro inferior para fijar
Прикрепляемый нижний упор



CODE	ART.	Size	A	B	C	D	E	F	G	H	I	S	Box info	
													Pcs per pack	Kg
10705505 001	CGS-346P	Piccolo	119	112	30	11	84	154	33	112	50	4	2	3,6

Finishing: Zincato / Galvanized

CODE	ART.	Size	A	B	C	D	E	F	G	H	I	S	Box info	
													Pcs per pack	Kg
10706005	CGI-346P	Piccolo	119	112	30	11	84	154	33	112	50	4	2	3,6

Finishing: Inox / Stainless steel

Categoria commerciale: 1T

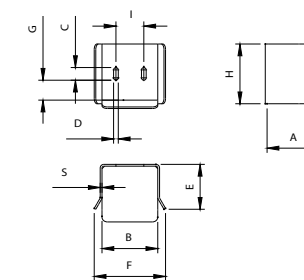

CGA-347P

Ruota terminale in nylon per monorotaia in alluminio
Nylon end wheel for aluminium monorail
Galet d'extrémité en nylon pour rail en aluminium
Nylon-Endrolle für Einfachschiene aus Aluminium
Rueda terminal de nylon para monocarril de aluminio
Концевое колесо из нейлона для алюминиевого монорельса



CODE	ART.	Size	A	B	C	D	E	F	G	H	L	M	N	Box info	
														Pcs per pack	Kg
10705205 001	CGA-347P	Piccolo	140	106,5	118	Ø79	125	15	9,6	102,5	66	37	26	2	3,4

Finishing: Zincato / Galvanized

Categoria commerciale: 1T

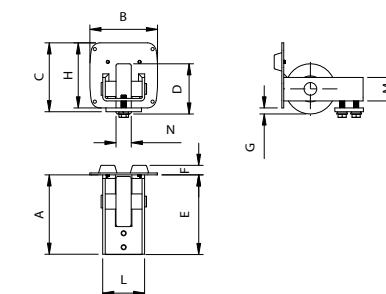



CGS-350.8 Mini

Carrello auto-portante 8 ruote per cancelli a sbalzo
8 wheels cantilever carriage for gates
Chariot autoportant 8 roues pour portails
8-rädriger Laufwagen für freitragende Tore
Carro autoportante 8 ruedas para puertas correderas
Самонесущая тележка 8 колес для откидных ворот



CARATTERISTICHE

- Corpo monoblocco che assicura resistenza alla struttura
- Indicato per i climi più umidi in quanto evita la corrosione del carrello
- I cuscinetti di nuova generazione schermati e silenziosi proteggono i carrelli dalla polvere; adatti a temperature che vanno dai -30° ai +80°.
- Autobilanciato
- 8 ruote di supporto per ogni carrello
- Allineamento longitudinale su 16 ruote
- Perno centrale di rotazione

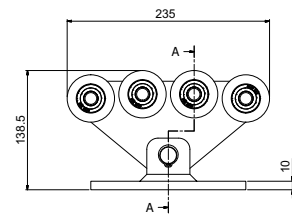

FEATURES

- Monoblock body that ensure strenght to the structure
- Suitable to the humid climate to avoid the carriage corrosion
- Noiseless bearings of new generation shielded to protect against dust suitable for temperatures from -30 ° C to + 80 ° C
- Self-balancing
- 8 support wheels for each carriage
- Longitudinal alignment on 16 wheels
- Central rotation pin

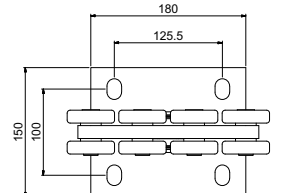
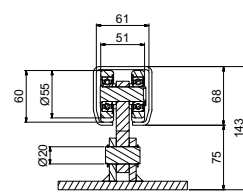

CODE	ART.	Size	Box info	
			Pcs per pack	Kg
10130002 001	CGS-350.8 M	Mini	1	5,2

Finishing: Zincato / Galvanized

Categoria commerciale: 10

Dimensioni minime getto cemento armato
Minimum dimensions of the reinforced concrete casting
Dimensions minimums du coulage du ciment armé
Mindestgröße des Stahlbetonguss
Dimensiones mínimas colada cemento armado
Минимальные размеры железобетонной стяжки

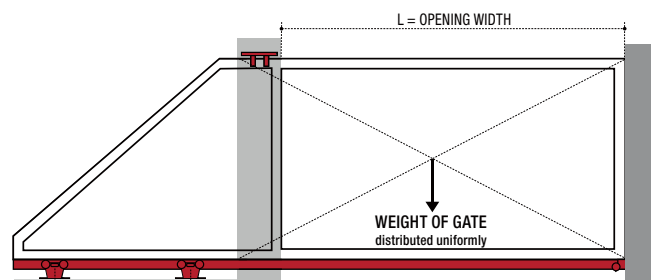

CGS 350.8 Mini (F1max=1200 Kg)										
Weight (Kg)	L=3 m		L=4 m		L=5 m		L=6 m		L=7 m	
	FA (M)	I (M)	FA (M)	I (M)	FA (M)	I (M)	FA (M)	I (M)	FA (M)	I (M)
100	1,10	0,20	1,20	0,30	1,20	0,30	1,30	0,40	1,40	0,50
150	1,20	0,30	1,30	0,40	1,40	0,50	1,50	0,60	1,60	0,70
200	1,30	0,40	1,40	0,50	1,60	0,70	1,70	0,80	1,90	1,00
250	1,40	0,50	1,60	0,70	1,80	0,90	1,90	1,00	2,10	1,20
300	1,50	0,60	1,70	0,90	2,00	1,10	2,20	1,30	2,40	1,50
350	1,70	0,80	1,90	1,00	2,20	1,30	2,50	1,60	2,80	1,90
400	1,90	1,00	2,20	1,30	2,50	1,60	2,80	1,90	3,10	2,20
450	2,00	1,10	2,40	1,50	2,80	1,90	3,20	2,30	3,60	2,70
500	2,30	1,40	2,70	1,80	3,10	2,20	3,60	2,70	4,10	3,20

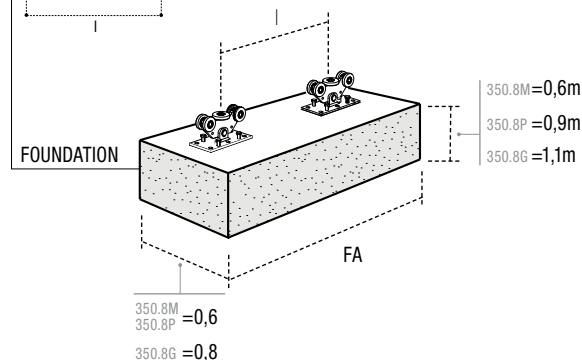

CGS-345M

Monorotaia per cancelli auto-portanti
Monorail for cantilever gates
Rais pour portails autoportants
Einfachschiene für selbsttragende Tore
Monocaril para puertas autoportantes
Монорельс для самонесущих ворот

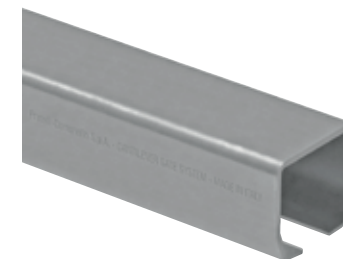

CODE	ART.	Size	Finishing	A	B	C	H	S	L	Box info	
										Pcs per pack	Kg
10207001	CGS-345M	Mini	Raw	48	68	23	68	3,5	3000	1	18,25
10207002	CGS-345M	Mini	Raw	48	68	23	68	3,5	6000	1	36,50
10207001 001	CGS-345M	Mini	Zinc	98	140	38	140	6	3000	1	67,0
10207002 001	CGS-345M	Mini	Zinc	98	140	38	140	6	6000	1	134,0

Categoria commerciale: 1R

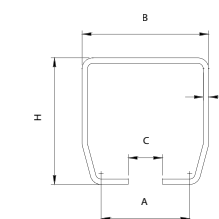

CGS-346M

Incontro inferiore a fissare
Bottom end cup to be fixed
Butée inférieure à fixer
Unteraufлагesohle zum Aufschrauben
Encuentro inferior para fijar
Прикрепляемый нижний упор



CODE	ART.	Size	A	B	C	D	E	F	G	H	I	S	Box info	
													Pcs per pack	Kg
10705501 001	CGS-346M	Mini	104	78	25	9	75	114	25	91	38	4	2	2,3

Finishing: Zincato / Galvanized

Categoria commerciale: 1T

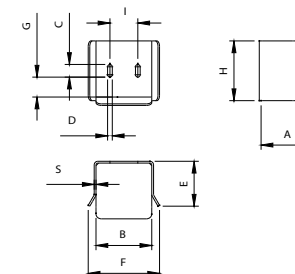

CGS-347M

Ruota terminale per monorotaia
End wheel for monorail
Galet d'extrémité pour rail
Endrad für Einfachschiene
Rueda terminal para monocaril
Концевое колесо монорельса



CODE	ART.	Size	A	B	C	D	E	F	G	H	L	M	N	S	Box info	
															Pcs per pack	Kg
10705001 001	CGS-347M	Mini	135	68	82,5	Ø68	123	12	14,5	68	45	32	15	4	2	2,0

Finishing: Zincato / Galvanized

Categoria commerciale: 1T

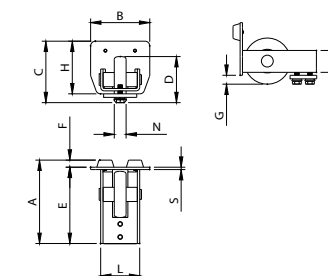



CGS-350.8 Piccolo

Carrello auto-portante 8 ruote per cancelli a sbalzo
8 wheels cantilever carriage for gates
Chariot autoportant 8 roues pour portails
8-rädriger Laufwagen für freitragende Tore
Carro autoportante 8 ruedas para puertas correderas
Самонесущая тележка 8 колес для откидных ворот



CARATTERISTICHE

- Corpo monoblocco che assicura resistenza alla struttura
- Indicato per i climi più umidi in quanto evita la corrosione del carrello
- I cuscinetti di nuova generazione schermati e silenziosi proteggono i carrelli dalla polvere; adatti a temperature che vanno dai -30° ai +80°.
- Autobilanciato
- 8 ruote di supporto per ogni carrello
- Allineamento longitudinale su 16 ruote
- Perno centrale di rotazione

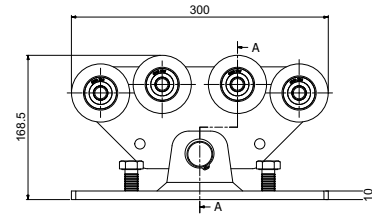

FEATURES

- Monoblock body that ensure strenght to the structure
- Suitable to the humid climate to avoid the carriage corrosion
- Noiseless bearings of new generation shielded to protect against dust suitable for temperatures from -30 ° C to + 80 ° C
- Self-balancing
- 8 support wheels for each carriage
- Longitudinal alignment on 16 wheels
- Central rotation pin

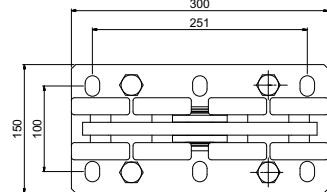
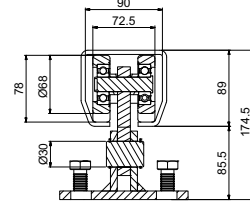

CODE	ART.	Size	Box info	
			Pcs per pack	Kg
10130006 001	CGS-350.8 P	Piccolo	1	12,0

Finishing: Zincato / Galvanized

Categoria commerciale: 10

Dimensioni minime getto cemento armato
Minimum dimensions of the reinforced concrete casting
Dimensions minimums du coulage du ciment armé
Mindestgröße des Stahlbetonguss
Dimensiones mínimas colada cemento armado
Минимальные размеры железобетонной стяжки

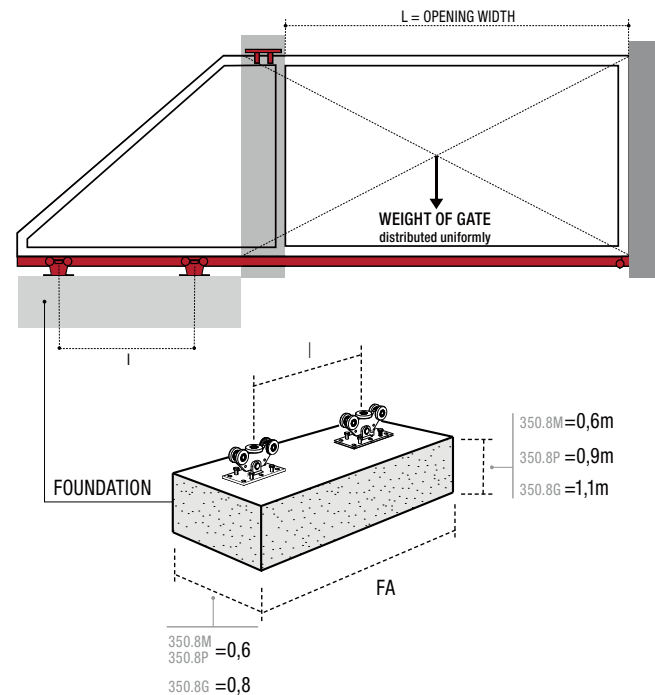

CGS 350.8 Piccolo (F1 max=2000 Kg)										
Weight (Kg)	L=4 m		L=5 m		L=6 m		L=7 m		L=8 m	
	FA (M)	I (M)	FA (M)	I (M)	FA (M)	I (M)	FA (M)	I (M)	FA (M)	I (M)
400	1,40	0,70	1,60	0,90	1,70	1,00	1,90	1,20	2,10	1,40
450	1,50	0,80	1,70	1,00	1,90	1,20	2,10	1,40	2,30	1,60
500	1,60	0,90	1,80	1,10	2,10	1,40	2,30	1,60	2,60	1,90
550	1,70	1,00	2,00	1,30	2,20	1,50	2,50	1,80	2,80	2,10
600	1,80	1,10	2,10	1,40	2,40	1,70	2,70	2,00	3,00	2,40
650	2,00	1,30	2,30	1,60	2,60	1,90	3,00	2,30	3,30	2,60
700	2,10	1,40	2,50	1,80	2,80	2,10	3,20	2,50	3,60	2,90
750	2,30	1,60	2,70	2,00	3,10	2,40	3,50	2,80	3,90	3,30
800	2,40	1,80	2,90	2,20	3,30	2,60	3,80	3,10	4,30	3,60

CGS-345P

Monorotaia per cancelli auto-portanti
Monorail for cantilever gates
Rais pour portails autoportants
Einfachschiene für selbsttragende Tore
Monocaril para puertas autoportantes
Монорельс для самонесущих ворот

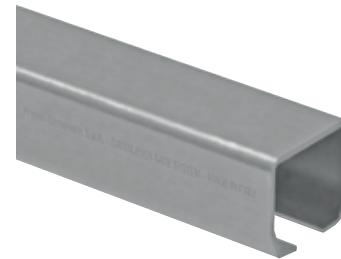

CODE	ART.	Size	Finishing	A	B	C	H	S	L	Box info	
										Pcs per pack	Kg
10207005	CGS-345P	Piccolo	Raw	66,5	100	33	89	5	3000	1	35,00
10207007	CGS-345P	Piccolo	Raw	66,5	100	33	89	5	6000	1	70,00
10207005 001	CGS-345P	Piccolo	Zinc	66,5	100	33	89	5	3000	1	35,00
10207007 001	CGS-345P	Piccolo	Zinc	66,5	100	33	89	5	6000	1	70,00
10207505	CGi-345P	Piccolo	Inox	66,5	100	33	89	5	3000	1	35,00
10207507	CGi-345P	Piccolo	Inox	66,5	100	33	89	5	6000	1	70,00

Categoria commerciale: 1R

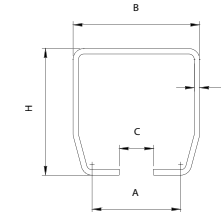

CGS-346P

Incontro inferiore a fissare
Bottom end cup to be fixed
Butée inférieure à fixer
Unteraufлагeschuh zum Aufschrauben
Encuentro inferior para fijar
Прикрепляемый нижний упор



CODE	ART.	Size	A	B	C	D	E	F	G	H	I	S	Box info	
													Pcs per pack	Kg
10705505 001	CGS-346P	Piccolo	119	112	30	11	84	154	33	112	50	4	2	3,6
10706005	CGi-346P	Piccolo	119	112	30	11	84	154	33	112	50	4	2	3,6

Finishing: Zincato / Galvanized

Finishing: Inox / Stainless steel

Categoria commerciale: 1T

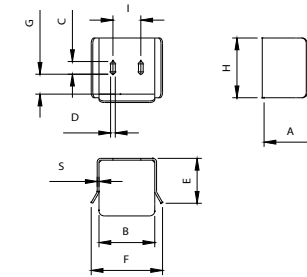

CGS-347P

Ruota terminale per monorotaia
End wheel for monorail
Galet d'extrémité pour rail
Endrad für Einfachschiene
Rueda terminal para monocaril
Концевое колесо монорельса



CODE	ART.	Size	A	B	C	D	E	F	G	H	L	M	N	S	Box info	
															Pcs per pack	Kg
10705005 001	CGS-347P	Piccolo	141	100	104	Ø78	129	12	15	89	66	37	20	4	2	3,4
10705305	CGi-347P	Piccolo	141	100	104	Ø78	129	12	15	89	66	37	20	4	2	3,4

Finishing: Zincato / Galvanized

Finishing: Inox / Stainless steel

Categoria commerciale: 1T

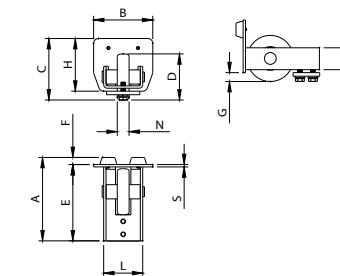

CGS-350.8 Grande

Carrello auto-portante 8 ruote per cancelli a sbalzo
8 wheels cantilever carriage for gates
Chariot autoportant 8 roues pour portails
8-rädriger Laufwagen für freitragende Tore
Carro autoportante 8 ruedas para puertas correderas
Самонесущая тележка 8 колес для откидных ворот



CARATTERISTICHE

- Corpo monoblocco che assicura resistenza alla struttura
- Indicato per i climi più umidi in quanto evita la corrosione del carrello
- I cuscinetti di nuova generazione schermati e silenziosi proteggono i carrelli dalla polvere; adatti a temperature che vanno dai -30° ai +80°.
- Autobilanciato
- 8 ruote di supporto per ogni carrello
- Allineamento longitudinale su 16 ruote
- Perno centrale di rotazione

FEATURES

- Monoblock body that ensure strenght to the structure
- Suitable to the humid climate to avoid the carriage corrosion
- Noiseless bearings of new generation shielded to protect against dust suitable for temperatures from -30 ° C to + 80 ° C
- Self-balancing
- 8 support wheels for each carriage
- Longitudinal alignment on 16 wheels
- Central rotation pin

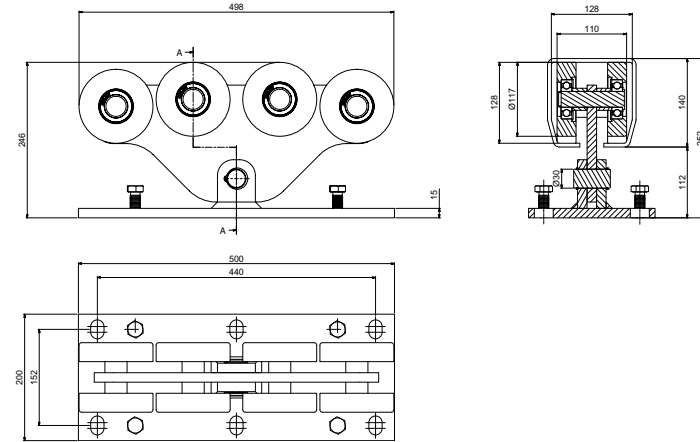

CODE	ART.	Size	Box info	
			Pcs per pack	Kg
10130011 001	CGS-350.8 G	Grande	1	44,0

Finishing: Zincato / Galvanized

Categoria commerciale: 10

Dimensioni minime getto cemento armato
Minimum dimensions of the reinforced concrete casting
Dimensions minimums du coulage du ciment armé
Mindestgröße des Stahlbetonguss
Dimensiones mínimas colada cemento armado
Минимальные размеры железобетонной стяжки

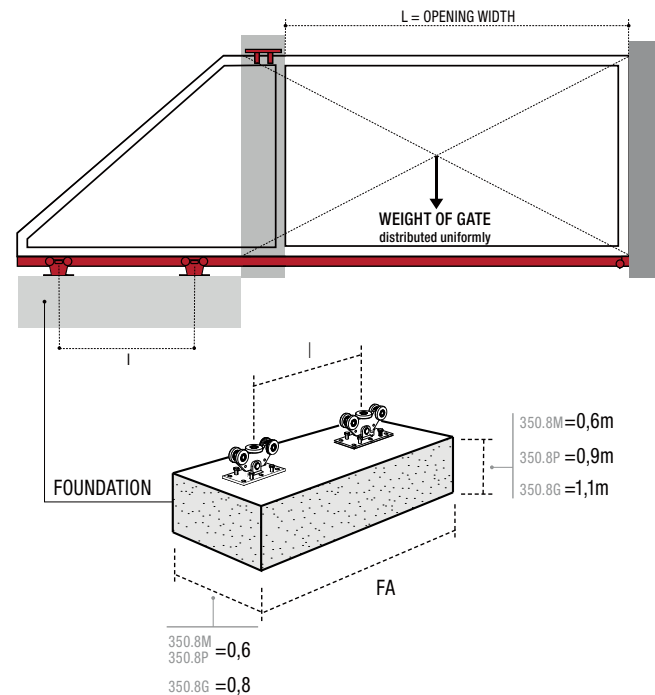

CGS 350.8 Grande (F1max=4000 Kg)										
Weight (Kg)	L=8 m		L=10 m		L=12 m		L=14 m		L=16 m	
	FA (M)	I (M)	FA (M)	I (M)	FA (M)	I (M)	FA (M)	I (M)	FA (M)	I (M)
800	2,40	1,50	2,80	1,90	3,30	2,40	3,80	2,90	4,40	3,50
850	2,50	1,60	2,90	2,00	3,40	2,50	4,00	3,10	4,60	3,70
900	2,60	1,70	3,10	2,20	3,60	2,70	4,20	3,30	4,90	4,00
950	2,70	1,80	3,20	2,30	3,80	2,90	4,40	3,50	5,10	4,20
1000	2,80	1,90	3,30	2,50	4,00	3,10	4,60	3,70	5,30	4,40
1050	2,90	2,00	3,50	2,60	4,10	3,20	4,80	3,90	5,60	4,70
1100	3,00	2,10	3,70	2,80	4,30	3,40	5,10	4,20	5,90	5,00
1150	3,20	2,30	3,80	2,90	4,50	3,60	5,30	4,40	6,20	5,30
1200	3,30	2,40	4,00	3,10	4,70	3,80	5,60	4,70	6,50	5,60

CGS-345G

Monorotaia per cancelli auto-portanti
Monorail for cantilever gates
Rais pour portails autoportants
Einfachschiene für selbsttragende Tore
Monocaril para puertas autoportantes
Монорельс для самонесущих ворот

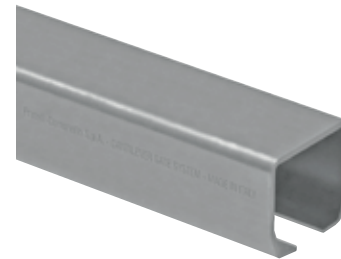

CODE	ART.	Size	Finishing	A	B	C	H	S	L	Box info	
										Pcs per pack	Kg
10207020	CGS-345G	Grande	Raw	98	140	38	140	6	3000	1	67,0
10207022	CGS-345G	Grande	Raw	98	140	38	140	6	6000	1	134,0
10207020 001	CGS-345G	Grande	Zinc	98	140	38	140	6	3000	1	67,0
10207022 001	CGS-345G	Grande	Zinc	98	140	38	140	6	6000	1	134,0

Categoria commerciale: 1R

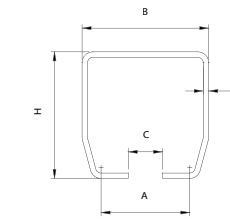

CGS-346G

Incontro inferiore a fissare
Bottom end cup to be fixed
Butée inférieure à fixer
Unteraufлагes Schuh zum Aufschrauben
Encuentro inferior para fijar
Прикрепляемый нижний упор



CODE	ART.	Size	A	B	C	D	E	F	G	H	I	S	Box info	
													Pcs per pack	Kg
10705510 001	CGS-346G	Grande	159	154	35	13	120	197	55	165	77	5	2	7,6

Finishing: Zincato / Galvanized

Categoria commerciale: 1T

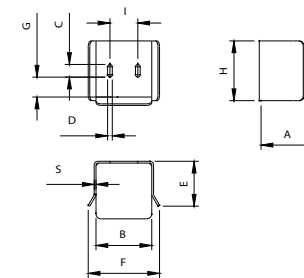

CGS-347G

Ruota terminale per monorotaia
End wheel for monorail
Galet d'extrémité pour rail
Endrad für Einfachschiene
Rueda terminal para monocaril
Концевое колесо монорельса



CODE	ART.	Size	A	B	C	D	E	F	G	H	L	M	N	S	Box info	
															Pcs per pack	Kg
10705010 001	CGS-347G	Grande	195	140	155	Ø98	170	24,5	15	140	95	56	30	5	2	8,3

Finishing: Zincato / Galvanized

Categoria commerciale: 1T

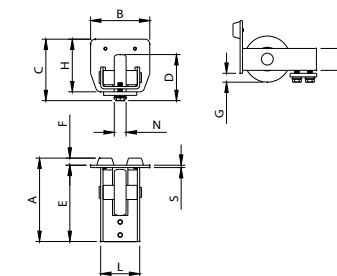

CGi-350.5 P

Carrello autoportante 5 ruote per cancelli a sbalzo

5 wheels cantilever carriage for gates
Chariot autoportant 5 roues pour portails
5-rädiger Laufwagen für freitragende Tore
Carro autoportante 5 ruedas para puertas correderas
Самонесущая тележка 5 колес для откидных ворот



CARATTERISTICHE

- Corpo monoblocco che assicura resistenza alla struttura
- Indicato per i climi più umidi in quanto evita la corrosione del carrello
- Cuscinetti silenziosi di nuova generazione schermati per una migliore protezione dalla polvere; adatti a temperature che vanno dai -30° ai +80°
- 4 ruote di supporto in acciaio Inox
- Rotella centrale di allineamento
- Perno centrale di rotazione

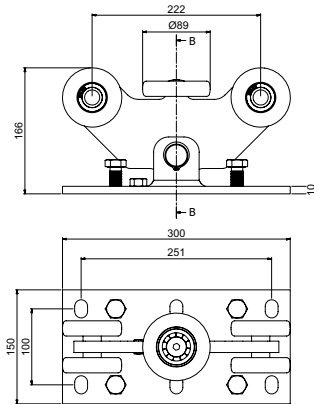

FEATURES

- Monoblock body that ensure strenght to the structure
- Suitable to the humid climate to avoid the carriage corrosion
- Noiseless bearings of new generation shielded to protect against dust suitable for temperatures from -30 ° C to + 80 ° C
- 4 support stainless steel wheels
- Alignment central wheel
- Central rotation pin

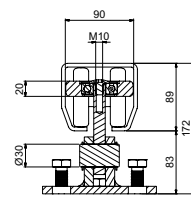

CODE	ART.	Size	Box info	
			Pcs per pack	Kg
10130305	CGi-350.5 P	Piccolo	1	11,0

Finishing: Inox / Stainless steel

Categoria commerciale: 10

Dimensioni minime getto cemento armato
Minimum dimensions of the reinforced concrete casting
Dimensions minimums du coulage du ciment armé
Mindestgröße des Stahlbetonguss
Dimensiones mínimas colada cemento armado
Минимальные размеры железобетонной стяжки

CGi 350.5 P (F1max = 1000 Kg)										
Weight (Kg)	L=2,5 m		L=3 m		L=3,5 m		L=4 m		L=4,5 m	
	FA (m)	I (m)	FA (m)	I (m)	FA (m)	I (m)	FA (m)	I (m)	FA (m)	I (m)
250	1,70	1,00	2,00	1,30	2,30	1,60	2,70	2,00	3,10	2,40
275	1,80	1,10	2,20	1,50	2,50	1,80	2,90	2,20	3,30	2,60
300	2,00	1,30	2,30	1,60	2,70	2,00	3,20	2,50	3,60	3,00
325	2,10	1,40	2,50	1,80	3,00	2,30	3,50	2,80	4,00	3,30
350	2,30	1,60	2,70	2,00	3,20	2,50	3,80	3,10	4,40	3,70
375	2,50	1,80	3,00	2,30	3,50	2,80	4,10	3,40	4,80	4,10
400	2,70	2,00	3,20	2,50	3,80	3,10	4,50	3,80	5,20	4,60

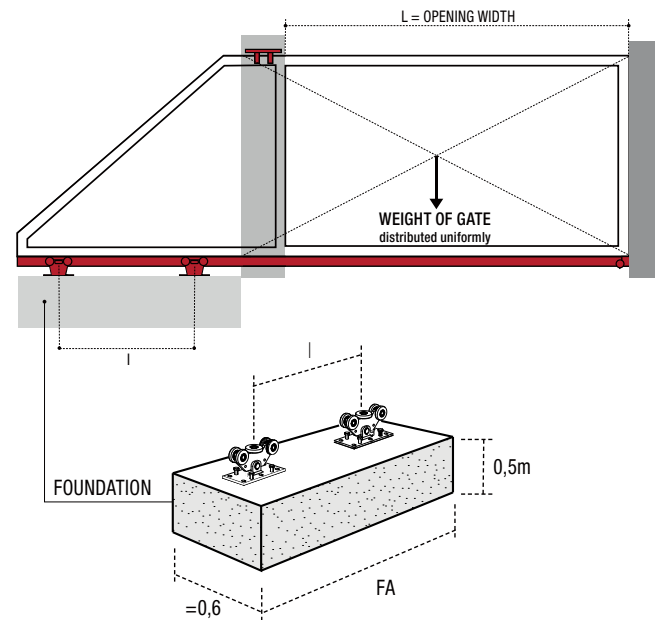

CGi-345P

Monorotaia in acciaio inox per cancelli auto-portanti

Monorail in stainless steel for cantilever gates
Rail en aluminium extrudé pour portails autoportants
Einfachschiene aus fließgepresstem Aluminium für selbsttragende Tore
Monocaril de acero inoxidable para puertas autoportantes
Монорельс из нержавеющей стали для ворот из нержавеющей стали



CODE	ART.	Size	A	B	C	H	S	L	Box info	
									Pcs per pack	Kg
10207505	CGi-345P	Piccolo	66,5	100	33	89	5	3000	1	35,00
10207507	CGi-345P	Piccolo	66,5	100	33	89	5	6000	1	70,00

Finishing: Inox / Stainless steel

Categoria commerciale: 2R

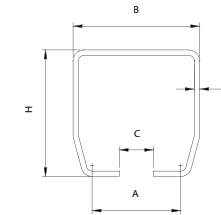

CGi-346

Incontro inferiore a fissare

Bottom end cup to be fixed
Butée inférieure à fixer
Unterauftrageschuh zum Aufschrauben
Encuentro inferior para fijar
Прикрепляемый нижний упор



CODE	ART.	Size	A	B	C	D	E	F	G	H	I	S	Box info	
													Pcs per pack	Kg
10706005	CGi-346P	Piccolo	119	112	30	11	84	154	33	112	50	4	2	3,6

Finishing: Inox / Stainless steel

Categoria commerciale: 2T

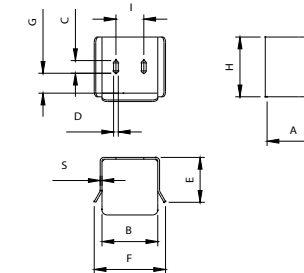

CGi-347

Ruota terminale per monorotaia

End wheel for monorail
Galet d'extrémité pour rail
Endrad für Einfachschiene
Rueda terminal para monocaril
Концевое колесо монорельса



CODE	ART.	Size	A	B	C	D	E	F	G	H	L	M	N	S	Box info	
															Pcs per pack	Kg
10705305	CGi-347P	Piccolo	141	100	104	Ø78	129	12	15	89	66	37	20	4	2	3,4

Finishing: Inox / Stainless steel

Categoria commerciale: 2T

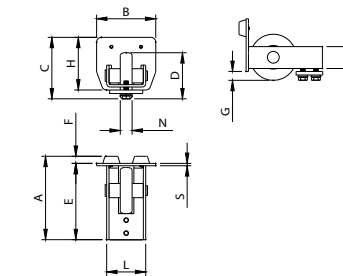



CG-05

Contro piastra per carrelli piccolo e grande
Counter plate for carriages - small and large
Contre-plaque pour chariots - petit e grand
Gegenplatte für Laufwagen gross und klein
Contraplaca para carros pequeño y grande
Контрплита для больших и малых тележек

CODE	ART.	Size	A	B	C	D	E	F	S	Box info	
										Pcs per pack	Kg
10131005 001	CG-05P	Piccolo	300	150	125,5	100	24	17	4	2	2,70
10131010 001	CG-05G	Grande	500	200	220	152	30	21	4	2	6,00
10131305	CGi-05P	Piccolo	300	150	125,5	100	24	17	4	2	2,70

Finishing: Zincato / Galvanized
Finishing: Inox / Stainless steel

Categoria commerciale: 1T

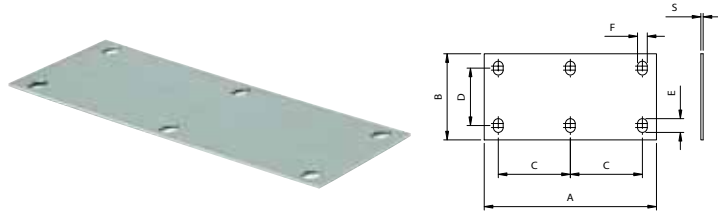

CG-348

Ancorante filettato per carrelli
CGS 350 e CGS 350.8
Threaded tie rods for carriages CGS 350 and CGS 350.8
Tirant fileté pour chariots CGS 350 et CGS 350.8
Gewindestange für Laufwagen CGS 350 und CGS 350.8
Anclaje roscado para carros CGS 350 y CGS 350.8
Резьбовое анкерное крепление для тележек CGS 350 и CGS 350.8



CODE	ART.	Size	A	B	C	L	M	Box info	
								Pcs per pack	Kg
10130505 001	CG-348	M16	300	85	60	380	M16	12	8,40
10130510 001	CG-348	M20	300	85	70	385	M20	12	13,10
10130705	CGi-348	M16	300	85	60	380	M16	12	8,40

Finishing: Zincato / Galvanized
Finishing: Inox / Stainless steel

Categoria commerciale: 1T

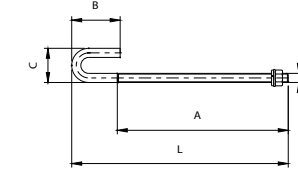

Mounting instructions art. CG-05

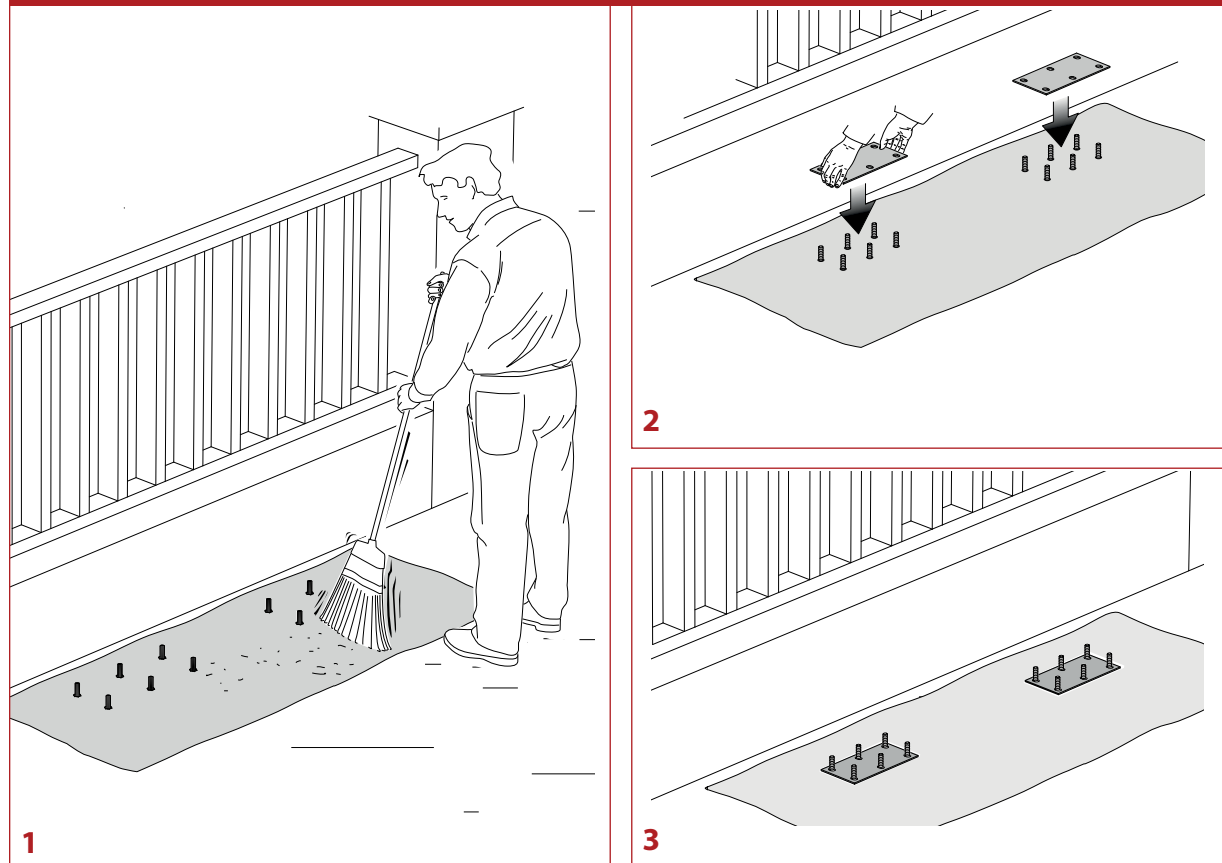

Mounting instructions art. CG-348

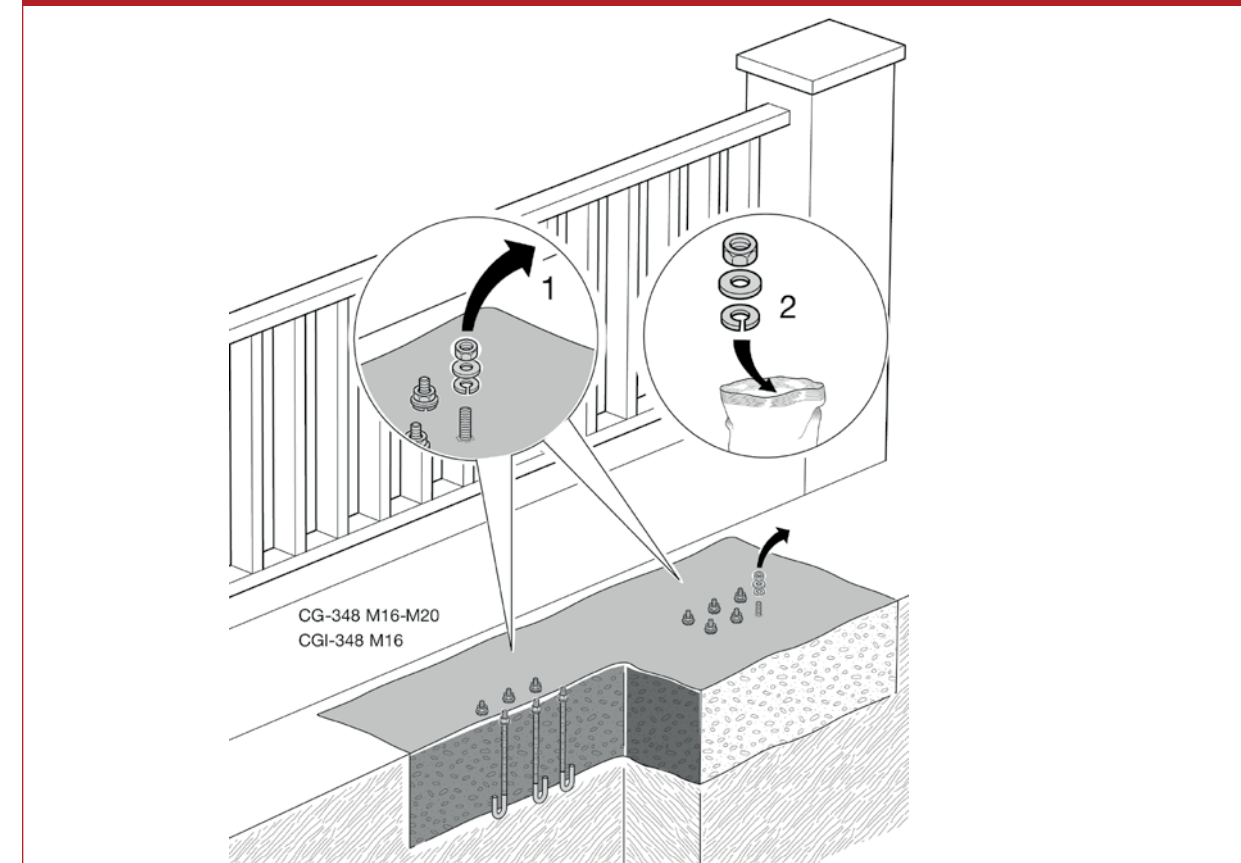



CG-10

Dima di allineamento ancoranti e fissaggio carrelli

Alignment tie rods template and fixture of the carriages
Calibre d'alignement des tirants et fixation chariots
Lehre für die Aufreihung der Gewindestangen und für die Laufwagenbefestigung
Plantilla de alineación anclajes y fijación carros
Шаблон выравнивания с анкерным креплением и креплением для тележек

CODE	ART.	R	Box info	
			Pcs per pack	Kg
10131100 001	CG-10	500 ÷ 5400	1	20,00

Finishing: Zincato / Galvanized

Categoria commerciale: 1T

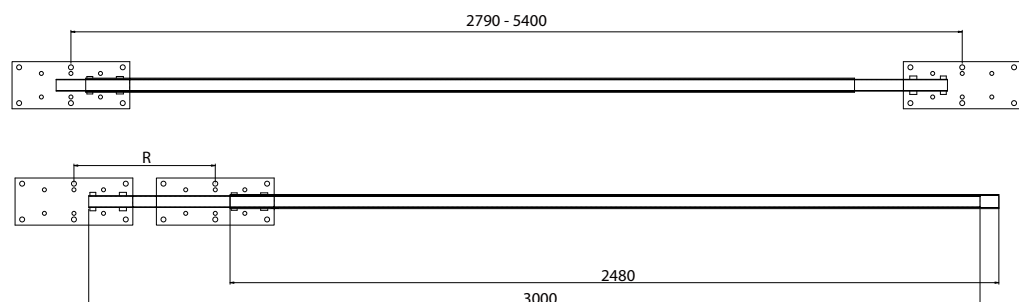
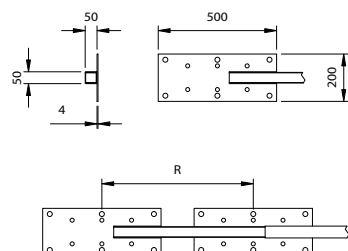

Mounting instructions art. CG-10

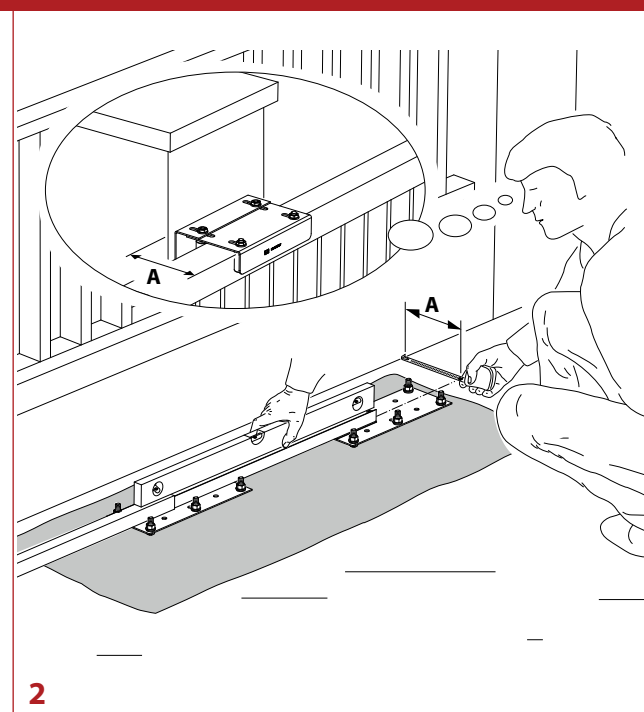
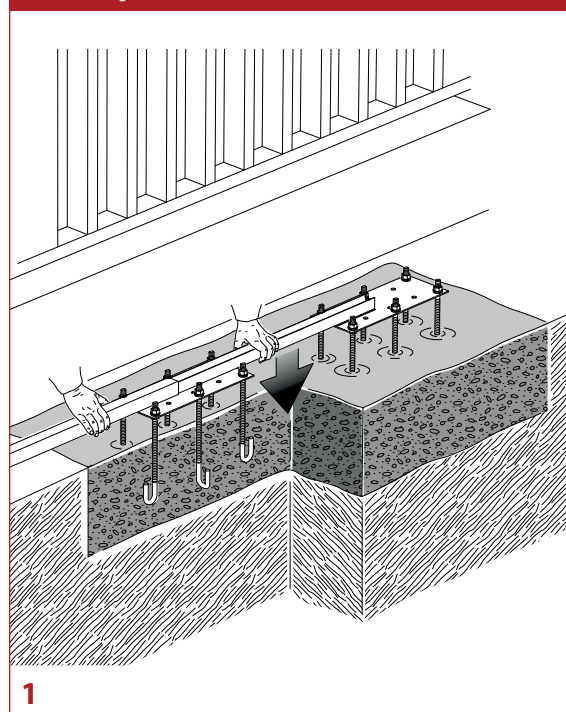

CG-10 / Info

Scheda di utilizzo dima CG-10

Sheet for the template installation CG-10

Schéma d'utilisation du calibre CG-10

CG-10 Lehre Verwendungskarte

Esquema de uso de la plantilla CG-10

Спецификация использования шаблона CG-10

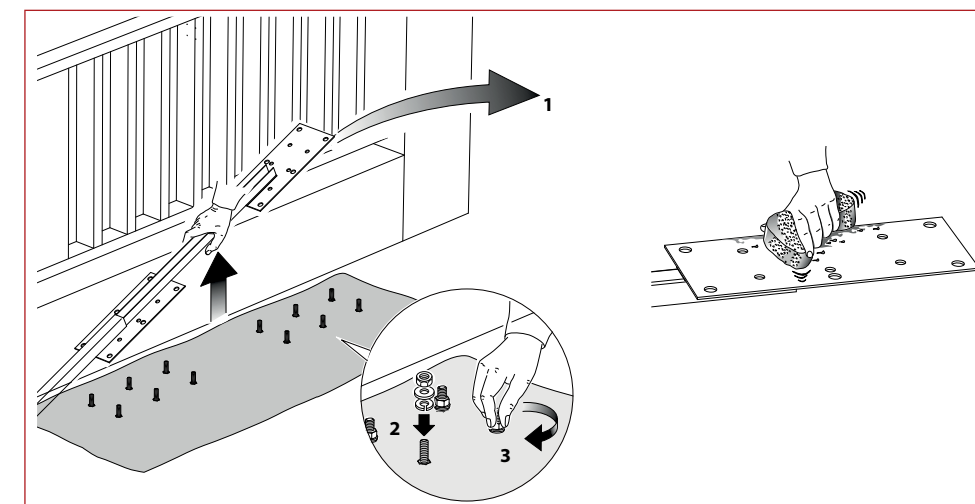
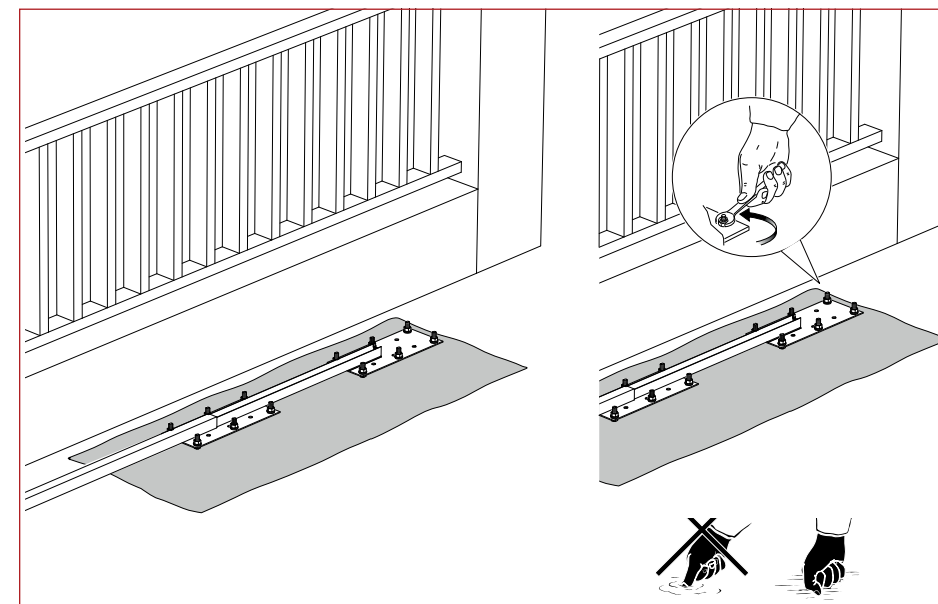
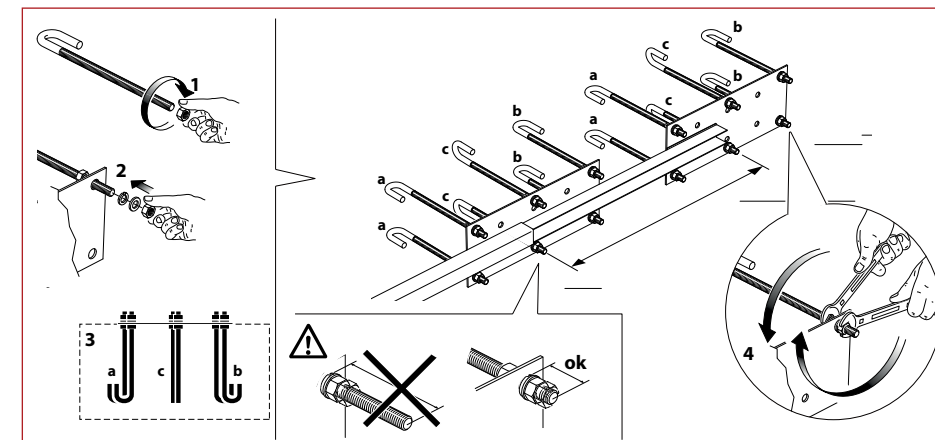



CGS-245

Monorotaia per cancelli auto-portanti
Monorail for cantilever gates
Rails pour portails autoportants
Einfachschiene für selbsttragende Tore
Monocarril para puertas autoportantes
Монорельс для самонесущих ворот

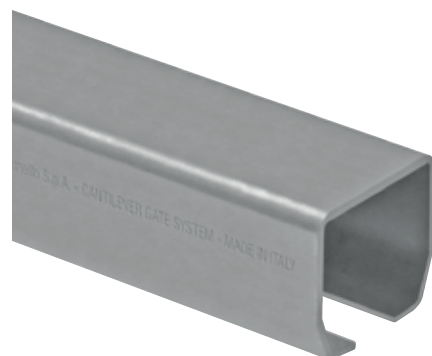

CODE	ART.	Size	Finishing	A	B	C	H	S	L	Box info	
										Pcs per pack	Kg
10207004	CGS-245M	Mini	Raw	48	68	23	68	3,5	3000	1	18,25
10207024	CGS-245M	Mini	Raw	48	68	23	68	3,5	6000	1	36,50
10207006	CGS-245P	Piccolo	Raw	66,5	100	33	89	5	3000	1	35,00
10207025	CGS-245P	Piccolo	Raw	66,5	100	33	89	5	6000	1	70,00
10207014	CGS-245G	Grande	Raw	98	140	38	140	6	3000	1	67,00
10207026	CGS-245G	Grande	Raw	98	140	38	140	6	6000	1	134,00
10207004 001	CGS-245M	Mini	Zinc	48	68	23	68	3,5	3000	1	18,25
10207024 001	CGS-245M	Mini	Zinc	48	68	23	68	3,5	6000	1	36,50
10207006 001	CGS-245P	Piccolo	Zinc	66,5	100	33	89	5	3000	1	35,00
10207025 001	CGS-245P	Piccolo	Zinc	66,5	100	33	89	5	6000	1	70,00
10207014 001	CGS-245G	Grande	Zinc	98	140	38	140	6	3000	1	67,00
10207026 001	CGS-245G	Grande	Zinc	98	140	38	140	6	6000	1	134,00
10207505	CGI-345P	Piccolo	Inox	66,5	100	33	89	5	3000	1	35,00
10207507	CGI-345P	Piccolo	Inox	66,5	100	33	89	5	6000	1	70,00

Categoria commerciale: 1R

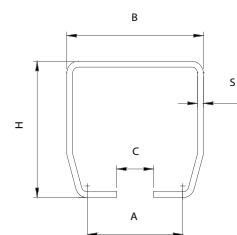

CGS-345

Monorotaia per cancelli auto-portanti
Monorail for cantilever gates
Rails pour portails autoportants
Einfachschiene für selbsttragende Tore
Monocarril para puertas autoportantes
Монорельс для самонесущих ворот

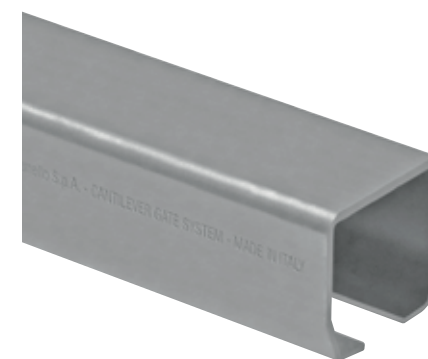

CODE	ART.	Size	Finishing	A	B	C	H	S	L	Box info	
										Pcs per pack	Kg
10207001	CGS-345M	Mini	Raw	48	68	23	68	3,5	3000	1	18,25
10207002	CGS-345M	Mini	Raw	48	68	23	68	3,5	6000	1	36,50
10207005	CGS-345P	Piccolo	Raw	66,5	100	33	89	5	3000	1	35,00
10207007	CGS-345P	Piccolo	Raw	66,5	100	33	89	5	6000	1	70,00
10207020	CGS-345G	Grande	Raw	98	140	38	140	6	3000	1	67,00
10207022	CGS-345G	Grande	Raw	98	140	38	140	6	6000	1	134,00
10207001 001	CGS-345M	Mini	Zinc	48	68	23	68	3,5	3000	1	18,25
10207002 001	CGS-345M	Mini	Zinc	48	68	23	68	3,5	6000	1	36,50
10207005 001	CGS-345P	Piccolo	Zinc	66,5	100	33	89	5	3000	1	35,00
10207007 001	CGS-345P	Piccolo	Zinc	66,5	100	33	89	5	6000	1	70,00
10207020 001	CGS-345G	Grande	Zinc	98	140	38	140	6	3000	1	67,00
10207022 001	CGS-345G	Grande	Zinc	98	140	38	140	6	6000	1	134,00
10207505	CGI-345P	Piccolo	Inox	66,5	100	33	89	5	3000	1	35,00
10207507	CGI-345P	Piccolo	Inox	66,5	100	33	89	5	6000	1	70,00

Categoria commerciale: 1R

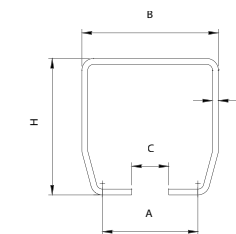

Mounting instructions art. CGS-245

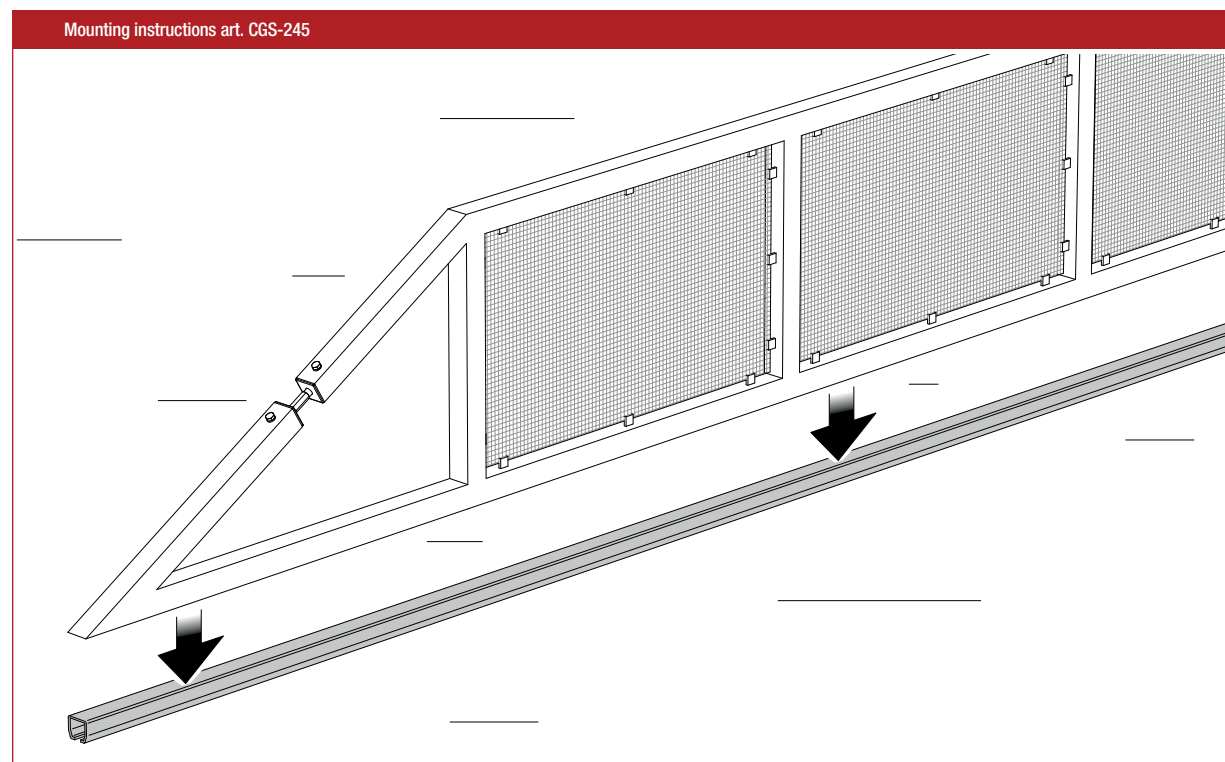

Mounting instructions art. CGS-345

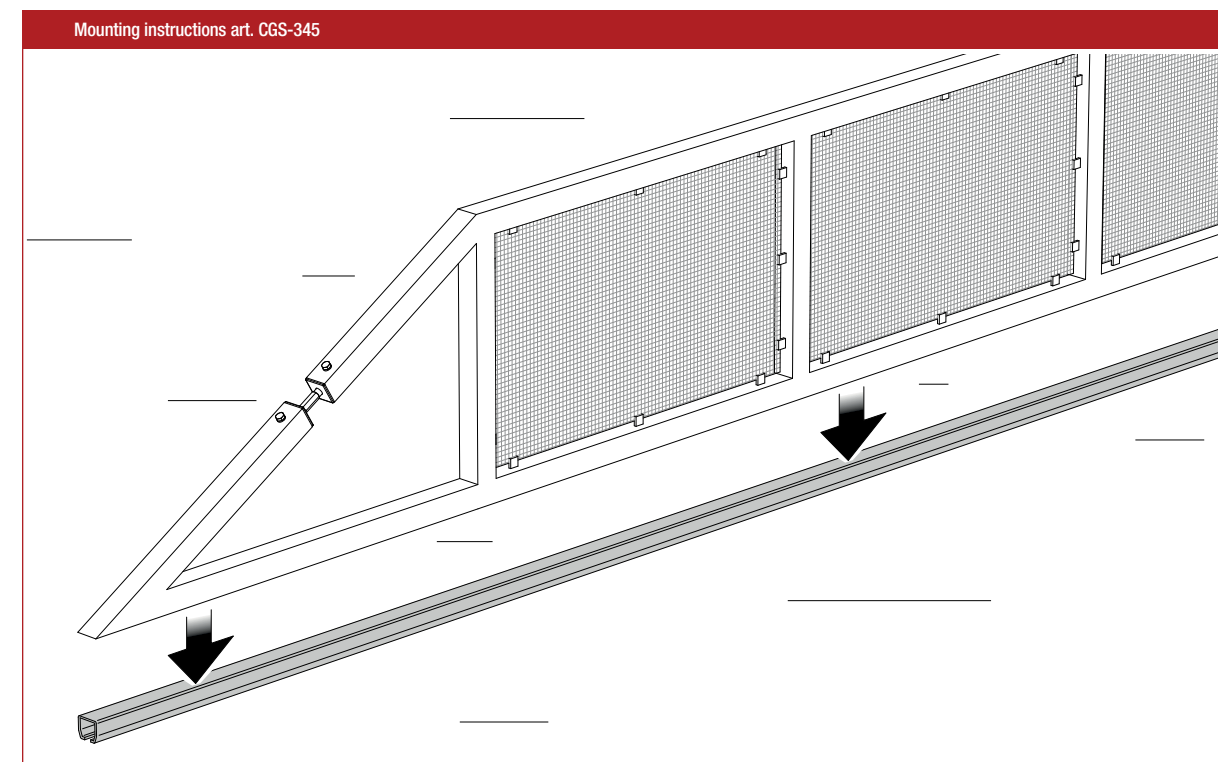



CGA-345

Monorotaia in alluminio estruso per cancelli auto portanti

Monorail in extruded aluminium for cantilever gates
Rail en aluminium extrudé pour portails autoportants
Einfachschiene aus fließgepresstem Aluminium für selbsttragende Tore
Monocarril de aluminio extruido para puertas autoportantes
Монорельс из экструдированного алюминия для самонесущих ворот



CODE	ART.	Size	Finishing	A	B	C	H	L	Box info	
									Pcs per pack	Kg
10208001	CGA-345M	Mini	Raw	61	83	23	79	3000	1	12,00
10208003	CGA-345M	Mini	Raw	61	83	23	79	6000	1	24,00
10208005	CGA-345P	Piccolo	Raw	80,5	106,5	30	102,5	3000	1	16,00
10208007	CGA-345P	Piccolo	Raw	80,5	106,5	30	102,5	6000	1	32,00
10208009	CGA-345G	Grande	Raw	128	168	38	164	3000	1	50,30
10208011	CGA-345G	Grande	Raw	128	168	38	164	6000	1	100,65

Finishing: Alluminio / Aluminium

Categoria commerciale: 1R

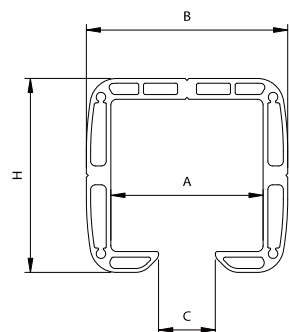

CGS-346

Incontro inferiore a fissare

Bottom end cup to be fixed
Butée inférieure à fixer
Unterauflegesoh zum Aufschrauben
Encuentro inferior para fijar
Приклепняемый нижний упор



CODE	ART.	A	B	C	D	E	F	G	H	I	S	Box info	
												Pcs per pack	Kg
10705501 001	CGS-346M	104	78	25	9	75	114	25	91	38	4	2	2,30
10705505 001	CGS-346P	119	112	30	11	84	154	33	112	50	4	2	3,60
10705510 001	CGS-346G	159	154	35	13	120	197	55	165	77	5	2	7,60

Finishing: Zincato / Galvanized

10706005 CGI-346P

Finishing: Inox / Stainless steel

Categoria commerciale: 1T

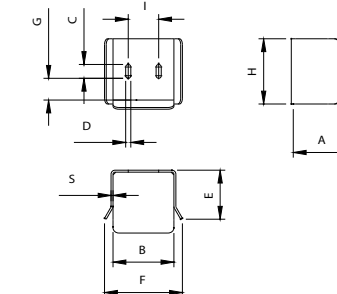

Mounting instructions art. CGA-345

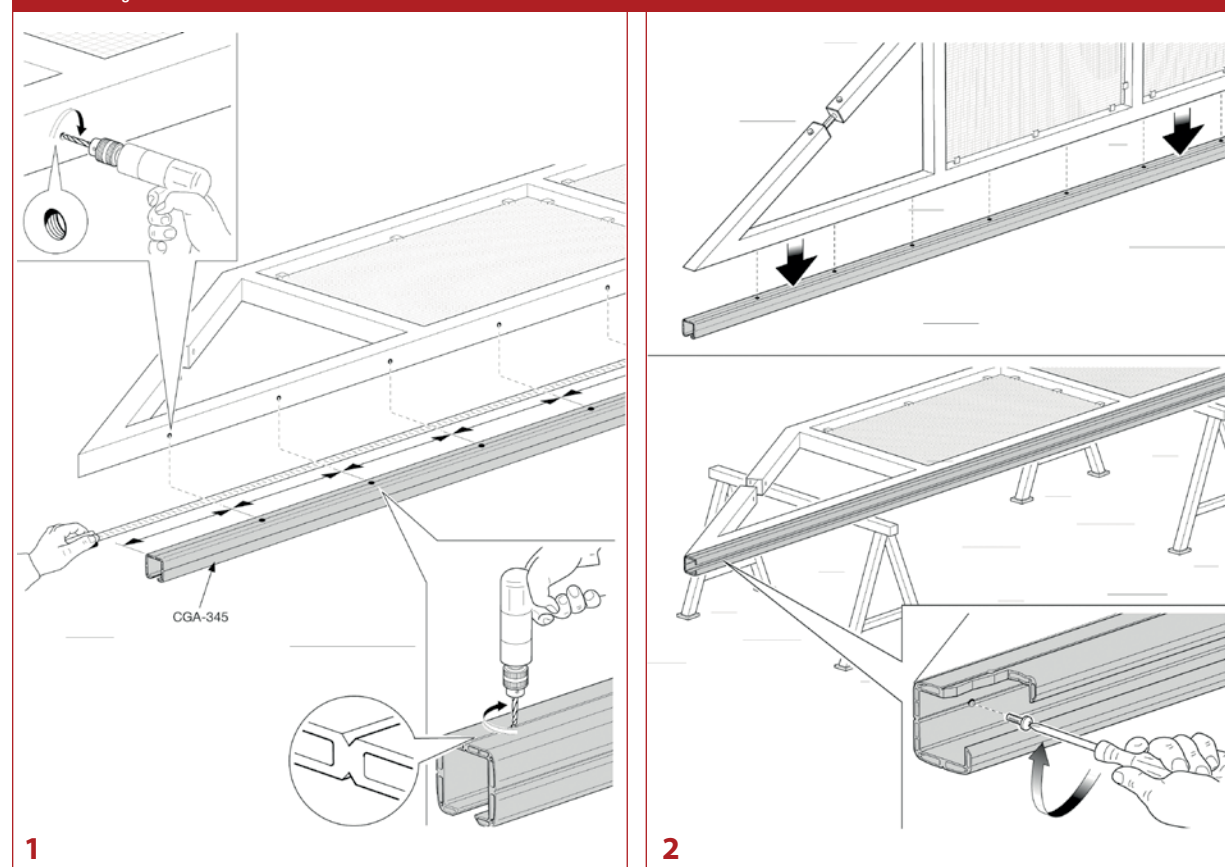

Mounting instructions art. CGS-346

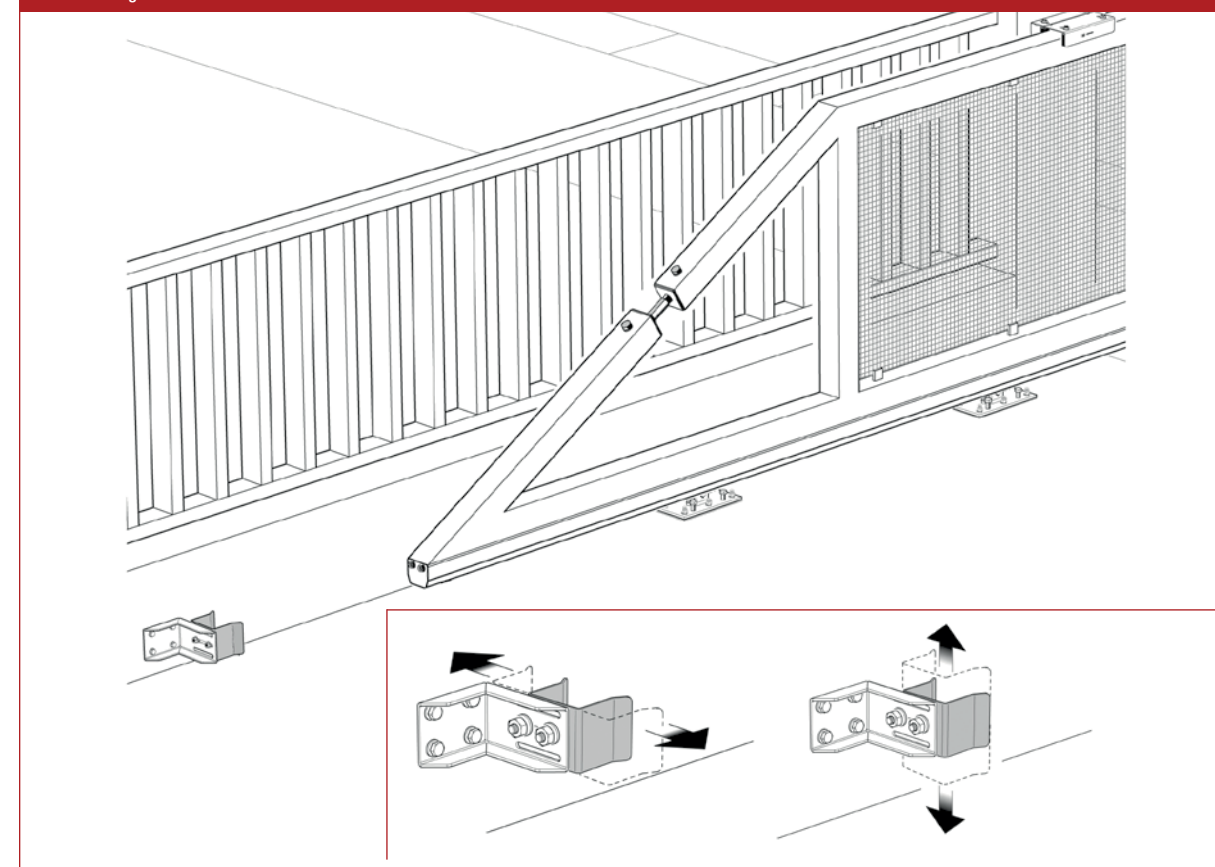



CGS-347

Ruota terminale per monorotaia
End wheel for monorail
Galet d'extrémité pour rail
Endrad für Einfachschiene
Rueda terminal para monocarril
Концевое колесо монорельса

CODE	ART.	A	B	C	D	E	F	G	H	L	M	N	S	Box info	
														Pcs per pack	Kg
10705001 001	CGS-347M	135	68	82,5	Ø 68	123	12	14,5	68	45	32	15	4	2	2,00
10705005 001	CGS-347P	141	100	104	Ø 78	129	12	15	89	66	37	20	4	2	3,40
10705010 001	CGS-347G	195	140	155	Ø 98	170	24,5	15	140	95	56	30	5	2	8,30
Finishing: Zincato / Galvanized															
10705305	CGI-347P	141	100	104	Ø 78	129	12	15	89	66	37	20	4	2	3,40
Finishing: Inox / Stainless steel															

Categoria commerciale: 1T

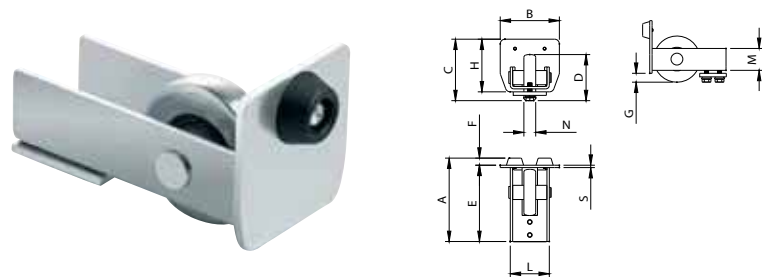

CGA-347

Ruota terminale in nylon per monorotaia in alluminio
Nylon end wheel for aluminium monorail
Galet d'extrémité en nylon pour rail en aluminium
Nylon-Endrolle für Einfachschiene aus Aluminium
Rueda terminal de nylon para monocarril de aluminio
Концевое колесо из нейлона для алюминиевого монорельса

CODE	ART.	A	B	C	D	E	F	G	H	L	M	N	Box info	
													Pcs per pack	Kg
10705200 001	CGA-347M	119	83	83	Ø 66	119	16	7	79	45	32	15	2	2,10
10705205 001	CGA-347P	140	106,5	118	Ø 79	125	15	9,6	102,5	66	37	26	2	3,40
10705210 001	CGA-347G	185	168	170	Ø 117	185	24,5	11,5	164	95	56	30	2	8,30

Finishing: Alluminio / Aluminium

Categoria commerciale: 1T

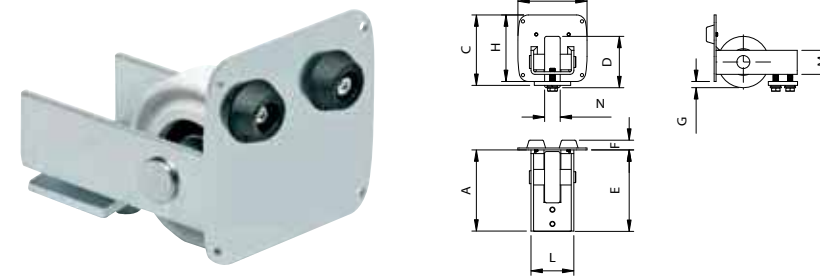

Mounting instructions art. CGS-347

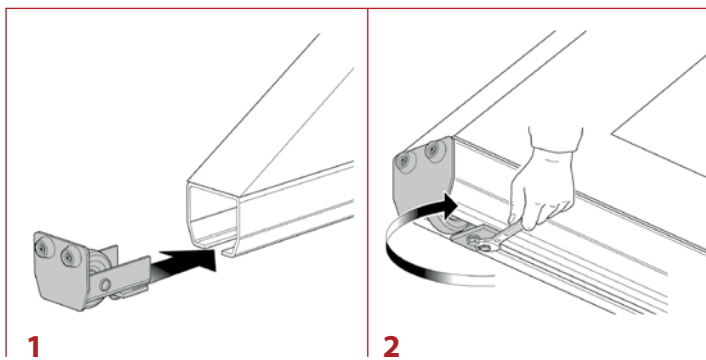
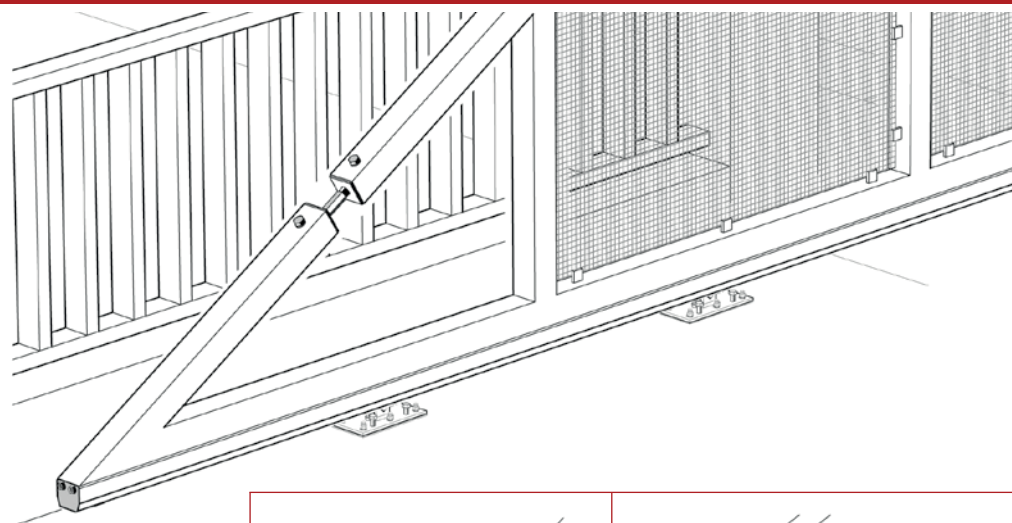

Mounting instructions art. CGA-347

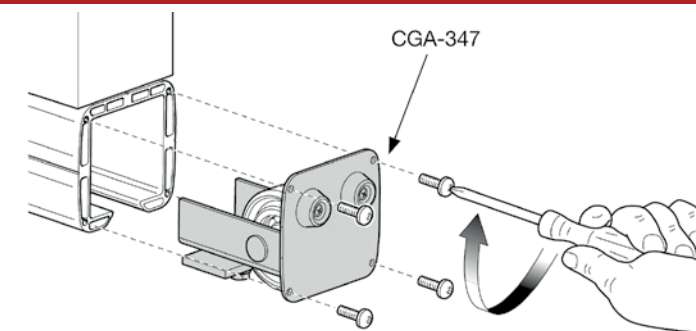

1

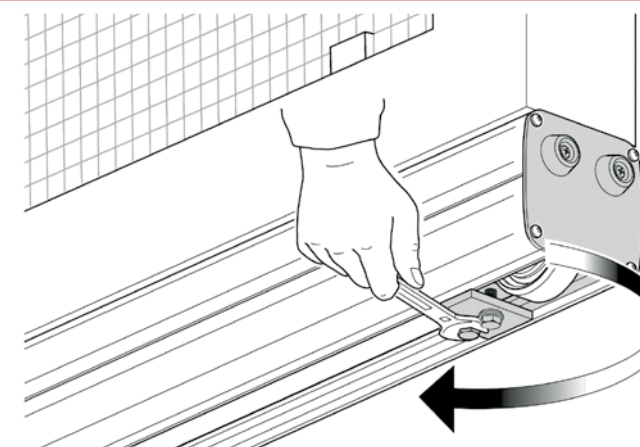

2



CG-35

Supporto intermedio di sostegno con rullo in nylon

Intermediate support with nylon roller
Support intermédiaire de soutien avec rouleau en nylon
Mittlerer Stütze für selbsttragende Tore
Soporte intermedio de sostén con rodillo de nylon
Промежуточная опора с нейлоновым роликом



CODE	ART.	A	B	D	F	H	I	S	Box info	
									Pcs per pack	Kg
10707705 001	CG-35P	122	80	Ø 60	17	95	70	5	1	1,40
10707710 001	CG-35G	161	100	Ø 80	21	120	90	6	1	3,10

Finishing: Zincato / Galvanized

Categoria commerciale: 1T

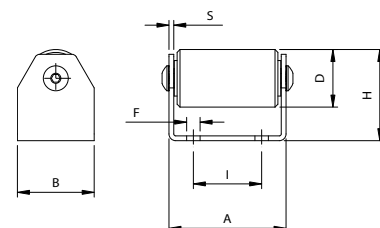

CG-15

Staffa angolare regolabile fissaggio a muro per incontro

Adjustable wall mounting angle racket for end cup
Platine angulaire réglable fixation au mur pour butée
Verstellbare Eckmuerhalterung für Aullageschuh
Placa angular regulable fijación a la pared para encuentro
Угловой регулируемый кронштейн крепления к стене для упора



CODE	ART.	A	B	C	D	E	F	H	I	S	Box info	
											Pcs per pack	Kg
10708001 001	CG-15M	155	110	65	Ø 9,5	9	78	165	64	5	1	2,60
10708005 001	CG-15P	155	110	80	Ø 9,5	11	90	190	64	5	1	2,90
10708010 001	CG-15G	155	120	82	Ø 13	13	117	220	70	5	1	3,30

Finishing: Zincato / Galvanized

Categoria commerciale: 1T

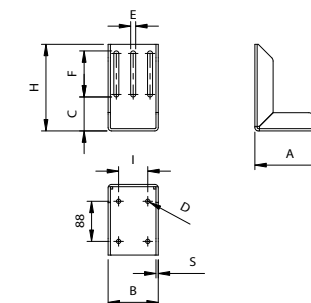

Mounting instructions art. CG-35

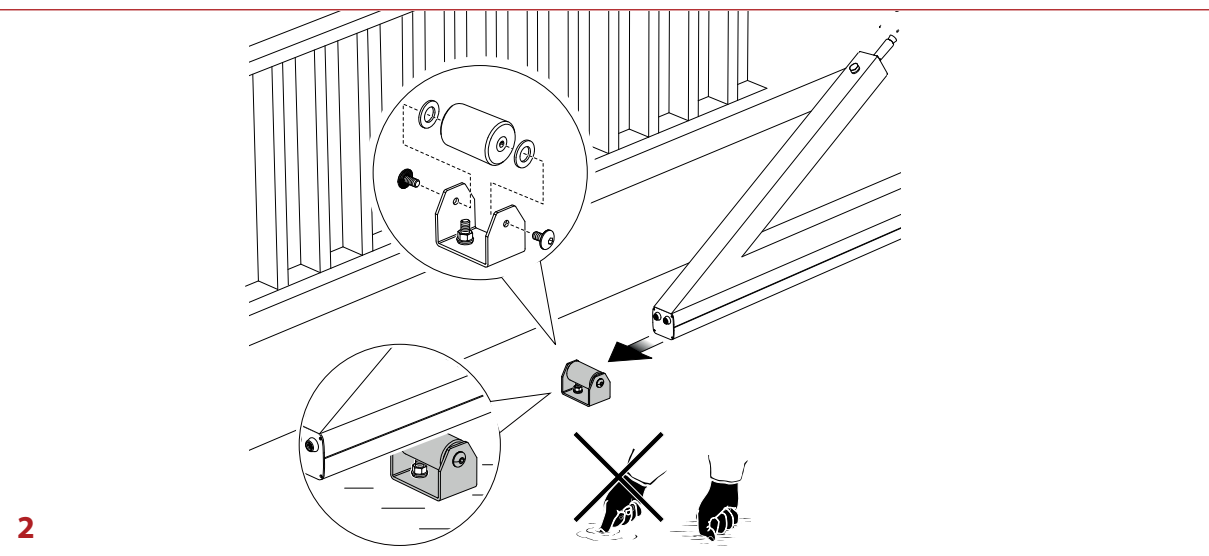
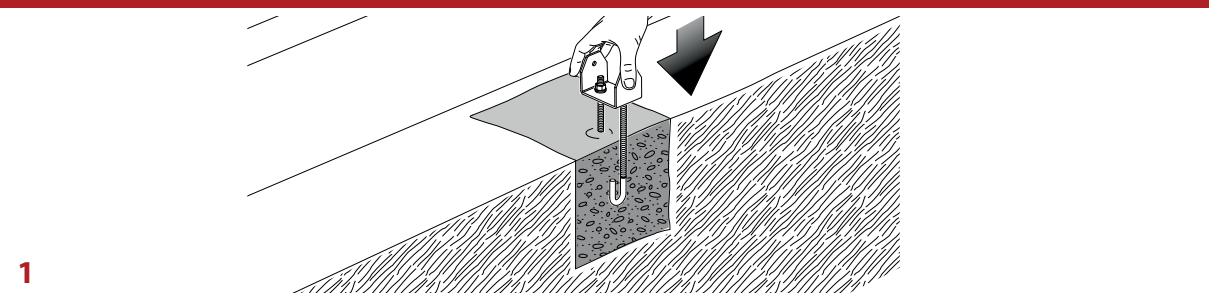

Mounting instructions art. CG-15

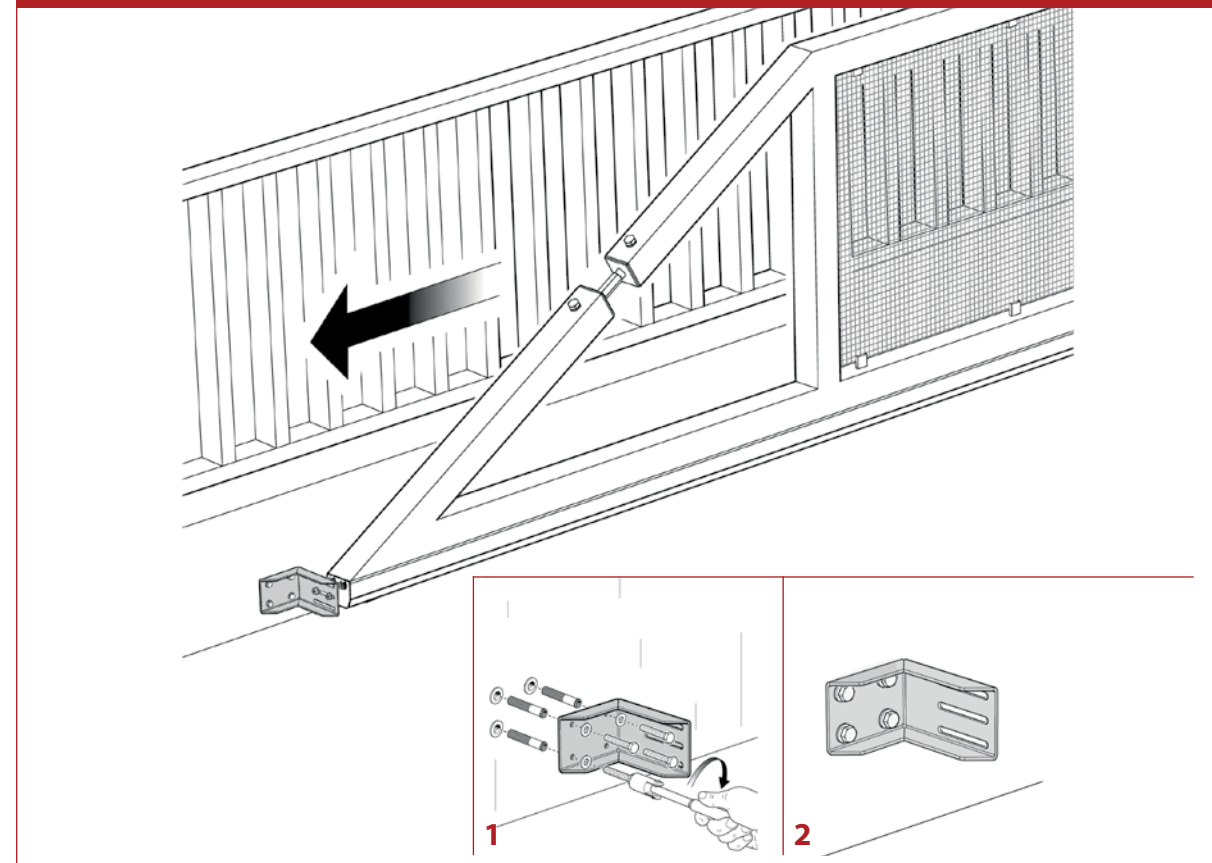



CG-20

Terminale senza ruota per monorotaia
End stopper without wheel for monorail
Embout d'extrémité sans galet pour rail
Endpfropfen für Einfachschiene ohne Rad
Terminal sin rueda para monocarril
Наконечник без колеса для монорельса

CODE	ART.	Size	A	B	C	E	F	H	S	Box info	
										Pcs per pack	Kg
10707101 001	CG-20M	Mini	68	68	78	155	12	68	4	2	1,20
10707105 001	CG-20P	Piccolo	100	100	105	155	12	89	4	2	1,80
10707110 001	CG-20G	Grande	140	140	155	165	24,5	140	5	2	3,90

Finishing: Zincato / Galvanized

Categoria commerciale: 1T



ART. CG-20M / CG-20P



ART. CG-20G

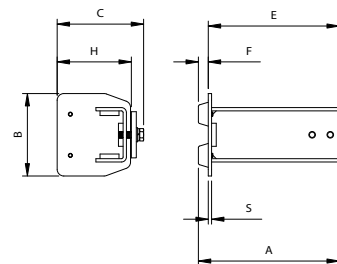

CGA-20

Terminale per monorotaia in alluminio
End stopper for aluminium monorail
Embout d'extrémité pour rail en aluminium
Endpfropfen für Einfachschiene aus Aluminium
Terminal para monocarril de aluminio
Наконечник для алюминиевого монорельса

CODE	ART.	Size	A	B	F	H	Box info	
							Pcs per pack	Kg
10707001 001	CGA-20M	Mini	16	83	12	79	2	0,44
10707005 001	CGA-20P	Piccolo	15	106,5	12	102,5	2	0,60
10707010 001	CGA-20G	Grande	29,5	168	24,5	164	2	2,20

Finishing: Alluminio / Aluminium

Categoria commerciale: 1T

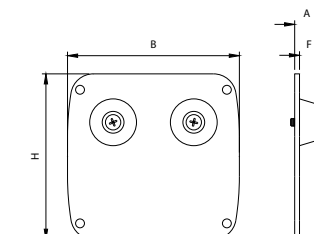

Mounting instructions art. CG-20

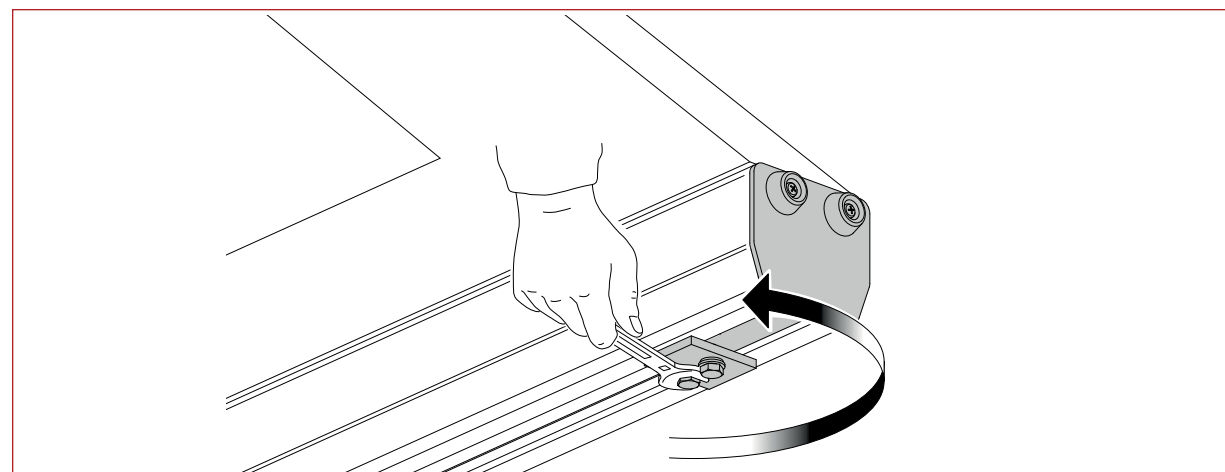
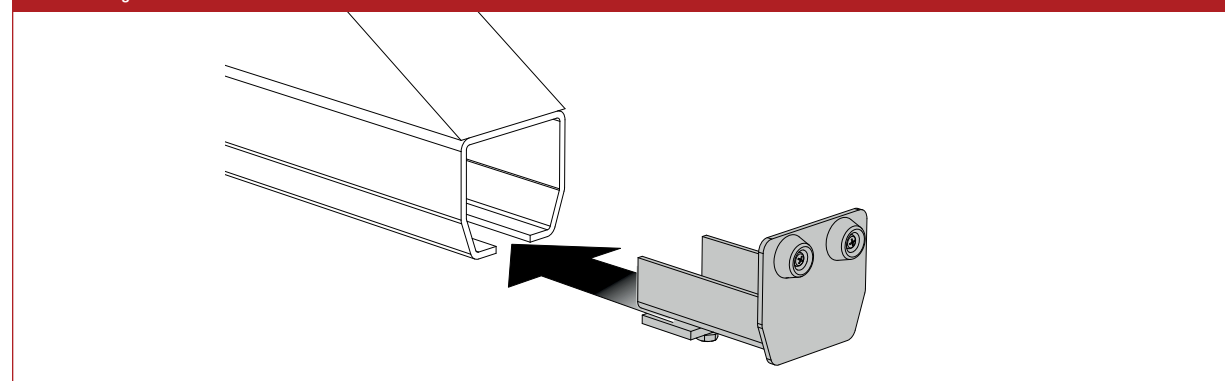

Mounting instructions art. CGA-20

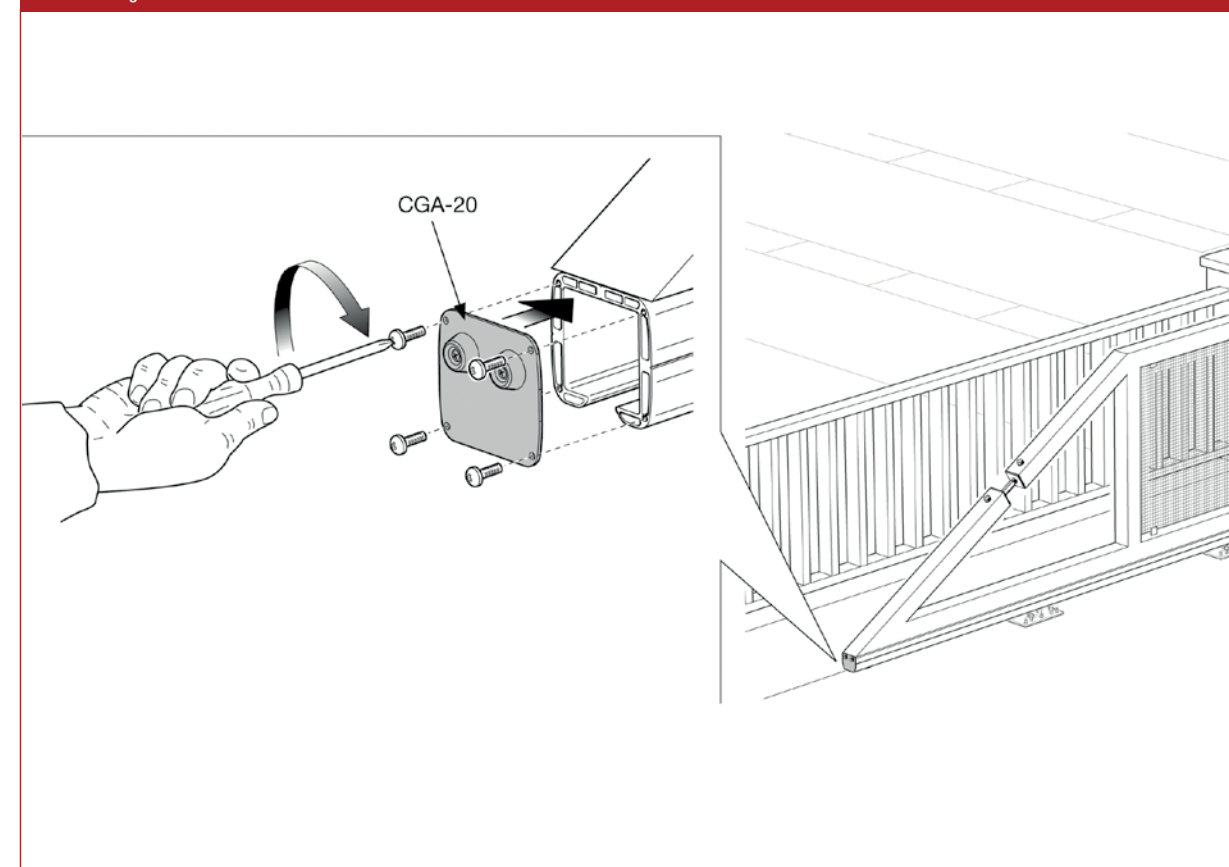



CG-25

Incontro inferiore con rullo in nylon
Lower end cup with nylon roller
Butée inférieure avec rouleau en nylon
Unteraufgeschuh mit Nylonrolle
Encuentro inferior con rodillo de nylon
Нижний упор с нейлоновый роликом

CODE	ART.	Size	A	B	D	F	H	I	S	Box info	
										Pcs per pack	Kg
10707501 001	CG-25M	Mini	80	40	∅ 50	8,5	115	45	5	2	1,30
10707505 001	CG-25P	Piccolo	122	50	∅ 60	11	130	75	5	2	2,60
10707510 001	CG-25G	Grande	161	60	∅ 80	13	140	90	6	2	5,00

Finishing: Zincato / Galvanized Categoria commerciale: 1T

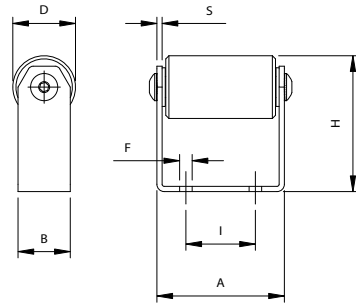

CG-30

Incontro per cancelli regolabile a fissare
Adjustable end cup to be fixed for gates
Butée réglable à fixer pour portails
Verstellbarer Aufgeschuh zum Aufschrauben für Tore
Encuentro para puertas regulable para fijar
Прикрепляемый упор для ворот регулируемый

CODE	ART.	Size	R	Box info	
				Pcs per pack	Kg
10707601 001	CG-30M	Mini	53-76	1	1,50
10707605 001	CG-30P	Piccolo	86-114	1	1,90
10707610 001	CG-30G	Grande	103-150	1	2,30

Finishing: Zincato / Galvanized Categoria commerciale: 1S

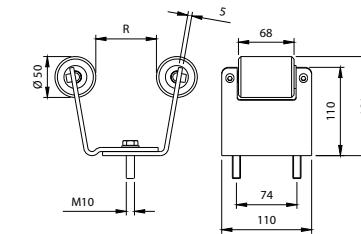

Mounting instructions art. CG-25

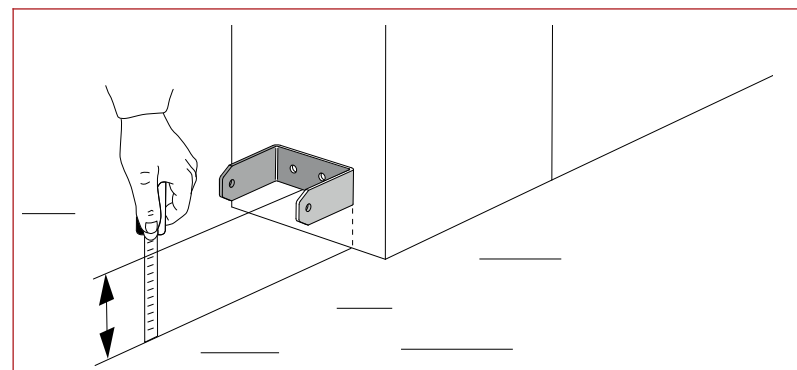
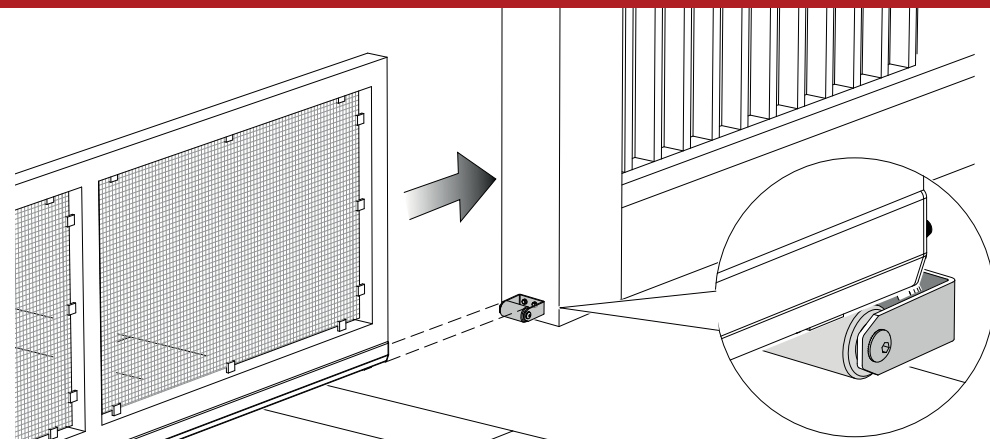

Mounting instructions art. CG-30

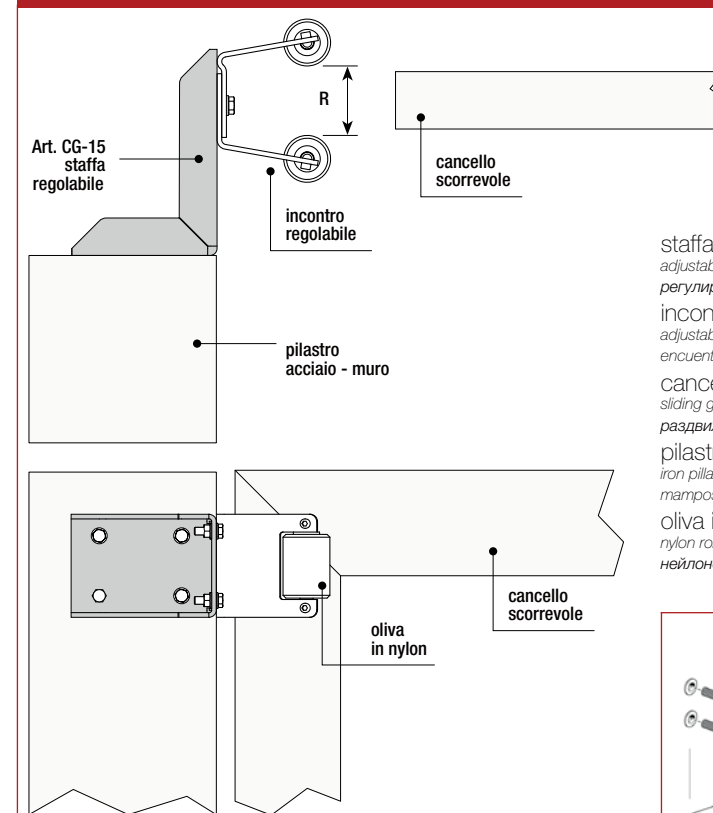

staffa regolabile
adjustable bracket / fixation réglable / verstellbarer träger / placa regulable / регулируемый кронштейн
incontro regolabile
adjustable end cup / butée réglable / Verstellbarer Aufgeschuh / encuentro regulable / регулируемый упор
cancello scorrevole
sliding gate / grille coulissante / Gleitend Tor / puerta corredera / раздвижные ворота
pilastro acciaio-muro
iron pillar - wall / pilier d'acier - mur / Säule Stahl - Wand / pilar acero-mampostería / стойка из стали - стена
oliva in nylon
nylon roller / rouleau en nylon / Nylon-Führungsrolle / rodillo de nylon / нейлоновый наконечник

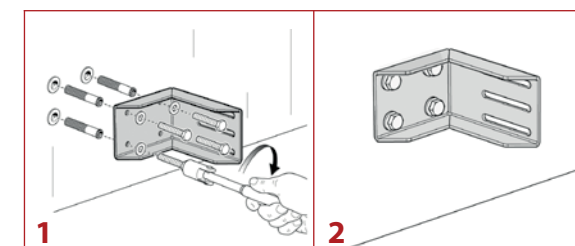



CG-40

Tirante in acciaio zincato per regolazioni cancelli
Tension bar for gate regulation
Tirants pour réglage portails
Ankerbolzen zur Torregulierung
Tensores de acero galvanizado para regulaciones puertas
Тяга из оцинкованной стали для регулирования ворот

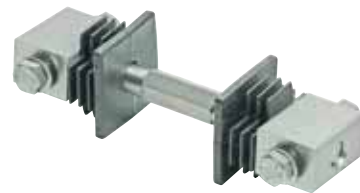

CODE	ART.	R		Box info	
				Pcs per pack	Kg
10131400 001	CG-40	50-100	19	2	1,30

Finishing: Zincato / Galvanized
 Categoria commerciale: 1T

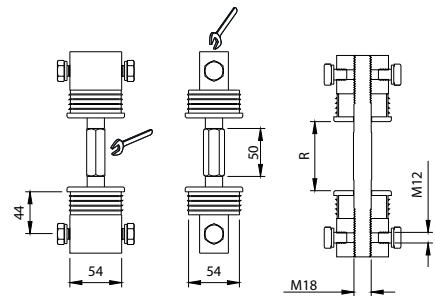

CG-251

Piastra guida cancello regolabile con ala lunga a fissare
Adjustable gate guide plate to be fixed with long wing
Plaque guide portail réglable à fixer avec aile longue
Verstellbare Torführungsplatte mit langem Flügel zum Aufschrauben
Placa de guía de la puerta regulable con ala larga para fijar
Пластина регулируемая направляющая ворот с длинной приклепываемой полкой

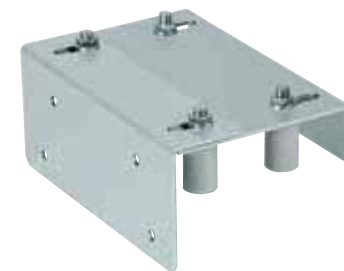

CODE	ART.	A	C	D	G	H	I	L	M	R	Box info	
											Pcs per pack	Kg
11310005 001	CG-251	74	58	Ø40	190	154	230	350	44-88	70-110	1	6,70
11310305	CGi-251	74	58	Ø40	190	154	230	350	44-88	70-110	1	6,70

Finishing: Zincato / Galvanized
 Finishing: Inox / Stainless steel
 Categoria commerciale: 1S

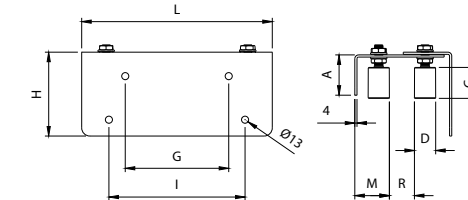

Mounting instructions art. CG-40

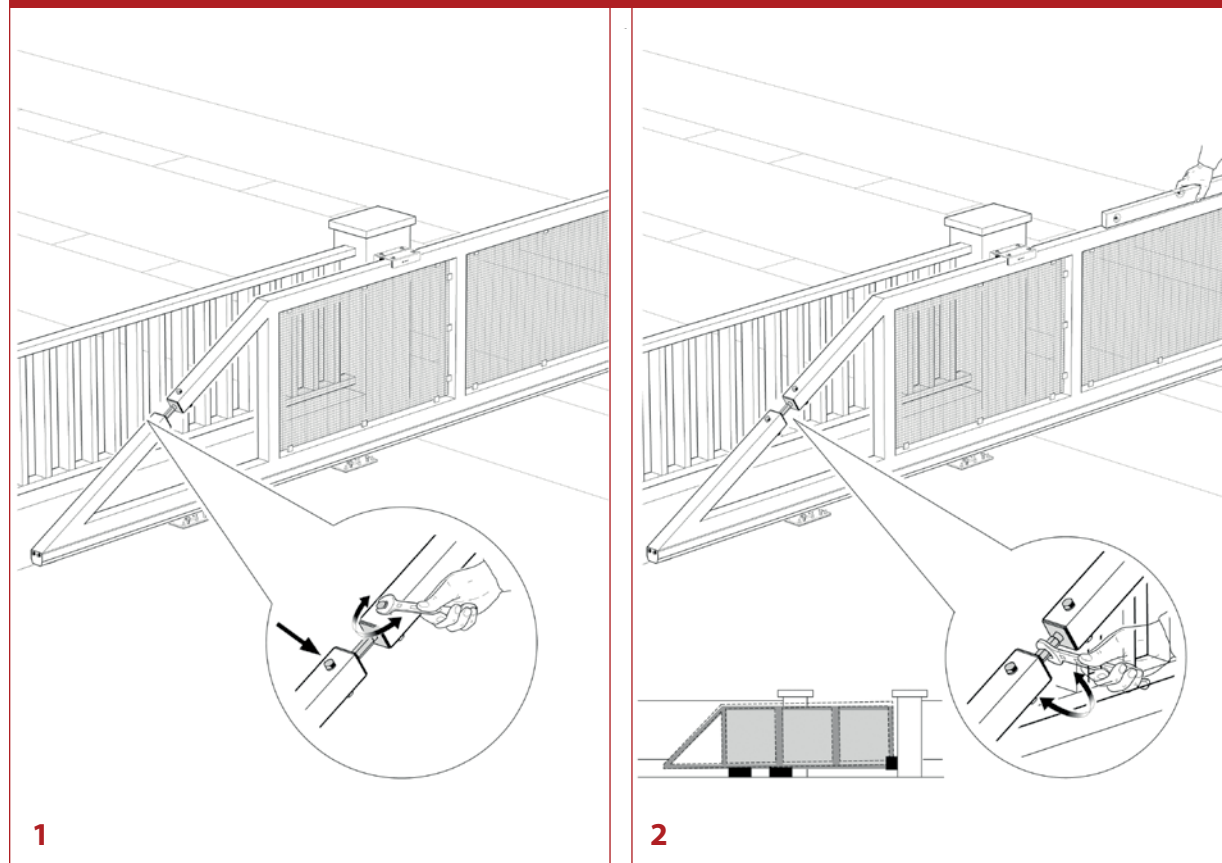

Mounting instructions art. CG-251

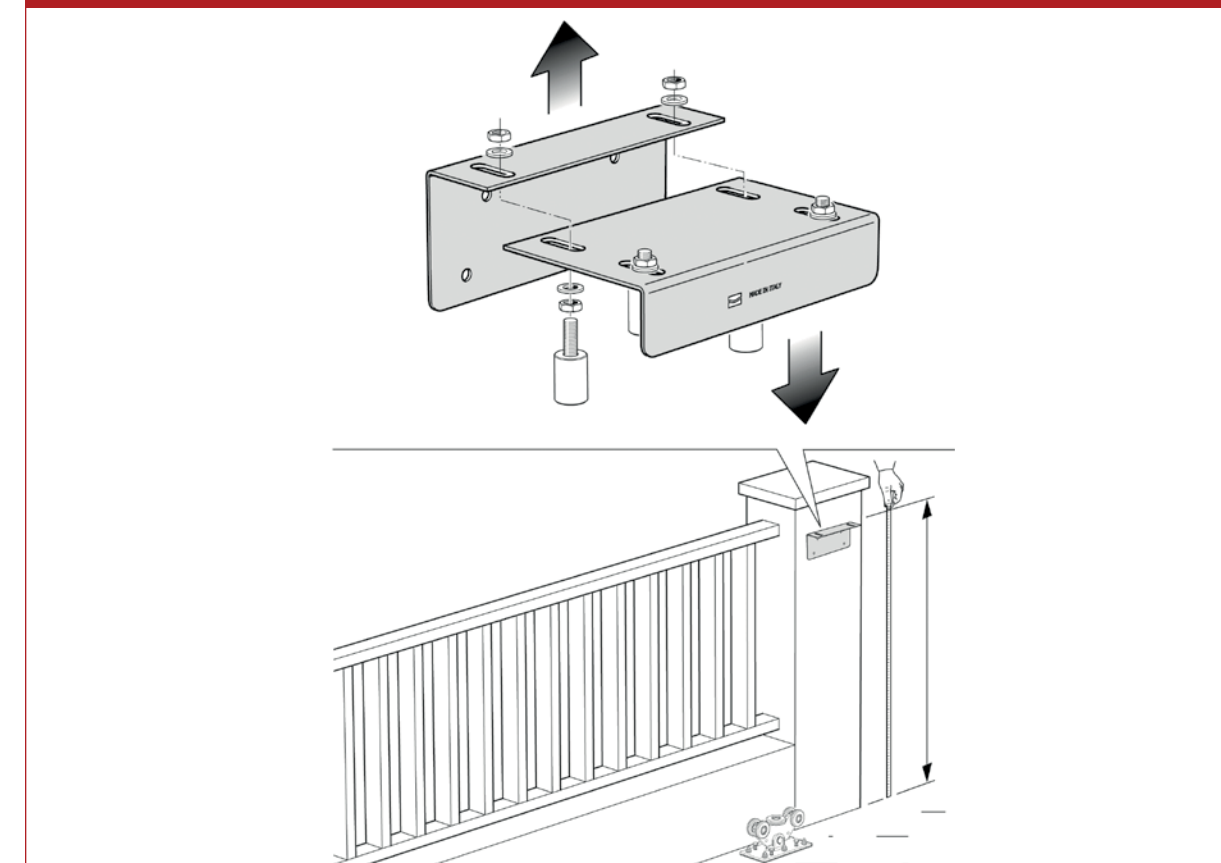



CG-252

Supporto anti deragliamento regolabile per art. CG-254

Adjustable support against derailment for art. CG-254
Support réglable anti-déraillement pour art. CG-254
Verstellbares Lager gegen Entgleisung für CG-254
Soporte anti-desarrilamiento regulable para art. CG-254
Опора для защиты от схода с рельсов регулируемая для art. CG-254



CODE	ART.	A	B	C	D	E	H	I	L	M	Box info	
											Pcs per pack	Kg
11310100 001	CG-252	55-85	109	57	Ø40	46	167	53	16	M12	2	1,60

Finishing: Zincato / Galvanized

Categoria commerciale: 1S

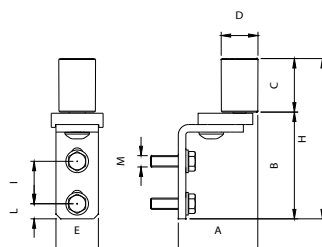

CG-254

Canalina a "U" per supporto anti deragliamento

U channel for supports against derailment
Caniveau à U pour supports anti-déraillement
Gegen Entgleisung U-Einfachschiene
Perfil en "U" para soporte anti-desarrilamiento
Желоб в форме "U" для опоры защиты от схода с рельсов

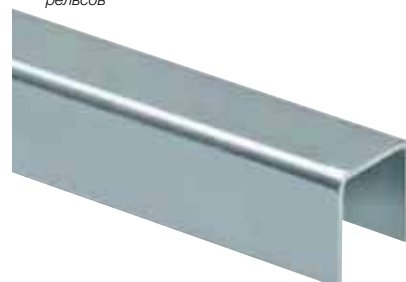

CODE	ART.	A	B	H	L	S	Box info	
							Pcs per pack	Kg
10210150 001	CG-254	50	42	50	3000	4	1	13,00

Finishing: Zincato / Galvanized

Categoria commerciale: 1S

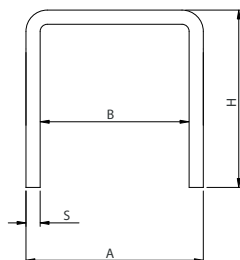

CG-256

Rullo in gomma guida cancello

Rubber roller for guiding gate
Rouleau en caoutchouc guide-portail
Torführungsrolle aus Schwarz Gummi
Rodillo de goma de guía de la puerta
Резиновый ролик направляющей ворот



CODE	ART.	A	Box info	
			Pcs per pack	Kg
11310300 001	CG-256	40	2	0,8
11310301 001	CG-256	50	2	1,7

Finishing: Zincato / Galvanized

Categoria commerciale: 1S

260

Cremaiglieria quadra

Square rack
Crémaillère carrée
Viereckige Zahnstange
Cremaiglieria cuadrada
Зубчатая рейка квадратная



CODE	ART.	Size	A	Module	Box info	
					Pcs per pack	Kg
11400505 001	260-22x22	L=1000	22	4	1	3,10
11400510 001	260-22x22	L=2000	22	4	1	6,20
11400515 001	260-30x30	L=1000	30	6	1	6,00

Finishing: Zincato / Galvanized

260-30x30: Modulo 6 / Module 6

Finishing: Inox / Stainless steel

Categoria commerciale: 1F

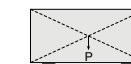
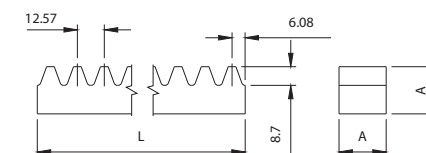

Peso uniformemente distribuito
Equally distributed weight

Mounting instructions art. 260

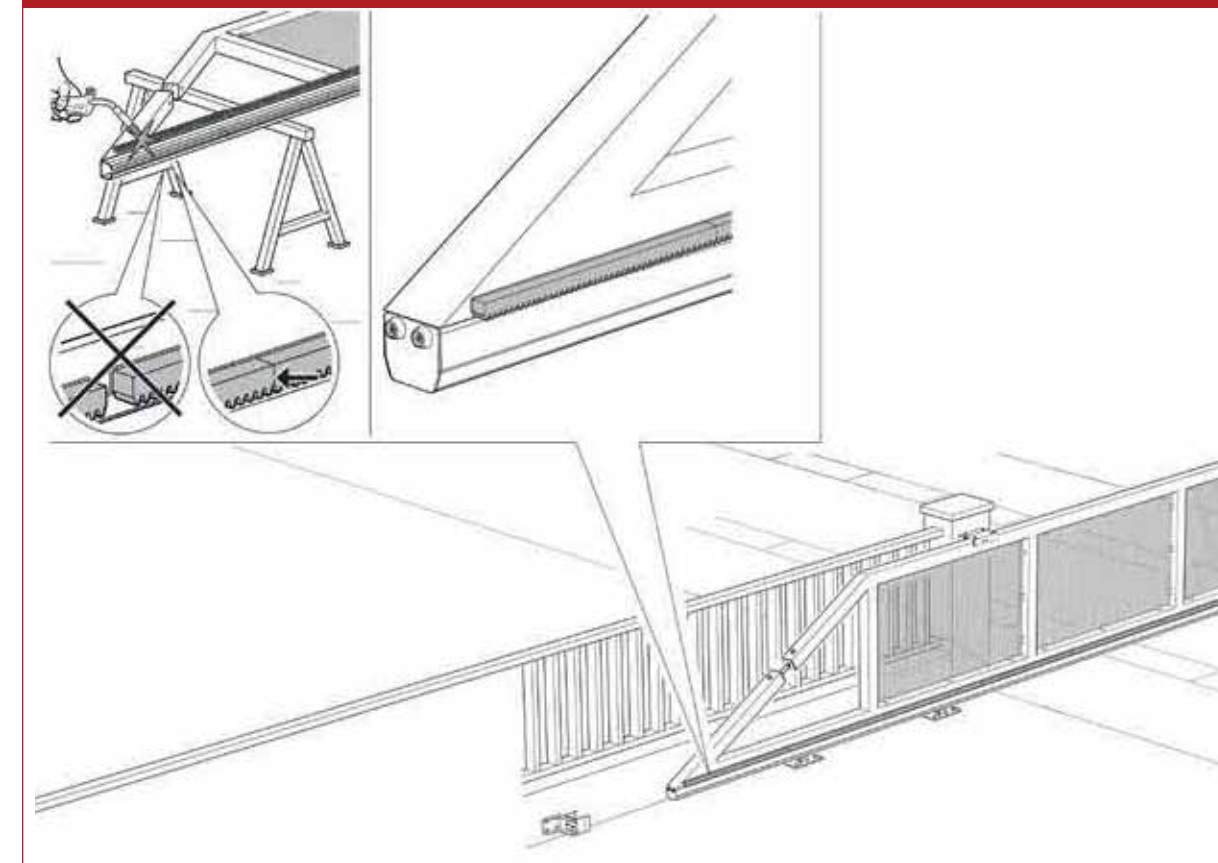



Cancelli autoportanti

Cantilever gate systems

262

Cremagliera Rettangolare
30x8 - 30x12 con fori
Rectangular rack 30x8-30x12 with holes
Crémaillère rectangulaire 30x8-30x12 avec trous
Rechteckige Zahnstange 30x8-30x12 mit Bohrungen
Cremaliera Rectangular 30x8 - 30x12 con agujeros
Зубчатая рейка прямоугольная 30x8 - 30x12 с отверстиями

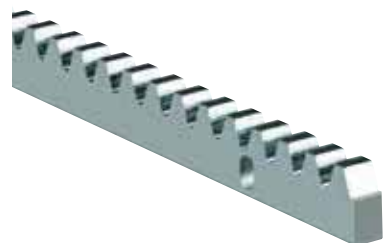

CODE	ART.	Size	L	Box info	
				Pcs per pack	Kg
11401205 001	262-30x8	L=1000	1000	1	1,60
11401005 001	262-30x12	L=1000	1000	1	2,40
11401010 001	262-30x12	L=2000	2000	1	4,90
Finishing: Zincato / Galvanized				Categoria commerciale: 1F	
11401105	262i-30x12	L=1000	1000	1	2,40
Finishing: Inox / Stainless steel				Categoria commerciale: 2F	

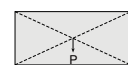
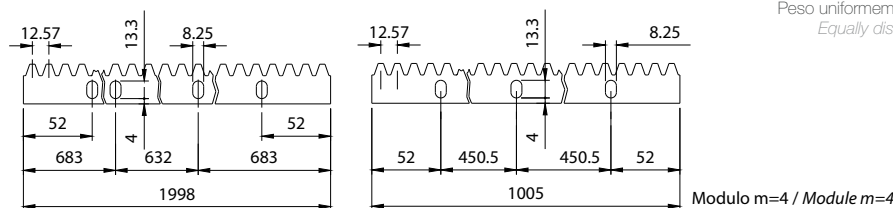

Peso uniformemente distribuito
Equally distributed weight

Mounting instructions art. 262

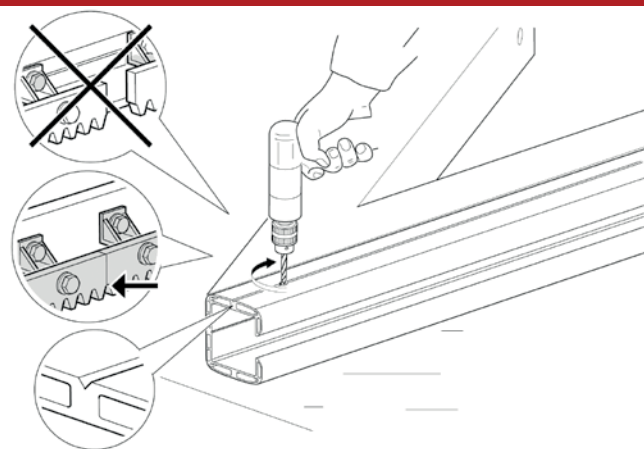

1

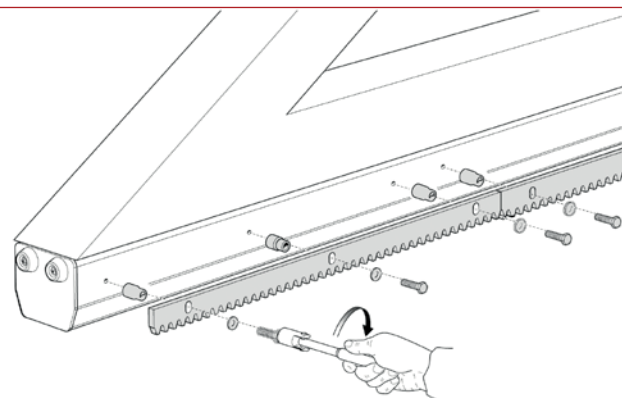

2



La divisione fa la forza

Quattro divisioni che esprimono quelli che sono i valori di Comunello: qualità assoluta, alta precisione, ricerca e innovazione. Ogni progetto è apertura verso il futuro e riferimento sicuro per i settori specifici di ciascuna divisione.

COMUNELLO
GATE DIVISION

COMUNELLO
AUTOMATION

COMUNELLO
FRAME DIVISION

COMUNELLO
FRAME AUTOMATION





PORTONI INDUSTRIALI
INDUSTRIAL DOOR SYSTEMS



Industrial folding doors

Configuratore portoni ad anta.
Scegli dalla nostra gamma di componenti
di alta qualità.

Folding doors configurator.
Choose from our vast range of
high quality components.



Carrelli e perni
Trolleys and pins



ART.	PAG.
8	284
8C	284
10	284
10C	285
14C	285
16C	285
20C	266
375P	306
375G	307
376P	307
377	307
377R	308
377G-SC	308
395 DX-SX	309
396	310

Accessori
Accessories



ART.	PAG.
249-30	296
387	308
239	295
246	295

Cariglioni
Lever bolts



ART.	PAG.	ART.	PAG.
690MC	318	695G	322
693MC	321	695PM	323
694MC	321	695GM	323
696MC	324	680	315
698MC	325	682	316
691P	319	683	316
691G	319	684	316
692P	320	685	317
692G	320	686	317
693 MC	321	687	317
695P	322		

Incontri e battenti
Strikes and stops



ART.	PAG.
358	301
379	305
361	302
362	302
363	302
364	303
366	304
367	303
378	305

Monorotaie e supporti
Monorails and supports

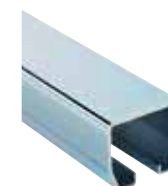

ART.	PAG.
26	266
28	289
34	290
398	311
399	311
352	298
354-185	299
354-330	299
355	300
355S	301
356	301

Cerniere e accessori
Hinges and accessories



ART.	PAG.	ART.	PAG.
A370P	326	P368S	330
A371P	326	P368M	330
A380P	327	P370	330
A381P	328	P371	331
A380G	326	P380	331
A380R	327	P381	331
A381G	327	P385	332
A384P	328	R383-13.5	332
A385P	328	R383-33	332
P365	329	R378	333
P365R	329	400	333
P368I	329		



Industrial sliding doors

Configuratore portoni scorrevoli.
Scegli dalla nostra gamma di componenti
di alta qualità.

Sliding doors configurator.
Choose from our vast range of
high quality components.



Monorotaie e accessori
Monorails and accessories

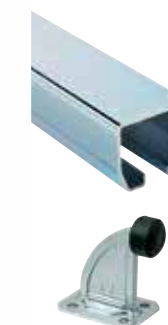

ART.	PAG.
22	287
23	288
24	286
30	289
32	289
36	290
398G	311
399P	311
352	298
354-185	299
354-330	299
355	300
355S	301
356	301
246	295
200G	76
202G	77
202F-A	77

Cariglioni
Lever bolts



ART.	PAG.	ART.	PAG.
690MC	318	695G	322
693MC	321	695PM	323
694MC	321	695GM	323
696MC	324	680	315
698MC	325	682	316
691P	319	683	316
691G	319	684	316
692P	320	685	317
692G	320	686	317
693 MC	321	687	317
695P	322		

Maniglioni a tirare
Strikes and stops



ART.	PAG.
671	312
672	312
674	313
675	313
677	313
678	314
679	314
679i	314
270	296
270i	297
272	297

Carrelli
Trolleys



ART.	PAG.	ART.	PAG.
2	282	48	293
2C	282	50	293
4	282	52	294
4C	283	54	294
38	290	56	294
39	291	60	295
40	291	248	296
41	291	375G	307
43	292	375P	306
44	292	376P	307
46	293	377G-SC	308



2

Carrello a 2 ruote
Trolley with 2 wheels
Chariot à 2 galets
Zweiadriger Rollenapparat
Carro con 2 ruedas
Тележка с 2 колесами



CODE	ART.	Size	Portata Capacity	Box info	
				Pcs per pack	Kg
10100505 001	2	Piccolo Ø 24	30 kg	16	1,2

Finishing: Zincato / Galvanized

Categoria commerciale: 1C

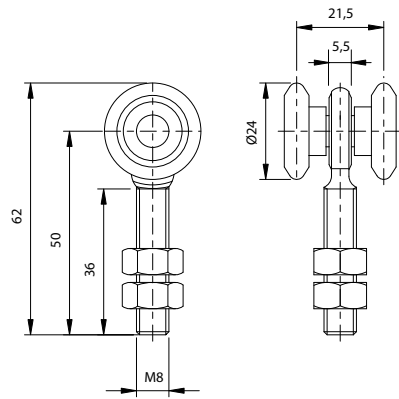

2C

Carrello a 2 ruote con cuscinetto
Trolley with two wheels and bearing
Chariot à 2 galets avec roulement
Zweiadriger Rollenapparat mit Kugellager
Carro con 2 ruedas con rodamiento
Тележка с 2 колесами с подшипником



CODE	ART.	Size	A	B	D	I	H	M	S	Portata ruota Capacity wheel	Box info	
											Pcs per pack	Kg
10100610 001	2C	Medio Ø44	105	65	Ø44	22	127	M12	8	250	16	5,00
10100615 001	2C	Grande Ø54	122	80	Ø54	30	149	M20	10	350	16	10,80

Finishing: Zincato / Galvanized

Categoria commerciale: 1C

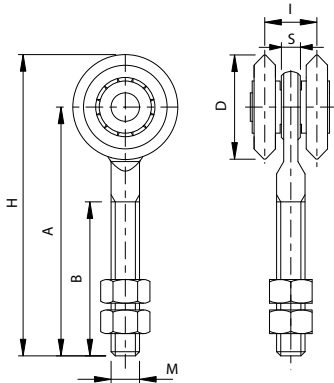

2 CUSCINETTI
2 BEARINGS

4

Carrello a 4 ruote
Trolley with four wheels
Chariot à 4 galets
Vierradriger Rollenapparat
Carro con 4 ruedas
Тележка с 4 колесами



CODE	ART.	Size	Portata ruota Capacity wheel	Box info	
				Pcs per pack	Kg
10101005 001	4	Piccolo Ø 24	50 kg	16	2,1

Finishing: Zincato / Galvanized

Categoria commerciale: 1C

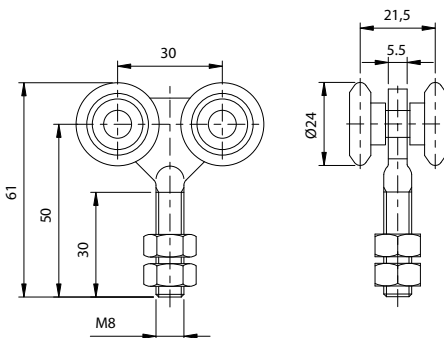

4C

Carrello a 4 ruote con cuscinetto
Trolley with four wheels and bearing
Chariot à 4 galets avec roulement
Vierradriger Rollenapparat mit Kugellager
Carro con 4 ruedas con rodamiento
Тележка с 4 колесами с подшипником



CODE	ART.	Size	A	B	C	D	H	I	M	S	Portata ruota Capacity wheel	Box info	
												Pcs per pack	Kg
10101110 001	4C	Medio Ø44	105	70	50	Ø44	127	22	M12	7	280	16	9,30
10101115 001	4C	Grande Ø54	125	80	60	Ø54	152	30	M20	10	400	16	19,60

Finishing: Zincato / Galvanized

Categoria commerciale: 1C

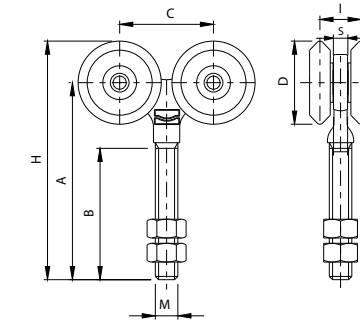

4 CUSCINETTI
4 BEARINGS

PATENTED

Mounting instructions art. 4C

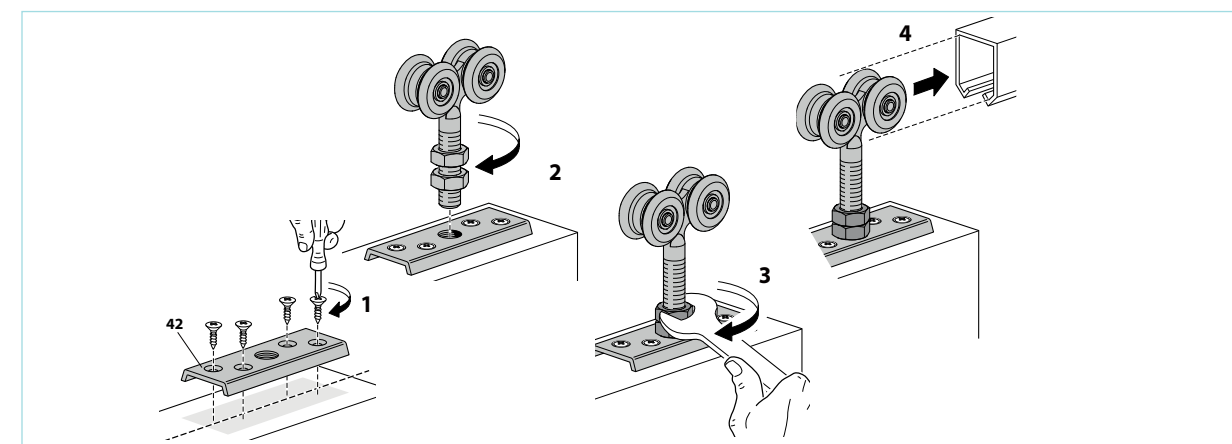
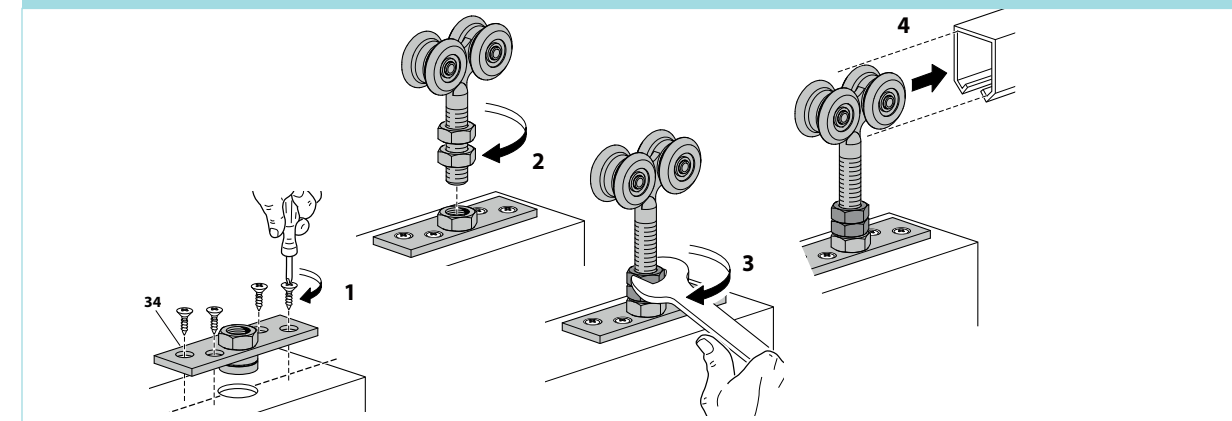



8

Carrello a 2 ruote girevole
Turning trolley with two wheels
Chariot à 2 galets pivotant
Zweiadriger Schwenkrollenapparat
Carro con 2 ruedas giratorias
Тележка с 2 поворотными колесами



CODE	ART.	Size	Portata Capacity	Box info	
				Pcs per pack	Kg
10102005 001	8	Piccolo Ø 24	30 kg	16	1,8

Finishing: Zincato / Galvanized

Categoria commerciale: 1C

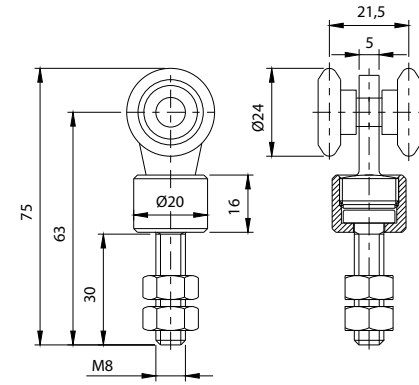

8C

Carrello a 2 ruote girevole con cuscinetti
Turning trolley with two wheels and bearings
Chariot à 2 galets pivotant avec roulements
Zweiadriger Schwenkrollenapparat mit Kugellagern
Carro con 2 ruedas giratorias con rodamientos
Тележка с 2 поворотными колесами с подшипниками



CODE	ART.	Size	A	B	D	E	F	H	I	M	S	Portata ruota Capacity wheel	Box info	
													Pcs per pack	Kg
10102110 001	8C	Medio Ø44	128	68,5	Ø44	Ø42	30	150	22	M12	7,5	250	16	10,70
10102115 001	8C	Grande Ø54	154,5	80,5	Ø54	Ø50	32	181,5	30	M18	10	350	16	19,90

Finishing: Zincato / Galvanized

Categoria commerciale: 1C

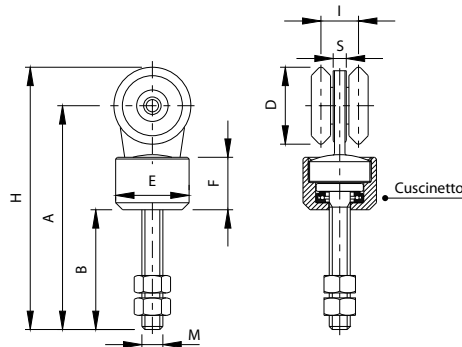

2 CUSCINETTI
2 BEARINGS

PATENTED

10

Carrello a 4 ruote girevole
Turning trolley with four wheels
Chariot à 4 galets pivotant
Vierradriger Schwenkrollenapparat
Carro con 4 ruedas giratorias
Тележка с 4 поворотными колесами



CODE	ART.	Size	Portata Capacity	Box info	
				Pcs per pack	Kg
10102505 001	10	Piccolo Ø 24	50 kg	16	2,7

Finishing: Zincato / Galvanized

Categoria commerciale: 1C

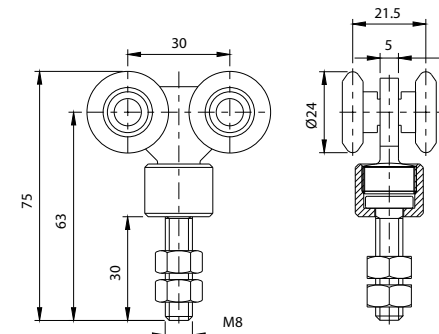

10C

Carrello a 4 ruote girevole con cuscinetti
Turning trolley with four wheels and bearings
Chariot à 4 galets pivotant avec roulements
Vierradriger Schwenkrollenapparat mit Kugellagern
Carro con 4 ruedas giratorias con rodamientos
Тележка с 4 поворотными колесами с подшипниками



CODE	ART.	Size	A	B	C	D	E	F	H	I	M	S	Portata ruota Capacity wheel	Box info	
														Pcs per pack	Kg
10102610 001	10C	Medio Ø44	128	68,5	50	Ø44	Ø42	30	150	22	M12	7,5	280	16	15,00
10102615 001	10C	Grande Ø54	154,5	80,5	60	Ø54	Ø50	32	181,5	30	M18	10	350	16	27,00

Finishing: Zincato / Galvanized

Categoria commerciale: 1C

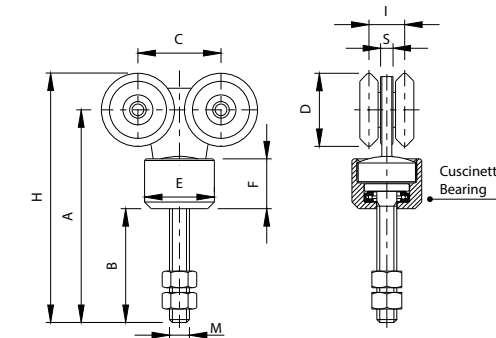

4 CUSCINETTI
4 BEARINGS

PATENTED

14C

Carrello a 2 ruote con cuscinetti e cerniera ad 1 ala
Trolley with two wheels, bearings and one wing hinge
Chariot avec 2 galets, roulements et paumelle à 1 aile
Zweiadriger Rollenapparat mit Kugellager und 1-Lasche-Torband
Carro con 2 ruedas con rodamientos y pernio de 1 pala
Тележка с 2 колесами с подшипниками и шарниром с 1 полкой



CODE	ART.	Size	A	D	E	F	H	I	L	M	S	Portata ruota Capacity wheel	Box info	
													Pcs per pack	Kg
10103110 001	14C	Medio Ø44	147	Ø44	25	Ø17,6	169	22	83	M12	7,5	250	16	7,90
10103115 001	14C	Grande Ø54	180,5	Ø54	27	Ø19,6	207,5	30	98	M12	10	270	16	14,10

Finishing: Zincato / Galvanized

Categoria commerciale: 1C

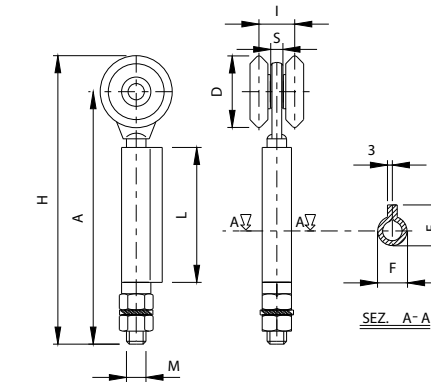

2 CUSCINETTI
2 BEARINGS

PATENTED

16C

Carrello a 4 ruote con cuscinetti e cerniera 3 ali
Trolley with four wheels, bearings and 3 wings hinge
Chariot avec 4 galets, roulements et paumelle à 3 ailes
Vierradriger Rollenapparat mit Kugellager und 3-Lasche-Torband
Carro con 4 ruedas con rodamientos y pernio de 3 palas
Тележка с 4 колесами с подшипниками и шарниром с 3 полками



CODE	ART.	Size	A	B	C	D	E	F	H	I	L	M	S	Portata ruota Capacity wheel	Box info	
															Pcs per pack	Kg
10103610 001	16C	Medio Ø44	212	36	50	Ø44	25	Ø17,6	234	22	58	M12	7,5	280	16	14,30
10103615 001	16C	Grande Ø54	226	36	60	Ø54	27	Ø19,6	253	30	52	M12	10,0	300	16	23,00

Finishing: Zincato / Galvanized

Categoria commerciale: 1C

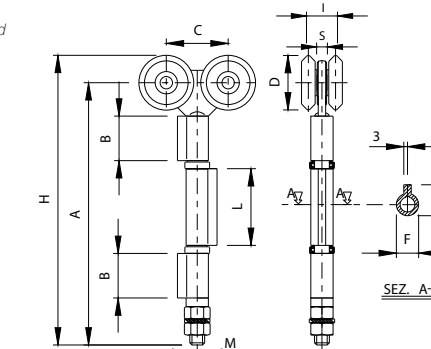

4 CUSCINETTI
4 BEARINGS

PATENTED



20C

Carrello a 4 ruote con cuscinetti e cerniera 1 ala

Trolley with four wheels, bearings and one wing hinge
Chariot avec 4 galets, roulements et paumelle à 1 aile
Vierdrücker Rollenapparat mit Kugellager und 1 Lasche-Torband
Carro con 4 ruedas con rodamientos y pernio de 1 pala
Тележка с 4 колесами с подшипниками и шарниром с 1 полкой



CODE	ART.	Size	A	C	D	E	F	H	I	L	M	S	Portata ruota Capacity wheel		Box info	
													Pcs per pack	Kg	Pcs per pack	Kg
10104610 001	20C	Medio Ø44	147	50	Ø44	25	Ø17,6	169	22	83	M12	7,5	280	16	12,40	
10104615 001	20C	Grande Ø54	199,5	60	Ø54	27	Ø19,6	226,5	30	98	M12	10	300	16	23,50	

Finishing: Zincato / Galvanized

Categoria commerciale: 1C

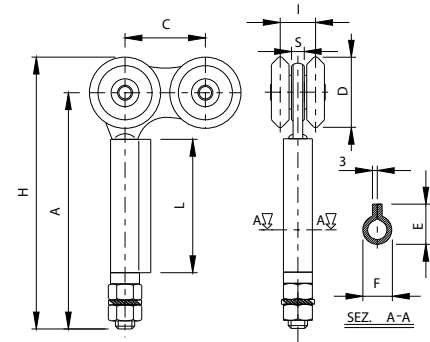

PATENTED

22

Supporto a soffitto per monorotaia art. 24

Ceiling support for track art.24
Support au plafond pour rail art.24
Decke-Lager für Stahlprofil Artikel 24
Soporte de techo para monocaril art. 24
Потолочная опора для монорельса арт.24



CODE	ART.	Size	A	B	C	D	S	Box info	
								Pcs per pack	Kg
10605005 001	22	Piccolo	41	48	54	110	3	10	3,50
10605000 001	22	Medio	52	73	64	120	4	10	4,60
10605010 001	22	Grande	66	88	74	130	4	6	3,90

Finishing: Zincato / Galvanized

Categoria commerciale: 1L

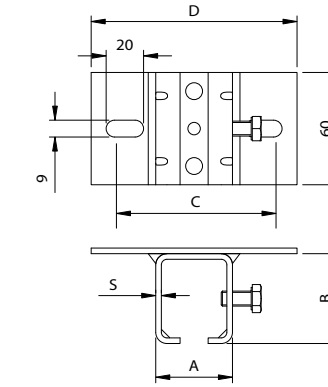

24

Monorotaia per carrello piccolo medio grande

Track for trolleys small-medium-large
Rail pour chariots petit-moyen-grand
Stahlprofil für Rollenaufhängung klein, medium, groß
Monocaril para carro pequeño mediano grande
Монорельс для больших средних и малых тележек



CODE	ART.	Size	B	C	H	L	S	Box info	
								Pcs per pack	Kg
10200505 001	24	Piccolo L=6000	34	21,5	30	6000	1,5	1	10,00
10200510 001	24	Medio L=6000	43	22	53	6000	2,5	1	19,00
10200515 001	24	Grande L=6000	57	30	68	6000	3	1	30,00

Finishing: Zincato / Galvanized

Categoria commerciale: 1I

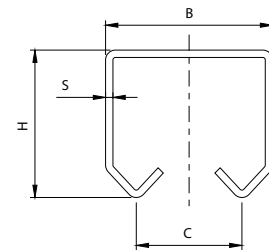

26

Perno inferiore con cerniera a 1 ala oliva in ottone

Bottom pivot with 1 wing hinge and brass roller
Pivot inférieur avec paumelle à 1 aile et rouleau en laiton
Unteres Führungsband mit 1-Lasche und Führungrolle aus Messing
Perno inferior con pernio de 1 pala rodillo de latón
Нижний штырь с шарниром с 1 полкой латунный наконечник



CODE	ART.	Size	E	F	L	M	R	Box info	
								Pcs per pack	Kg
10300505 001	26	Medio	25	Ø17,6	83	M12	165 - 180	16	5,70
10300510 001	26	Grande	27	Ø19,6	98	M14	185 - 200	16	7,60

Finishing: Zincato / Galvanized

Categoria commerciale: 1L

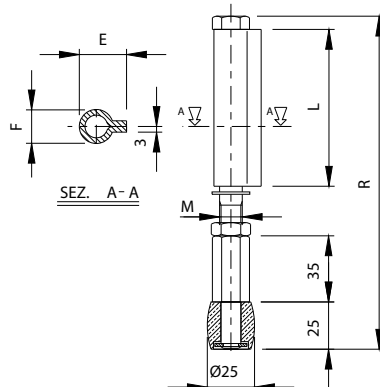

Mounting instructions art. 22

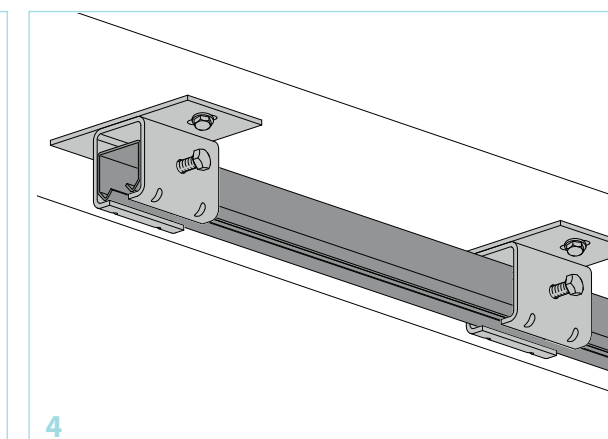
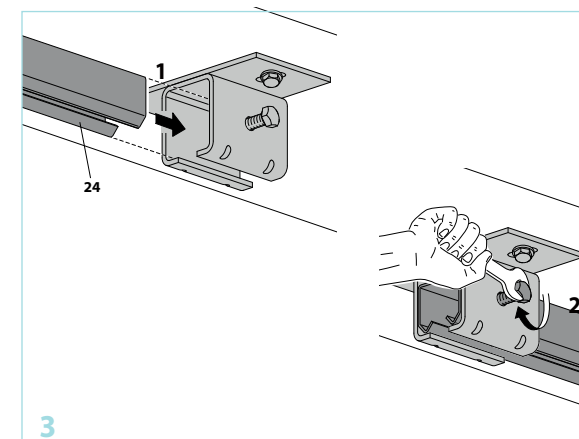
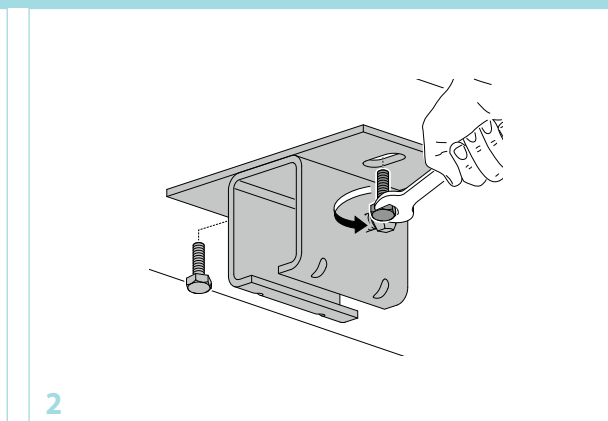
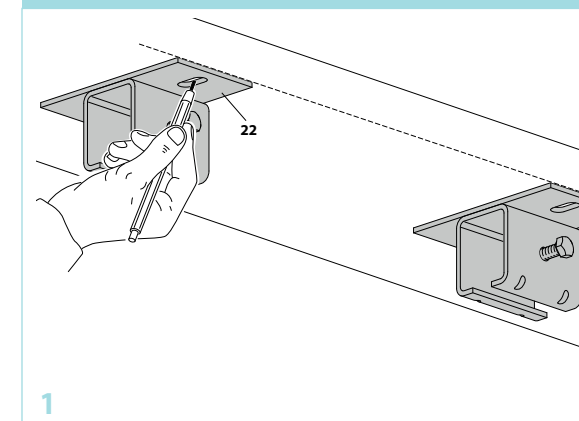



23

Supporto a parete per monorotaia
art. 24

Wall support for track art.24
Support au mur pour rail art.24
Wand-Lager für Stahlprofil Artikel 24
Soporte de pared para monorail art. 24
Настенная опора для монорельса art.24



CODE	ART.	Size	A	B	C	R	S	Box info	
								Pcs per pack	Kg
10605505 001	23	Piccolo	41	48	59	21-41	3	10	3,70
10605500 001	23	Medio	52	73	69	25-45	4	10	4,00
10605510 001	23	Grande	66	88	79	35-52	4	6	4,10

Finishing: Zincato / Galvanized

Categoria commerciale: 1L

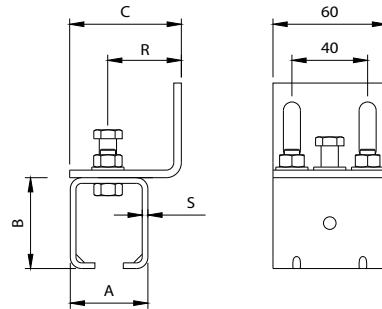

Mounting instructions art. 23

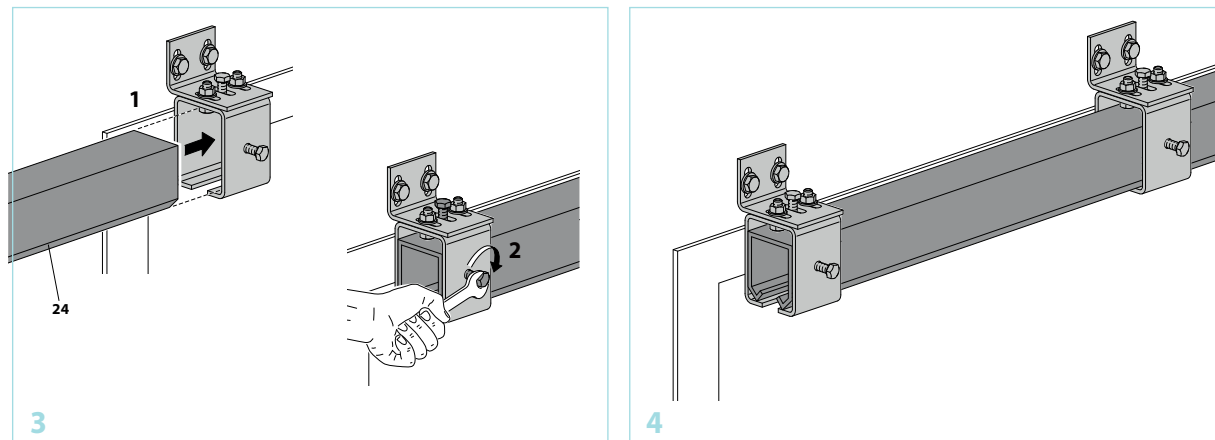
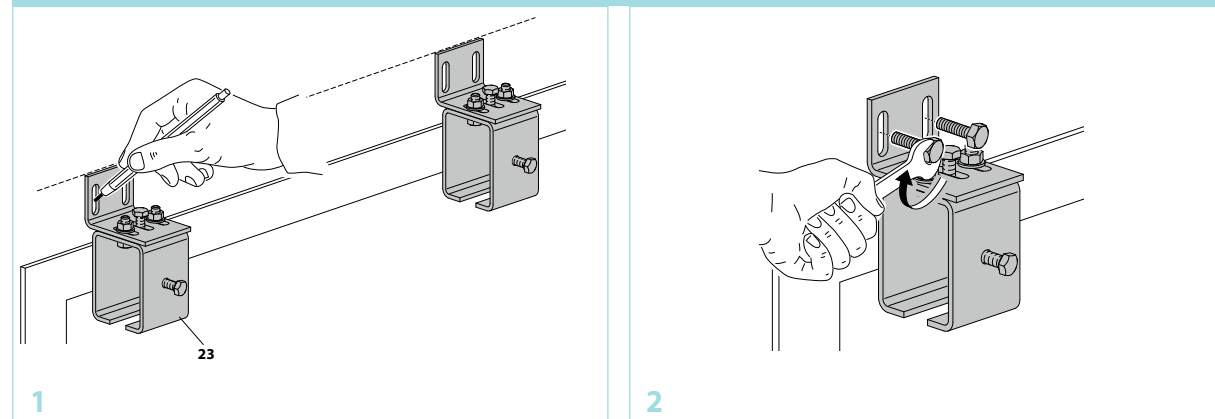

28

Perno inferiore con cerniera a 3 ali
oliva ottone

Bottom pivot with 3 wings hinge and brass roller
Pivot inférieur avec paumelle à 3 ailes et rouleau en laiton
Unteres Führungsrolle mit 3-Lasche und Führungsrolle aus Messing
Perno inferior con perno de 3 palas rodillo de latón
Нижний штырь с шарниром с 3 полками латунный наконечник



CODE	ART.	Size	B	E	F	L	M	R	Box info	
									Pcs per pack	Kg
10301005 001	28	Medio	36	25	Ø17,6	58	M12	225 - 235	16	7,80
10301010 001	28	Grande	36	27	Ø19,6	52	M14	227 - 242	16	9,00

Finishing: Zincato / Galvanized

Categoria commerciale: 1L

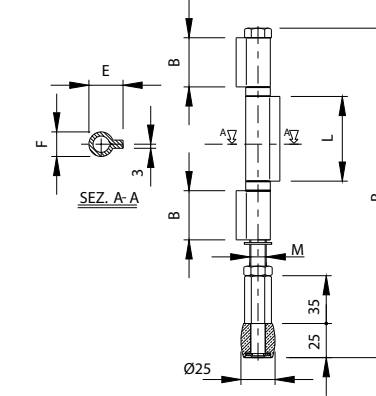

30

Perno filettato oliva in ottone

Threaded pivot with brass roller
Pivot taraudé avec rouleau en laiton
Bolzen mit Gewinde und Führungsrolle aus Messing
Perno roscado rodillo de latón
Резьбовой штырь латунный наконечник



CODE	ART.	Size	Box info	
			Pcs per pack	Kg
10301505 001	30-25	Ø 25	20	3,00

Finishing: Zincato / Galvanized

Categoria commerciale: 1L

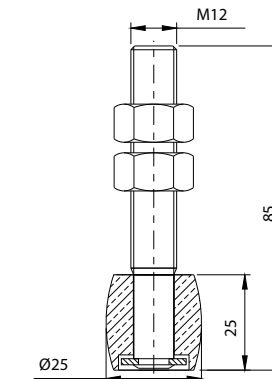

32

Deviatore rullo in acciaio

Steel switcher with roller
Déviateur en acier avec rouleau
Ablenker mit Stahlführungsrolle
Desviador rodillo de acero
Отводящее устройство для ролика из стали



CODE	ART.	Size	Box info	
			Pcs per pack	Kg
10400505 001	32-34	Ø 34	20	5,20

Finishing: Zincato / Galvanized

Categoria commerciale: 1L

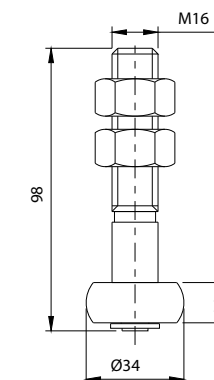



34

Piastra girevole con cuscinetto per carrelli

Turning plate with bearing for trolleys
Platine pivotante avec roulement pour chariots
Schwenkplatte mit Kugellager für Rollenapparate
Placa giratoria con rodamiento para carros
Поворотная пластина с подшипником для тележек



CODE	ART.	Size	A	B	D	F	H	M	S	Box info		
										Pcs per pack	Kg	
10500505 001	34-12	Medio	150	25	Ø24	Ø6,5	23,5	M12	5	22	20	3,60
10500510 001	34-20	Grande	150	40	Ø40	Ø10,5	31	M20	8	32	20	9,60

Finishing: Zincato / Galvanized

Categoria commerciale: 1L

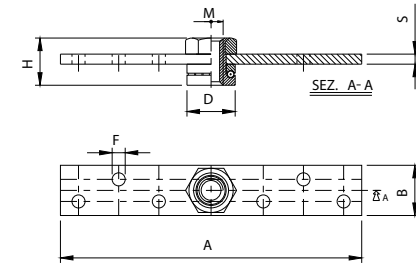

39

Carrello a 2 ruote in nylon

Trolley with 2 nylon wheels
Chariot avec 2 galets en nylon
Rollenapparat mit 2-Nylon-Rollen
Carro con 2 ruedas de nylon
Тележка с 2 колесами из нейлона



CODE	ART.	Size	Portata Capacity	Box info	
				Pcs per pack	Kg
10106005 001	39-24	Ø 24	30 kg	50	6,2

Finishing: Zincato / Galvanized

Categoria commerciale: 1C

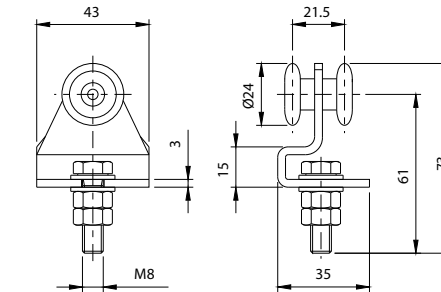

36

Guida inferiore oliva in ottone

Bottom guide with brass roller
Guide inférieure avec rouleau en laiton
Untere Führungsplatte mit Messing-Führungsrolle
Guía inferior rodillo de latón
Нижняя направляющая латунный наконечник



CODE	ART.	Size	A	B	C	D	E	F	G	H	S	Box info	
												Pcs per pack	Kg
10302005 001	36 - 25	Ø25	110	40	25	Ø25	19,5	Ø10,5	90	31	6	20	5,70
10302010 001	36 - 30	Ø30	110	40	25	Ø30	19,5	Ø10,5	90	31	6	20	6,50

Finishing: Zincato / Galvanized

Categoria commerciale: 1L

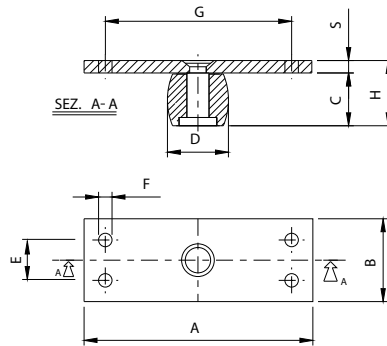

40

Carrello a 4 ruote

Trolley with 4 wheels
Chariot avec 4 galets
Vierdrücker Rollenapparat
Carro con 4 ruedas
Тележка с 4 колесами



CODE	ART.	Size	Portata Capacity	Box info	
				Pcs per pack	Kg
10106505 001	40-24	Ø 24	50 kg	50	11,9

Finishing: Zincato / Galvanized

Categoria commerciale: 1C

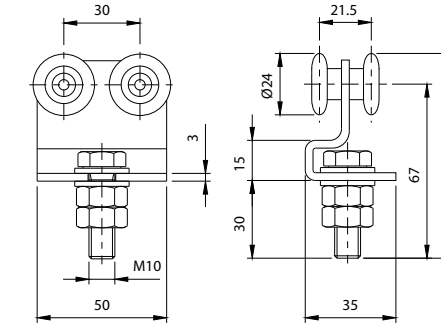

38

Carrello a 2 ruote

Trolley with 2 wheels
Chariot avec 2 galets
Zweiadrücker Rollenapparat
Carro con 2 ruedas
Тележка с 2 колесами



CODE	ART.	Size	Portata Capacity	Box info	
				Pcs per pack	Kg
10105505 001	38-24	Ø 24	30 kg	50	7,00

Finishing: Zincato / Galvanized

Categoria commerciale: 1C

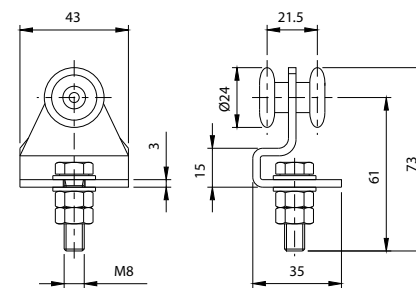

41

Carrello a 4 ruote in nylon

Trolley with 4 nylon wheels
Chariot avec 4 galets en nylon
Vierdrücker Rollenapparat mit Nylon-Rollen
Carro con 4 ruedas de nylon
Тележка с 4 колесами из нейлона



CODE	ART.	Size	Portata Capacity	Box info	
				Pcs per pack	Kg
10107005 001	41-24	Ø 24	50 kg	50	10,2

Finishing: Zincato / Galvanized

Categoria commerciale: 1C

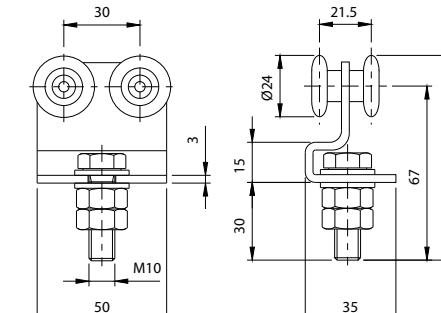



42

Piastrina per carrelli
Plate for trolleys
Plaque pour chariots
Platte für Rollenapparat
Placa para carros
Пластина для тележек



CODE	ART.	Size	M	Box info	
				Pcs per pack	Kg
10501005 001	42	Piccolo	M8	50	2,50
10501010 001	42	Grande	M10	50	2,50

Finishing: Zincato / Galvanized
Categoria commerciale: 1L

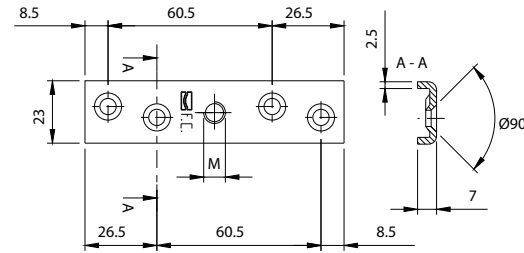

46

Carrello a 2 ruote con staffa
lunga zancata
Trolley with 2 wheels and long bended bracket
Chariot à 2 galets avec bride longue et courbée
Zweiwädriger Rollenapparat mit langem gekrüpitem Befestigungsbügel
Einwädriger Rollenapparat mit Befestigungsbügel
Carro con 2 ruedas con placa larga curvada
Тележка с 2 колесами с длинным выгнутым кронштейном



CODE	ART.	Size	Portata Capacity	Box info	
				Pcs per pack	Kg
10108505 001	46-24	Ø 24	30 kg	100	9,4

Finishing: Zincato / Galvanized
Categoria commerciale: 1C

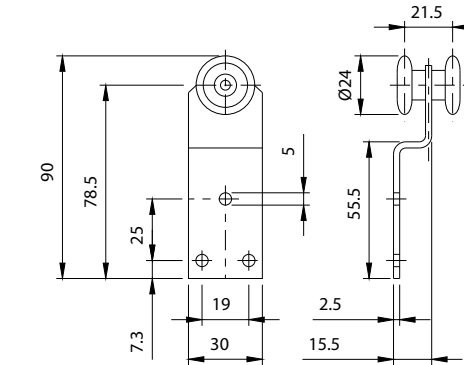

43

Carrello a 2 ruote con staffa
2 Wheels trolley with bracket
Chariot à 2 galets avec bride
Zweiwädriger Rollenapparat mit Befestigungsbügel
Carro con 2 ruedas con placa
Тележка с 2 колесами с кронштейном



CODE	ART.	Size	Portata Capacity	Box info	
				Pcs per pack	Kg
10107505 001	43-24	Ø 24	30 kg	100	7,5

Finishing: Zincato / Galvanized
Categoria commerciale: 1C

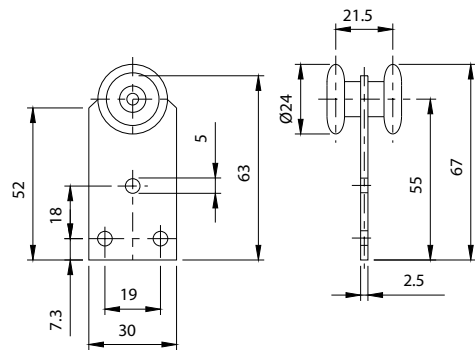

48

Carrello a 1 ruota con staffa
Trolley with 1 wheel and bracket
Chariot à 1 galet avec bride
Einwädriger Rollenapparat mit Befestigungsbügel
Carro con 1 rueda con placa
Тележка с 1 колесом с кронштейном



CODE	ART.	Size	Portata Capacity	Box info	
				Pcs per pack	Kg
10109005 001	48-24	Ø 24	15 kg	100	6,20

Finishing: Zincato / Galvanized
Categoria commerciale: 1C

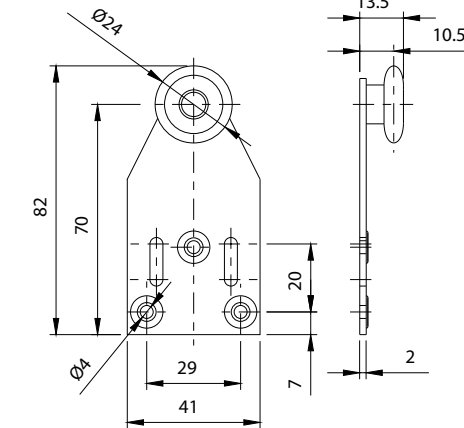

44

Carrello a 2 ruote con staffa lunga
2 Wheel trolley with long bracket
Chariot à 2 galets avec bride longue
Zweiwädriger Rollenapparat mit langem Befestigungsbügel
Carro con 2 ruedas con placa larga
Тележка с 2 колесами с длинным кронштейном



CODE	ART.	Size	Portata Capacity	Box info	
				Pcs per pack	Kg
10108005 001	44-24	Ø 24	30 kg	100	9,4

Finishing: Zincato / Galvanized
Categoria commerciale: 1C

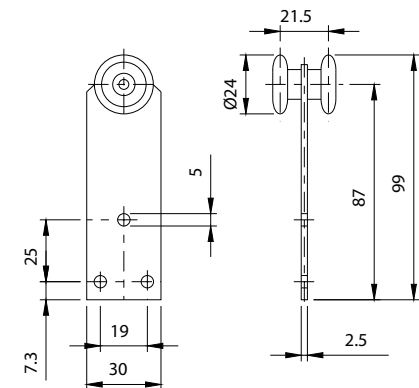

50

Carrello a 2 ruote con staffa
Trolley with 2 wheels and bracket
Chariot à 2 galets avec bride
Zweiwädriger Rollenapparat mit Befestigungsbügel
Carro con 2 ruedas con placa
Тележка с 2 колесами с кронштейном



CODE	ART.	Size	Portata Capacity	Box info	
				Pcs per pack	Kg
10109505 001	50-24	Ø 24	30 kg	100	8,40

Finishing: Zincato / Galvanized
Categoria commerciale: 1C

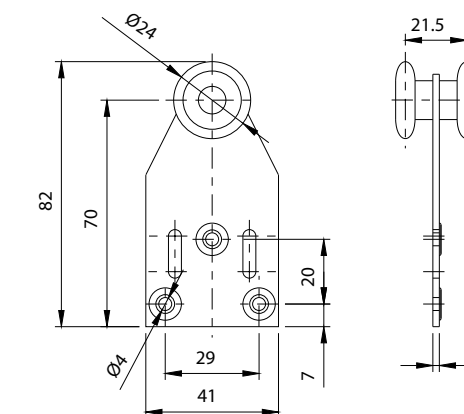



52

Carrello a 2 ruote con staffa zancata
Trolley with 2 wheels and bended bracket
Chariot à 2 galets avec bride courbée
Zweiadriger Rollenapparat mit gekrüpfem Befestigungsbügel
Carro con 2 ruedas con placa curvada
Тележка с 2 колесами с выгнутым кронштейном



CODE	ART.	Size	Portata Capacity	Box info	
				Pcs per pack	Kg
10110005 001	52-24	Ø 24	30 kg	100	8,20

Finishing: Zincato / Galvanized

Categoria commerciale: 1C

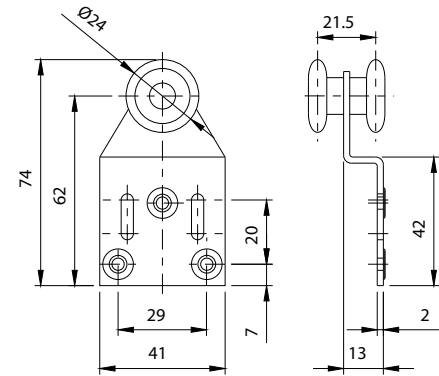

60

Carrello a 4 ruote con staffa porta gancio
Trolley with 4 wheels and hook holder bracket
Chariot à 4 galets avec bride porte-crochet
Vierradriger Rollenapparat mit Einhängbohrung
Carro con 4 ruedas con placa para gancho
Тележка с 4 колесами с кронштейном с крюком



CODE	ART.	Size	Portata Capacity	Box info	
				Pcs per pack	Kg
10111505 001	60-24	Ø 24	50 kg	50	9,60

Finishing: Zincato / Galvanized

Categoria commerciale: 1C

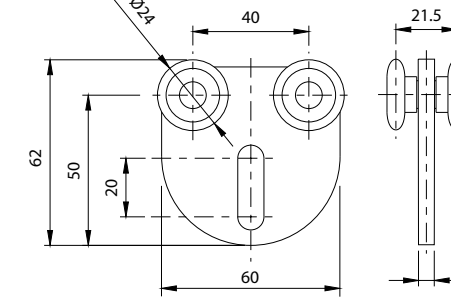

54

Carrello a 4 ruote con staffa larga
Trolley with 4 wheels and large bracket
Chariot à 4 galets avec bride large
Vierradriger Rollenapparat mit breitem Befestigungsbügel
Carro con 4 ruedas con placa ancha
Тележка с 4 колесами с широким кронштейном



CODE	ART.	Size	Portata Capacity	Box info	
				Pcs per pack	Kg
10110505 001	54-24	Ø 24	50 kg	100	16,00

Finishing: Zincato / Galvanized

Categoria commerciale: 1C

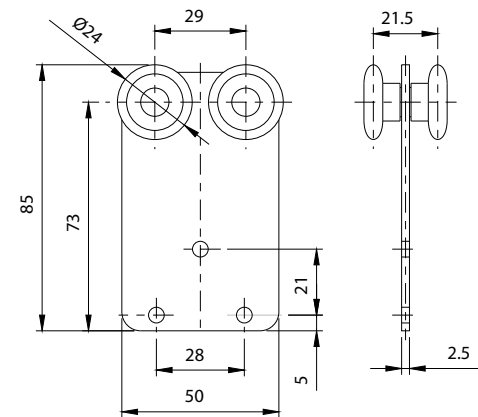

239

Tappo ammortizzatore ante
Door leaf stopper
Embout d'amortissage vantaux
Stossdämpfer für Türe
Amortiguador hojas
Амортизирующая пробка створки



CODE	ART.	Pcs per pack	Box info	
			Kg	Categoria commerciale
10700405	239	10	0,60	3E

Categoria commerciale: 3E

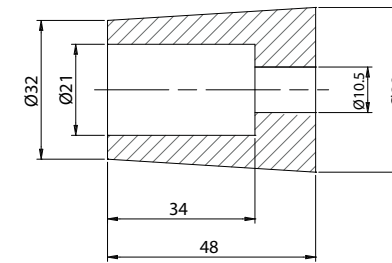

56

Carrello a 4 ruote con staffa larga zancata
Trolley with 4 wheels and large bended bracket
Chariot à 4 galets avec bride large courbée
Vierradriger Rollenapparat mit gekrüpfem breitem Befestigungsbügel
Carro con 4 ruedas con placa ancha curvada
Тележка с 4 колесами с широким выгнутым кронштейном



CODE	ART.	Size	Portata Capacity	Box info	
				Pcs per pack	Kg
10111005 001	56-24	Ø 24	50 kg	100	16,10

Finishing: Zincato / Galvanized

Categoria commerciale: 1C

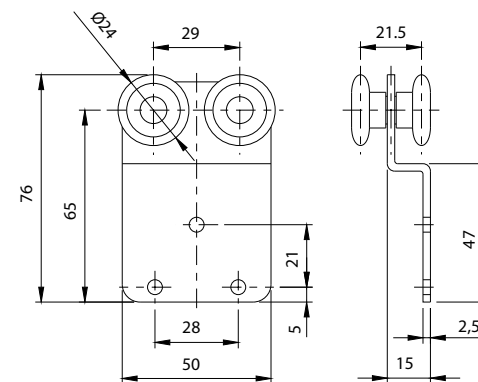

246

Battente finecorsa per monorotaie art. 398/399
End-stopper for guides art. 398/399
Butee de fin de course pour rails art. 398/399
Letzter Türflügel für Laufschienen art. 398/399
Tope para monocaril art. 398/399
Стопор конца хода для монорельсов art. 398/399



CODE	ART.	Size	Portata Capacity	Box info	
				Pcs per pack	Kg
10701705 001	246	Piccolo Ø 24	30 kg	4	1,3

Finishing: Zincato / Galvanized

Categoria commerciale: 3G

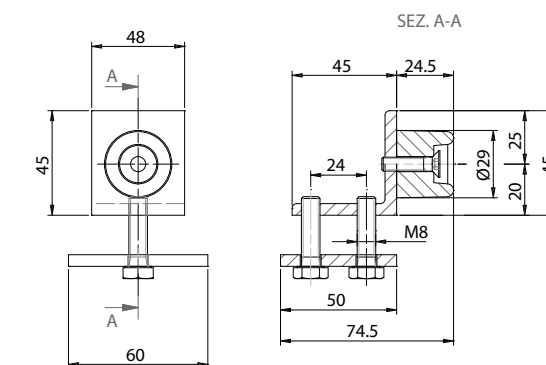



248

Guida per portoni scorrevoli
Guide for sliding doors
Guide pour portails coulissants
Führung für Schiebetüren
Guía para portones de corredera
Направляющая для раздвижных дверей



CODE	ART.	Size	Box info	
			Pcs per pack	Kg
11307500 001	248-60	Ø60	4	2,20
11307501 001	248-70	Ø70	4	1,80
11307505 001	248-80	Ø80	4	2,10

Finishing: Zincato / Galvanized

Categoria commerciale: 3H

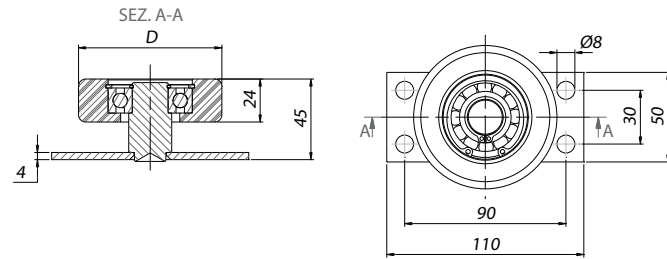

249-30

Deviatore regolabile per impacchettamento laterale
Adjustable switcher for side folding
Deviateur réglable pour portail pliable lateral
Regulierbarer Ablenker für seitliche Paket-Lagerung
Desviador regulable para puerta plegable
Регулируемое отклоняющее устройство для боковой завертки



CODE	ART.	Pcs per pack	Box info	
			Kg	
10401505 001	249-30	4	3,80	

Finishing: Zincato / Galvanized

Categoria commerciale: 3E

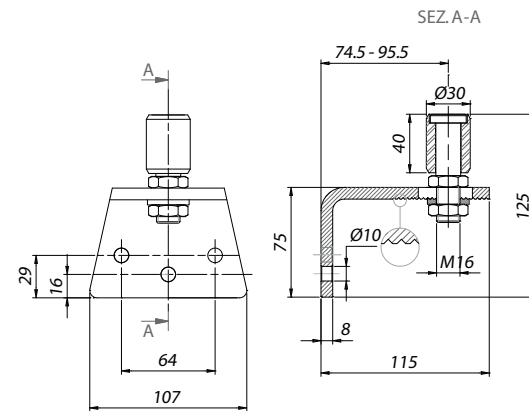

270

Maniglia ad incasso
Flush-mounted handle
Poignée à encaisser
Muschelgriff
Tirador encastrar
Встраиваемая ручка



CODE	ART.	Size	A	B	C	D	E	F	G	H	S	Box info	
												Pcs per pack	Kg
10902005 001	270P	Piccolo	52	115	42	105	20	Ø3	27	20	1	30	2,50
10902010 001	270G	Grande	90	200	76	186	35	Ø5	47	20	1,2	30	7,30

Finishing: Zincato / Galvanized

Categoria commerciale: 1H

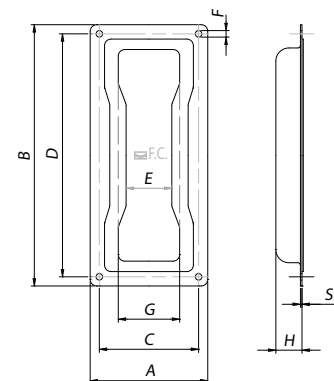

270i

Maniglia ad incasso
Flush-mounted handle
Poignée à encaisser
Muschelgriff
Tirador encastrar
Встраиваемая ручка



CODE	ART.	A	B	C	D	E	F	G	H	S	Box info	
											Pcs per pack	Kg
10902505	270i-P	52	115	42	105	20	Ø3	27	20	1	4	1,6
10902510	270i-G	90	200	76	186	35	Ø5	47	20	1,2	4	1,10

Finishing: Inox / Stainless steel

Categoria commerciale: 2H

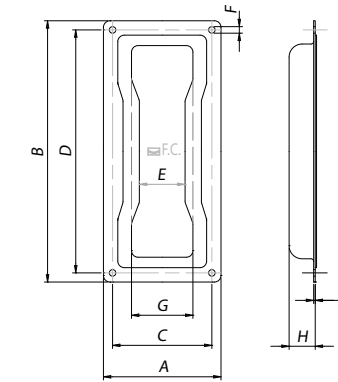

272

Maniglia ad incasso con leva
Flush-mounted handle with lever
Poignée à encaisser avec levier
Muschelgriff mit Triebriegel
Tirador encastrar con manilla
Встраиваемая ручка с рычагом



CODE	ART.	A	B	C	D	F	H	S	Box info	
									Pcs per pack	Kg
10903005 001	272	90	200	76	186	Ø5	20	1,20	30	11,40

Finishing: Zincato / Galvanized

Categoria commerciale: 1H

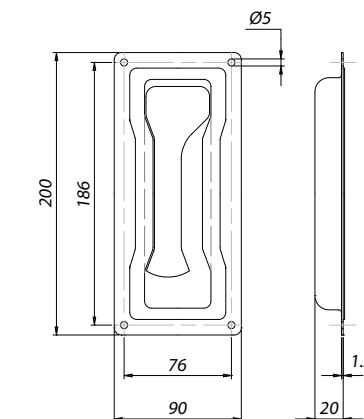



352

Giunzione monorotaia
Guide connection
Junction rail
Verbindungsstück Laufschiene
Empalme monocarril
Соединение монорельса



CODE	ART.	A	B	D	E	H	L	M	S	Box info	
										Pcs per pack	Kg
10602505 001	352P	86	30	76	65	75	180	M8	5	4	8,0
10602510 001	352G	113	40	103	91	101	200	M8	5	4	12,0

Finishing: Zincato / Galvanized

Categoria commerciale: 3G

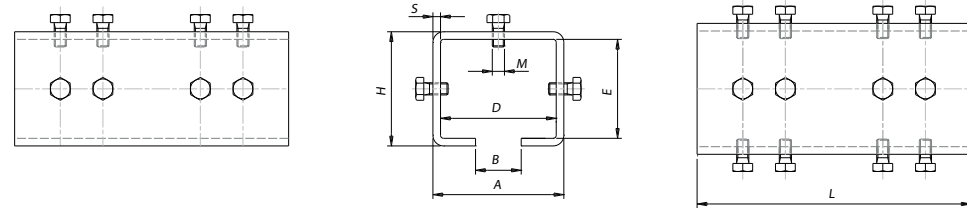

Mounting instructions art. 352

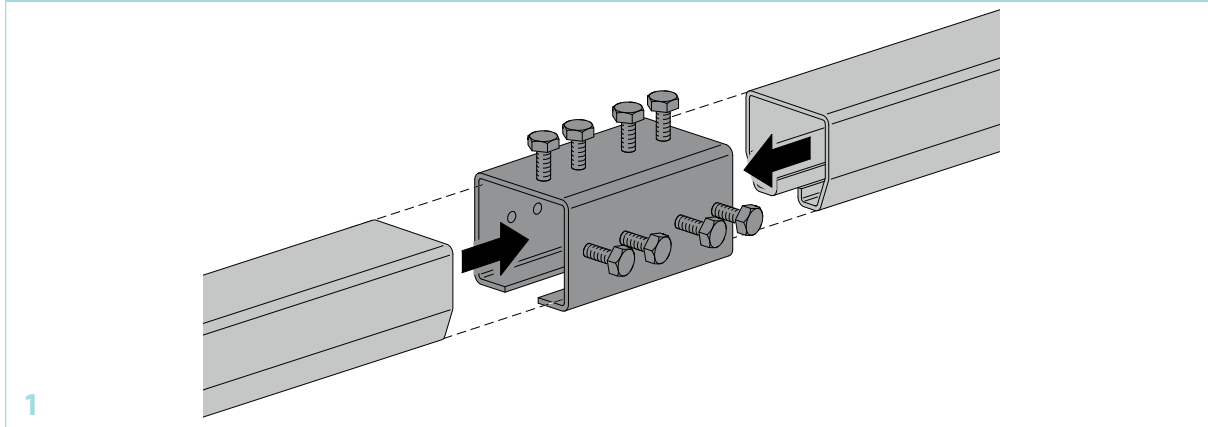

1

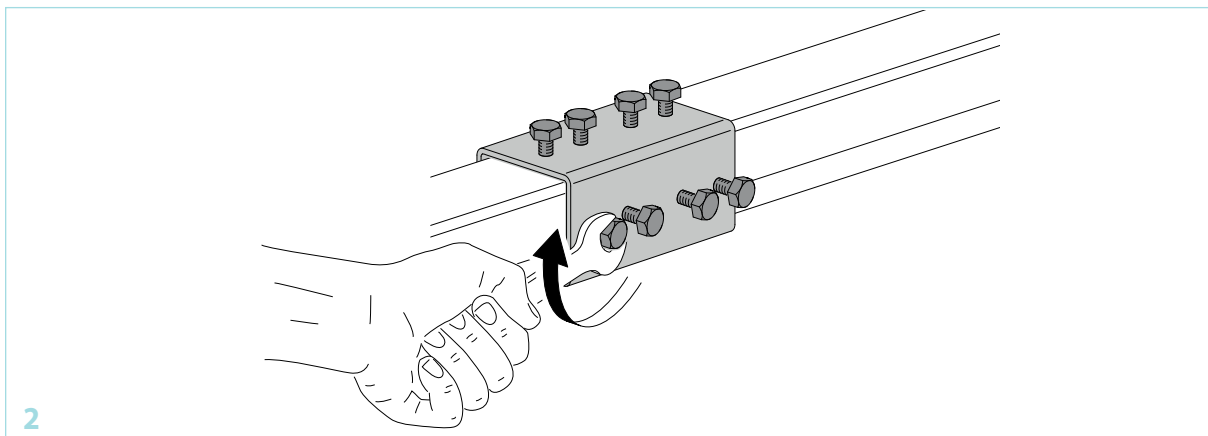

2

354-185

Staffa regolabile a parete mm. 185
Adjustable wall rod 185 mm.
Support réglable au mur mm. 185
Regulierbarer Wandbügel 185 mm.
Placa regulable de pared 185 mm
Регулируемый настенный кронштейн мм 185



CODE	ART.	Size	R	Portata Capacity	Box info	
					Pcs per pack	Kg
10603006 001	354-185	Piccolo	47-165	150 kg	2	3,0

Finishing: Zincato / Galvanized

Distanza massima raccomandata considerando un carico di R = 310 applicato sulla parte finale: 700 mm
Recommended maximum distance considering a load of R = 310 applied on the end part: 700 mm
Distance maximal recommandée considérant une charge de R = 310 appliquée sur la partie finale: 700 mm
Maximal empfohlene Entfernung bei einer am Endteil angebrachten Ladung von R=310 beträgt 700mm
Distancia máxima recomendada considerando una carga de R = 310 aplicada en la parte final: 700 mm
Максимальное рекомендуемое расстояние, с учетом нагрузки R = 310, прилагаемой к концевой части: 700 мм

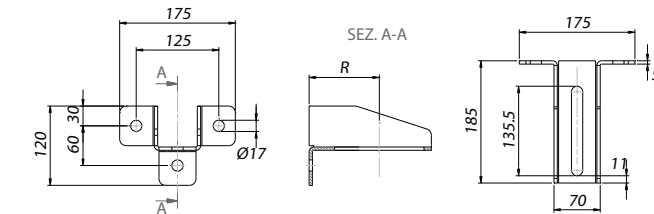

Mounting instructions art. 354-185

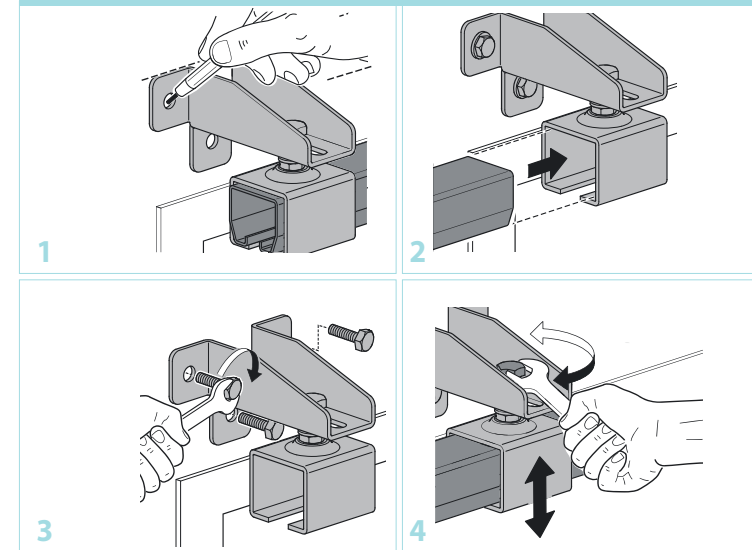

354-330

Staffa regolabile a parete mm. 330
Adjustable wall rod 330 mm.
Support réglable au mur mm. 330
Regulierbarer Wandbügel 330 mm
Placa regulable de pared 330 mm
Регулируемый настенный кронштейн мм 330



CODE	ART.	Size	R	Portata Capacity	Box info	
					Pcs per pack	Kg
10603011 001	354-330	Grande	47-310	130 kg	2	4,80

Finishing: Zincato / Galvanized

Categoria commerciale: 3G

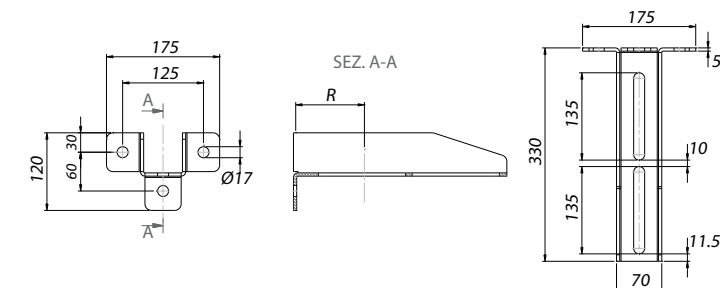

Distanza massima raccomandata considerando un carico di R = 310 applicato sulla parte finale: 700 mm
Recommended maximum distance considering a load of R = 310 applied on the end part: 700 mm
Distance maximal recommandée considérant une charge de R = 310 appliquée sur la partie finale: 700 mm
Maximal empfohlene Entfernung bei einer am Endteil angebrachten Ladung von R=310 beträgt 700mm
Distancia máxima recomendada considerando una carga de R = 310 aplicada en la parte final: 700 mm
Максимальное рекомендуемое расстояние, с учетом нагрузки R = 310, прилагаемой к концевой части: 700 мм



355

Supporto guida regolabile
Adjustable guide support
Support guide réglable
Regulierbarer Ablenker führung
Soporte guía regulable
Опора регулируемой направляющей



CODE	ART.	Size	A	B	D	E	H	L	M	P	Q	S	Portata Capacity	Box info	
														Pcs per pack	Kg
10603007 001	355 P	Piccolo	76	30	86	65	75	100	M16	83,5	150,5	5	150 kg	2	2,6
10603012 001	355 G	Grande	103	40	113	94	101	100	M16	109,5	176,5	5	200 kg	2	3,3

Finishing: Zincato / Galvanized
Categoria commerciale: 3G

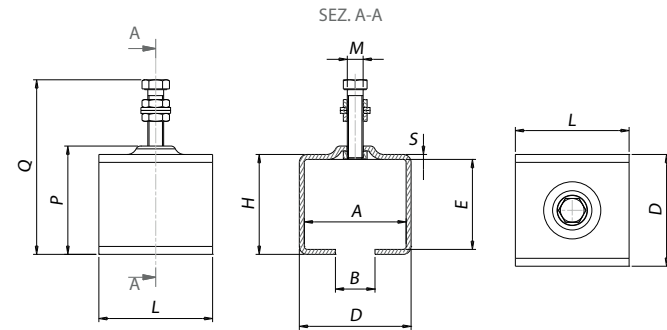

355 S

Supporto regolabile a saldare
Adjustable switchee to be welded
Deviateur réglable à souder
Regulierbarer Ablenker zum Schweissen
Soporte regulable para soldar
Привариваемая регулируемая опора



CODE	ART.	Portata Capacity	Box info	
			Pcs per pack	Kg
10603013 001	355 S	200 kg	4	2,1

Finishing: Zincato / Galvanized
Categoria commerciale: 3G

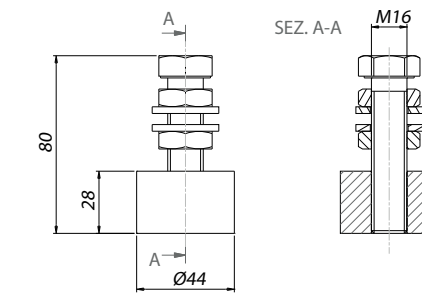

Mounting instructions art. 355

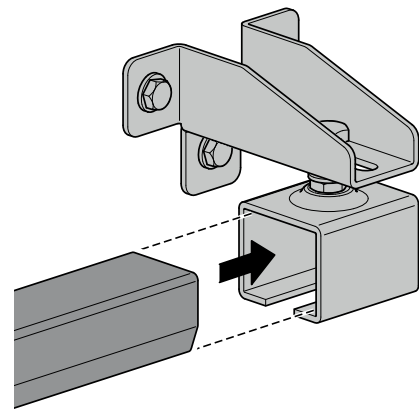

1

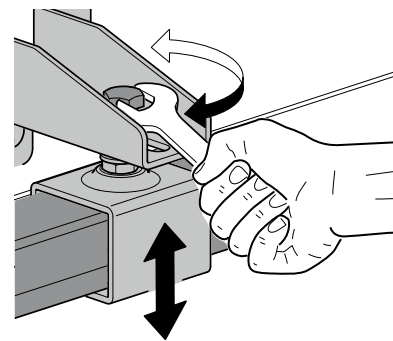

2

356

Supporto a soffitto
Adjustable switchee
Deviateur réglable au mur
Regulierbarer Ablenker
Soporte de techo
Потолочная опора



CODE	ART.	Size	A	B	D	E	F	G	H	L	M	N	Q	S	Portata Capacity	Box info	
																Pcs per pack	Kg
10604005 001	356 P	Piccolo	86	30	76	65	16	36	75	115	205	100	80	5	150 kg	2	4,1
10604010 001	356 G	Grande	113	40	103	94	16	36	101	115	205	100	106	5	200 kg	2	5,0

Finishing: Zincato / Galvanized
Categoria commerciale: 3G

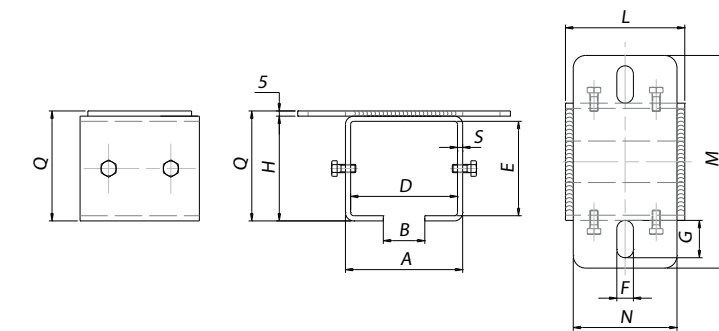

358

Guida inferiore a cementare da mt. 6,00
Lower guide to be cemented, length 6 meters
Guide inferieure à sceller de m. 6,00
Untere Schiene zum Einzementieren, Länge 6 m
Guía inferior para cementar de 6,00 m
Нижняя цементируемая направляющая м 6,00

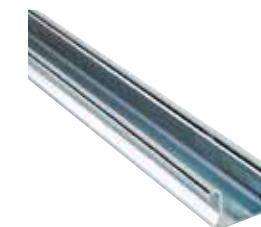

CODE	ART.	Size	Box info	
			Pcs per pack	Kg
10202010 001	358	L=6000	1	21,3

Finishing: Zincato / Galvanized
Categoria commerciale: 3G

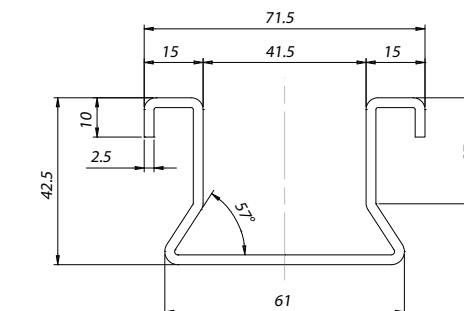



361

Incontro a pavimento in alluminio
Aluminium floor strike plate
Butoir au sol en aluminium
Bodenaufschuh aus Aluminium
Encuentro de aluminio para suelo
Алюминиевый напольный упор



CODE	ART.	Size	A	B	D	F	G	H	I	L	M	N	Box info	
													Pcs per pack	Kg
10702505	361 P	Piccolo	159	108	18	Ø8,5	16,5	30	80	50	41	50	2	1,2
10702510	361 G	Grande	159	109	22	Ø8,5	16,5	30	80	50	39	48	2	1,2

Finishing: Alluminio / Aluminium

Categoria commerciale: 3E

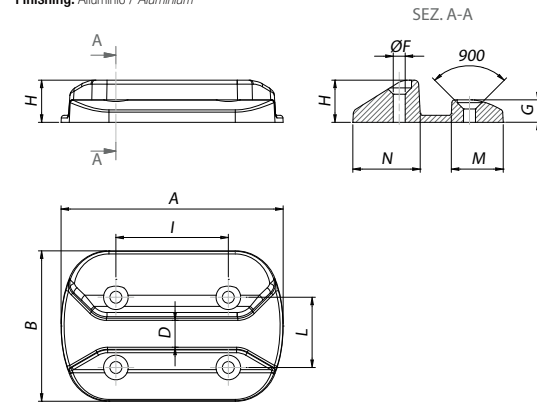

364

Incontro a pavimento in alluminio regolabile
Adjustable aluminium floor strike plate
Butoir au sol en aluminium réglable
Bodenaufschuh aus Aluminium regulierbar
Encuentro de aluminio regulable para suelo
Алюминиевый регулируемый напольный упор



CODE	ART.	Size	Box info	
			Pcs per pack	Kg
10702405	364	D=18-43	2	1,2

Finishing: Alluminio / Aluminium

Categoria commerciale: 3E

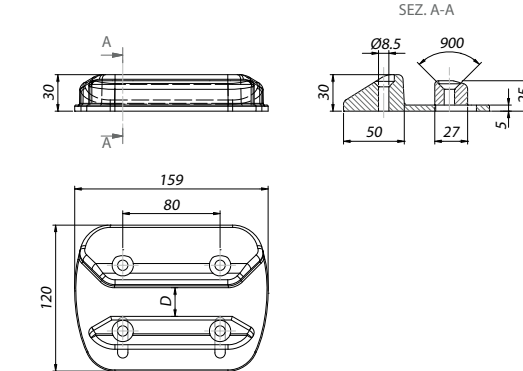

362

Battuta per ante intermedie in alluminio
Step for intermediate ante in aluminium
Butee pour vantaux intermédiaires en aluminium
Stütze für mittleren Türflügel aus Aluminium
Tope para hojas intermedias de aluminio
Упор для промежуточных створок из алюминия



CODE	ART.	Pcs per pack	Box info	
			Kg	
10702611	362	2	1,2	

Finishing: Alluminio / Aluminium

Categoria commerciale: 3E

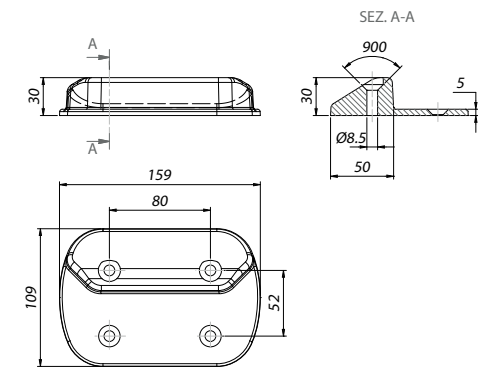

365

Incontro per aste
Floor strike plate for rods
Butoir pour tringles
Aufschuh für Stangen
Encuentro para varillas
Упор для стержней



CODE	ART.	Materiale Material	Finitura Finishing	Box info	
				Pcs per pack	Kg
10702905 001	365	Acciaio	Zincato	10	1,9
10702105	365 AL	Alluminio	Grezzo	10	1,9

Acciaio: Steel / Acier / Stahl / Acero / Сталь

Alluminio: Aluminium / Aluminium / Aluminium / Aluminium / Алюминий

Zincato: Galvanized / Galvanisé / Verzinkt / Galvanizado / Оцинкованная

Grezzo: Raw / Rûche / Rohstoff / Bruto / Необработанный

Categoria commerciale: 3E

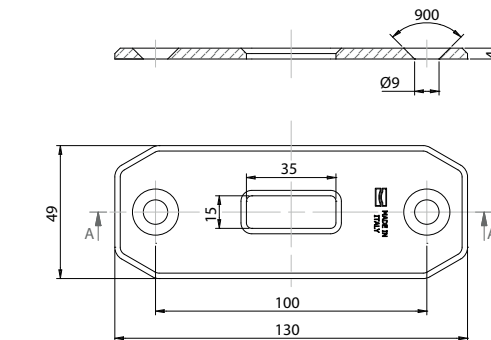

363

Incontro a pavimento in alluminio
Aluminium floor strike plate
Guidage au sol en aluminium
Bodenaufschuh aus Aluminium
Encuentro de aluminio para suelo
Алюминиевый напольный упор



CODE	ART.	Pcs per pack	Box info	
			Kg	
10702705	363	2	2,5	

Finishing: Alluminio / Aluminium

Categoria commerciale: 1G

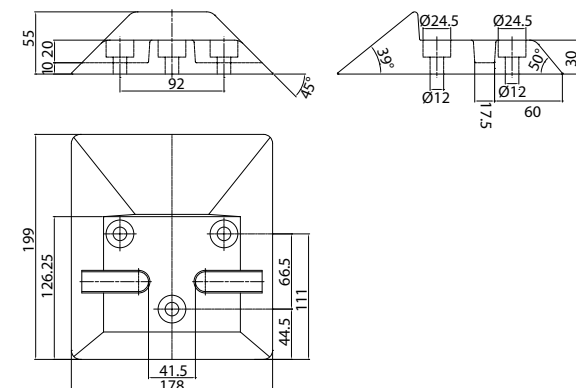

367

Incontro a pavimento in nylon nero, con rinforzo in acciaio
Black nylon floor strike plate, with steel reinforcement
Butoir au sol en nylon noir, avec renfort en acier
Bodenaufschuh aus schwarzem Nylon mit Verstärkung aus Stahl
Encuentro de nylon negro para suelo, con refuerzo de acero
Напольный упор из черного нейлона, со стальным укреплением



CODE	ART.	Pcs per pack	Box info	
			Kg	
10702305	367	2	0,6	

Categoria commerciale: 3E

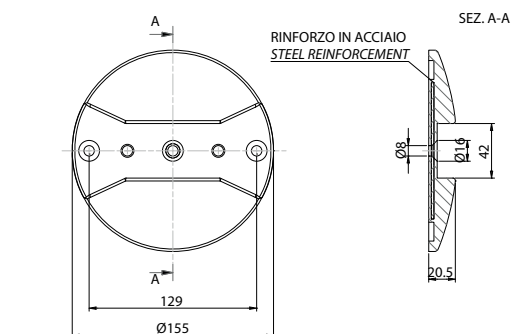



366

Incontro a pavimento per chiusura antipanico

Floor strike plate for panic exit device
Butoir au sol pour fermeture antipanique
Bodenaufschuh für Antipaniktür
Encuentro para suelo para cierre antipánico
Напольный упор для закрытия антипаник



CODE	ART.	Size	Box info	
			Pcs per pack	Kg
10702210	366-22	S=22	2	1,5
10702220	366-42	S=42	2	1,5

Finishing: Alluminio / Aluminium

Categoria commerciale: 3E

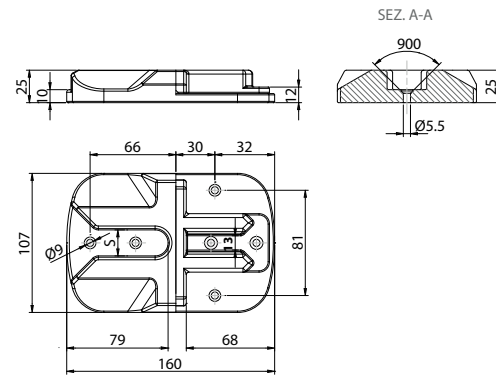

Mounting instructions art. 366

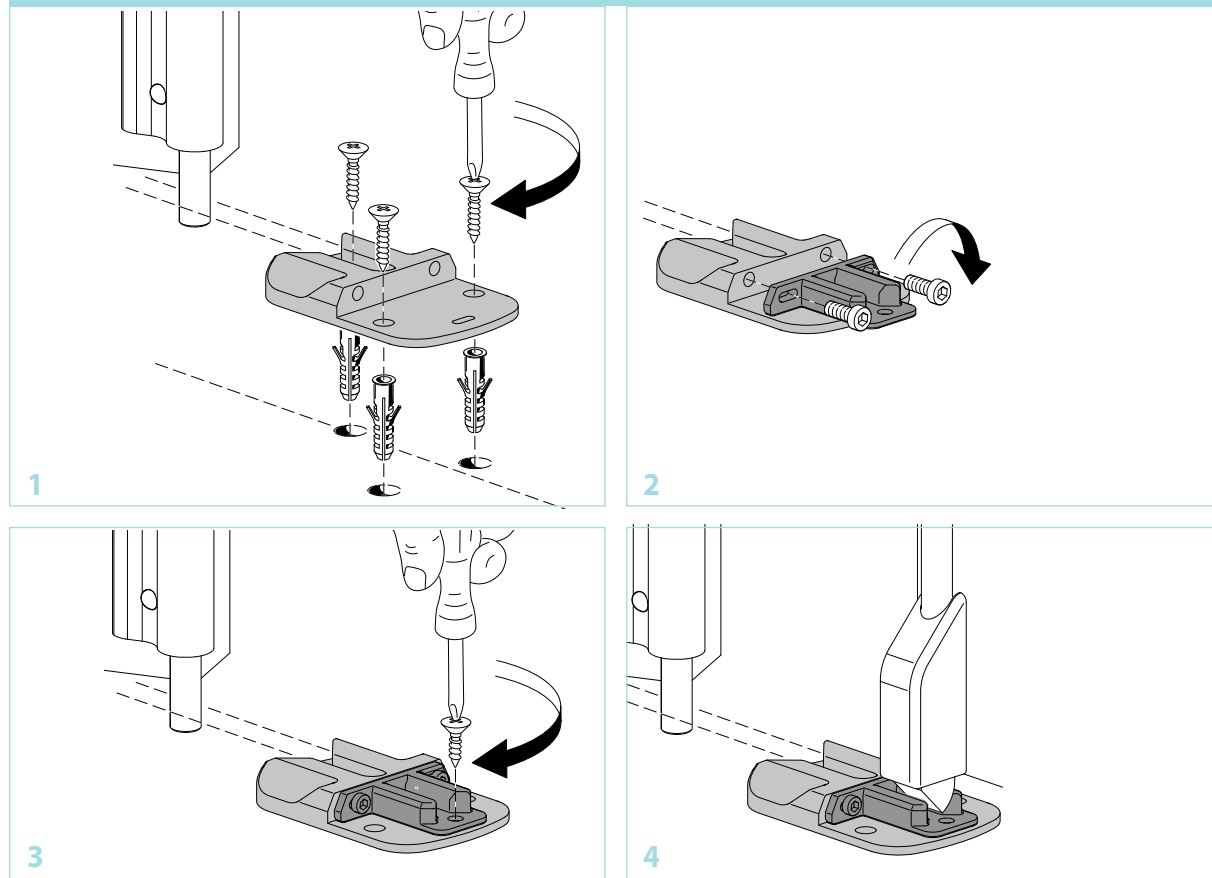

378

Perno inferiore regolabile

Adjustable lower pin
Pivot inférieur réglable
Unterer Bolzen regulierbar
Perno inferior regulable
Нижний регулируемый штифт



CODE	ART.	Size	A	B	D	L	Box info	
							Pcs per pack	Kg
10310505 001	378 P	Piccolo	13	37	16	130	4	0,8
10310510 001	378 G	Grande	18	50	20	182	4	1,8

Finishing: Zincato / Galvanized

Categoria commerciale: 3E

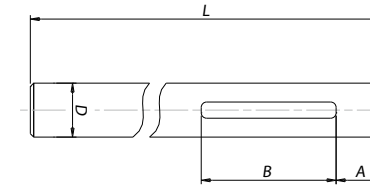

379

Perno inferiore regolabile con cuscinetto

Adjustable lower pin with bearing
Pivot inférieur réglable avec roulement
Unterer Bolzen mit Kugellager regulierbar
Perno inferior regulable con rodamiento
Нижний регулируемый штифт с подшипником



CODE	ART.	Size	A	B	D	L	R	S	Box info	
									Pcs per pack	Kg
10311005 001	379 P	Piccolo	13	37	16	142,5	32	10	4	1,0
10311008 001	379 G-135	Grande	5,5	37	20	135	40	12	4	1,5
10311008 003	379 G-135	Grande	5,5	37	20	135	40	12	4	1,5
10311010 001	379 G-200	Grande	18	50	20	200	40	12	4	2,2
10311010 003	379 G-200	Grande	18	50	20	200	40	12	4	2,2

Finishing: Zincato / Galvanized

Categoria commerciale: 3E

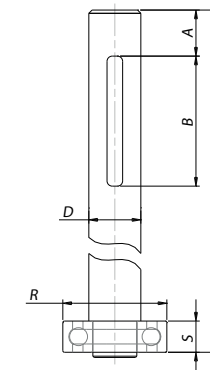



375 P

Carrello piccolo a 4 ruote in acciaio
Small steel trolley with four wheels
Chariot petit à 4 galets en acier
Rollenapparat klein mit 4 Stahlrollen
Carro pequeño con 4 ruedas de acero
Маленькая тележка с 4 колесами из стали



CODE	ART.	Size	A	Portata Capacity	Box info	
					Pcs per pack	Kg
10113007 001	375 P16	16 mm	Ø16,3	400 kg	4	3,2
10113006 001	375 P20	20 mm	Ø20,5	400 kg	4	3,2

Finishing: Zincato / Galvanized

Categoria commerciale: 3B

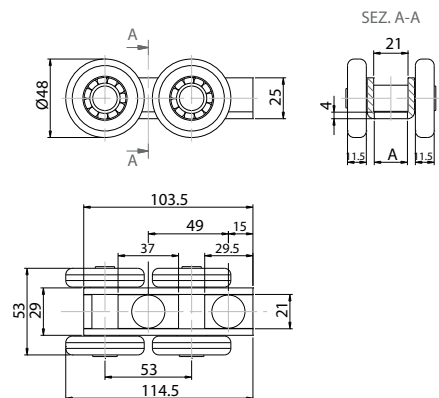

375 G

Carrello grande a 4 ruote in acciaio per perno da mm. 20
Large steel trolley with four wheels for pin, 20 mm.
Chariot grand à 4 galets en acier pour pivot de mm. 20
Rollenapparat gross mit 4 Stahlrollen
Carro grande con 4 ruedas de acero para perno de 20 mm
Большая тележка с 4 стальными колес для штифта мм 20



CODE	ART.	Size	Portata Capacity	Box info	
				Pcs per pack	Kg
10113010 001	375 G	Grande	800 kg	4	9,2

Finishing: Zincato / Galvanized

Categoria commerciale: 3B

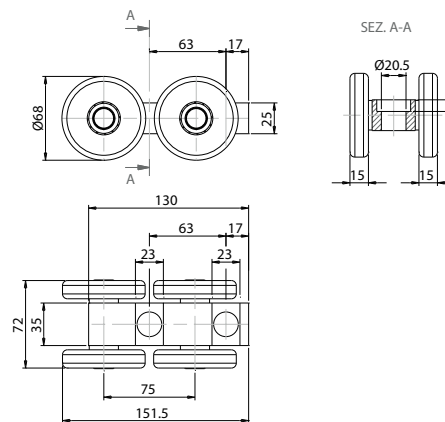

376 P

Carrello piccolo a 4 ruote in nylon
Small nylon trolley with four wheels
Chariot petit à 4 galets en nylon
Rollenapparat klein mit 4 Nylonrollen
Carro pequeño con 4 ruedas de nylon
Маленькая тележка с 4 нейлоновыми колесами



CODE	ART.	Size	A	Portata Capacity	Box info	
					Pcs per pack	Kg
10113402 001	376 P16	16 mm	Ø16,3	400 kg	4	2,1
10113401 001	376 P20	20 mm	Ø20,5	400 kg	4	2,1

Finishing: Zincato / Galvanized

Categoria commerciale: 3B

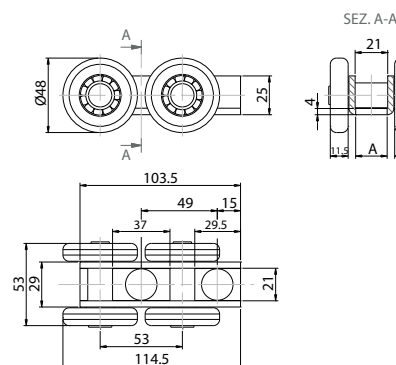

377

Perno superiore per carrelli
Upper pin for trolleys
Pivot supérieur pour chariots
Oberer Bolzen für Rollenapparate
Perno superior para carros
Верхний штырь для тележек



CODE	ART.	Finitura Finishing	Size	A	B	C	D	M	L	Portata Capacity	Box info	
											Pcs per pack	Kg
10118550 001	377P	Zincato	Piccolo	8	50	17	Ø20	M16	220	400 kg	4	1,6
10118535 001	377G-290	Zincato	Grande	9	60	22	Ø26,5	M20	290	800 kg	4	3,1
10118535 002	377G-290	Tropicalizzato	Grande	9	60	22	Ø26,5	M20	290	800 kg	4	3,1
10118535 003	377G-290	Zincato Nero	Grande	9	60	22	Ø26,5	M20	290	800 kg	4	3,1
10118540 001	377G-330	Zincato	Grande	9	60	22	Ø26,5	M20	330	800 kg	4	3,5
10118540 002	377G-330	Tropicalizzato	Grande	9	60	22	Ø26,5	M20	330	800 kg	4	3,5
10118540 003	377G-330	Zincato Nero	Grande	9	60	22	Ø26,5	M20	330	800 kg	4	3,5

Zincato: Galvanized / Galvanisé / Verzinkt / Galvanizado / Оцинкованная
Tropicalizzato: Yellow Galvanized / Zingué jaune / Gelbverzinkt / Tropicalizado / В тропическом исполнении
Zincato Nero: Black Galvanized / Galvanisé Noir / Verzinkt Schwarz / Galvanizado Negro / Черный оцинкованный

Categoria commerciale: 3E

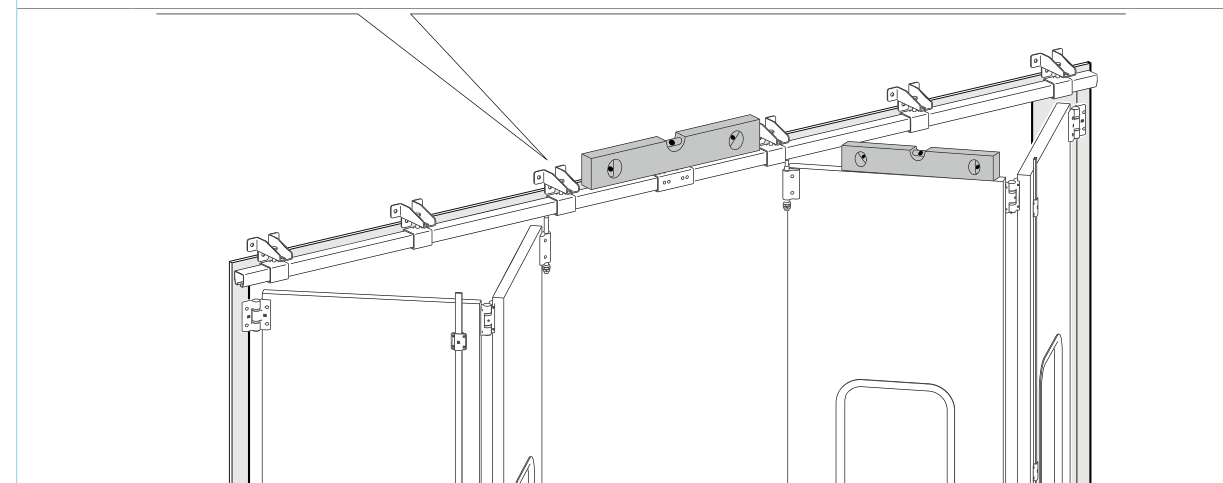
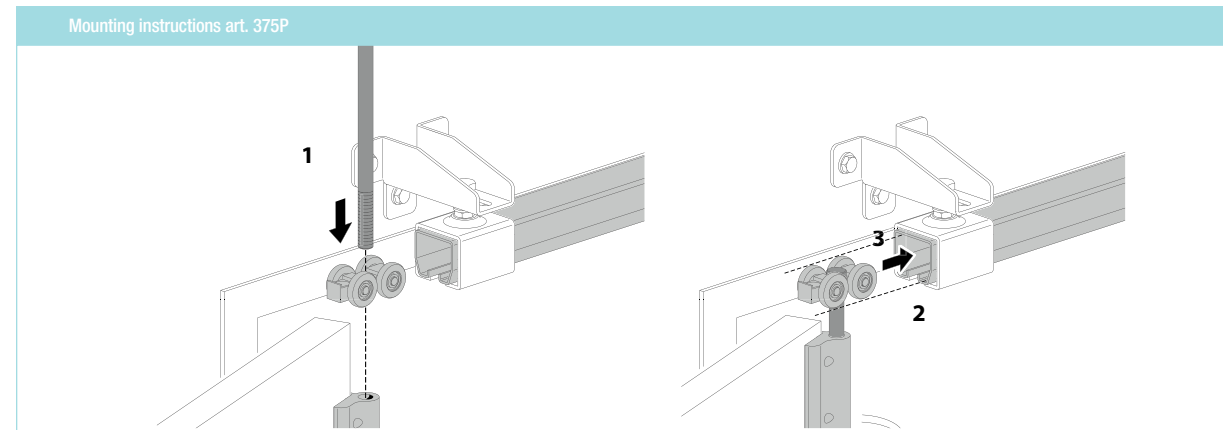
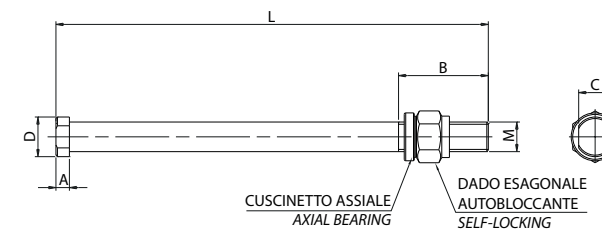



377 R

Perno superiore ribassato
Lowered upper pin
Pivot supérieur surbaissé
Oberer Bolzen herabgesenkt
Perno superior rebajado
Верхний штырь пониженный



CODE	ART.	Finitura Finishing	Portata Capacity	Box info	
				Pcs per pack	Kg
10118530 001	377 R-330	Zincato	400 kg	4	3,6
10118530 002	377 R-330	Tropicalizzato	400 kg	4	3,6
10118530 003	377 R-330	Zincato Nero	400 kg	4	3,6

Zincato: Galvanized / Galvanisé / Verzinkt / Galvanizado / Оцинкованная
Tropicalizzato: Yellow Galvanized / Zingué jaune / Gelbverzinkt / Tropicalizado / В тропическом исполнении
Zincato Nero: Black Galvanized / Galvanisé Noir / Verzinkt Schwarz / Galvanizado Negro / Черный оцинкованный

Categoria commerciale: 3E

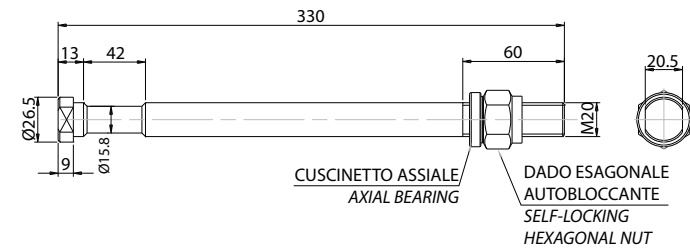

377 G-SC

Perno superiore per scorrevoli zincato
Galvanized upper pin for sliding doors
Pivot supérieur pour portail coulissant zingué
Oberer Bolzen für Schiebetüren verzinkt
Perno superior para puerta corredera galvanizado
Верхний штырь для передвижения оцинкованный



CODE	ART.	Portata Capacity	Box info	
			Pcs per pack	Kg
10118701 001	377 G-SC	400 kg	4	1,4

Finishing: Zincato / Galvanized

Categoria commerciale: 3E

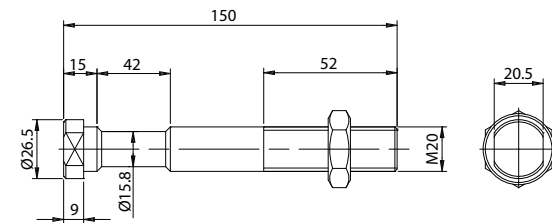

387

Profilo ad "u" per deviatori ad impacco laterale
"U" profile for side folding switches
Profil en "u" pour deviateurs pour portail pliable lateral
U-Profil für Ablenker für seitliche Paket-Lagerung
Perfil en "U" para desviadores para puerta plegable
Профиль в форме "u" для отклоняющего устройства с боковым воздействием



CODE	ART.	Size	Box info	
			Pcs per pack	Kg
10210101 503	387	L=6000	1	9,4

Finishing: RAL 9005 nero / RAL 9005 black

Categoria commerciale: 3G

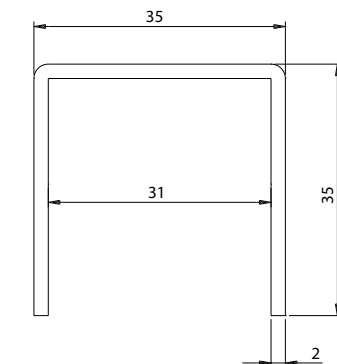

395 DX-SX

Carrello in alluminio pressofuso a 3 ruote
Die-cast aluminium trolley with three wheels
Chariot en aluminium moulé a 3 galets
Rollenapparat aus Alu-druckguss mit 3 Rollen
Carro de aluminio fundido a presión con 3 ruedas
Тележка из литого алюминия с 3 колесами



CODE	ART.	Portata Capacity	Box info	
			Pcs per pack	Kg
10118350 503	395 DX	*	4	2,3
10118360 503	395 SX	*	4	2,3

Finishing: RAL 9005 nero / RAL 9005 black

Categoria commerciale: 3B

*Il carrello non ha funzione di portata ma solo di guida / *The trolley has no load-bearing function; it only serve to drive the door.

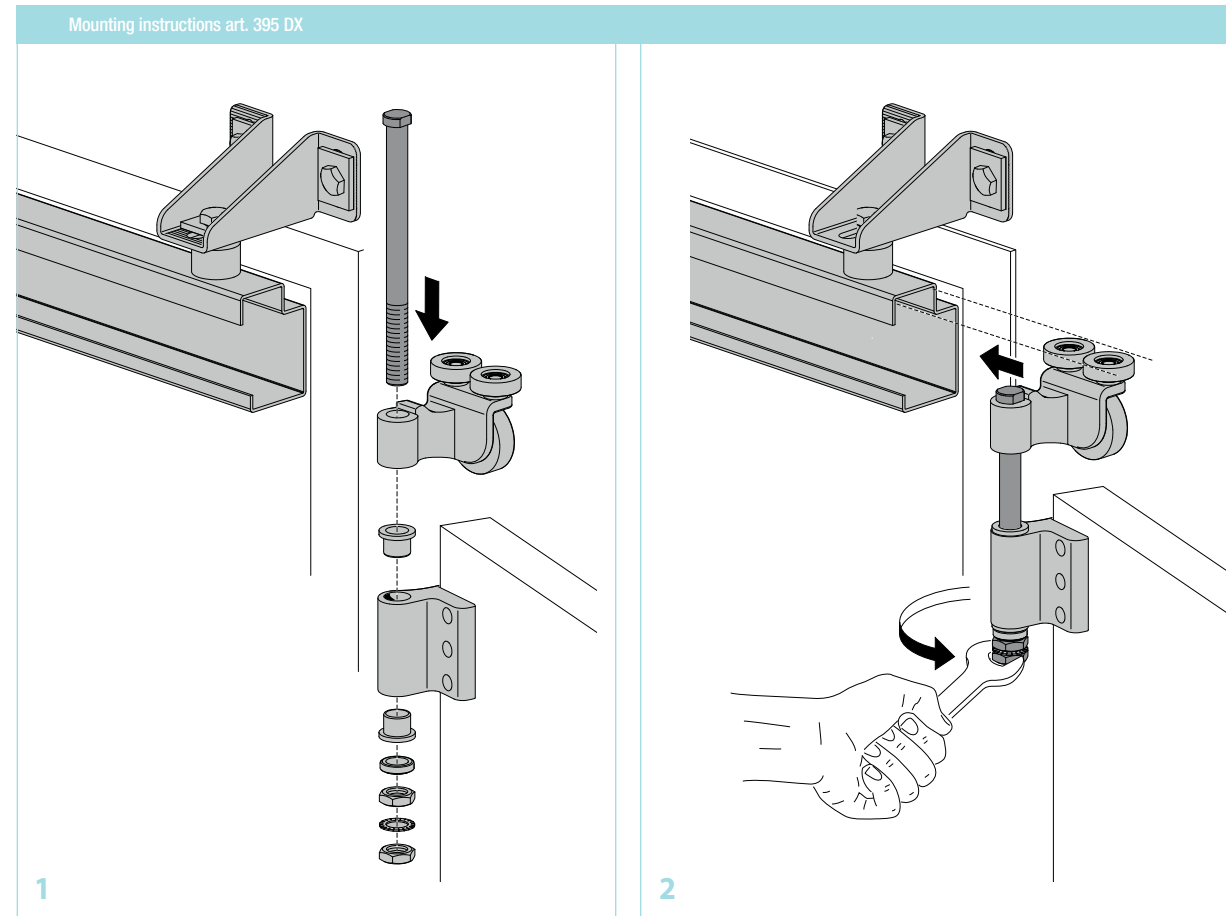
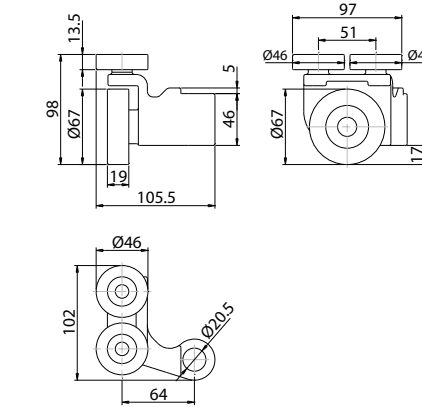



396

Carrello reversibile in alluminio a 3 ruote

Reversible aluminium trolley with three wheels
Chariot réversible en aluminium à 3 galets
Reversibler Rollenapparat aus Aluminium mit 3 Rollen
Carro reversible de aluminio con 3 ruedas
Реверсивная тележка из алюминия с 3 колесами



CODE	ART.	Portata Capacity	Box info	
			Pcs per pack	Kg
10118305 503	396	280 kg	4	3,6

Finishing: RAL 9005 nero / RAL 9005 black

Categoria commerciale: 3B

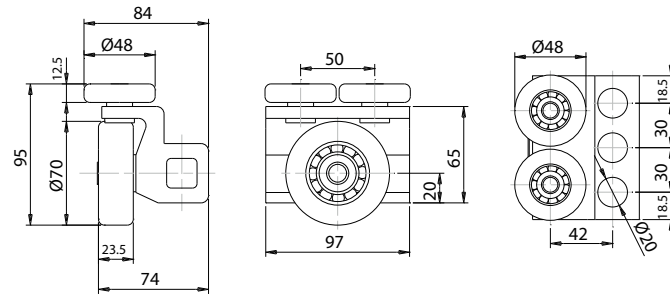

398

Monorotaia superiore per carrelli 4 ruote grande zincata

Large galvanized upper guide for trolleys with four wheels
Rail supérieur pour chariots 4 galets grands zingues
Obere Laufschiene für Rollenapparate mit 4 Rollen gross verzinkt
Monocarril superior grande galvanizado para carros con 4 ruedas
Верхний монорельс для тележек с 4 колесами большой оцинкованный

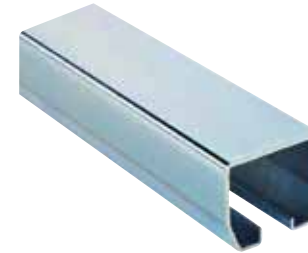

CODE	ART.	Size	Box info	
			Pcs per pack	Kg
10203011 001	398-3000	L=3000	1	30,4
10203012 001	398-6000	L=6000	1	60,7

Finishing: Zincato / Galvanized

Categoria commerciale: 3G

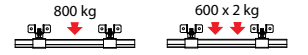
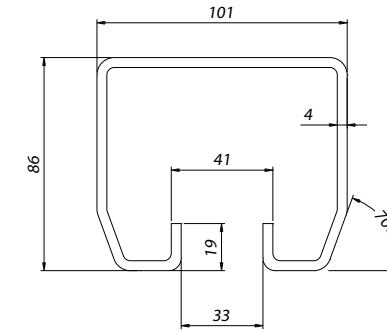

Mounting instructions art. 396

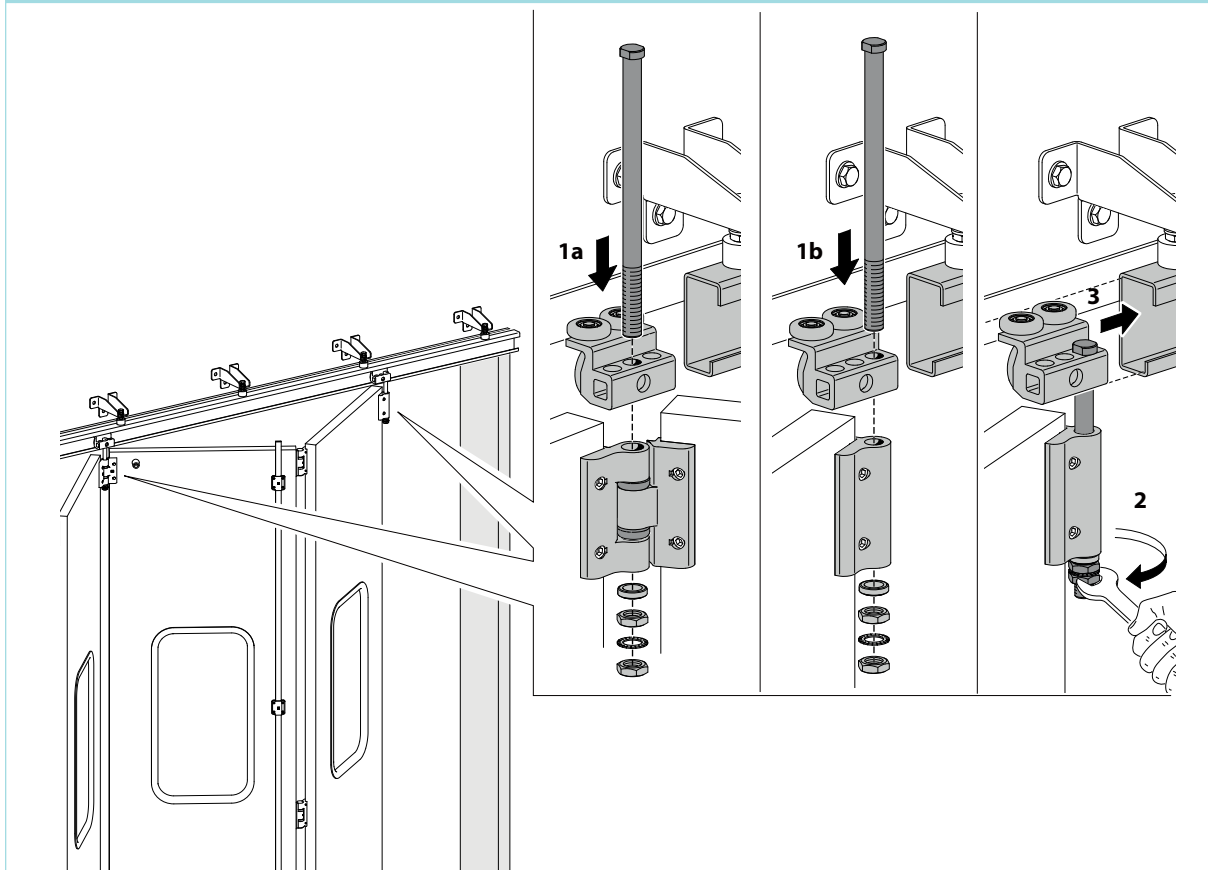

399

Monorotaia superiore per carrelli 4 ruote piccola zincata

Small galvanized upper guide for trolleys with four wheels
Rail supérieur pour chariots 4 galets petite zingues
Obere Laufschiene für Rollenapparate mit 4 Rollen klein verzinkt
Monocarril superior pequeño galvanizado para carros con 4 ruedas
Верхний монорельс для тележек с 4 колесами малый оцинкованный

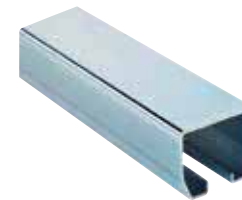

CODE	ART.	Pcs per pack	Box info	
			Kg	
10203006 001	399-3000	1	16,7	
10203008 001	399-5500	1	30,4	
10203007 001	399-6000	1	33,3	

Finishing: Zincato / Galvanized

Categoria commerciale: 3G

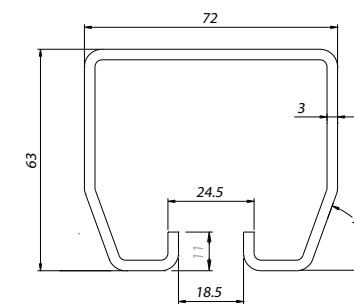



671

Maniglione curvo Ø15 mm
Bended pull handle dia. 15mm
Poignée courbée dia. 15mm
Gebogener Stossgriff Durchm. 15 mm
Tirador curvo Ø 15 mm
Изогнутая ручка Ø15 мм



CODE	ART.	Size	I	L	Box info	
					Pcs per pack	Kg
11000400 503	671P	Piccolo	165	215	10	6,4
11000401 503	671G	Grande	215	265	10	7,1

Finishing: RAL 9005 nero / RAL 9005 black

Categoria commerciale: 1H

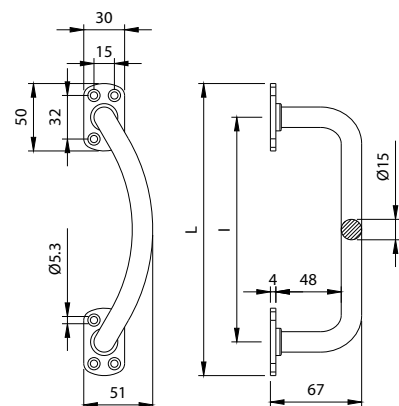

674

Maniglia di trascinamento in zama
presso fusa
Die-cast alloy handle
Béquille en zamac moulée sous pression
Torgriff aus Druckguss-Zamak
Tirador de zamak fundido a presión
Ручка из литого сплава зاما



CODE	ART.	Size	I	L	Box info	
					Pcs per pack	Kg
10905006 503	674				20	4,2

Finishing: RAL 9005 nero / RAL 9005 black

Categoria commerciale: 1H

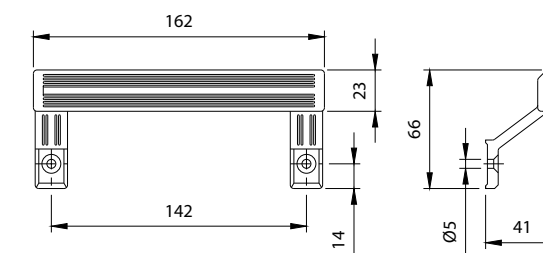

672

Maniglione curvo tubolare
Bended pull handle
Poignée courbée
Gebogener rohrförmiger Stossgriff
Tirador curvado tubular
Изогнутая ручка трубчатая



CODE	ART.	Size	A	B	C	D	E	F	G	H	I	L	M	S	Box info	
															Pcs per pack	Kg
11000300 503	672P	Piccolo	35	54	20	20	35	Ø5,3	47	67	180	234	48	3,5	10	4,6
11000301 503	672G	Grande	45	71	27	25	47	Ø6,3	60	85	280	351	71	4	10	9,3

Finishing: RAL 9005 nero / RAL 9005 black

Categoria commerciale: 1H

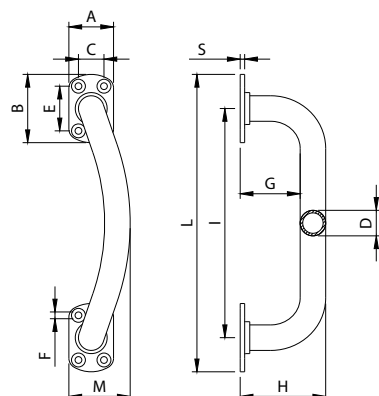

675

Maniglione zancato Ø15 mm
Bended pull handle dia. 15mm
Poignée courbée dia. 15mm
Gebogener Stossgriff Durchm. 15 mm
Tirador curvado Ø 15 mm
Ручка гнутая Ø 15 мм



CODE	ART.	Size	I	L	Box info	
					Pcs per pack	Kg
11000505 503	675P	Piccolo	165	215	10	6,5
11000510 503	675G	Grande	215	265	10	6,5

Finishing: RAL 9005 nero / RAL 9005 black

Categoria commerciale: 1H

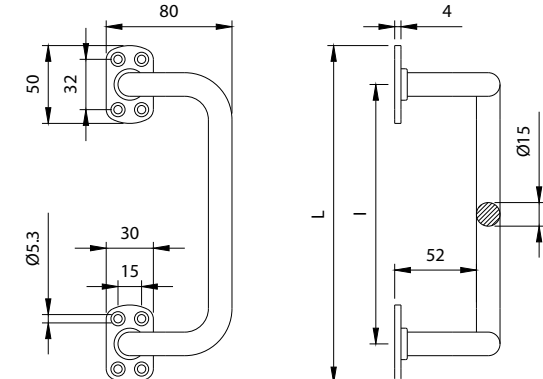

673

Catenaccio a saldare
Bolt to be welded
Verrou à souder
Stossriegel zum Anschweißen
Pasador para soldar
Привариваемая цепь



CODE	ART.	Size	Box info	
			Pcs per pack	Kg
11900505 001	673		25	4,2

Finishing: Zincato / Galvanized

Categoria commerciale: 1D

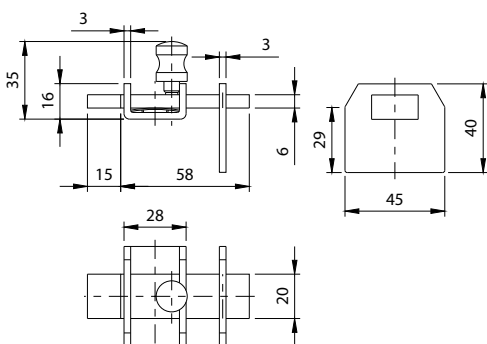

677

Maniglione diritto Ø15 mm
Straight pull handle dia. 15mm
Poignée droite dia. 15mm
Gerader Stossgriff Durchm. 15mm
Tirador recto Ø 15 mm
Ручка прямая Ø 15 мм



CODE	ART.	Size	I	L	Box info	
					Pcs per pack	Kg
11001005 503	677P	Piccolo	165	215	10	4,5
11001010 503	677G	Grande	215	265	10	5,4

Finishing: RAL 9005 nero / RAL 9005 black

Categoria commerciale: 1H

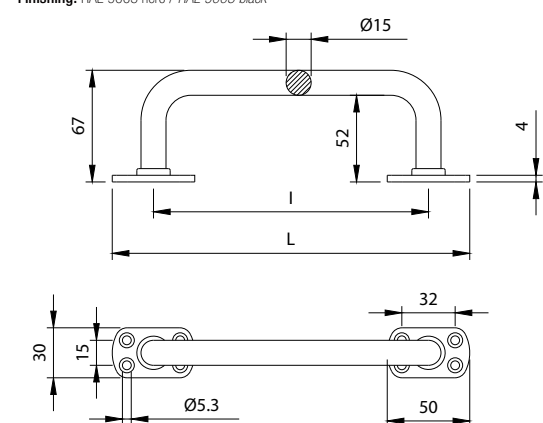



678

Maniglione tubolare zancato
Bended pull handle
Poignée courbée
Gebogener rohrförmiger Stossgriff
Tirador tubular curvado
Ручка трубчатая гнутая



CODE	ART.	Size	A	B	C	D	E	F	G	H	I	L	M	S	Box info	
															Pcs per pack	Kg
11001505 503	678P	Piccolo	35	54	20	Ø20	35	Ø5,3	43	67	180	234	100	3,5	10	4,2
11001510 503	678G	Grande	45	71	27	Ø25	47	Ø6,3	53	85	280	351	143	4	10	9,0

Finishing: RAL 9005 nero / RAL 9005 black

Categoria commerciale: 1H

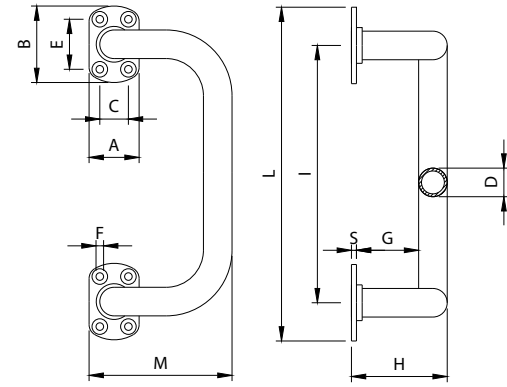

679

Maniglione tubolare diritto
Straight pull handle
Poignée droite
Rohrförmiger gerader Stossgriff
Tirador tubular recto
Ручка трубчатая прямая



CODE	ART.	Size	A	B	C	D	E	F	G	H	I	L	S	Box info	
														Pcs per pack	Kg
11002505 503	679P	Piccolo	35	54	20	Ø20	35	Ø5,3	43	67	180	234	3,5	10	3,2
11002510 503	679G	Grande	45	71	27	Ø25	47	Ø6,3	53	85	280	351	4	10	6,7

Finishing: RAL 9005 nero / RAL 9005 black

Categoria commerciale: 1H

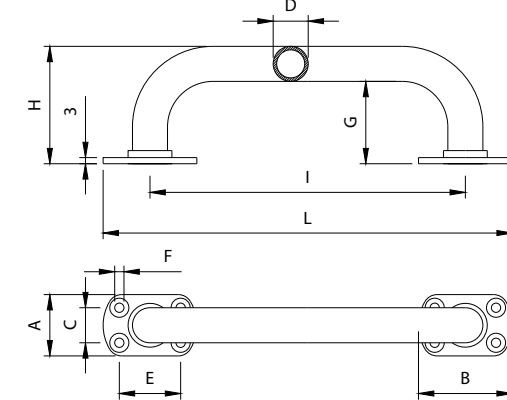

679i

Maniglione tubolare diritto in acciaio inox aisi 316i
Straight s/s aisi 316i pull handle
Poignée droite en acier inox aisi 316i
Gerader Rohrförmiger Stossgriff aus Edelstahl aisi 316i
Tirador tubular recto de acero inox. AISI 316i
Ручка трубчатая прямая нержавеющая сталь aisi 316i



CODE	ART.	A	B	C	D	E	F	H	I	L	Box info	
											Pcs per pack	Kg
11002610	679i	45	71	27	Ø30	47,3	Ø6,3	85	280	351	1	0,7

Finishing: Inox / Stainless steel

Categoria commerciale: 2H

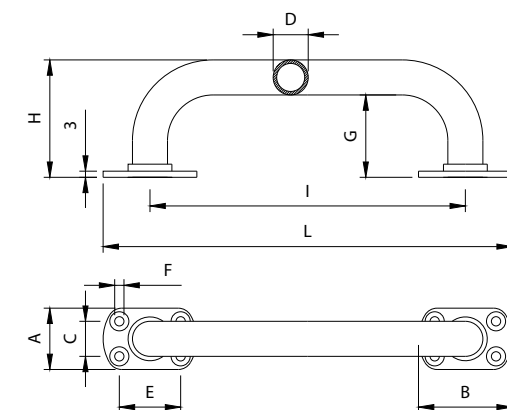

680

Cariglione "Car" aste esterne 14x14 mm
"Car" lever bolt internal bars 14x14mm
Crémone à levier "Car" tringles intérieures 14x14mm
Treibriegel "Car" Innenstange 14x14mm
Falleba "Car" varillas externas 14x14 mm
Болтовой рычаг "Car" наружные штыри 14x14 мм

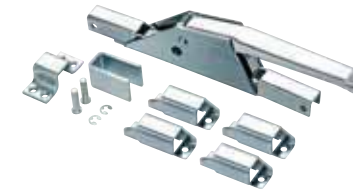

CODE	ART.	Pcs per pack	Box info	
			Pcs per pack	Kg
11203005 001	680	5	5	4,5

Finishing: Zincato / Galvanized

Categoria commerciale: 1B

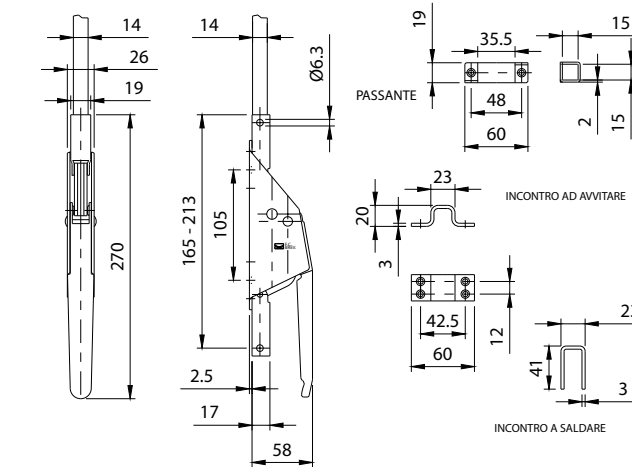

Mounting instructions art. 680

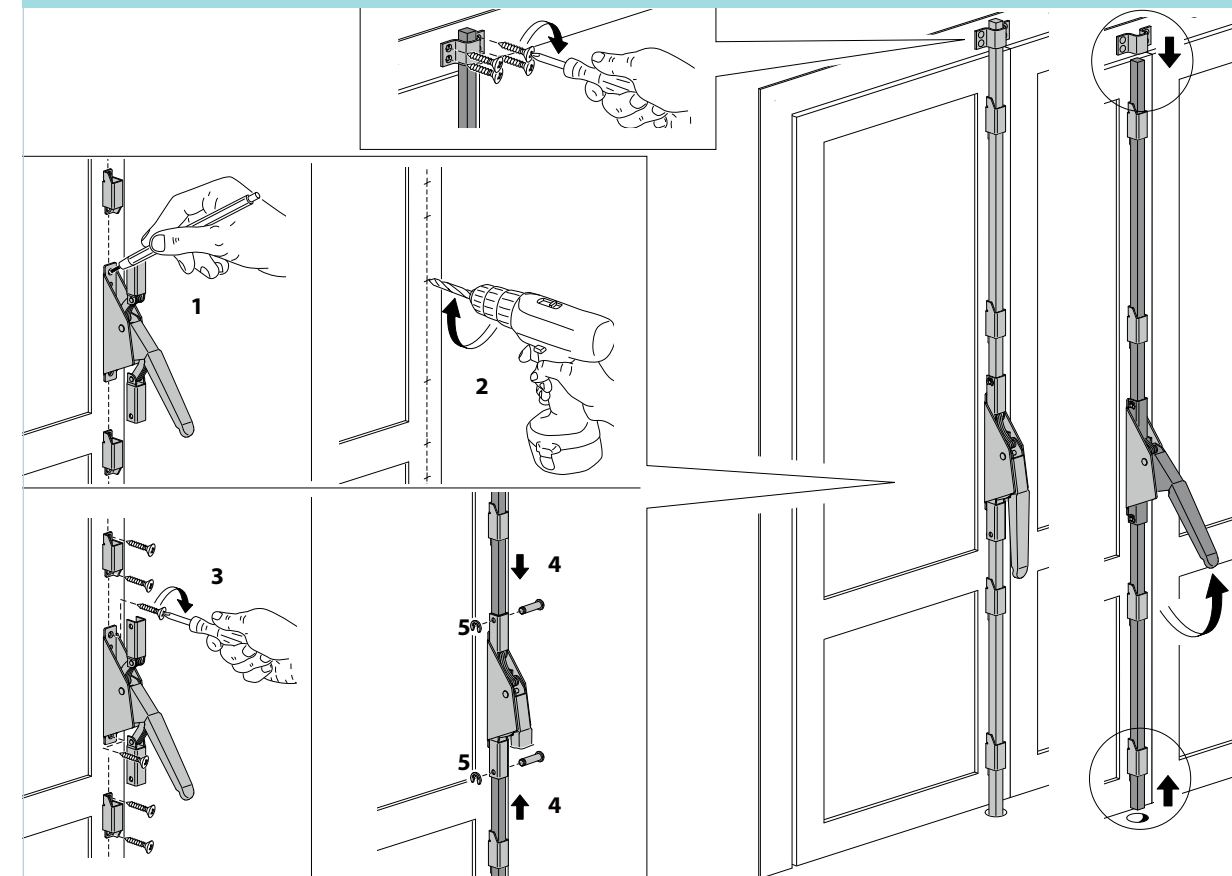



682

Cariglione "Car" con cilindro aste esterne 14x14 mm

"Car" lever bolt external bars 14x14mm
Crémone à levier "Car" tringles extérieures 14x14mm
Treibriegel "Car" mit Zylinder und Außenstangen 14x14 mm
Falleba "Car" con cilindro varillas externas 14x14 mm
Болтовой рычаг "Car" с цилиндром наружные штыри 14x14 мм

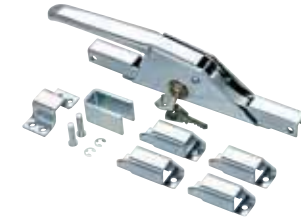

CODE	ART.	Box info	
		Pcs per pack	Kg
11203505 001	682	5	5,0

Finishing: Zincato / Galvanized

Categoria commerciale: 1B

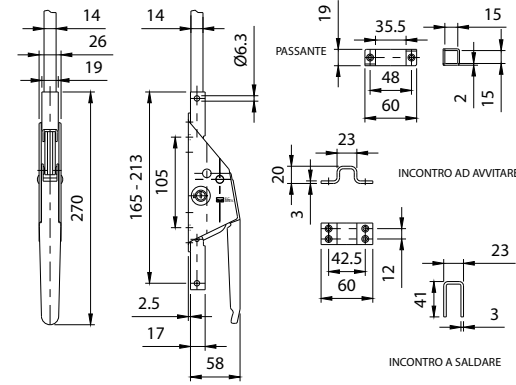

685

Cariglione per aste interne Ø6 mm

Lever bolt internal bars dia.6mm
Crémone à levier tringles intérieures dia 6mm
Treibriegel für Innenstange Durchm. 6mm
Falleba para varillas internas Ø6 mm
Болтовой рычаг для внутренних штырей Ø6 мм



CODE	ART.	Box info	
		Pcs per pack	Kg
11204805 503	685	10	5,0

Finishing: RAL 9005 nero / RAL 9005 black

Categoria commerciale: 1B

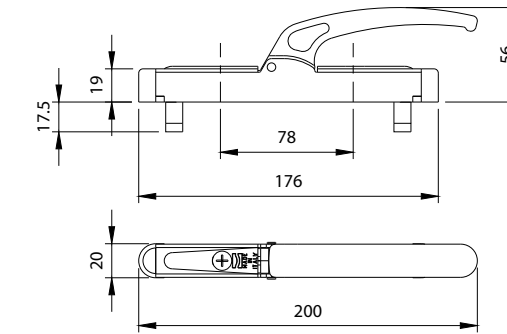

683

Asta per cariglione art. 686 10x10 mm

Bar for lever bolt art.686 10x10mm
Tringle pour crémone art.686 10x10mm
Stange für Treibriegel art.686 10x10mm
Varilla para falleba art. 686 10x10 mm
Стержень для болтового рычага art.686 10x10 мм



CODE	ART.	Size	L	Box info	
				Pcs per pack	Kg
10205505 001	683	L=1500	1500	1	1,2
10205510 001	683	L=2000	2000	1	1,6

Finishing: Zincato / Galvanized

Categoria commerciale: 1B

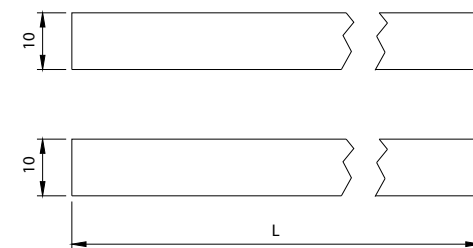

686

Cariglione per aste esterne 10x10 mm

Lever bolt for external bars 10x10mm
Crémone à levier pour tringles extérieures 10x10mm
Treibriegel für Außenstange Durchm. 10x10mm
Falleba para varillas externas 10x10 mm
Болтовой рычаг для наружных штырей 10x10 мм



CODE	ART.	Box info	
		Pcs per pack	Kg
11204705 503	686	10	5,0

Finishing: RAL 9005 nero / RAL 9005 black

Categoria commerciale: 1B

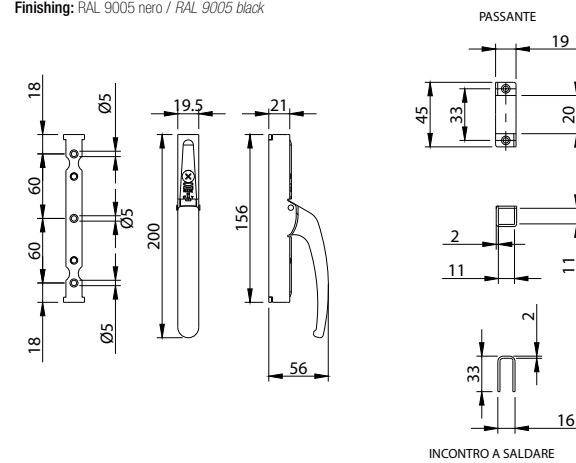

684

Cariglione "Bon" con cilindro

"Bon" lever bolt with cylinder
Crémone à levier "Bon" avec cylindre
Treibriegel "Bon" mit Zylinder
Falleba "Bon" con cilindro
Болтовой рычаг "Bon" с цилиндром



CODE	ART.	Box info	
		Pcs per pack	Kg
11204005 700	684	5	3,6

Finishing: Zincato / Galvanized

Categoria commerciale: 1B

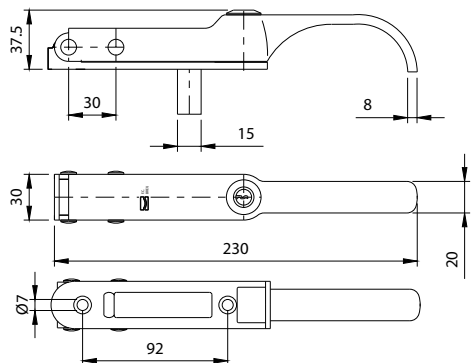

687

Asta forata 14x14 mm per cariglione art. 680 - 682

Holed bar 14x14 mm for lever bolt art.680-682
Tringle percée 14x14mm pour crémone art.680-682
Stange mit Bohrungen 14x14mm für Treibriegel art.680-682
Varilla perforada 14x14 mm para falleba arts. 680-682
Стержень с отверстиями 14x14 мм для болтового рычага art.680-682



CODE	ART.	Size	L	Box info	
				Pcs per pack	Kg
10206005 001	687	L=1500	1500	1	2,3
10206010 001	687	L=2000	2000	1	3,1

Finishing: Zincato / Galvanized

Categoria commerciale: 1B

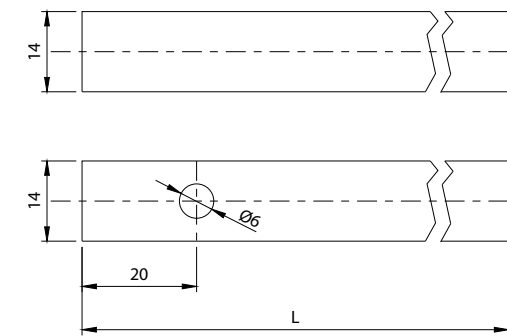



690 MC

Cariglione star piccolo
Small star lever bolt
Cremona star petite
Treibriegel star klein
Falleba star pequena
Малый болтовой рычаг star



CODE	ART.	Size	Finitura Finishing	Corsa Rod stroke	Box info	
					Pcs per pack	Kg
11205006 001	690 MC	DX	Zincato	31	2	1,9
11205006 503	690 MC	DX	RAL 9005	31	2	1,9
11205011 001	690 MC	SX	Zincato	31	2	1,8
11205011 503	690 MC	SX	RAL 9005	31	2	1,8

Zincato: Galvanized / Galvanisé / Verzinkt / Galvanizado / Оцинкованная
RAL 9005: nero / black / noir / Schwarz / negro / черный

Categoria commerciale: 3A

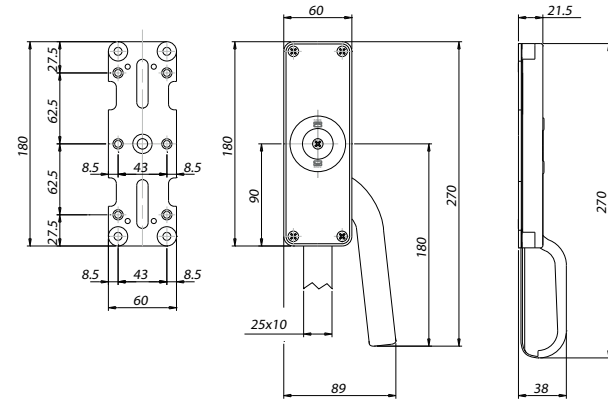

691 P

Passante per aste 25x10

Rod guide 25x10
Traversant pour tringles 25x10
Lasche für Stangen 25x10
Puente para varillas 25x10
Сквозная направляющая для стержней 25x10



CODE	ART.	Size	Finitura Finishing	Box info	
				Pcs per pack	Kg
12001105 001	691 P	25x10	Zincato	50	2,7
12001105 503	691 P	25x10	RAL 9005	50	2,8

Zincato: Galvanized / Galvanisé / Verzinkt / Galvanizado / Оцинкованная
RAL 9005: nero / black / noir / Schwarz / negro / черный

Categoria commerciale: 3A

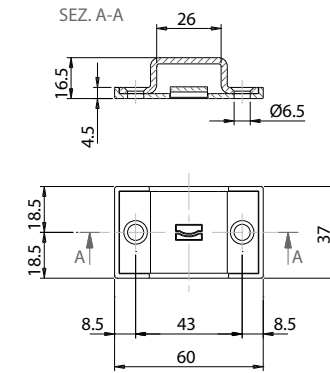

Mounting instructions art. 690 MC

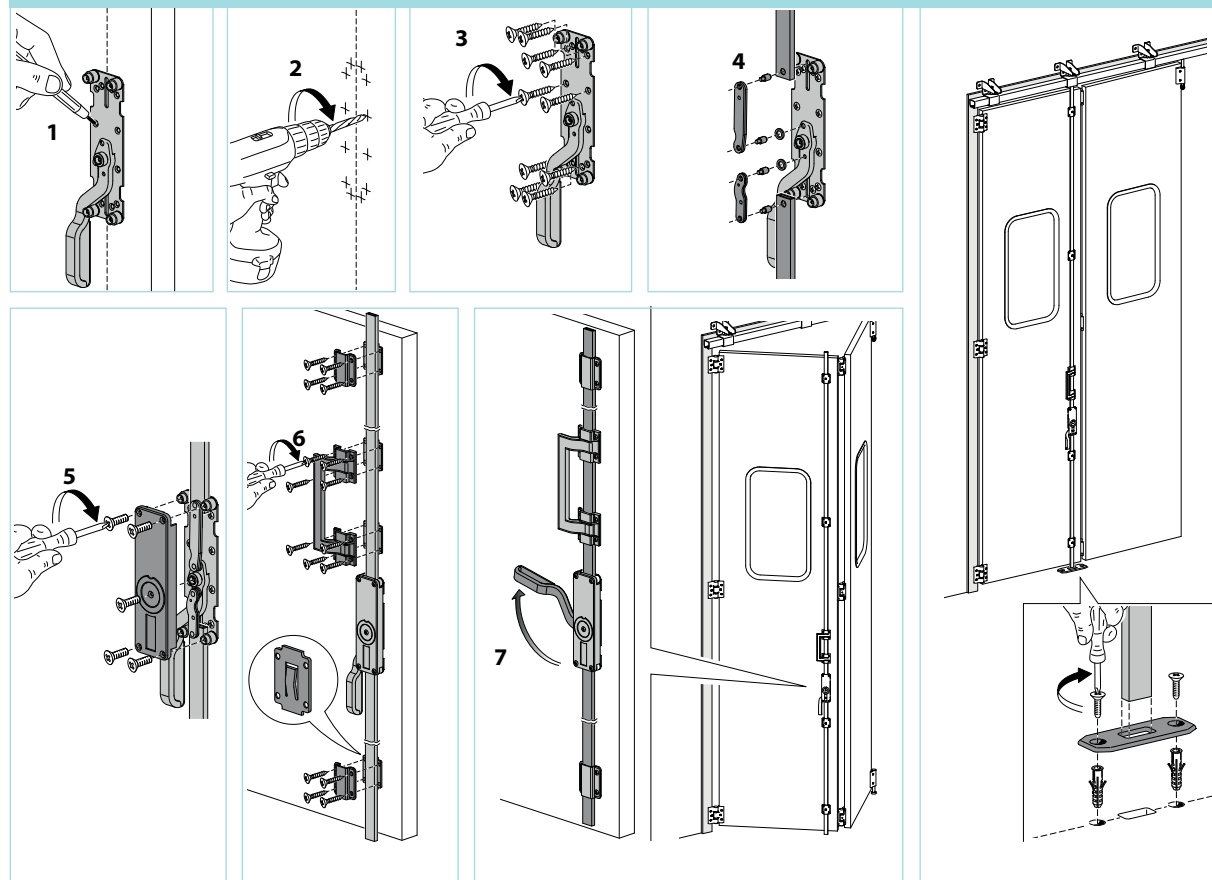

691 G

Passante per asta 30x10

Rod guide for 30 x 10 rod
Traversant pour tringle 30x10
Führungsaufnahme für Verbindungsstange 30x10
Puente para varilla 30x10
Сквозная направляющая для стержней 30x10



CODE	ART.	Size	Finitura Finishing	Box info	
				Pcs per pack	Kg
12001505 001	691 G	30x10	Zincato	50	7,1
12001505 503	691 G	30x10	RAL 9005	50	7,1

Zincato: Galvanized / Galvanisé / Verzinkt / Galvanizado / Оцинкованная
RAL 9005: nero / black / noir / Schwarz / negro / черный

Categoria commerciale: 3A

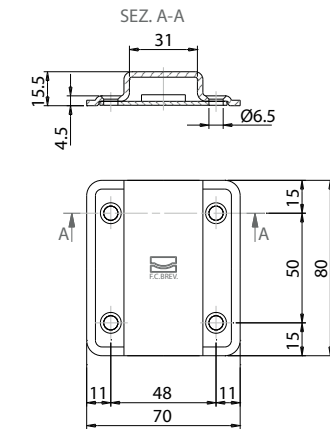



692 P

Asta di collegamento 25x10
Connection rod 25x10
Tringle de jonction 25x10
Verbindungsstange 25x10
Varilla de conexión 25x10
Соединительный стержень 25x10



CODE	ART.	Size	Finitura Finishing	L	Box info	
					Pcs per pack	Kg
10203503 001	692 P	1,2 mt	Zincato	1200	1	2,3
10203503 003	692 P	1,2 mt	Zincato Nero	1200	1	2,3
10203515 001	692 P	3,0 mt	Zincato	3000	1	5,9
10203515 003	692 P	3,0 mt	Zincato Nero	3000	1	5,9
10203504 001	692 P	4,8 mt	Zincato	4800	1	9,5
10203504 003	692 P	4,8 mt	Zincato Nero	4800	1	9,5

Zincato: Galvanized / Galvanisé / Verzinkt / Galvanizado / Оцинкованная
Zincato Nero: Black Galvanized / Galvanisé Noir / Verzinkt Schwarz / Galvanizado negro / Оцинкованная черный

Categoria commerciale: 3A

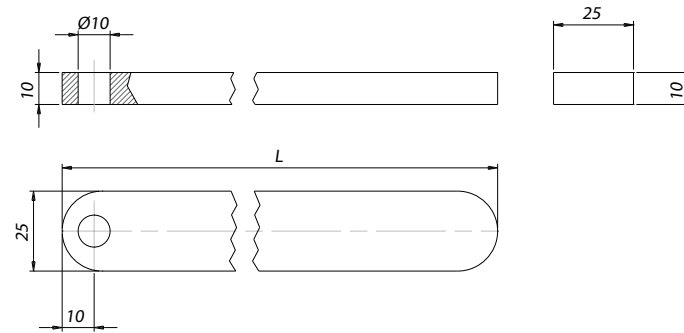

693 MC

Cariglione star piccolo per aste interne
Small star lever bolt for internal rods
Crémone star petite pour tringles intérieures
Treibriegel star klein für innenstangen
Falleba star pequeña para varillas internas
Малый болтовой рычаг star для внутренних стержней



CODE	ART.	Size	Corsa Rod stroke	Box info	
				Pcs per pack	Kg
11207006 503	693 MC	DX	31	2	2,5
11207011 503	693 MC	SX	31	2	2,5

Finishing: RAL 9005 nero / RAL 9005 black

Categoria commerciale: 3A

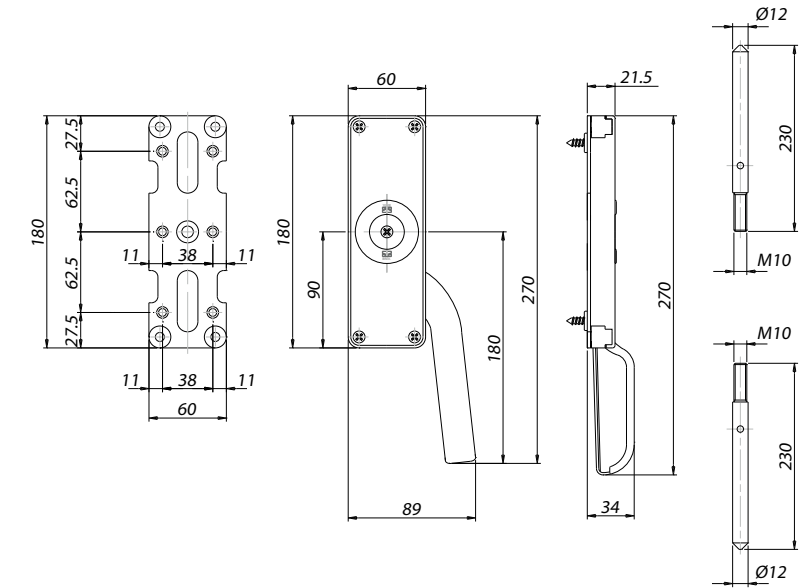

692 G

Asta di collegamento 30x10
Connection rod 30x10
Tringle de jonction 30x10
Verbindungsstange 30x10
Varilla de conexión 30x10
Соединительный стержень 30x10



CODE	ART.	Size	Finitura Finishing	L	Box info	
					Pcs per pack	Kg
10203518 001	692 G	1,2 mt	Zincato	1200	1	2,8
10203518 003	692 G	1,2 mt	Zincato Nero	1200	1	2,8
10203530 001	692 G	3,0 mt	Zincato	3000	1	7,0
10203530 003	692 G	3,0 mt	Zincato Nero	3000	1	7,0
10203540 001	692 G	4,8 mt	Zincato	4800	1	11,3
10203540 003	692 G	4,8 mt	Zincato Nero	4800	1	11,3

Zincato: Galvanized / Galvanisé / Verzinkt / Galvanizado / Оцинкованная
Zincato Nero: Black Galvanized / Galvanisé Noir / Verzinkt Schwarz / Galvanizado negro / Оцинкованная черный

Categoria commerciale: 3A

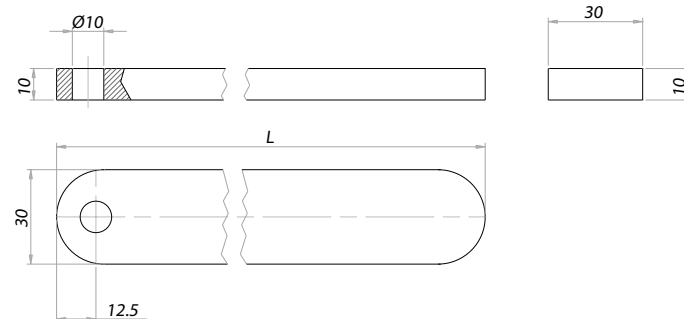

694 MC

Cariglione star grande
Large star lever bolt
Crémone star grande
Treibriegel star gross
Falleba star grande
Большой болтовой рычаг star



CODE	ART.	Finitura Finishing	Corsa Rod stroke	Box info	
				Pcs per pack	Kg
11205506 001	694 MC	Zincato	40	2	3,8
11205506 503	694 MC	RAL 9005	40	2	3,8
11205511 001	694 MC	Zincato	40	2	3,8
11205511 503	694 MC	RAL 9005	40	2	3,8

Zincato: Galvanized / Galvanisé / Verzinkt / Galvanizado / Оцинкованная
RAL 9005: nero / black / noir / Schwarz / negro / черный

Categoria commerciale: 3A

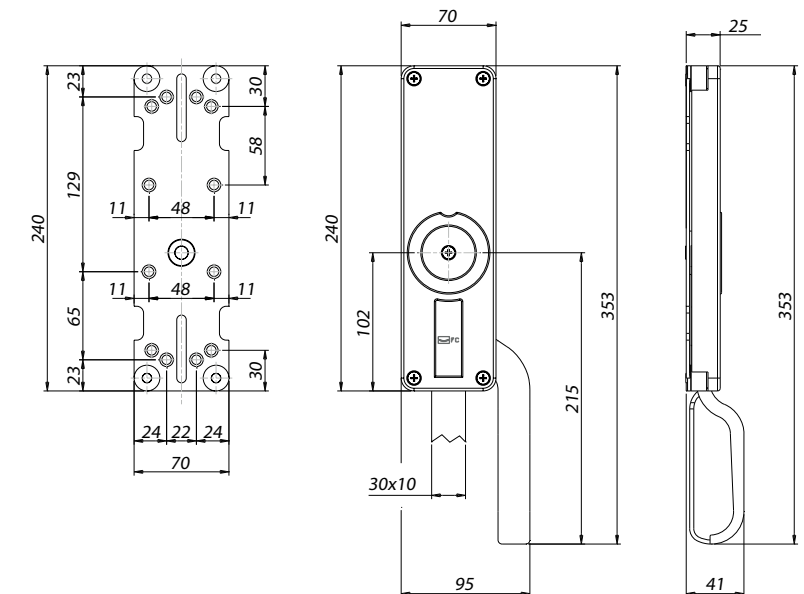



695 P

Asta di collegamento tubolare 25x10
Connection tubular rod 25x10
Tringle de jonction tubulaire 25x10
Rohr-Verbindungsstange 25x10
Varilla de conexión tubular 25x10
Соединительный стержень трубчатый 25x10



CODE	ART.	Size	Finitura Finishing	L	Box info	
					Pcs per pack	Kg
10203703 001	695 P	1,2 mt	Zincato	1200	1	1,2
10203703 003	695 P	1,2 mt	Zincato Nero	1200	1	1,2
10203715 001	695 P	3,0 mt	Zincato	3000	1	2,9
10203715 003	695 P	3,0 mt	Zincato Nero	3000	1	2,9
10203704 001	695 P	4,8 mt	Zincato	4800	1	4,7
10203704 003	695 P	4,8 mt	Zincato Nero	4800	1	4,7

Zincato: Galvanized / Galvanisé / Verzinkt / Galvanizado / Оцинкованная
Zincato Nero: Black Galvanized / Galvanisé Noir / Verzinkt Schwarz / Galvanizado negro / Оцинкованная черный

Categoria commerciale: 3A

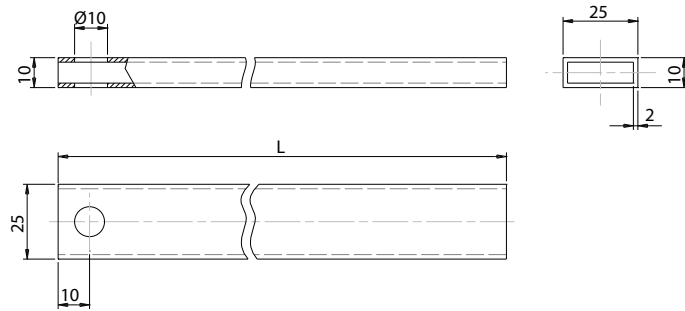

695 G

Asta di collegamento tubolare 30x10
Connection tubular rod 30x10
Tringle de jonction tubulaire 30x10
Rohr-Verbindungsstange 30x10
Varilla de conexión tubular 30x10
Соединительный стержень трубчатый 30x10



CODE	ART.	Size	Finitura Finishing	L	Box info	
					Pcs per pack	Kg
10203718 001	695 G	1,2 mt	Zincato	1200	1	1,2
10203718 003	695 G	1,2 mt	Zincato Nero	1200	1	1,2
10203730 001	695 G	3,0 mt	Zincato	3000	1	3,4
10203730 003	695 G	3,0 mt	Zincato Nero	3000	1	3,4
10203740 001	695 G	4,8 mt	Zincato	4800	1	5,4
10203740 003	695 G	4,8 mt	Zincato Nero	4800	1	5,4

Zincato: Galvanized / Galvanisé / Verzinkt / Galvanizado / Оцинкованная
Zincato Nero: Black Galvanized / Galvanisé Noir / Verzinkt Schwarz / Galvanizado negro / Оцинкованная черный

Categoria commerciale: 3A

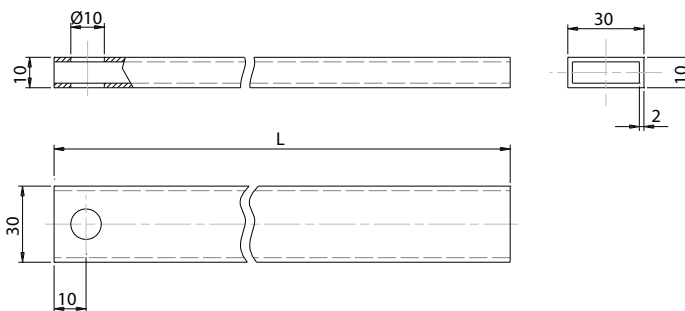

695 PM

Asta di chiusura tubolare con maniglia 25x10
Closing tubular rod with handle 25x10
Tringle tubulaire de fermeture avec poignée 25x10
Rohrverschlussstange mit Griffe 25x10
Varilla de cierre tubular con manilla 25x10
Закрывающий стержень трубчатый с ручкой 25x10



CODE	ART.	Size	Finitura Finishing	L	Box info	
					Pcs per pack	Kg
10203702 001	695 PM	1,2 mt	Zincato	1200	1	1,2
10203702 003	695 PM	1,2 mt	Zincato Nero	1200	1	1,2

Zincato: Galvanized / Galvanisé / Verzinkt / Galvanizado / Оцинкованная
Zincato Nero: Black Galvanized / Galvanisé Noir / Verzinkt Schwarz / Galvanizado negro / Оцинкованная черный

Categoria commerciale: 3A

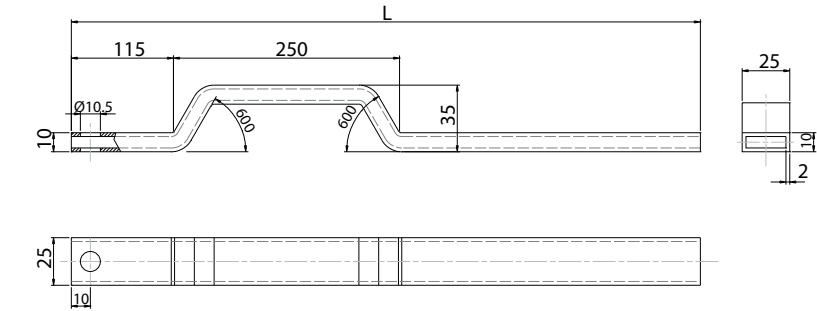

695 GM

Asta di chiusura tubolare con maniglia 30x10
Closing tubular rod with handle 30x10
Tringle tubulaire de fermeture avec poignée 30x10
Rohrverschlussstange mit Griffe 30x10
Varilla de cierre tubular con manilla 30x10
Закрывающий стержень трубчатый с ручкой 30x10



CODE	ART.	Size	Finitura Finishing	L	Box info	
					Pcs per pack	Kg
10203701 001	695 GM	1,2 mt	Zincato	1200	1	1,4
10203701 003	695 GM	1,2 mt	Zincato Nero	1200	1	1,4

Zincato: Galvanized / Galvanisé / Verzinkt / Galvanizado / Оцинкованная
Zincato Nero: Black Galvanized / Galvanisé Noir / Verzinkt Schwarz / Galvanizado negro / Оцинкованная черный

Categoria commerciale: 3A

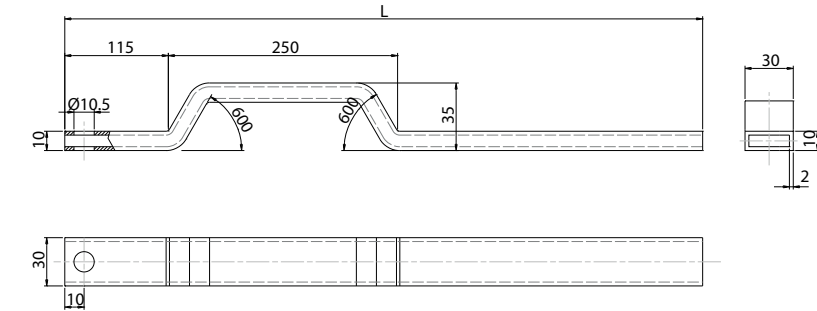

699

Maniglione di trascinamento in nylon con passanti
Nylon pull handle with guides
Poignée d'entraînement en nylon avec traversants
Nylongriff zum Ziehen mit Laschen
Tirador de arrastramiento en nylon con puentes
Тележка с 2 поворотными колесами с подшипниками



CODE	ART.	Box info	
		Pcs per pack	Kg
11003500	699	10	3,0

Finishing: nylon nero / nylon black

Categoria commerciale: 3F

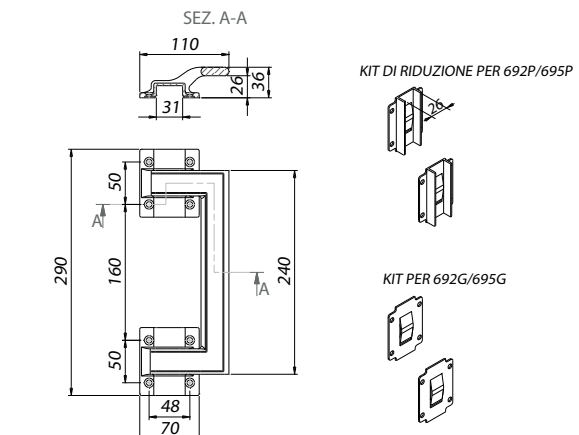



696 MC

Cariglione star grande predisposto per cilindro

Large star lever bolt for cylinder
Crémone star grande pour cylindre
Treibriegel star gross für Zylinder
Falleba star grande para cilindro
Большой болтовой рычаг star для цилиндра



CODE	ART.	Size	Finitura Finishing	Corsa Rod stroke	Box info	
					Pcs per pack	Kg
11206006 001	696 MC	DX	Zincato	40	2	3,0
11206006 503	696 MC	DX	RAL 9005	40	2	3,0
11206011 001	696 MC	SX	Zincato	40	2	3,0
11206011 503	696 MC	SX	RAL 9005	40	2	3,0

Zincato: Galvanized / Galvanisé / Verzinkt
RAL 9005: nero / black / noir / Schwarz

Categoria commerciale: 3A

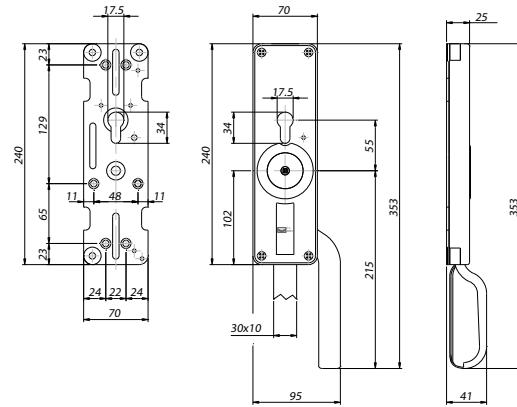

698 MC

Cariglione star grande con maniglia esterna

Large star lever bolt with external handle
Crémone star grande avec béquille extérieure
Treibriegel star gross
Falleba star grande con manilla exterior
Большой болтовой рычаг star с наружной ручкой

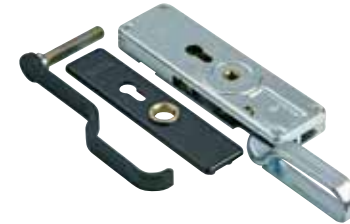

CODE	ART.	Size	L	Finitura Finishing	Corsa Rod stroke	Box info	
						Pcs per pack	Kg
11206506 001	698 MC	DX	50	Zincato	40	2	4,3
11206506 503	698 MC	DX	50	RAL 9005	40	2	4,3
11206511 001	698 MC	SX	50	Zincato	40	2	4,3
11206511 503	698 MC	SX	50	RAL 9005	40	2	4,3
11206526 001	698 MC	DX	80	Zincato	40	2	4,4
11206526 503	698 MC	DX	80	RAL 9005	40	2	4,4
11206531 001	698 MC	SX	80	Zincato	40	2	4,4
11206531 503	698 MC	SX	80	RAL 9005	40	2	4,4

Zincato: Galvanized / Galvanisé / Verzinkt
RAL 9005: nero / black / noir / Schwarz

Categoria commerciale: 3A

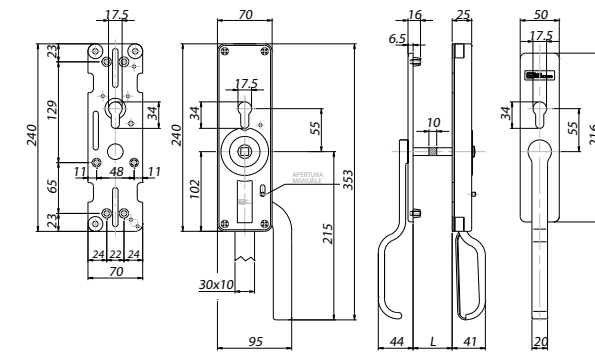

Mounting instructions art. 696 MC - SX

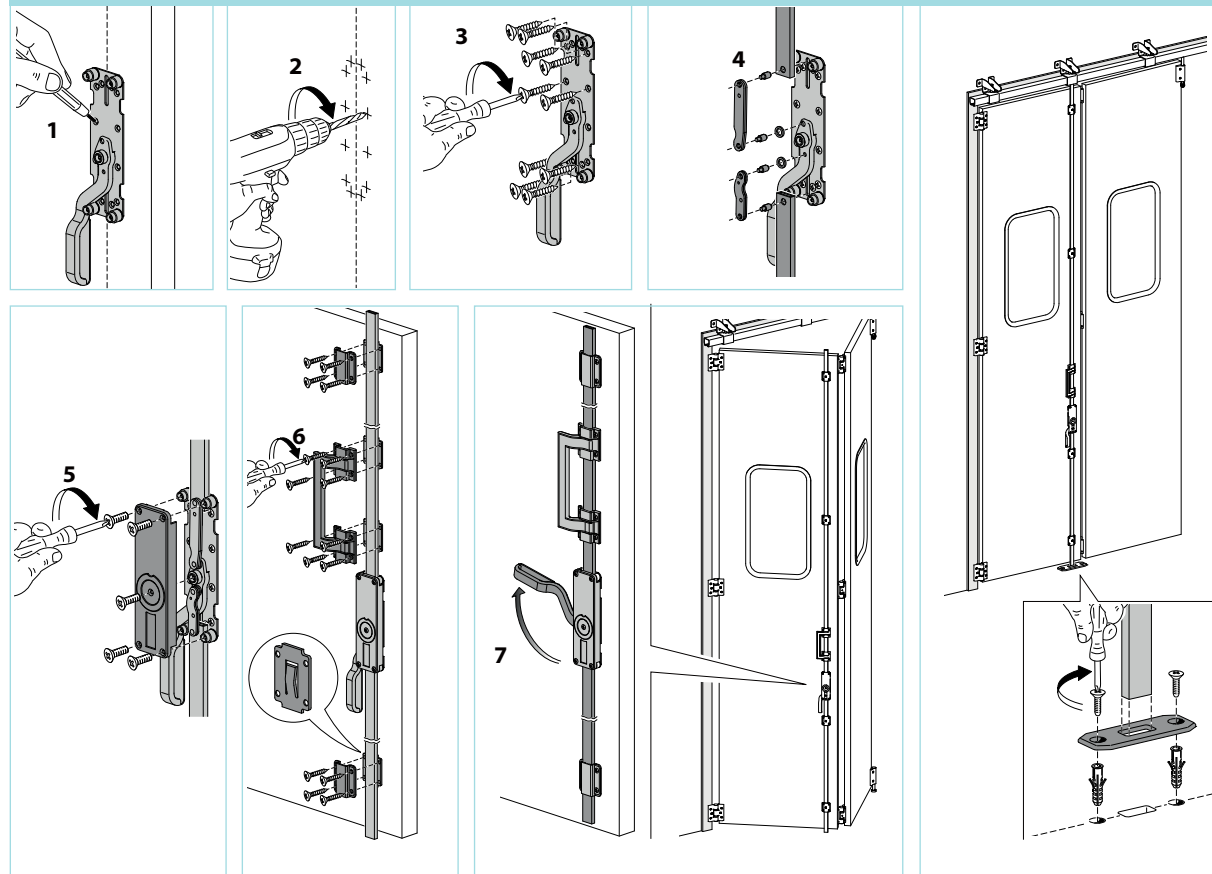

Mounting instructions art. 698 MC - DX

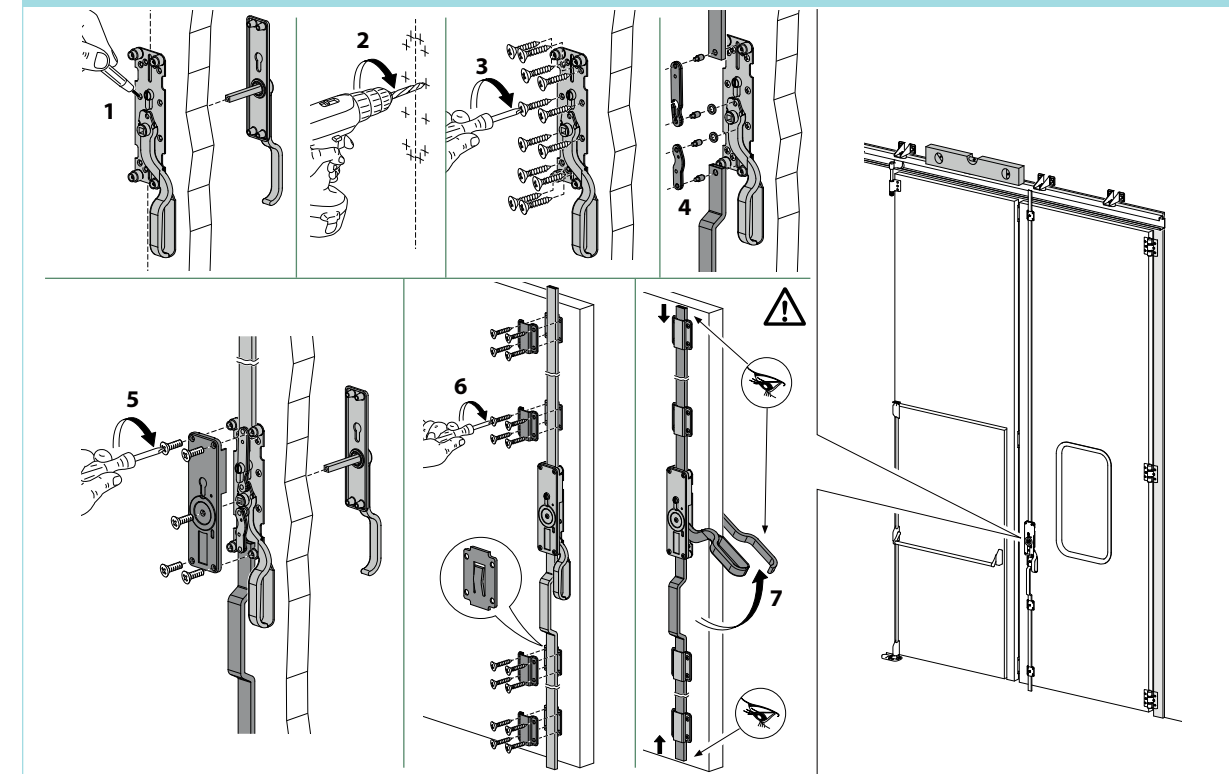



A370 P

Cerniera doppia piccola in alluminio piana

Small flat aluminium double hinge
Paumelle double petite en aluminium plate
Doppelscharnier klein aus Aluminium flach
Perno doble pequeño de aluminio chato
Малый плоский двойной шарнир из алюминия



CODE	ART.	Size	Portata Capacity	Box info	
				Pcs per pack	Kg
11630405 503	A370 P	Piccolo	200 kg	12	6,0

Finishing: RAL 9005 nero / RAL 9005 black

Categoria commerciale: 3D

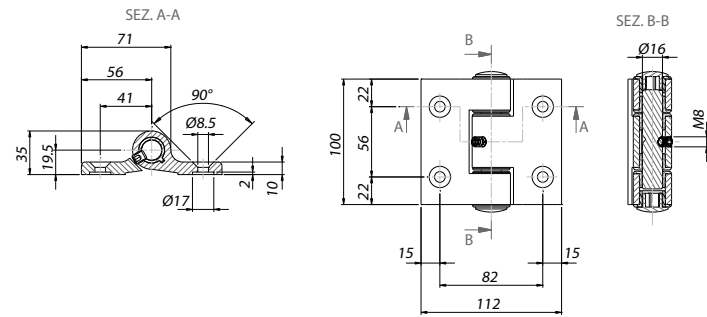

A380 P

Cerniera doppia piccola in alluminio con battute

Small aluminium double hinge with steps
Paumelle double petite en aluminium avec butées
Doppelscharnier klein aus Aluminium mit Stützen
Perno doble pequeño de aluminio con topes
Малый двойной шарнир из алюминия с упорами



CODE	ART.	Size	Portata Capacity	Box info	
				Pcs per pack	Kg
11630505 503	A380 P	Piccolo	200 kg	12	10,0

Finishing: RAL 9005 nero / RAL 9005 black

Categoria commerciale: 3D

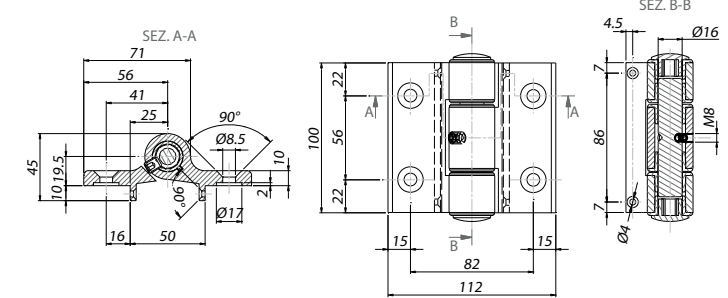

A371 P

Cerniera doppia piccola in alluminio senza perno

Small flat aluminium double hinge, without pin
Paumelle double petite en aluminium plate, sans pivot
Doppelscharnier klein aus Aluminium flach, ohne Bolzen
Perno doble pequeño de aluminio sin eje
Малый двойной шарнир из алюминия без штифта



CODE	ART.	Size	Portata Capacity	Box info	
				Pcs per pack	Kg
11630905 503	A371 P	Piccolo	200 kg	4	1,4

Finishing: RAL 9005 nero / RAL 9005 black

Categoria commerciale: 3D

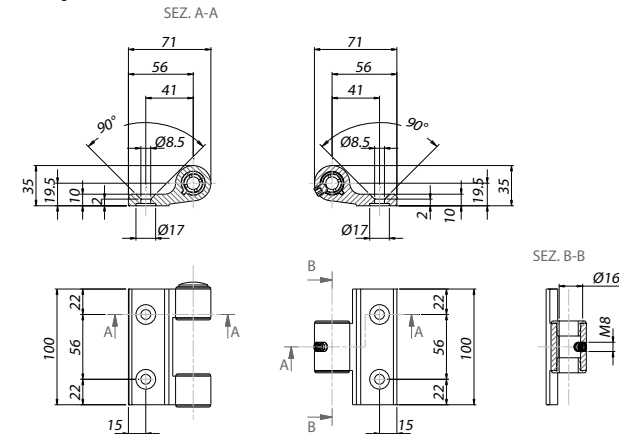

A380 R

Cerniera doppia in alluminio piana, regolabile

Flat aluminium double hinge, adjustable
Paumelle double en aluminium plate, réglable
Doppelscharnier aus aluminium flach, regulierbar
Perno doble de aluminio chato, regulable
Плоский двойной шарнир из алюминия, регулируемый



CODE	ART.	Size	Portata Capacity	Box info	
				Pcs per pack	Kg
11634005 503	A380 R	400 kg	400 kg	4	4,0

Finishing: RAL 9005 nero / RAL 9005 black

Categoria commerciale: 3D

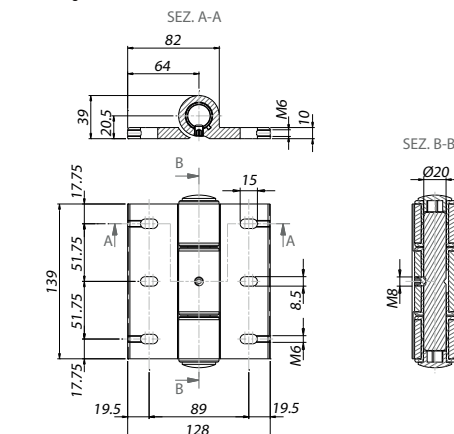

A380 G

Cerniera doppia grande in alluminio con battute

Large aluminium double hinge with steps
Paumelle double grande en aluminium avec butées
Doppelscharnier gross aus Aluminium mit Stützen
Perno doble grande de aluminio con topes
Большой двойной шарнир из алюминия с упорами



CODE	ART.	Size	Portata Capacity	Box info	
				Pcs per pack	Kg
11630511 503	A380 G	Grande	400 kg	12	11,7

Finishing: RAL 9005 nero / RAL 9005 black

Categoria commerciale: 3D

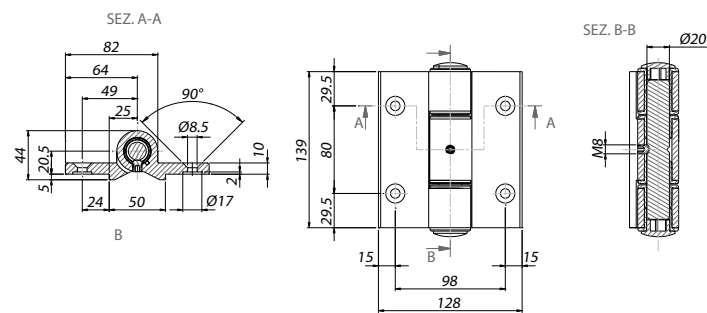

A381 G

Cerniera doppia grande in alluminio con battute, senza perno

Large aluminium double hinge with steps, without pin
Paumelle double grande en aluminium avec butées, sans pivot
Doppelscharnier gross aus Aluminium mit Stützen, ohne Bolzen
Perno doble grande de aluminio con topes, sin eje
Большой двойной шарнир из алюминия с упорами, без штифта



CODE	ART.	Size	Portata Capacity	Box info	
				Pcs per pack	Kg
11631011 503	A381 G	Grande	400 kg	4	2,8

Finishing: RAL 9005 nero / RAL 9005 black

Categoria commerciale: 3D

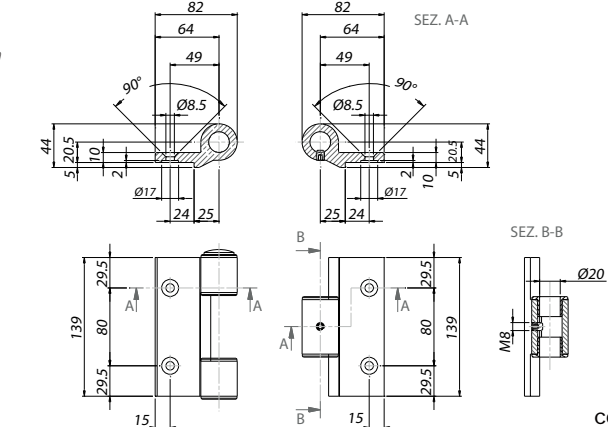



A381 P

Cerniera doppia piccola in alluminio con battute, senza perno

Small aluminium double hinge with steps, without pin
Paumelle double petite en aluminium, avec butées, sans pivot
Doppelscharnier klein aus Aluminium mit Stützen, ohne Bolzen
Perno doble pequeño de aluminio con topes, sin eje
Малый двойной шарнир из алюминия с упорами, без штифта



CODE	ART.	Size	Portata Capacity	Box info	
				Pcs per pack	Kg
11631005 503	A381 P	Piccolo	200 kg	4	2,2

Finishing: RAL 9005 nero / RAL 9005 black

Categoria commerciale: 3D

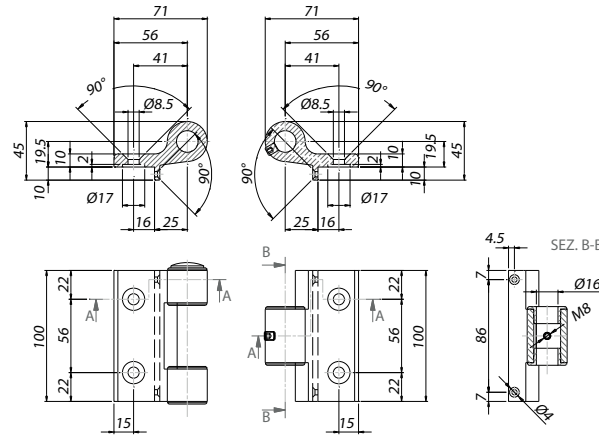

P365

Cerniera singola in alluminio pressofuso con battuta disassata

Die-cast aluminium hinge with off-centre step
Paumelle simple en aluminium moulée avec butée désaxée
Einzel-Scharnier aus Alu-druckguss mit ausserachsiger Stütze
Perno de aluminio fundido a presión con tope descentrado
Одинарный шарнир из литого алюминия с упором, смещенный



CODE	ART.	Portata Capacity	Box info	
			Pcs per pack	Kg
11644015 503	P 365	200 kg	4	1,8

Finishing: RAL 9005 nero / RAL 9005 black

Categoria commerciale: 3D

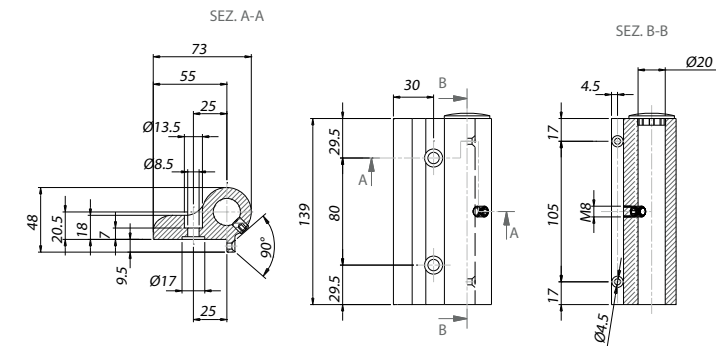

A384 P

Cerniera singola piccola in alluminio piana

Small flat aluminium hinge
Paumelle simple petite en aluminium plate
Einzel-Scharnier klein aus Aluminium flach
Perno pequeño de aluminio chato
Малый плоский одинарный шарнир из алюминия



CODE	ART.	Size	Portata Capacity	Box info	
				Pcs per pack	Kg
11632405 503	A384 P	Piccolo	150 kg	4	1,0

Finishing: RAL 9005 nero / RAL 9005 black

Categoria commerciale: 3D

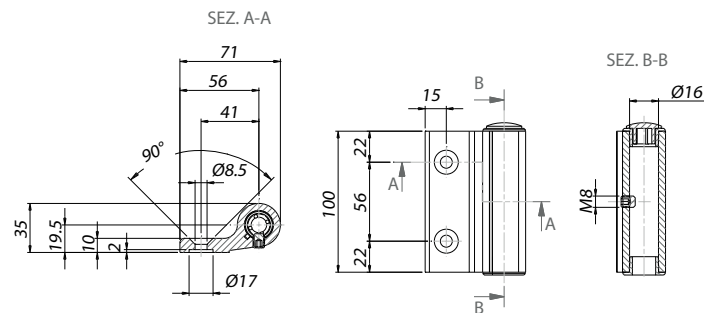

P365 R

Cerniera singola ridotta in alluminio pressofuso con battuta

Reduced die-cast aluminium hinge with step
Paumelle simple reduite en aluminium moulée avec butée
Einzel-scharnier reduziert aus Alu-druckguss mit Stütze
Perno reducido de aluminio fundido a presión con tope
Уменьшенный одинарный шарнир из литого алюминия с упором



CODE	ART.	Portata Capacity	Box info	
			Pcs per pack	Kg
11645515 503	P365 R	200 kg	4	1,6

Finishing: RAL 9005 nero / RAL 9005 black

Categoria commerciale: 3D

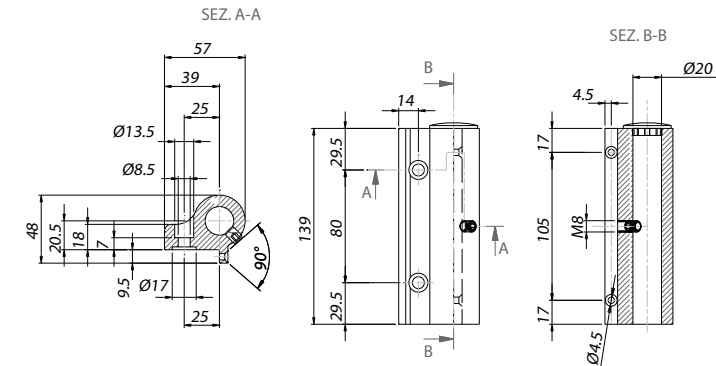

A385 P

Cerniera singola piccola in alluminio con battuta

Small aluminium hinge with step
Paumelle simple petite en aluminium avec butée
Einzel-scharnier klein aus Aluminium mit Stütze
Perno pequeño de aluminio con tope
Малый одинарный шарнир из алюминия с упором



CODE	ART.	Size	Portata Capacity	Box info	
				Pcs per pack	Kg
11632505 503	A385 P	Piccolo	150 kg	4	1,0

Finishing: RAL 9005 nero / RAL 9005 black

Categoria commerciale: 3D

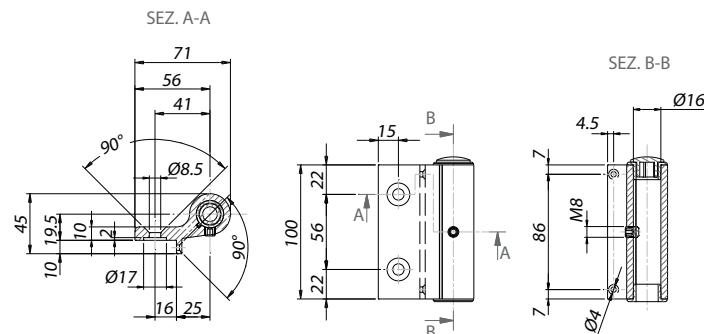

P368 I

Cerniera inferiore in alluminio pressofuso decentrata

Off-centre die-cast aluminium lower hinge
Paumelle inférieure en aluminium moulée décentrée
Unteres-Scharnier aus Alu-druckguss dezentriert
Perno inferior de aluminio fundido a presión descentrado
Нижний шарнир из литого алюминия, смещенный



CODE	ART.	Portata Capacity	Box info	
			Pcs per pack	Kg
11644500 503	P368 I	200 kg	4	2,6

Finishing: RAL 9005 nero / RAL 9005 black

Categoria commerciale: 3D

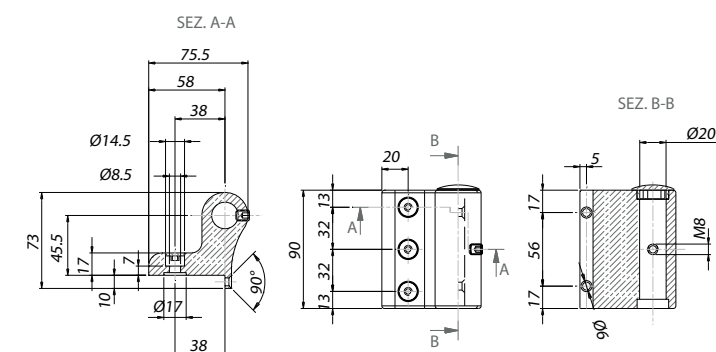



P368 M

Cerniera superiore/inferiore
maggiorata decentrata

Off-center oversized upper/lower hinge
Paumelle supérieure/inferieure surdimensionnée décentralisée
Dezentralisiertes oberes/unteres Schamier vergrößert
Pernio superior/inferior sobredimensionado descentrado
Верхний/нижний шарнир увеличенный смещенный



CODE	ART.	Portata Capacity	Box info	
			Pcs per pack	Kg
11644560 503	P368 M	200 kg	4	2,5

Finishing: RAL 9005 nero / RAL 9005 black

Categoria commerciale: 3D

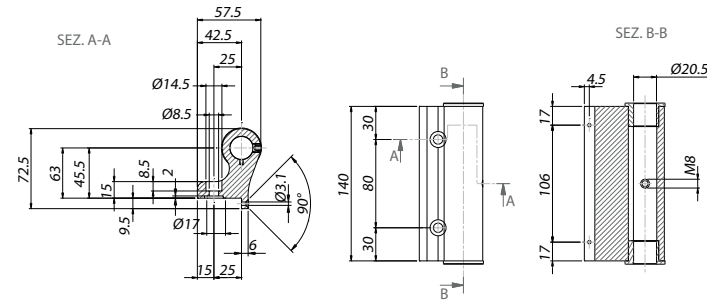

P368 S

Cerniera superiore in alluminio
pressofuso decentrata

Off-centre die-cast aluminium upper hinge
Paumelle supérieure en aluminium moulée décentrée
Oberes Schamier aus Alu-druckguss dezentriert
Pernio superior de aluminio fundido a presión descentrado
Верхний шарнир из литого алюминия, смещенный



CODE	ART.	Portata Capacity	Box info	
			Pcs per pack	Kg
11644550 503	P368 S	130 kg	4	2,6

Finishing: RAL 9005 nero / RAL 9005 black

Categoria commerciale: 3D

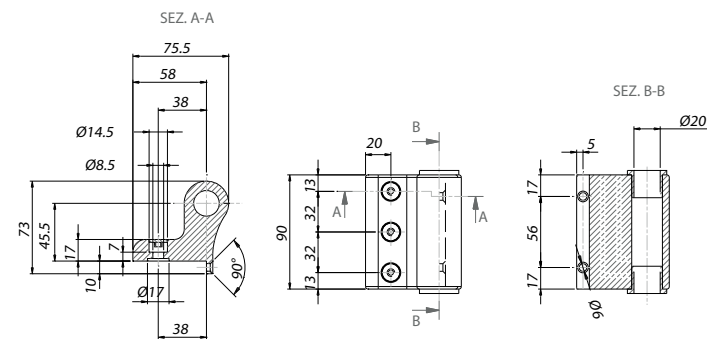

P370

Cerniera doppia in alluminio
pressofuso piana

Flat die-cast aluminium double hinge
Paumelle double en aluminium moulée plate
Doppelschamier aus Alu-druckguss flach
Pernio doble de aluminio fundido a presión chato
Плоский двойной шарнир из литого алюминия



CODE	ART.	Portata Capacity	Box info	
			Pcs per pack	Kg
11640710 503	P370	300 kg	12	12,6

Finishing: RAL 9005 nero / RAL 9005 black

Categoria commerciale: 3D

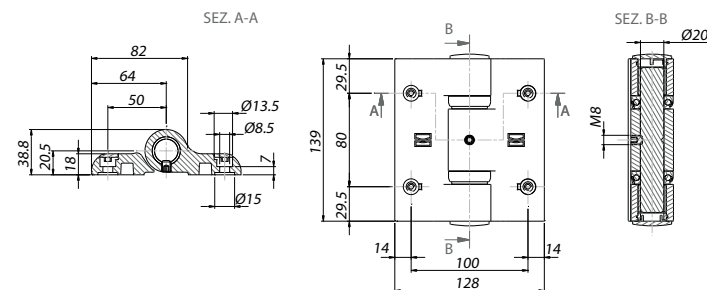

P371

Cerniera doppia in alluminio
pressofuso piana, senza perno

Flat die-cast aluminium double hinge, without pin
Paumelle double en aluminium moulée plate, sans pivot
Doppelschamier aus Alu-druckguss flach, ohne Bolzen
Pernio doble de aluminio fundido a presión chato, sin eje
Плоский двойной шарнир из литого алюминия без штифта



CODE	ART.	Portata Capacity	Box info	
			Pcs per pack	Kg
11641210 503	P371	300 kg	4	3,1

Finishing: RAL 9005 nero / RAL 9005 black

Categoria commerciale: 3D

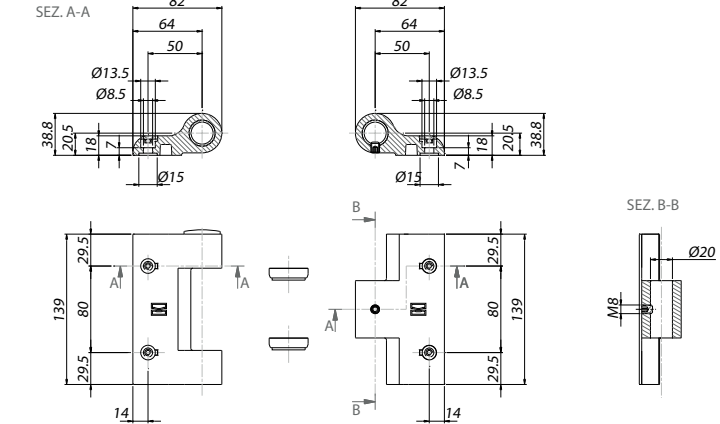

P380

Cerniera doppia in alluminio
pressofuso con battute

Die-cast aluminium double hinge with steps
Paumelle double en aluminium moulée avec butées
Doppelschamier aus Alu-druckguss mit Stützen
Pernio doble de aluminio fundido a presión con topes
Плоский двойной шарнир из литого алюминия с упорами



CODE	ART.	Portata Capacity	Box info	
			Pcs per pack	Kg
11640510 503	P380	300 kg	12	13,0

Finishing: RAL 9005 nero / RAL 9005 black

Categoria commerciale: 3D

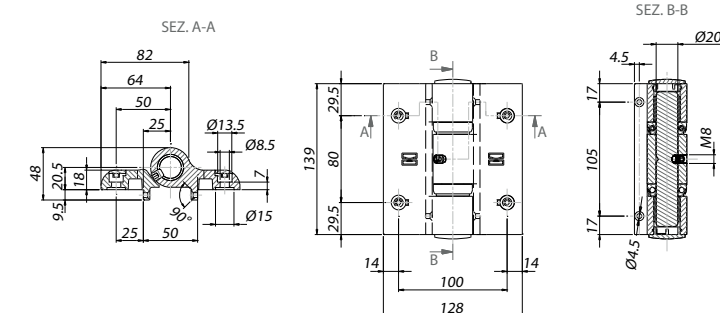

P381

Cerniera doppia in alluminio pressofuso
con battute, senza perno

Die-cast aluminium double hinge, without pin
Paumelle double en aluminium moulée avec butées, sans pivot
Doppelschamier aus Alu-druckguss mit Stützen, ohne Bolzen
Pernio doble de aluminio fundido a presión con topes, sin eje
Двойной шарнир из литого алюминия с упорами без штифта



CODE	ART.	Portata Capacity	Box info	
			Pcs per pack	Kg
11641010 503	P381	300 kg	4	5,0

Finishing: RAL 9005 nero / RAL 9005 black

Categoria commerciale: 3D

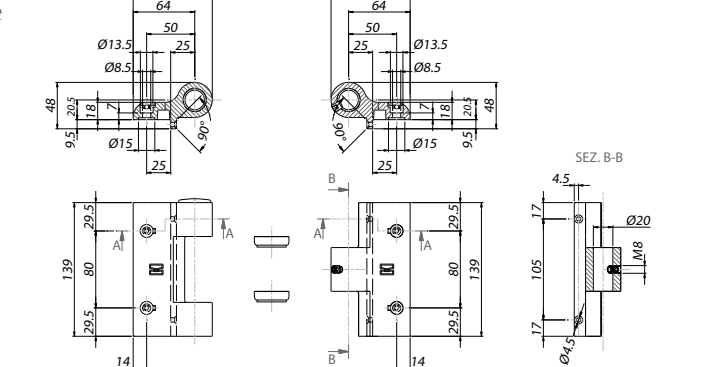

P385

Cerniera singola in alluminio pressofuso con battuta
 Die-cast aluminium hinge with step
 Paumelle simple en aluminium moulée avec butée
 Einzel-scharnier aus Alu-druckguss mit Stütze
 Pernio de aluminio fundido a presión con tope
 Одинарный шарнир из литого алюминия с упором



CODE	ART.	Portata Capacity	Box info	
			Pcs per pack	Kg
11642510 503	P385	200 kg	4	2,2

Finishing: RAL 9005 nero / RAL 9005 black

Categoria commerciale: 3D

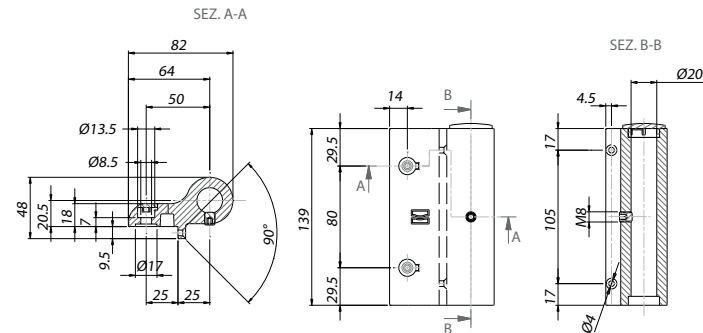

R378

Perno per cerniera P380
 Pin for hinge P380
 Pivot pour paumelle P380
 Bolzen für Scharnier P380
 Eje para pernio P380
 Штырь для шарнира P380



CODE	ART.	Box info	
		Pcs per pack	Kg
10310601 001	R378	20	6,0

Finishing: Zincato / Galvanized

Categoria commerciale: 3E

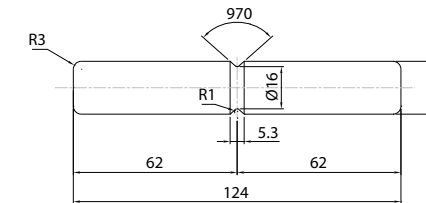

R383-13.5

Tappo coprivite per cerniera P380
 Screw cover for hinge P380
 Embout couvre-vis pour paumelle P380
 Stöpsel für P380 schraube
 Tapatornillo para pernio P380
 Заглушка для закрытия винта для шарнира P380



CODE	ART.	Box info	
		Pcs per pack	Kg
10310702	R383-13.5	200	0,8

Finishing: RAL 9005 nero / RAL 9005 black

Categoria commerciale: 3E

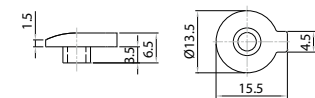

400

Cuscinetto 20x36x11 zinc.
 Nero per P380
 Bearing 20x36x11 black galvanized for p380
 Roulement 20x36x11 zinc. Noir pour p380
 Lager 20x36x11 schwarz-verzinkt für p380
 Rodamiento 20x36x11 galvaniz. Negro para P380
 Подшипник 20x36x11 цинк. Черный для P380



CODE	ART.	Box info	
		Pcs per pack	Kg
12400526 003	400	100	4,7

Finishing: Zincato nero / Black Galvanized

Categoria commerciale: 1E

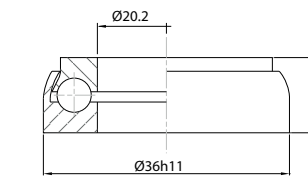

R383-33

Tappo di testa per cerniera P380
 Supperper for hinge P380
 Embout de tête pour paumelle P380
 Stöpsel für Scharnierkopf P380
 Tapa para pernio P380
 Торцевая заглушка для шарнира P380



CODE	ART.	Box info	
		Pcs per pack	Kg
10310701	R383-33	200	0,8

Finishing: RAL 9005 nero / RAL 9005 black

Categoria commerciale: 3E

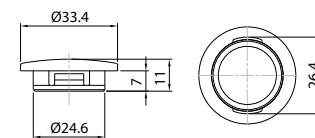



Schema con ante chiuse
Diagram with closed doors

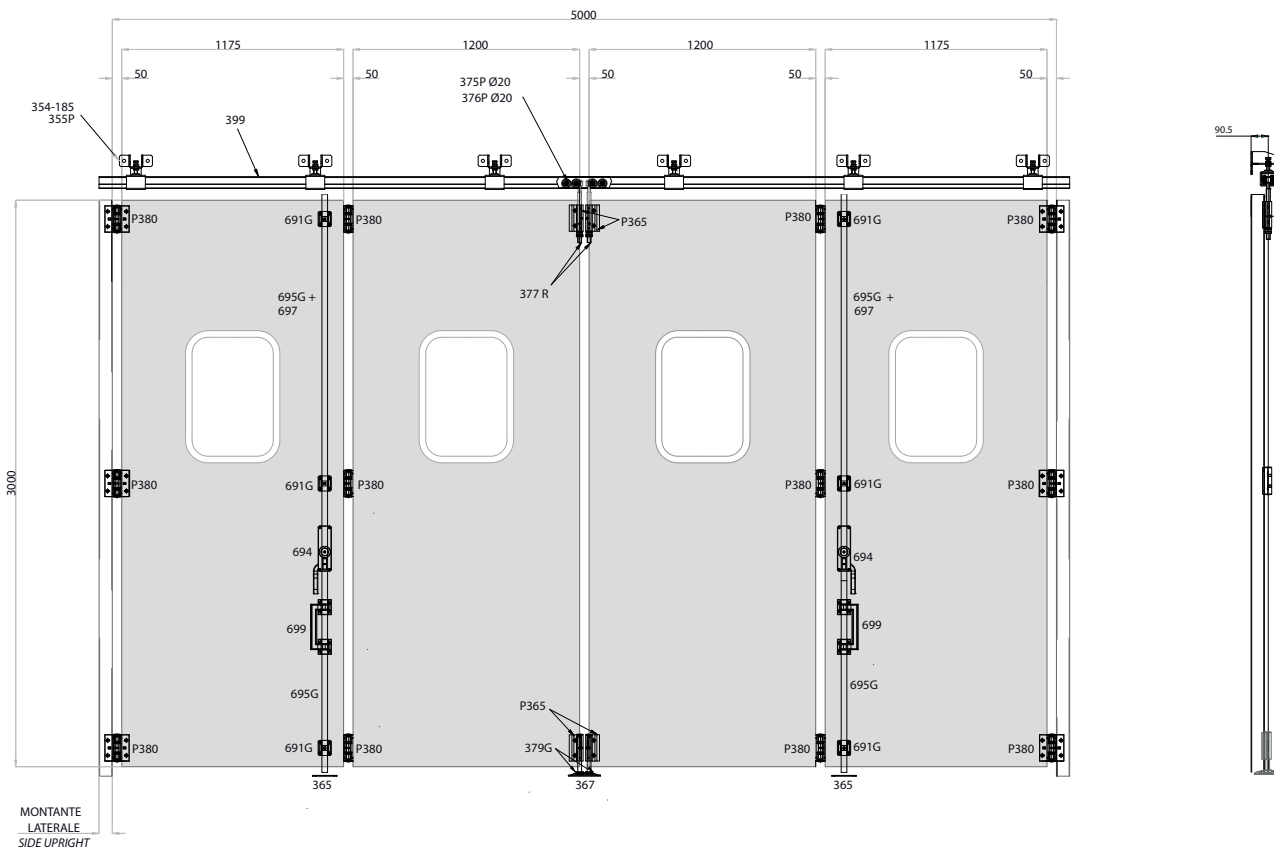

Schema con ante aperte/chiuse
Diagram with open/closed doors

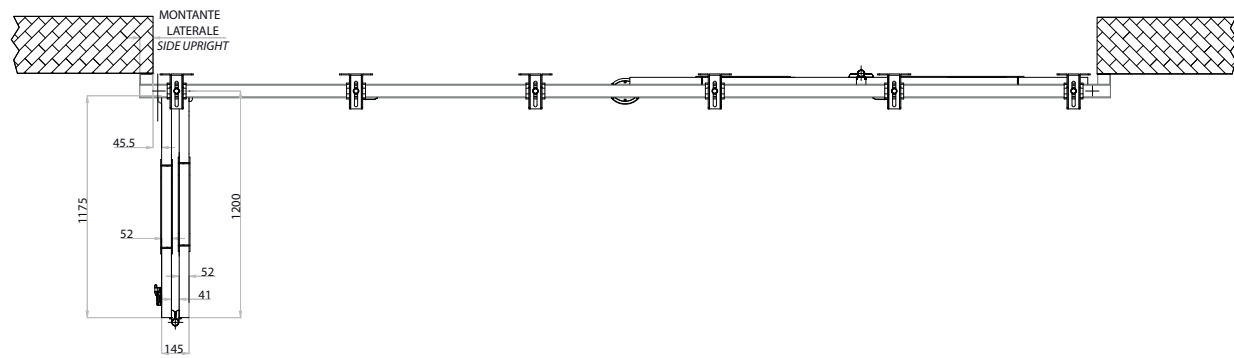

Particolari tecnici
Technical details

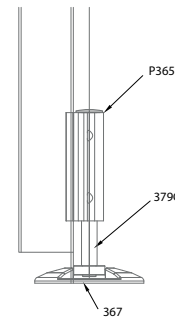
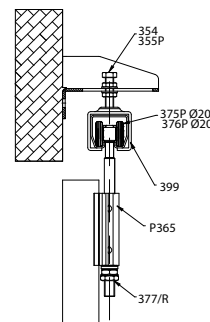
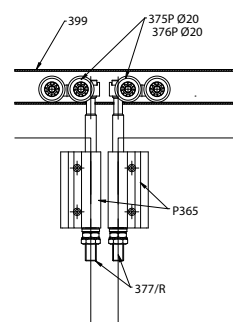

	ART.	DESCRIPTION	Box info Pcs per pack	PAG.
	399	Monorotaia superiore per carrelli 4 ruote piccola zincata Small galvanized upper guide for trolleys with four wheels / Rail supérieur pour chariots 4 galets petits zingues / Obere laufschiene für rollenapparate mit 4 rollen klein verzinkt / Monocarri superior pequeño galvanizado para carros con 4 ruedas / Верхний монорейль для тележек с 4 колесами малый оцинкованный	1 (6.0 m)	311
	354-185	Staffa regolabile a parete mm. 185 Adjustable wall rod 185 mm. / Support réglable au mur mm. 185 / Regulierbarer wandbügel 185 mm / Placa regulable de pared 185 mm / Регулируемый настенный кронштейн мм 185	6	299
	355 P	Supporto guida regolabile Adjustable guide support / Support guide réglable / Regulierbare führung / Soporte guía regulable / Опора регулируемой направляющей	6	300
	375 P20 / 376 P20	Carrello piccolo a 4 ruote in acciaio / nylon Small steel trolley with four wheels - nylon / Chariot petit a 4 galets en acier - nylon / Rollenapparat klein mit 4 stahlrollen - nylonrollen / Carro pequeño con 4 ruedas de acero - nylon / Маленькая тележка с 4 нейлоновыми/стальными колесами	2	307
	694 MC	Cariglione star grande Large star lever bolt / Cremona star grande / Treibriegel star gross / Falleba star grande / Большой болтовой рычаг star	1 DX + 1 SX	321
	699	Maniglione di trascinamento in nylon con passanti Nylon pull handle with guides / Poignée d'entraînement en nylon avec traversants / Nylongriff zum ziehen mit laschen / Tirador de nylon con puentes / Ручка из нейлона со сквозными направляющими	2	323
	695 G	Asta di chiusura tubolare 30x10 Closing tubular rod 30x10 / Tringle tubulaire de fermeture 30x10 / Rohrverschlussstange 30x10 / Varilla de cierre tubular 30x10 / Закрывающий стержень трубчатый 30x10	2 (1.20 m) + 2 (3.0 m)	322
	691 G	Passante per aste 30x10 Rod guide 30x10 / Traversant pour tringles 30x10 / Lasche für stangen 30x10 / Puente para varillas 30x10 / Сквозная направляющая для стержней 30x10	6	319
	365	Incontro per aste Floor strike plate for rods / Butoir pour tringles / Aufaufschuh für stangen / Encuentro para varillas / Упор для стержней	2	303
	367	Incontro a pavimento in nylon nero, con rinforzo in acciaio Black nylon floor strike plate, with steel reinforcement / Butoir au sol en nylon noir, avec renfort en acier / Bodenaufschuh aus schwarzem nylon mit verstärkung aus stahl / Encuentro de nylon negro para suelo, con refuerzo de acero / Напольный упор из черного нейлона, со стальным укреплением	1	303
	P380	Cerniera doppia in alluminio pressofuso con battute Die-cast aluminium double hinge with steps / Paumelle double en aluminium moulée avec butées / Doppelscharnier aus alu-druckguss flach, ohne bolzen / Pernio doble de aluminio fundido a presión con tope / Плоский двойной шарнир из литого алюминия с упорами	12	331
	P365	Cerniera singola in alluminio pressofuso con battuta disassata Die-cast aluminium hinge with off-centre stop / Paumelle simple en aluminium moulée avec butée désaxée / Einzel-scharnier gross aus aluminium mit stütze / Pernio de aluminio fundido a presión con tope descentrado / Одинарный шарнир из литого алюминия с упором, смещенный	4	329
	377 R	Perno superiore ribassato Lowered upper pin / Pivot supérieur surbaisse / Oberer bolzen herabgesenkt / Perno superior rebajado / Верхний штырь пониженный	2	308
	379 G 135	Perno inferiore regolabile con cuscinetto Adjustable lower pin with bearing / Pivot inférieur réglable avec roulement / Regulierbarer unterer bolzen mit kugellager / Perno inferior regulable con rodamiento / Нижний регулируемый штифт с подшипником	2	305
	239	Tappo ammortizzatore ante Door leaf suppperper / Embout d'amortissage vantaux / Stossdämpfer für türe / Amortiguador hojas / Амортизирующая пробка створки	2	295



Schema con ante chiuse
Diagram with closed doors

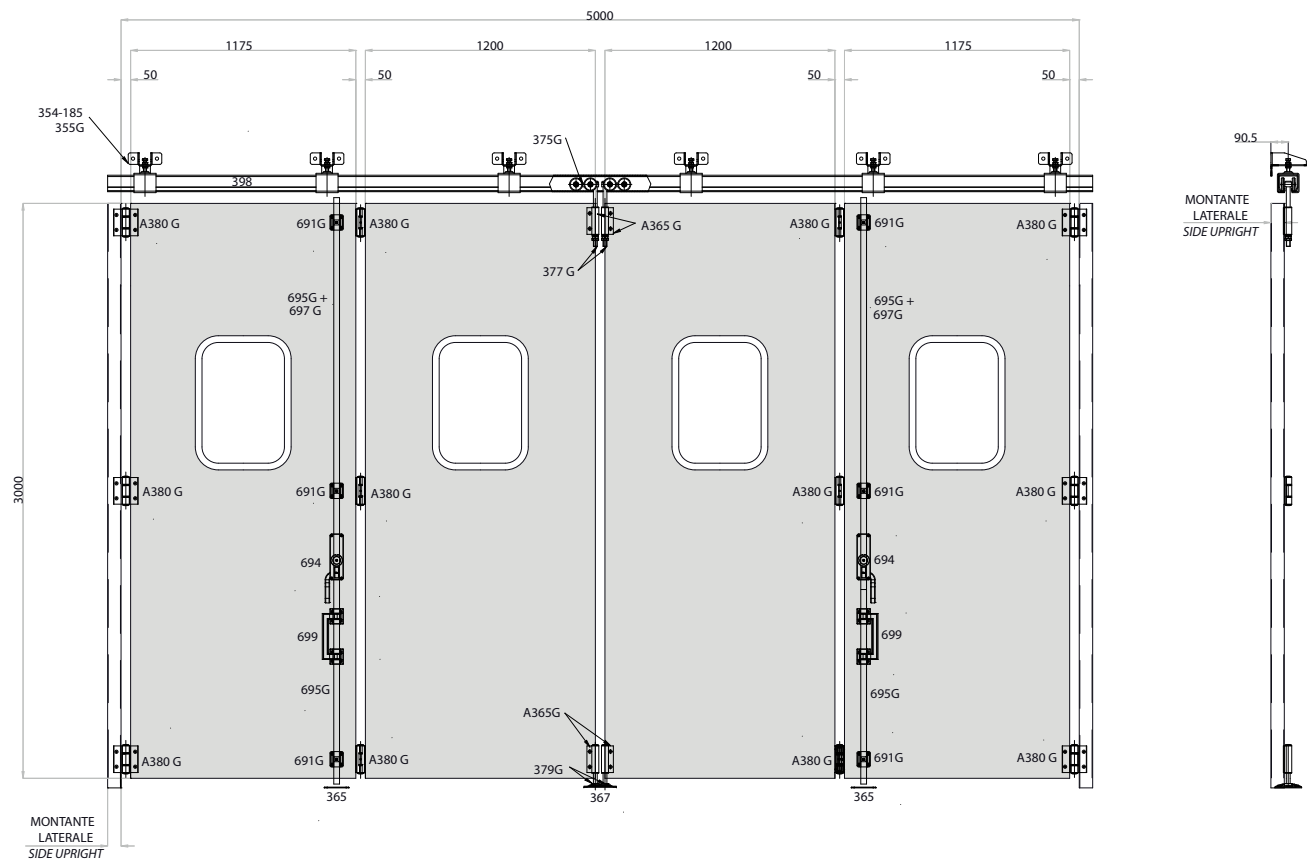

Schema con ante aperte/chiusa
Diagram with open/closed doors

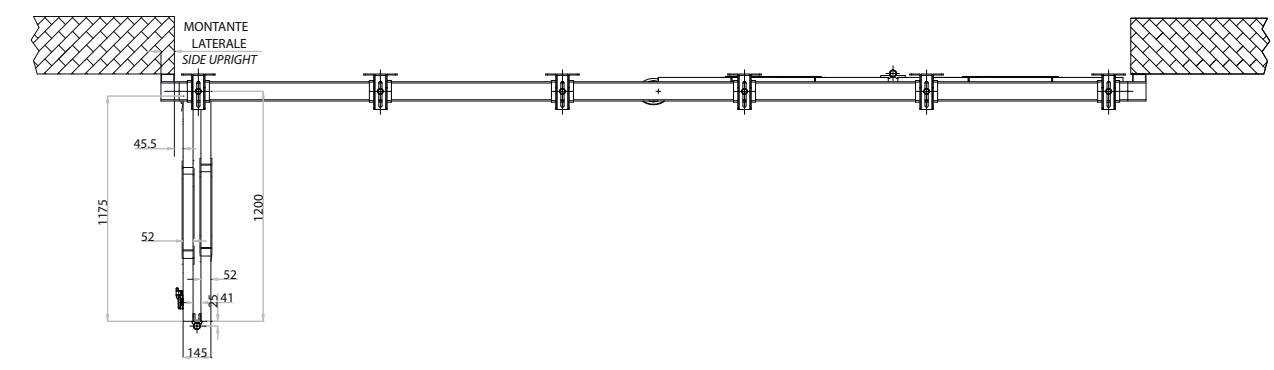

Particolari tecnici
Technical details

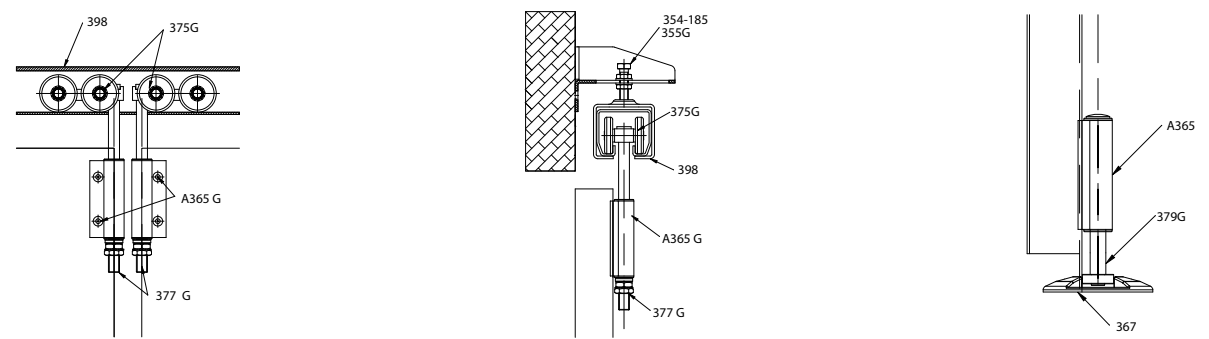

	ART.	DESCRIPTION	Box info Pcs per pack	PAG.
	398	Monorotaia superiore per carrelli 4 ruote grande zincata Large galvanized upper guide for trolleys with four wheels / Rail supérieur pour chariots 4 galets grands zingués / Obere laufschiene für rollenapparate mit 4 rollen gross verzinkt / Monocaril superior grande galvanizado para carros con 4 ruedas / Верхний монорельс для тележек с 4 колесами большой оцинкованный	1 (6.0 m)	311
	354-185	Staffa regolabile a parete mm. 185 Adjustable wall rod 185 mm. / Support réglable au mur mm. 185 / Regulierbarer wandbügel 185 mm / Placa regulable de pared 185 mm / Регулируемый настенный кронштейн мм 185	6	299
	355 G	Supporto guida regolabile Adjustable guide support / Support guide réglable / Regulierbare führung / Soporte guía regulable / Опора регулируемой направляющей	6	300
	375 G	Carrello grande a 4 ruote in acciaio per perno da mm. 20 Large steel trolley with four wheels for pin, 20 mm. / Chariot grand a 4 galets en acier pour pivot de mm. 20 / Rollenapparat gross mit 4 stahlrollen für bolzen 20 mm / Carro grande con 4 ruedas de acero para perno de 20 mm / Большая тележка 4 стальными колесами для штифта мм 20	2	307
	694 MC	Cariglione star grande Large star lever bolt / Cremona star grande / Treibriegel star gross / Falleba star grande / Большой болтовой рычаг star	1 DX + 1 SX	321
	699	Maniglione di trascinamento in nylon con passanti Nylon pull handle with guides / Poignée d'entraînement en nylon avec traversants / Nylongriff zum ziehen mit laschen / Tirador de nylon con puentes / Ручка из нейлона со сквозными направляющими	2	323
	695 G	Asta di chiusura tubolare 30x10 Closing tubular rod 30x10 / Tringle tubulaire de fermeture 30x10 / Rohrverschlussstange 30x10 / Varilla de cierre tubular 30x10 / Закрывающий стержень трубчатый 30x10	2 (1.20 m) + 2 (3.0 m)	322
	691 G	Passante per aste 30x10 Rod guide 30x10 / Traversant pour tringles 30x10 / Lasche für stangen 30x10 / Puente para varillas 30x10 / Сквозная направляющая для стержней 30x10	6	319
	365	Incontro per aste Floor strike plate for rods / Butoir pour tringles / Aufaufschuh für stangen / Encuentro para varillas / Упор для стержней	2	303
	367	Incontro a pavimento in nylon nero, con rinforzo in acciaio Black nylon floor strike plate, with steel reinforcement / Butoir au sol en nylon noir, avec renfort en acier / Bodenaufschuh aus schwarzem nylon mit verstärkung aus stahl / Encuentro de nylon negro para suelo, con refuerzo de acero / Напольный упор из черного нейлона, со стальным укреплением	1	303
	A380 G	Cerniera doppia grande in alluminio con battute Large aluminium double hinge with steps / Paumelle double grande en aluminium avec boutes / Doppelscharnier klein aus aluminium flach, ohne bolzen / Pernio doble grande de aluminio con topes / Большой двойной шарнир из алюминия с упорами	12	331
	377 G 330	Perno superiore per carrelli Upper pin for trolleys / Pivot supérieur pour chariots / Oberer bolzen für rollenapparate / Perno superior para carros / Верхний штырь для тележек	2	307
	379 G 135	Perno inferiore regolabile con cuscinetto Adjustable lower pin with bearing / Pivot inférieur réglable avec roulement / Regulierbarer unterer bolzen mit kugellager / Perno inferior regulable con rodamiento / Нижний регулируемый штифт с подшипником	2	305
	239	Tappo ammortizzatore ante Door leaf suppper / Embout d'amortissage vantaux / Stossdämpfer für türe / Amortiguador hojas / Амортизирующая пробка створки	2	295



Schema con ante chiuse
Diagram with closed doors

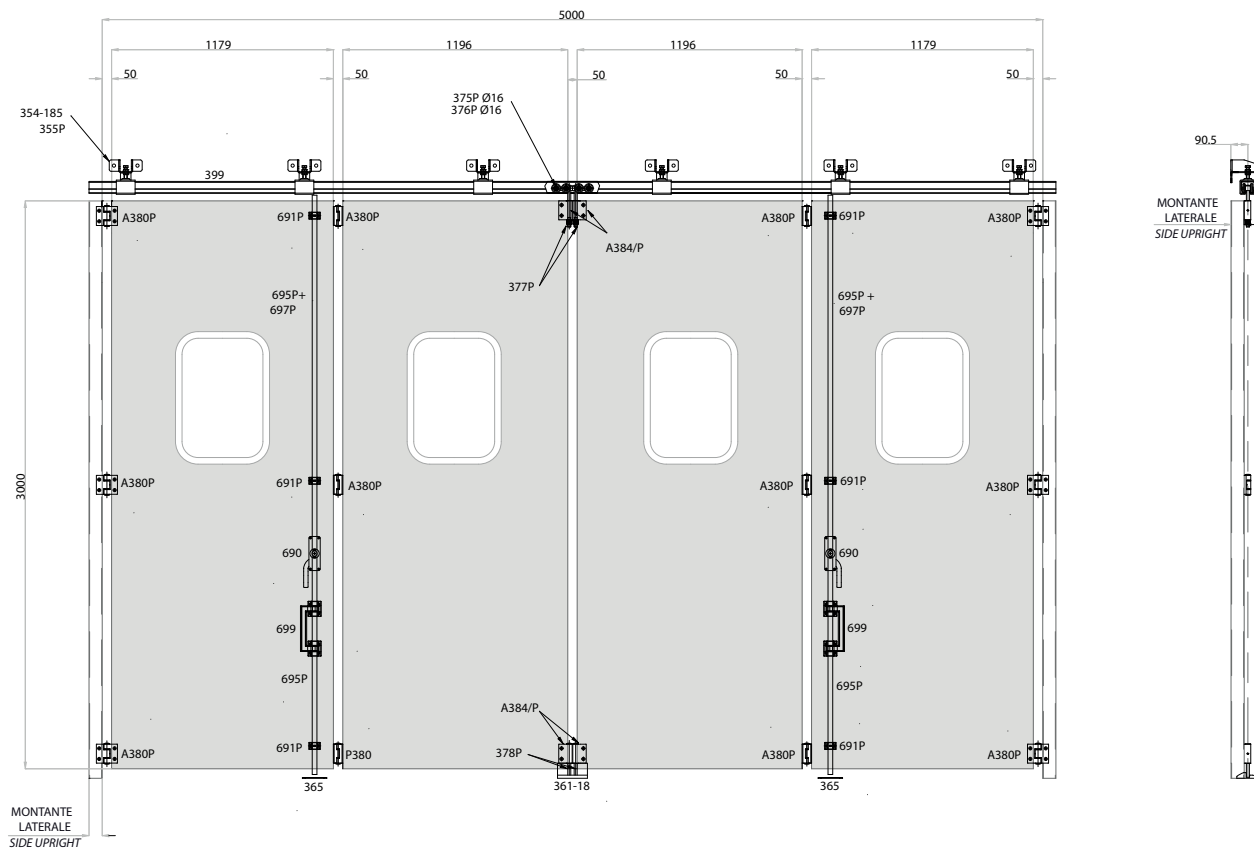

Schema con ante aperte/chiusa
Diagram with open/closed doors

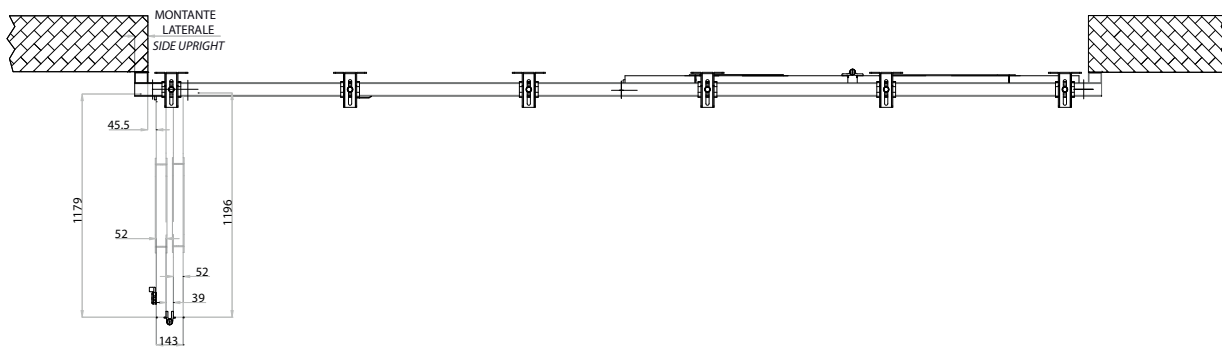

Particolari tecnici
Technical details

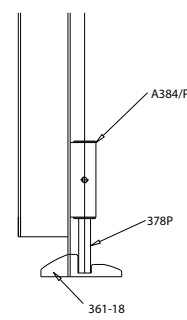
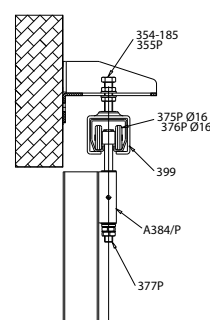
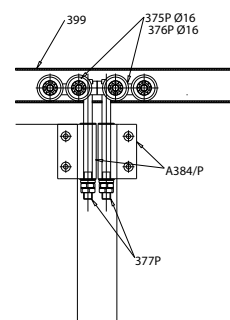

	ART.	DESCRIPTION	Box info Pcs per pack	PAG.
	399	Monorotaia superiore per carrelli 4 ruote piccola zincata Small galvanized upper guide for trolleys with four wheels / Rail supérieur pour chariots 4 galets petits zingues / Obere laufschiene für rollenapparate mit 4 rollen klein verzinkt / Monocami superior pequeño galvanizado para carros con 4 ruedas / Верхний монорельс для тележек с 4 колесами малый оцинкованный	1 (6.0 m)	311
	354-185	Staffa regolabile a parete mm. 185 Adjustable wall rod 185 mm / Support réglable au mur mm. 185 / Regulierbarer wandbügel 185 mm / Placa regulable de pared 185 mm / Регулируемый настенный кронштейн мм 185	6	299
	355 P	Supporto guida regolabile Adjustable guide support / Support guide réglable / Regulierbare führung / Soporte guía regulable / Опора регулируемой направляющей	6	300
	375 P16 / 376 P16	Carrello piccolo a 4 ruote in acciaio / nylon Small steel trolley with four wheels - nylon / Chariot petit a 4 galets en acier - nylon / Rollenapparat klein mit 4 stahlrollen - nylonrollen / Carro pequeño con 4 ruedas de acero - nylon / Маленькая тележка с 4 нейлоновыми/стальными колесами	2	307
	690	Cariglione star piccolo Small star lever bolt / Cremona star petite / Treibriegel star klein / Falleba star pequeña / Малый болтовой рычаг star	1 DX + 1 SX	318
	699	Maniglione di trascinamento in nylon con passanti Nylon pull handle with guides / Poignée d'entraînement en nylon avec traversants / Nylongriff zum ziehen mit laschen / Tirador de nylon con puentes / Ручка из нейлона со сквозными направляющими	2	323
	695 P	Asta di chiusura tubolare 25x10 Closing tubular rod 25x10 / Tingle tubulaire de fermeture 25x10 / Rohrverschlussstange 25x10 / Varilla de cierre tubular 25x10 / Закрывающий стержень трубчатый 25x10	2 (1.20 m) + 2 (3.0 m)	322
	691 P	Passante per aste 30x10 Rod guide 30x10 / Traversant pour tringles 30x10 / Lasche für stangen 30x10 / Puente para varillas 30x10 / Сквозная направляющая для стержней 30x10	6	319
	365	Incontro per aste Floor strike plate for rods / Butoir pour tringles / Auftaufschuh für stangen / Encuentro para varillas / Упор для стержней	2	303
	361 P	Incontro a pavimento in alluminio Aluminium floor strike plate / Butoir au sol en aluminium / Bodenaufschuh aus aluminium / Encuentro de aluminio para el suelo / Алюминиевый напольный упор	1	302
	A380 P	Ceniera doppia piccola in alluminio con battute Small aluminium double hinge with steps / Paumelle double petite en aluminium avec butees / Doppelscharnier klein aus aluminium mit stützen / Pernio doble pequeño de aluminio con topes / Малый двойной шарнир из алюминия с упорами	12	327
	A384 P	Ceniera singola piccola in alluminio piana Small flat aluminium hinge / Paumelle simple petite en aluminium plate / Doppelscharnier gross aus aluminium mit stützen, ohne bolzen / Pernio pequeño de aluminio chato / Малый плоский одинарный шарнир из алюминия	4	328
	377 P	Perno superiore per carrelli Upper pin for trolleys / Pivot supérieur pour chariots / Oberer bolzen für rollenapparate / Perno superior para carros / Верхний штырь для тележек	2	307
	378 P	Perno inferiore regolabile Adjustable lower pin / Pivot inférieur réglable / Unterer bolzen Regulierbar / Perno inferior regulable / Нижний регулируемый штифт	2	305



Schema con ante chiuse
Diagram with closed doors

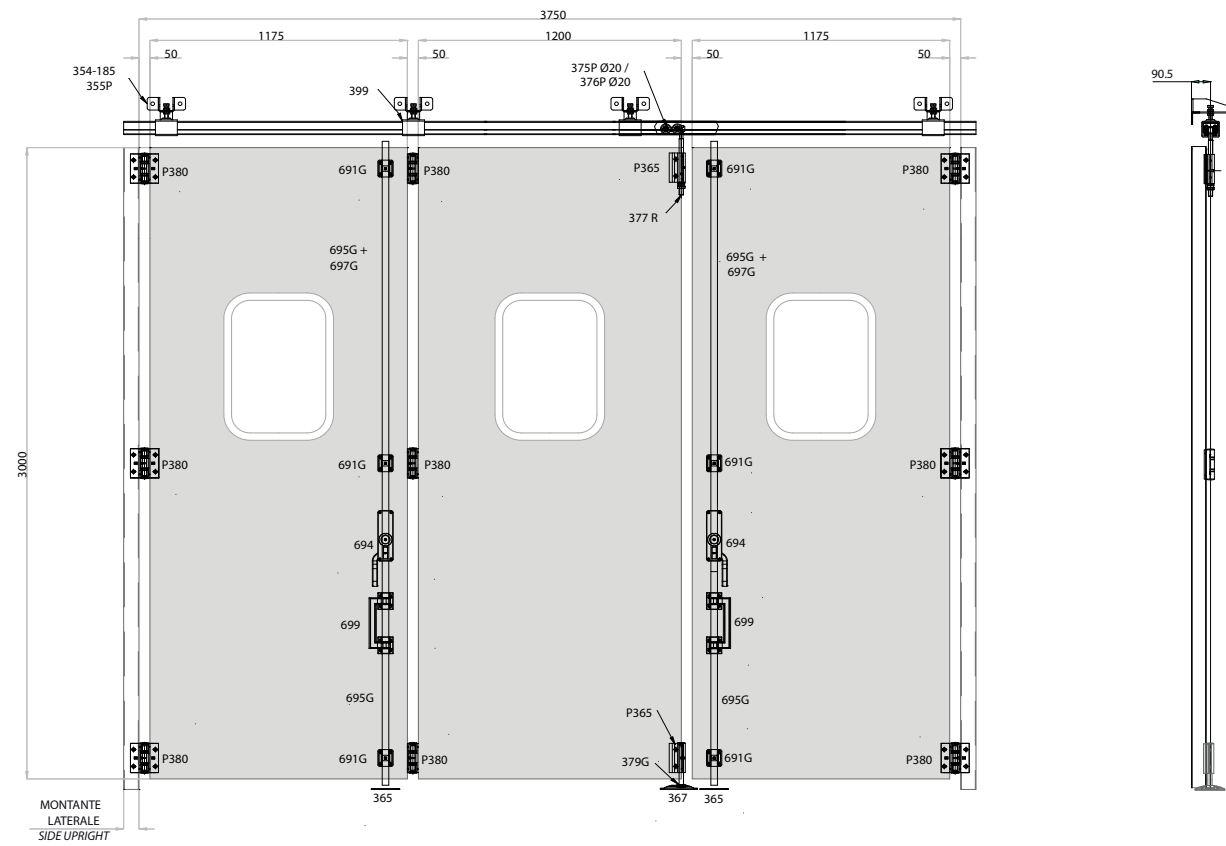

Schema con ante aperte/chiuse
Diagram with open/closed doors

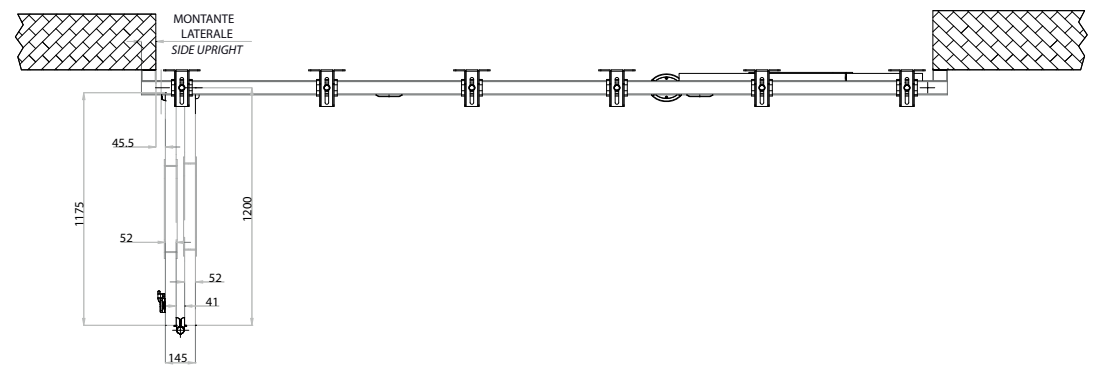

Particolari tecnici
Technical details

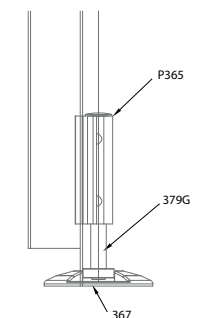
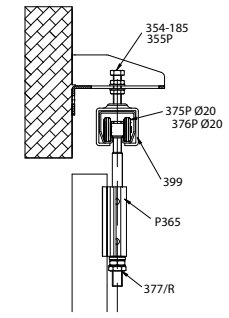
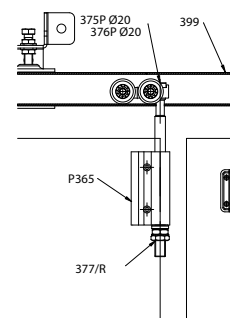

ART.	DESCRIPTION	Box info		PAG.
		Pcs per pack		
399	Monorotaia superiore per carrelli 4 ruote piccola zincata Small galvanized upper guide for trolleys with four wheels Rail supérieur pour chariots 4 galets petits zingues Obere laufschiene für rollenapparate mit 4 rollen klein verzinkt	1	(6.0 m)	311
354-185	Staffa regolabile a parete mm. 185 Adjustable wall rod 185 mm. / Support réglable au mur mm. 185 / Regulierbarer wandbügel 185 mm / Placa regulable de pared 185 mm / Регулируемый настенный кронштейн мм 185	4		299
355 P	Supporto guida regolabile Adjustable guide support / Support guide réglable / Regulierbare führung / Soporte guía regulable / Опора регулируемой направляющей	4		300
375 P20 / 376 P20	Carrello piccolo a 4 ruote in acciaio / nylon Small steel trolley with four wheels - nylon / Chariot petit a 4 galets en acier - nylon / Rollenapparat klein mit 4 stahlrollen - nylonrollen / Carro pequeño con 4 ruedas de acero - nylon / Маленькая тележка с 4 нейлоновыми/стальными колесами	1		307
694 MC	Cariglione star grande Large star lever bolt / Cremona star grande / Treibriegel star gross / Falleba star grande / Большой болтовой рычаг star	1	DX + 1 SX	321
699	Maniglione di trascinamento in nylon con passanti Nylon pull handle with guides / Poignée d'entraînement en nylon avec traversants / Nylongriff zum ziehen mit laschen / Tirador de nylon con puentes / Ручка из нейлона со сквозными направляющими	2		323
695 G	Asta di chiusura tubolare 30x10 Closing tubular rod 30x10 / Tringle tubulaire de fermeture 30x10 / Rohrverschlussstange 30x10 / Varilla de cierre tubular 30x10 / Закрывающий стержень трубчатый 30x10	2	(1.20 m) + 2 (3.0 m)	322
691 G	Passante per aste 30x10 Rod guide 30x10 / Traversant pour tringles 30x10 / Lasche für stangen 30x10 / Puente para varillas 30x10 / Сквозная направляющая для стержней 30x10	6		319
365	Incontro per aste Floor strike plate for rods / Butoir pour tringles / Auftaufschuh für stangen / Encuentro para varillas / Упор для стержней	2		303
367	Incontro a pavimento in nylon nero, con rinforzo in acciaio Black nylon floor strike plate, with steel reinforcement / Butoir au sol en nylon noir, avec renfort en acier / Bodenaufschuh aus schwarzem nylon mit verstärkung aus stahl / Encuentro de nylon negro para suelo, con refuerzo de acero / Напольный упор из черного нейлона, со стальным укреплением	1		303
P380	Cerniera doppia in alluminio pressofuso con battute Die-cast aluminium double hinge with steps / Paumelle double en aluminium moulée avec butees / Doppelscharnier aus alu-druckguss flach, ohne bolzen / Pernio doble de aluminio fundido a presión con topes / Плоский двойной шарнир из литого алюминия с упорами	9		331
P365	Cerniera singola in alluminio pressofuso con battuta disassata Die-cast aluminium hinge with off-centre step / Paumelle simple en aluminium moulée avec butee desaxée / Einzel-scharnier gross aus aluminium mit stütze / Pernio de aluminio fundido a presión con tope descentrado / Одинарный шарнир из литого алюминия с упором, смещенный	2		329
377 R	Perno superiore ribassato Lowered upper pin / Pivot supérieur surbaisse / Oberer bolzen herabgesenkt / Perno superior rebajado / Верхний штырь пониженный	1		308
379 G 135	Perno inferiore regolabile con cuscinetto Adjustable lower pin with bearing / Pivot inférieur réglable avec roulement / Regulierbarer unterer bolzen mit kugellager / Perno inferior regulable con rodamiento / Нижний регулируемый штифт с подшипником	1		305
239	Tappo ammortizzatore ante Door leaf suppperper / Embout d'amortissage vantaux / Stossdämpfer für türe / Amortiguador hojas / Амортизирующая пробка створки	1		295



Schema con ante chiuse
Diagram with closed doors

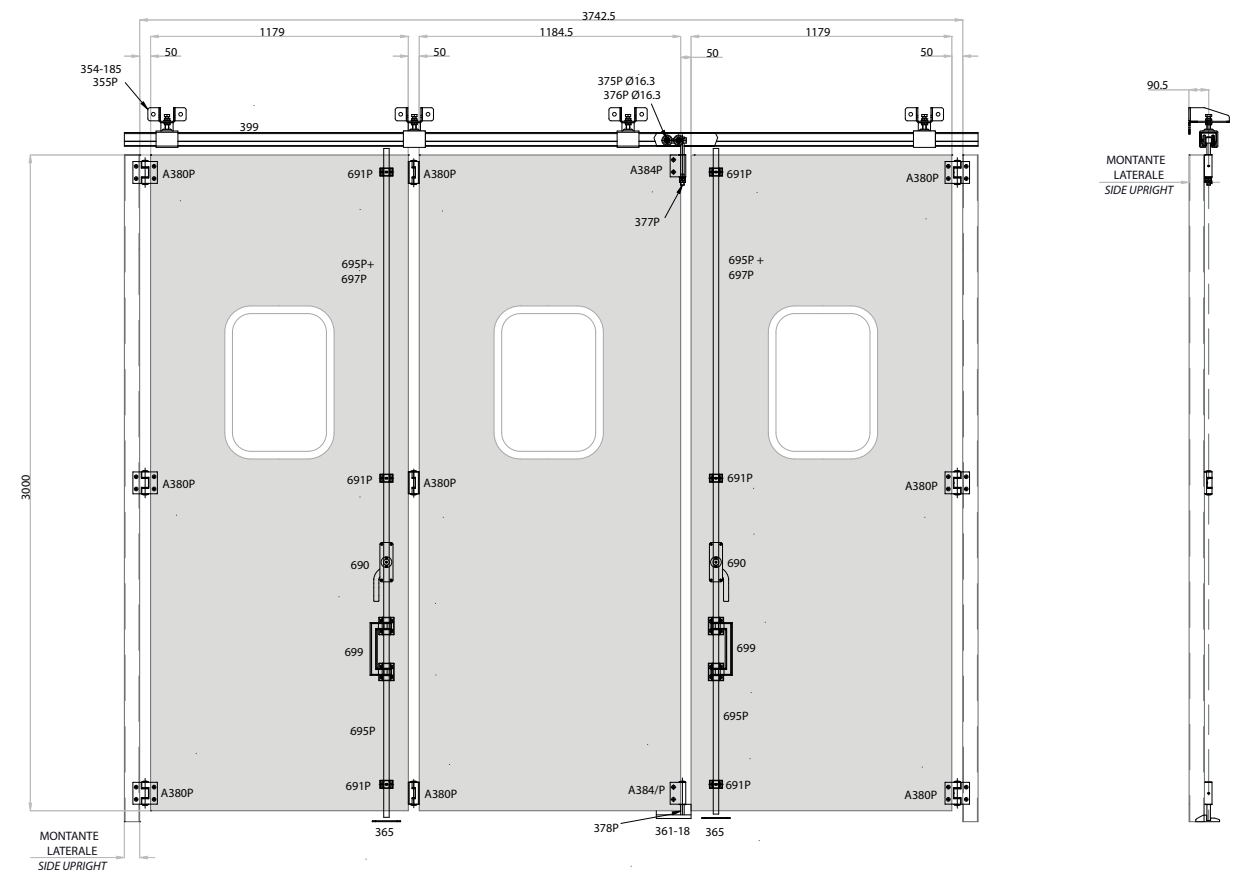

Schema con ante aperte/chiusa
Diagram with open/closed doors

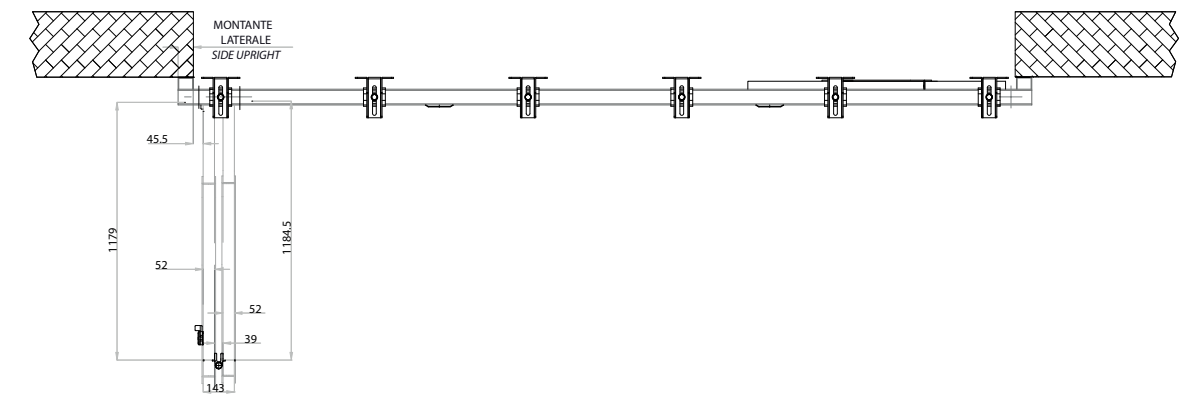

Particolari tecnici
Technical details

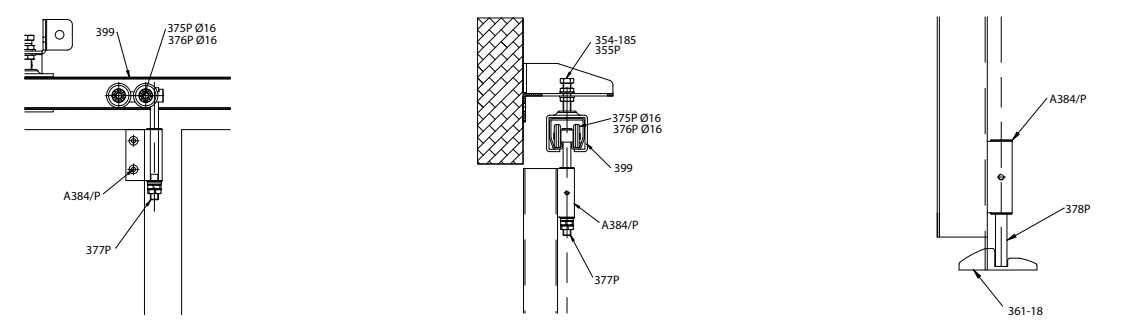

	ART.	DESCRIPTION	Box info Pcs per pack	PAG.
	399	Monorotaia superiore per carrelli 4 ruote piccola zincata Small galvanized upper guide for trolleys with four wheels / Rail supérieur pour chariots 4 galets petits zingués / Obere laufschiene für rollenapparate mit 4 rollen klein verzinkt / Monocamli superior pequeño galvanizado para carros con 4 ruedas / Верхний монорельс для тележек с 4 колесами малый оцинкованный	1 (6.0 m)	311
	354-185	Staffa regolabile a parete mm. 185 Adjustable wall rod 185 mm / Support réglable au mur mm. 185 / Regulierbarer wandbügel 185 mm / Placa regulable de pared 185 mm / Регулируемый настенный кронштейн мм 185	4	299
	355 P	Supporto guida regolabile Adjustable guide support / Support guide réglable / Regulierbare führung / Soporte guía regulable / Опора регулируемой направляющей	4	300
	375 P16 / 376 P16	Carrello piccolo a 4 ruote in acciaio / nylon Small steel trolley with four wheels - nylon / Chariot petit a 4 galets en acier - nylon / Rollenapparat klein mit 4 stahlrollen - nylonrollen / Carro pequeño con 4 ruedas de acero - nylon / Маленькая тележка с 4 нейлоновыми/стальными колесами	1	307
	690	Cariglione star piccolo Small star lever bolt / Cremona star petite / Treibriegel star klein / Falleba star pequeña / Малый болтовой рычаг star	1 DX + 1 SX	318
	699	Maniglione di trascinamento in nylon con passanti Nylon pull handle with guides / Poignée d'entraînement en nylon avec traversants / Nylongriff zum ziehen mit laschen / Tirador de nylon con puentes / Ручка из нейлона со сквозными направляющими	2	323
	695 P	Asta di chiusura tubolare 25x10 Closing tubular rod 25x10 / Tringle tubulaire de fermeture 25x10 / Rohrverschlussstange 25x10 / Varilla de cierre tubular 25x10 / Закрывающий стержень трубчатый 25x10	2 (1.20 m) + 2 (3.0 m)	322
	691 P	Passante per aste 30x10 Rod guide 30x10 / Traversant pour tringles 30x10 / Lasche für stangen 30x10 / Puente para varillas 30x10 / Сквозная направляющая для стержней 30x10	6	319
	365	Incontro per aste Floor strike plate for rods / Butoir pour tringles / Auftaufschuh für stangen / Encuentro para varillas / Упор для стержней	2	303
	361 P	Incontro a pavimento in alluminio Aluminium floor strike plate / Butoir au sol en aluminium / Bodenaufschuh aus aluminium / Encuentro de aluminio para el suelo / Алюминиевый напольный упор	1	302
	A380 P	Ceniera doppia piccola in alluminio con battute Small aluminium double hinge with steps / Paumelle double petite en aluminium avec butees / Doppelscharnier klein aus aluminium mit stützen / Pernio doble pequeño de aluminio con topes / Малый двойной шарнир из алюминия с упорами	9	327
	A384 P	Cerniera singola piccola in alluminio piana Small flat aluminium hinge / Paumelle simple petite en aluminium plate / Doppelscharnier gross aus aluminium mit stützen, ohne bolzen / Pernio pequeño de aluminio chato / Малый плоский одинарный шарнир из алюминия	2	328
	377 P	Perno superiore per carrelli Upper pin for trolleys / Pivot supérieur pour chariots / Oberer bolzen für rollenapparate / Perno superior para carros / Верхний штырь для тележек	1	307
	378 P	Perno inferiore regolabile Adjustable lower pin / Pivot inférieur réglable / Unterer bolzen Regulierbar / Perno inferior regulable / Нижний регулируемый штифт	1	305

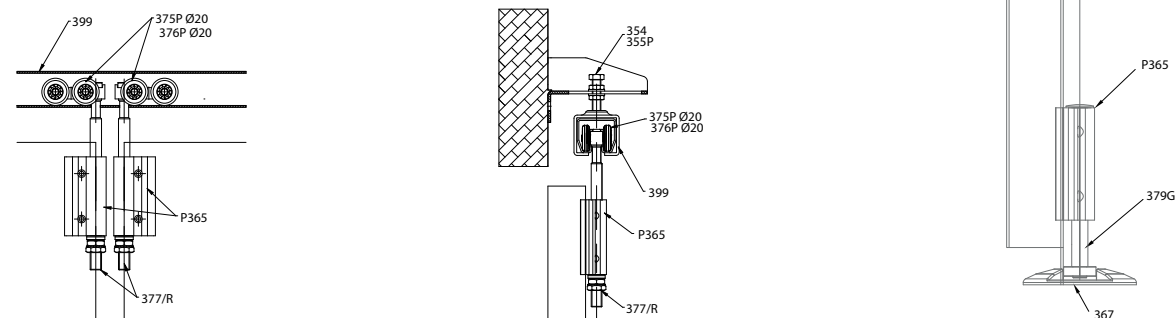
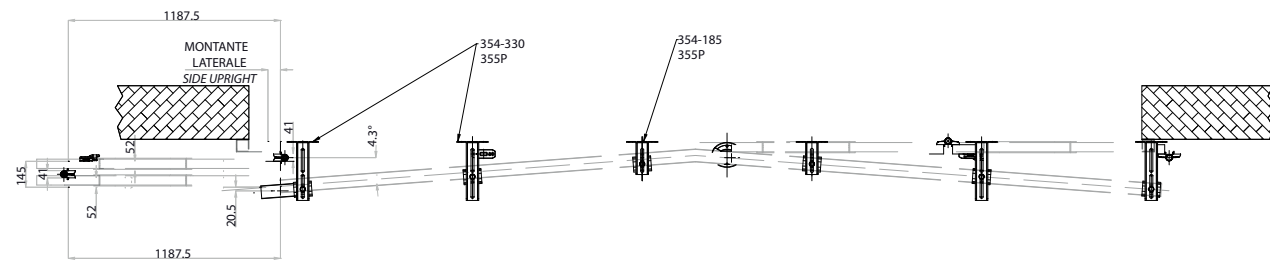
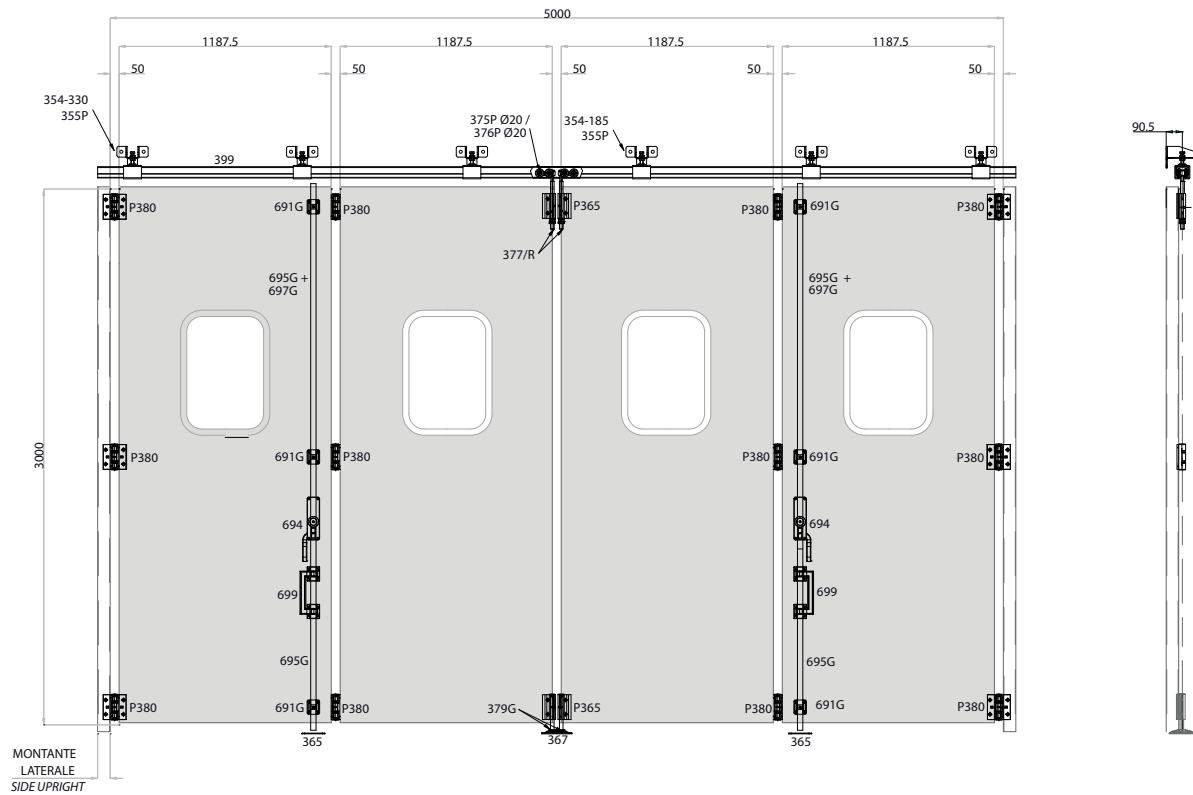

ART.	DESCRIPTION	Box info		PAG.
		Pcs per pack		
399	Monorotaia superiore per carrelli 4 ruote piccola zincata Small galvanized upper guide for trolleys with four wheels / Rail supérieur pour chariots 4 galets petits zingues / Obere laufschiene für rollenapparate mit 4 rollen klein verzinkt / Monocami superior pequeño galvanizado para carros con 4 ruedas / Верхний монорейль для тележек с 4 колесами малый оцинкованный	1	(6.0 m)	311
354-185	Staffa regolabile a parete mm. 185 Adjustable wall rod 185 mm. / Support réglable au mur mm. 185 / Regulierbarer wandbügel 185 mm / Placa regulable de pared 185 mm / Регулируемый настенный кронштейн мм 185	2		299
354-330	Staffa regolabile a parete mm. 330 Adjustable wall rod 330 mm. / Support c au mur mm. 330 / Regulierbarer wandbügel 330 mm / Placa regulable de pared 330 mm / Регулируемый настенный кронштейн мм 330	4		299
355 P	Supporto guida regolabile Adjustable guide support / Support guide réglable / Regulierbare führung / Soporte guía regulable / Опора регулируемой направляющей	6		300
375 P20 / 376 P20	Carrello piccolo a 4 ruote in acciaio / nylon Small steel trolley with four wheels - nylon / Chariot petit a 4 galets en acier - nylon / Rollenapparat klein mit 4 stahlrollen - nylonrollen / Carro pequeño con 4 ruedas de acero - nylon / Маленькая тележка с 4 нейлоновыми/стальными колесами	2		307
694 MC	Cariglione star grande Large star lever bolt / Cremona star grande / Treibriegel star gross / Falleba star grande / Большой болтовой рычаг star	1 DX + 1 SX		321
699	Maniglione di trascinamento in nylon con passanti Nylon pull handle with guides / Poignée d'entraînement en nylon avec traversants / Nylongriff zum ziehen mit laschen / Tirador de nylon con puentes / Ручка из нейлона со сквозными направляющими	2		323
695 G	Asta di chiusura tubolare 30x10 Closing tubular rod 30x10 / Tringle tubulaire de fermeture 30x10 / Rohrverschlussstange 30x10 / Varilla de cierre tubular 30x10 / Закрывающий стержень трубчатый 30x10	2 (1.20 m) + 2 (3.0 m)		322
691 G	Passante per aste 30x10 Rod guide 30x10 / Traversant pour tringles 30x10 / Lasche für stangen 30x10 / Puente para varillas 30x10 / Сквозная направляющая для стержней 30x10	6		319
365	Incontro per aste Floor strike plate for rods / Butoir pour tringles / Auftaufschuh für stangen / Encuentro para varillas / Упор для стержней	2		303
367	Incontro a pavimento in nylon nero, con rinforzo in acciaio Black nylon floor strike plate, with steel reinforcement / Butoir au sol en nylon noir, avec renfort en acier / Bodenaufschuh aus schwarzem nylon mit verstärkung aus stahl / Encuentro de nylon negro para suelo, con refuerzo de acero / Напольный упор из черного нейлона, со стальным укреплением	1		303
P380	Cerniera doppia in alluminio pressofuso con battute Die-cast aluminium double hinge with steps / Paumelle double en aluminium moulee avec butees / Doppelscharnier aus alu-druckguss flach, ohne bolzen / Pernio doble de aluminio fundido a presión con tope / Плоский двойной шарнир из литого алюминия с упорами	12		331
P365	Cerniera singola in alluminio pressofuso con battuta disassata Die-cast aluminium hinge with off-centre step / Paumelle simple en aluminium moulee avec butee desaxee / Einzel-scharnier gross aus aluminium mit stütze / Pernio de aluminio fundido a presión con tope descentrado / Одинарный шарнир из литого алюминия с упором, смещенный	4		329
377 R	Perno superiore ribassato Lowered upper pin / Pivot supérieur surbaisse / Oberer bolzen herabgesenkt / Perno superior rebajado / Верхний штырь пониженный	2		308
379 G 135	Perno inferiore regolabile con cuscinetto Adjustable lower pin with bearing / Pivot inférieur réglable avec roulement / Regulierbarer unterer bolzen mit kugellager / Perno inferior regulable con rodamiento / Нижний регулируемый штифт с подшипником	2		305
239	Tappo ammortizzatore ante Door leaf supporter / Embout d'amortissage vantaux / Stossdämpfer für türe / Amortiguador hojas / Амортизирующая пробка створки	2		295



Schema con ante chiuse
Diagram with closed doors

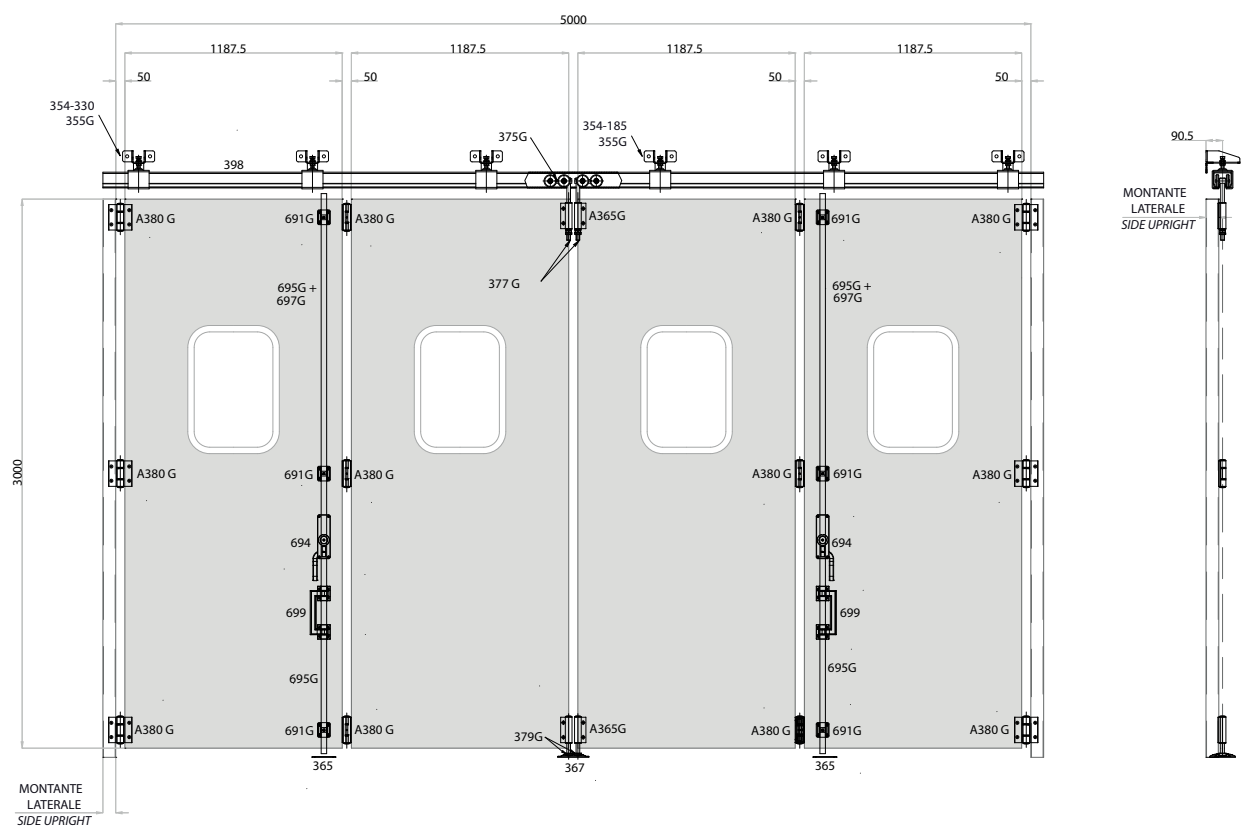

Schema con ante aperte/chiusa
Diagram with open/closed doors

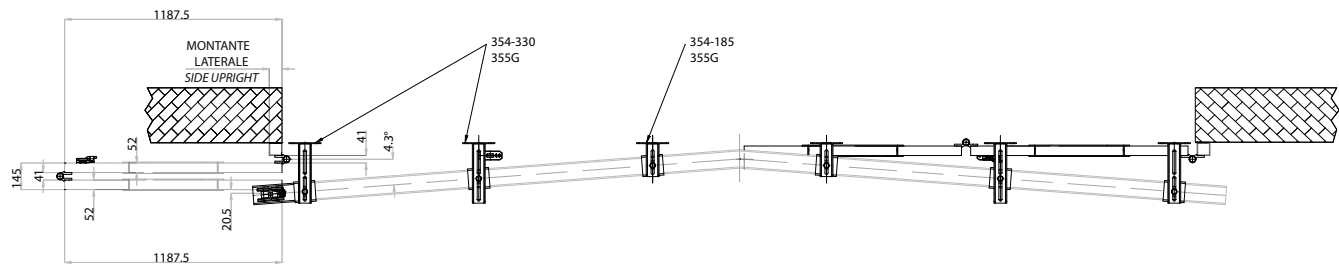

Particolari tecnici
Technical details

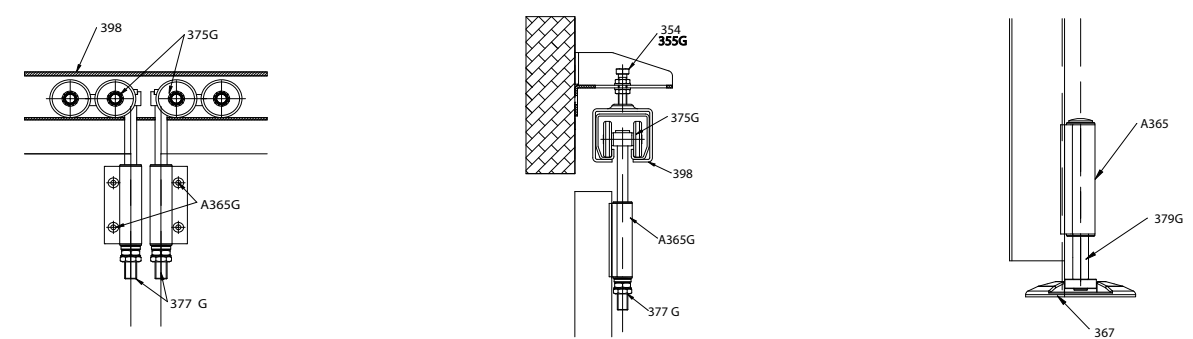

ART.	DESCRIPTION	Box info		PAG.
		Pcs per pack		
398	Monorotaia superiore per carrelli 4 ruote grande zincata Large galvanized upper guide for trolleys with four wheels / Rail supérieur pour chariots 4 galets grands zincés / Obere laufschiene für rollenapparate mit 4 rollen gross verzinkt / Monocarril superior grande galvanizado para carros con 4 ruedas / Верхний монорельс для тележек с 4 колесами большой оцинкованный	1	(6.0 m)	311
354-185	Staffa regolabile a parete mm. 185 Adjustable wall rod 185 mm. / Support réglable au mur mm. 185 / Regulierbarer wandbügel 185 mm / Placa regulable de pared 185 mm / Регулируемый настенный кронштейн мм 185	2		299
354-330	Staffa regolabile a parete mm. 330 Adjustable wall rod 330 mm. / Support c au mur mm. 330 / Regulierbarer wandbügel 330 mm / Placa regulable de pared 330 mm / Регулируемый настенный кронштейн мм 330	4		299
355 G	Supporto guida regolabile Adjustable guide support / Support guide réglable / Regulierbare führung / Soporte guía regulable / Опора регулируемой направляющей	6		300
375 G	Carrello grande a 4 ruote in acciaio per perno da mm. 20 Large steel trolley with four wheels for pin, 20 mm. / Chariot grand a 4 galets en acier pour pivot de mm. 20 / Rollenapparat gross mit 4 stahlrollen für bolzen 20 mm / Carro grande con 4 ruedas de acero para perno de 20 mm / Большая тележка 4 стальными колесами для штифта мм 20	2		307
694 MC	Cariglione star grande Large star lever bolt / Cremona star grande / Treibriegel star gross / Falleba star grande / Большой болтовой рычаг star	1DX + 1SX		321
699	Maniglione di trascinamento in nylon con passanti Nylon pull handle with guides / Poignée d'entraînement en nylon avec traversants / Nylongriff zum ziehen mit laschen / Tirador de nylon con puentes / Ручка из нейлона со сквозными направляющими	2		323
695 G	Asta di chiusura tubolare 30x10 Closing tubular rod 30x10 / Tringle tubulaire de fermeture 30x10 / Rohrverschlussstange 30x10 / Varilla de cierre tubular 30x10 / Закрывающий стержень трубчатый 30x10	2 (1.20 m) + 2 (3.0 m)		322
691 G	Passante per aste 30x10 Rod guide 30x10 / Traversant pour tringles 30x10 / Lasche für stangen 30x10 / Puente para varillas 30x10 / Сквозная направляющая для стержней 30x10	6		319
365	Incontro per aste Floor strike plate for rods / Butoir pour tringles / Auftaufschuh für stangen / Encuentro para varillas / Упор для стержней	2		303
367	Incontro a pavimento in nylon nero, con rinforzo in acciaio Black nylon floor strike plate, with steel reinforcement / Butoir au sol en nylon noir, avec renfort en acier / Bodenaufschuh aus schwarzem nylon mit verstärkung aus stahl / Encuentro de nylon negro para suelo, con refuerzo de acero / Напольный упор из черного нейлона, со стальным укреплением	1		303
A380 G	Cerniera doppia grande in alluminio con battute Large aluminium double hinge with steps / Paumelle double grande en aluminium avec boutes / Doppelscharnier klein aus aluminium flach, ohne bolzen / Pernio doble grande de aluminio con topes / Большой двойной шарнир из алюминия с упорами	12		326
377 G 330	Perno superiore per carrelli Upper pin for trolleys / Pivot supérieur pour chariots / Oberer bolzen für rollenapparate / Perno superior para carros / Верхний штырь для тележек	2		307
379 G 135	Perno inferiore regolabile con cuscinetto Adjustable lower pin with bearing / Pivot inférieur réglable avec roulement / Regulierbarer unterer bolzen mit kugellager / Perno inferior regulable con rodamiento / Нижний регулируемый штифт с подшипником	2		305
239	Tappo ammortizzatore ante Door leaf suppperper / Embout d'amortissage vantaux / Stossdämpfer für türe / Amortiguador hojas / Амортизирующая пробка створки	2		295

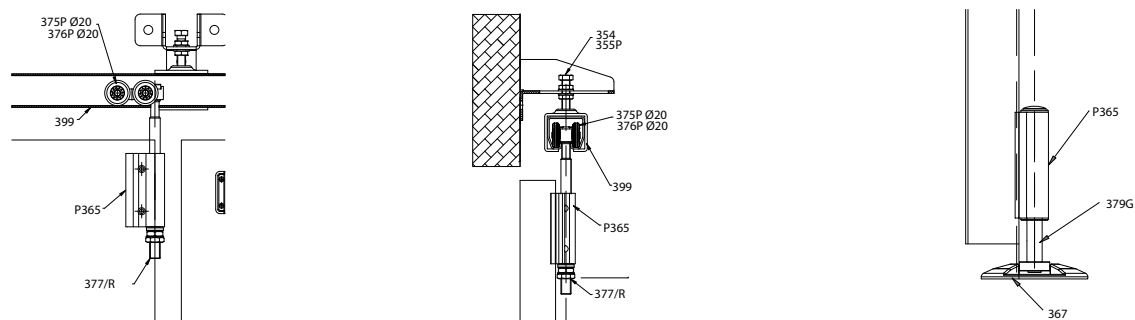
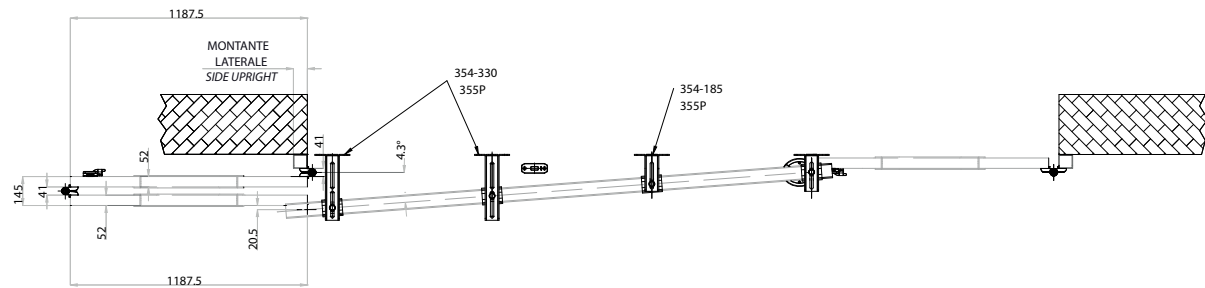
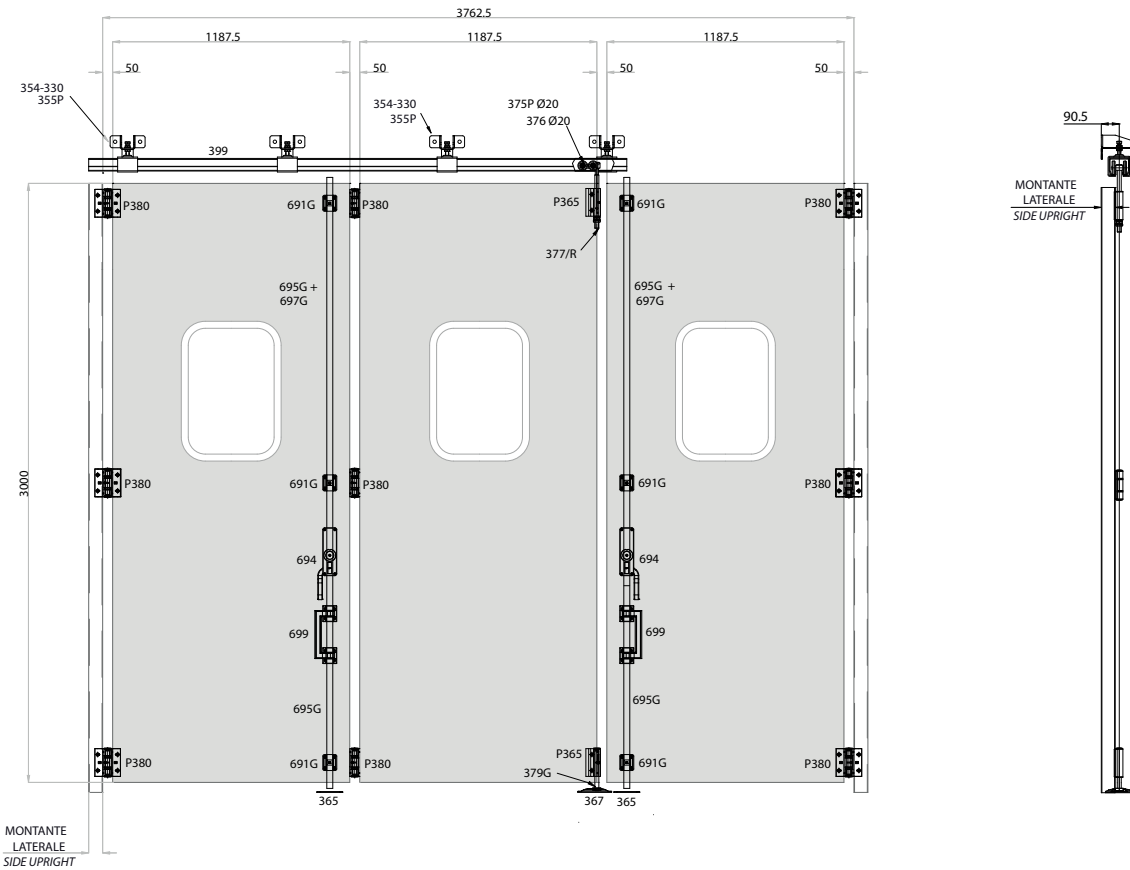

	ART.	DESCRIPTION	Box info Pcs per pack	PAG.
	399	Monorotaia superiore per carrelli 4 ruote piccola zincata Small galvanized upper guide for trolleys with four wheels / Rail supérieur pour chariots 4 galets petits zingues / Obere Laufschiene für rollenapparate mit 4 rollen klein verzinkt / Monocami superior pequeño galvanizado para carros con 4 ruedas / Верхний монорейль для тележек с 4 колесами малый оцинкованный	1 (3.0 m)	311
	354-185	Staffa regolabile a parete mm. 185 Adjustable wall rod 185 mm / Support réglable au mur mm. 185 / Regulierbarer wandbügel 185 mm / Placa regulable de pared 185 mm / Регулируемый настенный кронштейн мм 185	2	299
	354-330	Staffa regolabile a parete mm. 330 Adjustable wall rod 330 mm / Support c au mur mm. 330 / Regulierbarer wandbügel 330 mm / Placa regulable de pared 330 mm / Регулируемый настенный кронштейн мм 330	2	299
	355 P	Supporto guida regolabile Adjustable guide support / Support guide réglable / Regulierbare führung / Soporte guía regulable / Опора регулируемой направляющей	4	300
	375 P20 / 376 P20	Carrello piccolo a 4 ruote in acciaio / nylon Small steel trolley with four wheels - nylon / Chariot petit à 4 galets en acier - nylon / Rollenapparat klein mit 4 stahlrollen - nylonrollen / Carro pequeño con 4 ruedas de acero - nylon / Маленькая тележка с 4 нейлоновыми/стальными колесами	1	307
	694 MC	Cariglione star grande Large star lever bolt / Cremona star grande / Treibriegel star gross / Falleba star grande / Большой болтовой рычаг star	1DX + 1SX	321
	699	Maniglione di trascinnamento in nylon con passanti Nylon pull handle with guides / Poignée d'entraînement en nylon avec traversants / Nylongriff zum ziehen mit laschen / Tirador de nylon con puentes / Ручка из нейлона со сквозными направляющими	2	323
	695 G	Asta di chiusura tubolare 30x10 Closing tubular rod 30x10 / Tringle tubulaire de fermeture 30x10 / Rohrverschlussstange 30x10 / Varilla de cierre tubular 30x10 / Закрывающий стержень трубчатый 30x10	2 (1.20 m) + 2 (3.0 m)	322
	691 G	Passante per aste 30x10 Rod guide 30x10 / Traversant pour tringles 30x10 / Lasche für stangen 30x10 / Puente para varillas 30x10 / Сквозная направляющая для стержней 30x10	6	319
	365	Incontro per aste Floor strike plate for rods / Butoir pour tringles / Auftaufschuh für stangen / Encuentro para varillas / Упор для стержней	2	303
	367	Incontro a pavimento in nylon nero, con rinforzo in acciaio Black nylon floor strike plate, with steel reinforcement / Butoir au sol en nylon noir, avec renfort en acier / Bodenaufschuh aus schwarzem nylon mit verstärkung aus stahl / Encuentro de nylon negro para suelo, con refuerzo de acero / Натольный упор из черного нейлона, со стальным укреплением	1	303
	P380	Cerniera doppia in alluminio pressofuso con battute Die-cast aluminium double hinge with steps / Paumelle double en aluminium moulee avec butees / Doppelscharnier aus alu-druckguss flach, ohne bolzen / Pernio doble de aluminio fundido a presión con tope / Плоский двойной шарнир из литого алюминия с упорами	9	331
	P365	Cerniera singola in alluminio pressofuso con battuta disassata Die-cast aluminium hinge with off-centre step / Paumelle simple en aluminium moulee avec butee desaxee / Einzel-scharnier gross aus aluminium mit stütze / Pernio de aluminio fundido a presión con tope descentrado / Одинарный шарнир из литого алюминия с упором, смещенный	2	329
	377 R	Perno superiore ribassato Lowered upper pin / Pivot supérieur surbaisse / Oberer bolzen herabgesenkt / Perno superior rebajado / Верхний штырь пониженный	1	308
	379 G 135	Perno inferiore regolabile con cuscinetto Adjustable lower pin with bearing / Pivot inférieur réglable avec roulement / Regulierbarer unterer bolzen mit kugellager / Perno inferior regulable con rodamiento / Нижний регулируемый штыфт с подшипником	1	305
	239	Tappo ammortizzatore ante Door leaf supporter / Embout d'amortissage vantaux / Stossdämpfer für türe / Amortiguador hojas / Амортизирующая пробка створки	1	295

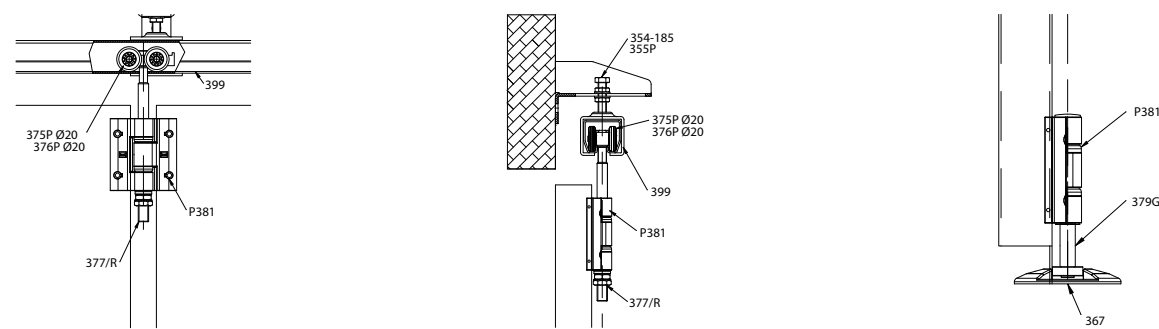
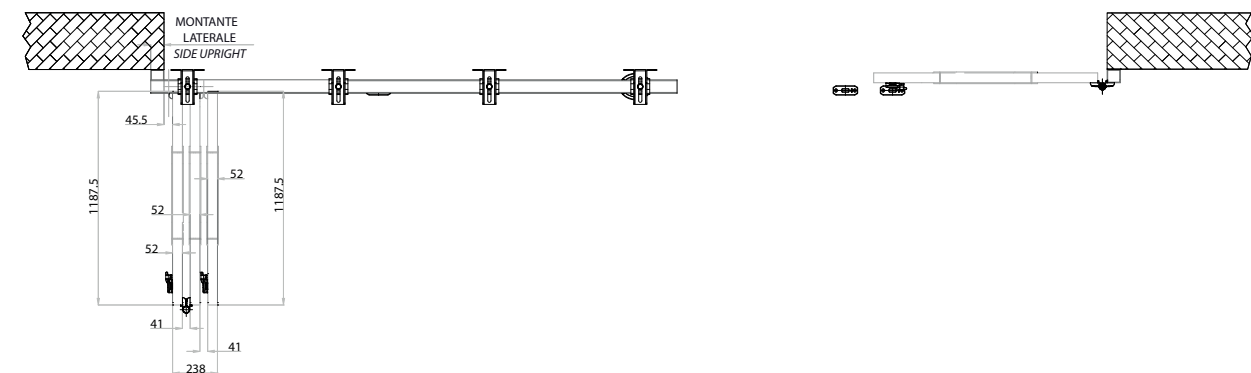
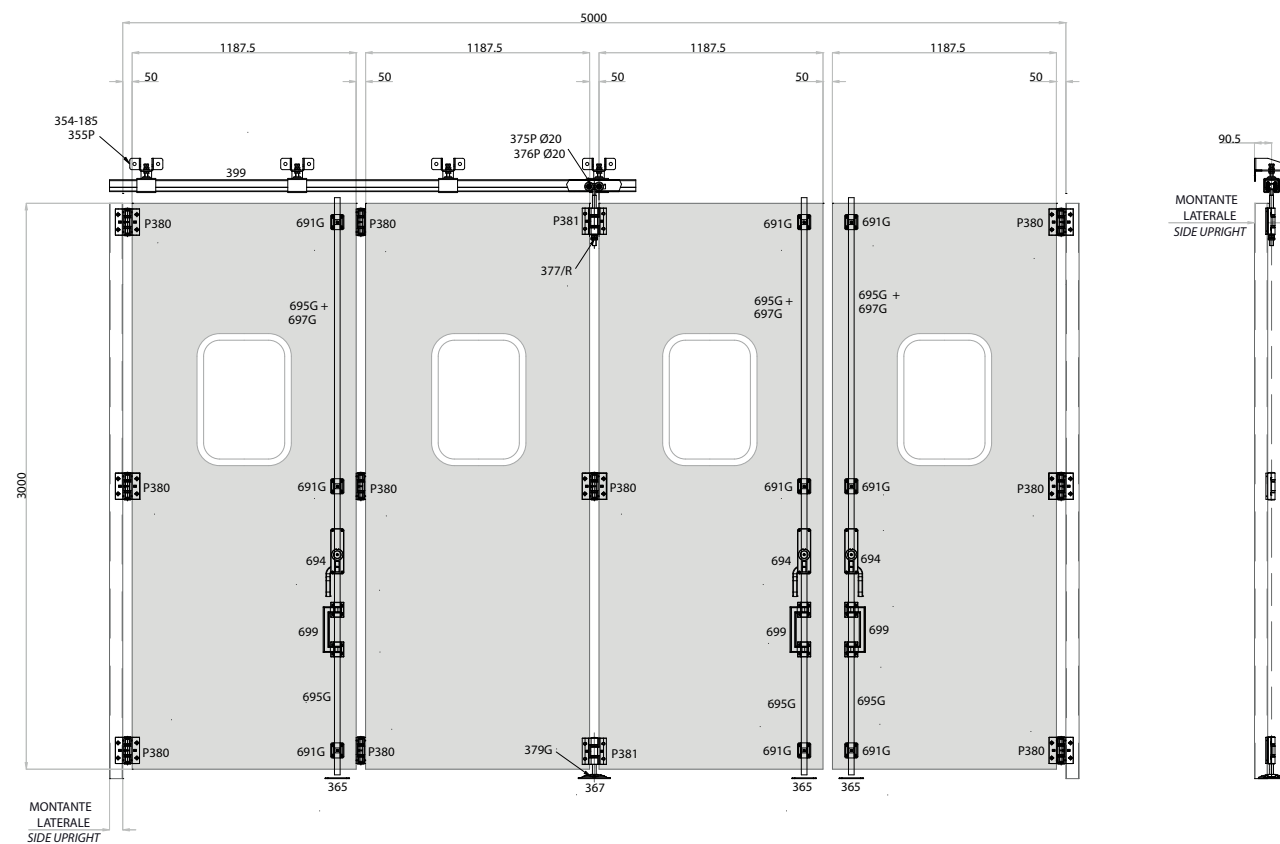

	ART.	DESCRIPTION	Box info Pcs per pack	PAG.
	399	Monorotaia superiore per carrelli 4 ruote piccola zincata Small galvanized upper guide for trolleys with four wheels / Rail supérieur pour chariots 4 galets petits zingues / Obere laufschiene für rollenapparate mit 4 rollen klein verzinkt / Monocami superior pequeño galvanizado para carros con 4 ruedas / Верхний монорельс для тележек с 4 колесами малый оцинкованный	1 (3.0 m)	311
	354-185	Staffa regolabile a parete mm. 185 Adjustable wall rod 185 mm. / Support réglable au mur mm. 185 / Regulierbarer wandbügel 185 mm / Placa regulable de pared 185 mm / Регулируемый настенный кронштейн мм 185	4	299
	355 P	Supporto guida regolabile Adjustable guide support / Support guide réglable / Regulierbare führung / Soporte guía regulable / Опора регулируемой направляющей	4	300
	375 P20 / 376 P20	Carrello piccolo a 4 ruote in acciaio / nylon Small steel trolley with four wheels - nylon / Chariot petit a 4 galets en acier - nylon / Rollenapparat klein mit 4 stahlrollen - nylonrollen / Carro pequeño con 4 ruedas de acero - nylon / Маленькая тележка с 4 нейлоновыми/стальными колесами	1	307
	694 MC	Cariglione star grande Large star lever bolt / Cremona star grande / Treibriegel star gross / Falleba star grande / Большой болтовой рычаг star	1 DX + 1 SX	321
	699	Maniglione di trascinamento in nylon con passanti Nylon pull handle with guides / Poignée d'entraînement en nylon avec traversants / Nylongriff zum ziehen mit laschen / Tirador de nylon con puentes / Ручка из нейлона со сквозными направляющими	3	323
	695 G	Asta di chiusura tubolare 30x10 Closing tubular rod 30x10 / Tringle tubulaire de fermeture 30x10 / Rohrverschlussstange 30x10 / Varilla de cierre tubular 30x10 / Закрывающий стержень трубчатый 30x10	3 (1.20 m) + 3 (3.0 m)	322
	691 G	Passante per aste 30x10 Rod guide 30x10 / Traversant pour tringles 30x10 / Lasche für stangen 30x10 / Puente para varillas 30x10 / Сквозная направляющая для стержней 30x10	9	319
	365	Incontro per aste Floor strike plate for rods / Butoir pour tringles / Auftaufschuh für stangen / Encuentro para varillas / Упор для стержней	3	303
	367	Incontro a pavimento in nylon nero, con rinforzo in acciaio Black nylon floor strike plate, with steel reinforcement / Butoir au sol en nylon noir, avec renfort en acier / Bodenaufschuh aus schwarzem nylon mit verstärkung aus stahl / Encuentro de nylon negro para suelo, con refuerzo de acero / Напольный упор из черного нейлона, со стальным укреплением	1	303
	P380	Cerniera doppia in alluminio pressofuso con battute Die-cast aluminium double hinge with steps / Paumelle double en aluminium moulée avec butees / Doppelscharnier aus alu-druckguss flach, ohne bolzen / Perno doble de aluminio fundido a presión con topes / Плоский двойной шарнир из литого алюминия с упорами	10	331
	P381	Cerniera doppia in alluminio pressofuso con battute, senza perno Die-cast aluminium double hinge with steps, without pin / Paumelle double en aluminium moulée avec butees, sans pivot / Doppelscharnier aus alu-druckguss mit stützen / Perno doble de aluminio fundido a presión con topes, sin eje / Двойной шарнир из литого алюминия с упорами без штифта	2	329
	377 R	Perno superiore ribassato Lowered upper pin / Pivot supérieur surbaisse / Oberer bolzen herabgesenkt / Perno superior rebajado / Верхний штырь пониженный	1	308
	379 G 135	Perno inferiore regolabile con cuscinetto Adjustable lower pin with bearing / Pivot inférieur réglable avec roulement / Regulierbarer unterer bolzen mit kugellager / Perno inferior regulable con rodamiento / Нижний регулируемый штифт с подшипником	1	305
	239	Tappo ammortizzatore ante Door leaf supporter / Embout d'amortissage vantaux / Stossdämpfer für türe / Amortiguador hojas / Амортизирующая пробка створки	2	295

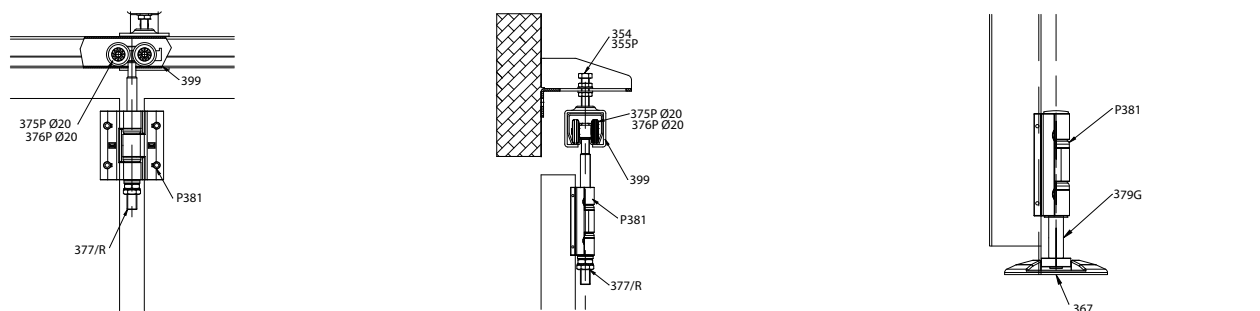
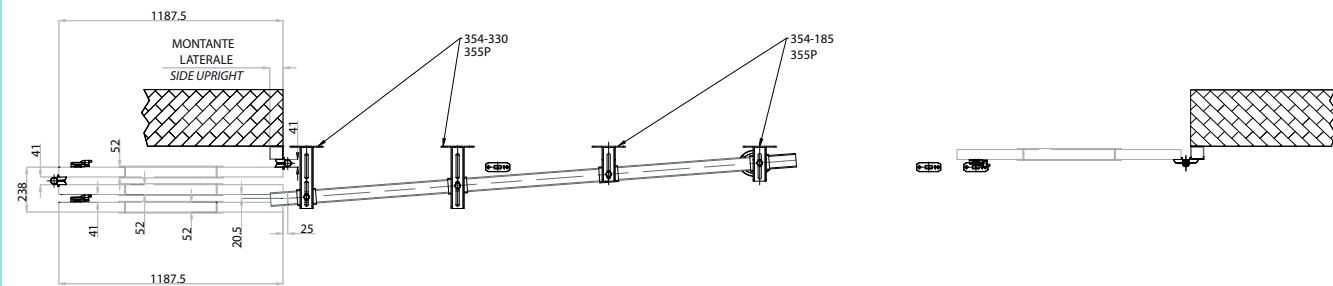
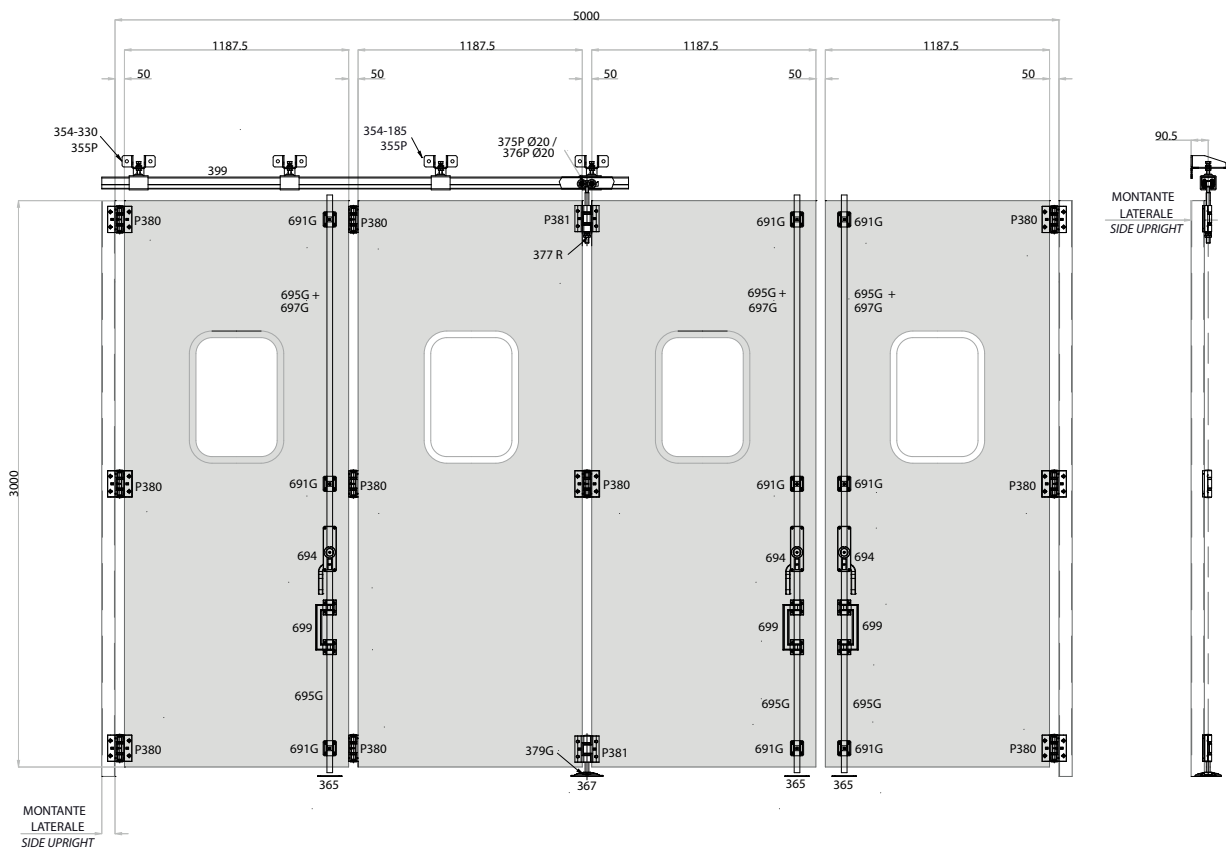

ART.	DESCRIPTION	Box info	PAG.
		Pcs per pack	
399	Monorotaia superiore per carrelli 4 ruote piccola zincata Small galvanized upper guide for trolleys with four wheels / Rail supérieur pour chariots 4 galets petits zingues / Obere Laufschiene für rollenapparate mit 4 rollen klein verzinkt / Monocarril superior pequeño galvanizado para carros con 4 ruedas / Верхний монорейль для тележек с 4 колесами малый оцинкованный	1 (3.0 m)	311
354-185	Staffa regolabile a parete mm. 185 Adjustable wall rod 185 mm. / Support réglable au mur mm. 185 / Regulierbarer wandbügel 185 mm / Placa regulable de pared 185 mm / Регулируемый настенный кронштейн мм 185	2	299
354-330	Staffa regolabile a parete mm. 330 Adjustable wall rod 330 mm. / Support c au mur mm. 330 / Regulierbarer wandbügel 330 mm / Placa regulable de pared 330 mm / Регулируемый настенный кронштейн мм 330	2	299
355 P	Supporto guida regolabile Adjustable guide support / Support guide réglable / Regulierbare führung / Soporte guía regulable / Опора регулируемой направляющей	4	300
375 P20 / 376 P20	Carrello piccolo a 4 ruote in acciaio / nylon Small steel trolley with four wheels - nylon / Chariot petit a 4 galets en acier - nylon / Rollenapparat klein mit 4 stahlrollen - nylonrollen / Carro pequeño con 4 ruedas de acero - nylon / Маленькая тележка с 4 нейлоновыми/стальными колесами	1	307
694 MC	Cariglione star grande Large star lever bolt / Cremona star grande / Treibriegel star gross / Falleba star grande / Большой болтовой рычаг star	1 DX + 1 SX	321
699	Maniglione di trascinamento in nylon con passanti Nylon pull handle with guides / Poignée d'entraînement en nylon avec traversants / Nylongriff zum ziehen mit laschen / Tirador de nylon con puentes / Ручка из нейлона со сквозными направляющими	3	323
695 G	Asta di chiusura tubolare 30x10 Closing tubular rod 30x10 / Tringle tubulaire de fermeture 30x10 / Rohrverschlussstange 30x10 / Varilla de cierre tubular 30x10 / Закрывающий стержень трубчатый 30x10	3 (1.20 m) + 3 (3.0 m)	322
691 G	Passante per aste 30x10 Rod guide 30x10 / Traversant pour tringles 30x10 / Lasche für stangen 30x10 / Puente para varillas 30x10 / Сквозная направляющая для стержней 30x10	9	319
365	Incontro per aste Floor strike plate for rods / Butoir pour tringles / Auftaufschuh für stangen / Encuentro para varillas / Упор для стержней	3	303
367	Incontro a pavimento in nylon nero, con rinforzo in acciaio Black nylon floor strike plate, with steel reinforcement / Butoir au sol en nylon noir, avec renfort en acier / Bodenaufschuh aus schwarzem nylon mit verstärkung aus stahl / Encuentro de nylon negro para suelo, con refuerzo de acero / Напольный упор из черного нейлона, со стальным укреплением	1	303
P380	Cerniera doppia in alluminio pressofuso con battute Die-cast aluminium double hinge with steps / Paumelle double en aluminium moulée avec butées / Doppelscharnier aus alu-druckguss flach, ohne bolzen / Pernio doble de aluminio fundido a presión con topes / Плоский двойной шарнир из литого алюминия с упорами	10	331
P381	Cerniera doppia in alluminio pressofuso con battute, senza perno Die-cast aluminium double hinge, without pin / Paumelle double en aluminium moulée avec butées, sans pivot / Doppelscharnier aus alu-druckguss mit stützen / Pernio doble de aluminio fundido a presión con topes, sin eje / Двойной шарнир из литого алюминия с упорами без штифта	2	329
377 R	Perno superiore ribassato Lowered upper pin / Pivot supérieur surbaisse / Oberer bolzen herabgesenkt / Perno superior rebajado / Верхний штырь пониженный	1	308
379 G 135	Perno inferiore regolabile con cuscinetto Adjustable lower pin with bearing / Pivot inférieur réglable avec roulement / Regulierbarer unterer bolzen mit kugellager / Perno inferior regulable con rodamiento / Нижний регулируемый штифт с подшипником	1	305
239	Tappo ammortizzatore ante Door leaf supporter / Embout d'amortissage vantaux / Stossdämpfer für türe / Amortiguador hojas / Амортизирующая пробка створки	2	295

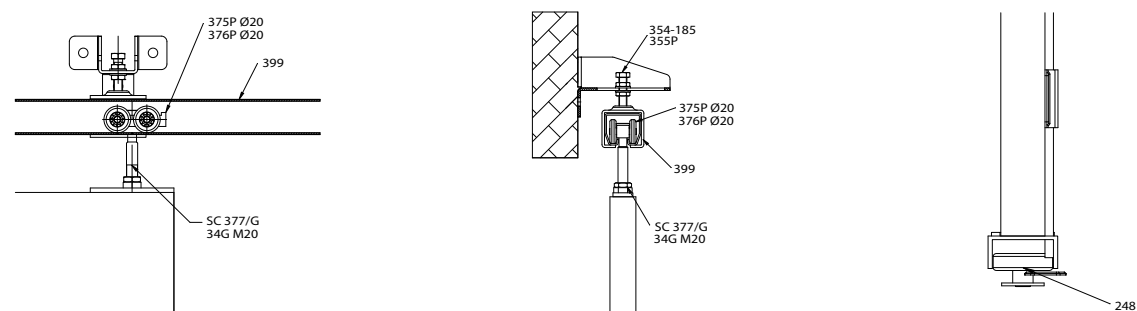
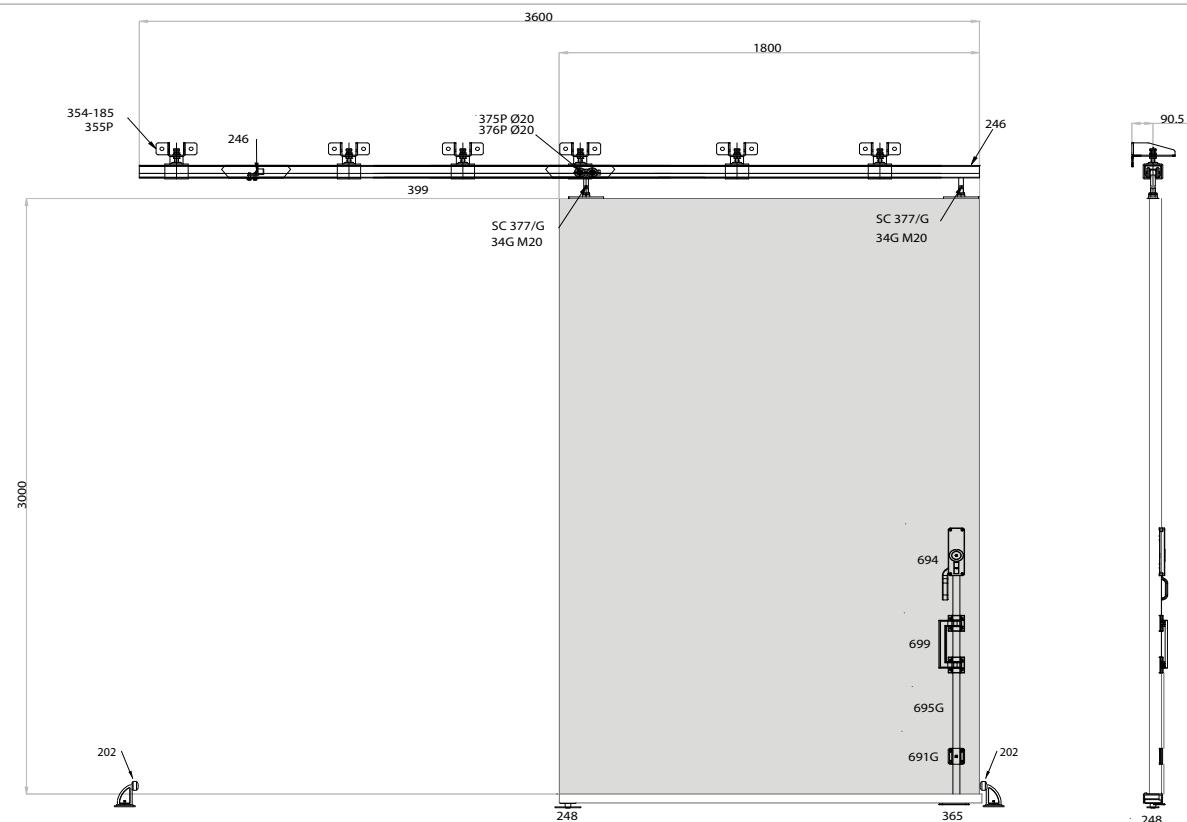

	ART.	DESCRIPTION	Box info	PAG.
			Pcs per pack	
	399	Monorotaia superiore per carrelli 4 ruote piccola zincata Small galvanized upper guide for trolleys with four wheels / Rail supérieur pour chariots 4 galets petits zingues / Obere laufschiene für rollenapparate mit 4 rollen klein verzinkt / Monocaril superior pequeño galvanizado para carros con 4 ruedas / Верхний монорельс для тележек с 4 колесами малый оцинкованный	1 (6.0 m)	311
	354-185	Staffa regolabile a parete mm. 185 Adjustable wall rod 185 mm / Support réglable au mur mm. 185 / Regulierbarer wandbügel 185 mm / Placa regulable de pared 185 mm / Регулируемый настенный кронштейн мм 185	6	299
	355 P	Supporto guida regolabile Adjustable guide support / Support guide réglable / Regulierbare führung / Soporte guía regulable / Опора регулируемой направляющей	6	300
	375 P20 / 376 P20	Carrello piccolo a 4 ruote in acciaio / nylon Small steel trolley with four wheels - nylon / Chariot petit a 4 galets en acier - nylon / Rollenapparat klein mit 4 stahlrollen - nylonrollen / Carro pequeño con 4 ruedas de acero - nylon / Маленькая тележка с 4 нейлоновыми/стальными колесами	2	307
	694 MC	Cariglione star grande Large star lever bolt / Cremona star grande / Treibriegel star gross / Falleba star grande / Большой болтовой рычаг star	1 SX	321
	699	Maniglione di trascinamento in nylon con passanti Nylon pull handle with guides / Poignée d'entraînement en nylon avec traversants / Nylongriff zum ziehen mit laschen / Tirador de nylon con puentes / Ручка из нейлона со сквозными направляющими	1	323
	695 G	Asta di chiusura tubolare 30x10 Closing tubular rod 30x10 / Tringle tubulaire de fermeture 30x10 / Rohrverschlussstange 30x10 / Varilla de cierre tubular 30x10 / Закрывающий стержень трубчатый 30x10	1 (1.20 m)	322
	691 G	Passante per aste 30x10 Rod guide 30x10 / Traversant pour tringles 30x10 / Lasche für stangen 30x10 / Puente para varillas 30x10 / Сквозная направляющая для стержней 30x10	1	319
	365	Incontro per aste Floor strike plate for rods / Butoir pour tringles / Auftaufschuh für stangen / Encuentro para varillas / Упор для стержней	1	303
	34 G	Piastra girevole con cuscinetto per carrelli Turning plate with bearing for trolleys / Platine pivotante avec roulement pour chariots / Schwenkplatte mit kugellager für rollenapparate / Placa giratoria con rodamiento para carros / Поворотная пластина с подшипником для тележек	2	290
	377 G-SC	Perno superiore per scorrevoli zincato Galvanized upper pin for sliding doors / Pivot supérieur pour portail coulissant zingue / Oberer bolzen für schiebetüren verzinkt / Perno superior para puerta corredera galvanizado / Верхний штырь для передвижения оцинкованный	2	308
	248	Guida per portoni scorrevoli Guide for sliding doors / Guide pour portails coulissants / Führung für schiebetüren / Guía para portones de corredera / Направляющая для раздвижных дверей	1	296
	246	Battente finecorsa per monorotaie art. 398/399 End-supper for guides art. 398/399 / Butée de fin de course pour rails art. 398/399 / Letzter türflügel für laufschiene art. 398/399 / Tope para monocaril art. 398/399 / Стопор конца хода для монорельсов art. 398/399	2	295
	202	Arresto di fine corsa con base a fissare Runaway stop to be screwed / Boutoir de fin de course avec base à visser / Torendpuffer mit befestigungsplatte zum anschrauben / Tope de final de carrera con base para fijar / Стопор конца хода с приклепываемым основанием	2	77



Schema con ante chiuse
Diagram with closed doors

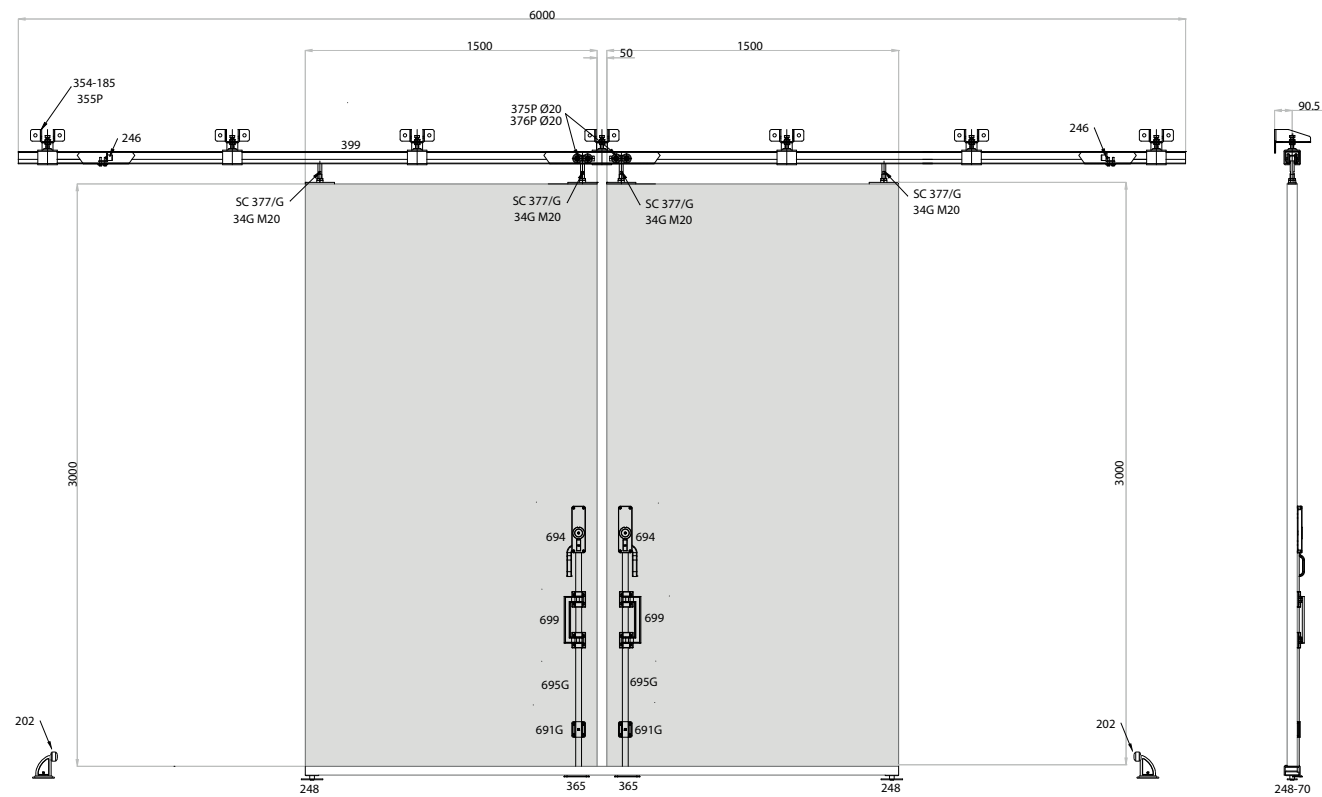

Schema con ante aperte/chiusa
Diagram with open/closed doors

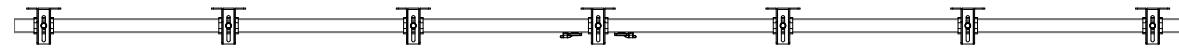

Particolari tecnici
Technical details

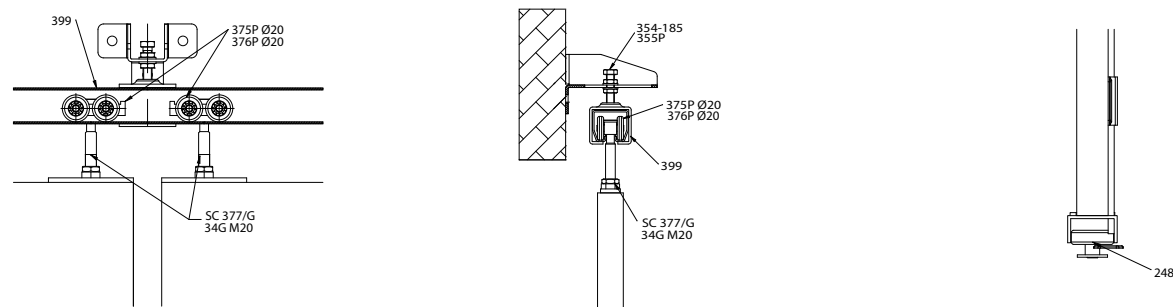

	ART.	DESCRIPTION	Box info	PAG.
			Pcs per pack	
	399	Monorotaia superiore per carrelli 4 ruote piccola zincata Small galvanized upper guide for trolleys with four wheels / Rail supérieur pour chariots 4 galets petits zingues / Obere laufschiene für rollenapparate mit 4 rollen klein verzinkt / Monocarri superior pequeño galvanizado para carros con 4 ruedas / Верхний монорельс для тележек с 4 колесами малый оцинкованный	1 (6.0 m)	311
	354-185	Staffa regolabile a parete mm. 185 Adjustable wall rod 185 mm / Support réglable au mur mm. 185 / Regulierbarer wandbügel 185 mm / Placa regulable de pared 185 mm / Регулируемый настенный кронштейн мм 185	7	299
	355 P/G	Supporto guida regolabile Adjustable guide support / Support guide réglable / Regulierbare führung / Soporte guía regulable / Опора регулируемой направляющей	7	300
	375 P20 / 376 P20	Carrello piccolo a 4 ruote in acciaio / nylon Small steel trolley with four wheels - nylon / Chariot petit a 4 galets en acier - nylon / Rollenapparat klein mit 4 stahlrollen - nylonrollen / Carro pequeño con 4 ruedas de acero - nylon / Маленькая тележка с 4 нейлоновыми/стальными колесами	4	307
	694 MC	Cariglione star grande Large star lever bolt / Cremona star grande / Treibriegel star gross / Falleba star grande / Большой болтовой рычаг star	1 DX + 1 SX	321
	699	Maniglione di trascinamento in nylon con passanti Nylon pull handle with guides / Poignée d'entraînement en nylon avec traversants / Nylongriff zum ziehen mit laschen / Tirador de nylon con puentes / Ручка из нейлона со сквозными направляющими	2	323
	695 G	Asta di chiusura tubolare 30x10 Closing tubular rod 30x10 / Tringle tubulaire de fermeture 30x10 / Rohrschlussstange 30x10 / Varilla de cierre tubular 30x10 / Закрывающий стержень трубчатый 30x10	2 (1.20 m)	322
	691 G	Passante per aste 30x10 Rod guide 30x10 / Traversant pour tringles 30x10 / Lasche für stangen 30x10 / Puente para varillas 30x10 / Сквозная направляющая для стержней 30x10	2	319
	365	Incontro per aste Floor strike plate for rods / Butoir pour tringles / Auftaufschuh für stangen / Encuentro para varillas / Упор для стержней	2	303
	34 G	Piastra girevole con cuscinetto per carrelli Turning plate with bearing for trolleys / Platine pivotante avec roulement pour chariots / Schwenkplatte mit kugellager für rollenapparate / Placa giratoria con rodamiento para carros / Поворотная пластина с подшипником для тележек	4	290
	377 G-SC	Perno superiore per scorrevoli zincato Galvanized upper pin for sliding doors / Pivot supérieur pour portail coulissant zingue / Oberer bolzen für schiebetüren verzinkt / Perno superior para puerta corredera galvanizado / Верхний штырь для передвижения оцинкованный	4	308
	248	Guida per portoni scorrevoli Guide for sliding doors / Guide pour portails coulissants / Führung für schiebetüren / Guía para portones de corredera / Направляющая для раздвижных дверей	2	296
	246	Battente finecorsa per monorotaie art. 398/399 End-supper for guides art. 398/399 / Butee de fin de course pour rails art. 398/399 / Letzter türflügel für laufschiene art. 398/399 / Tope para monocarri art. 398/399 / Стопор конца хода для монорельсов art. 398/399	2	295
	202	Arresto di fine corsa con base a fissare Runaway stop to be screwed / Butoir de fin de course avec base à visser / Torendpuffer mit befestigungsplatte zum anschrauben / Tope de final de carrera con base para fijar / Стопор конца хода с приклепываемым основанием	2	77



Schema con ante chiuse
Diagram with closed doors

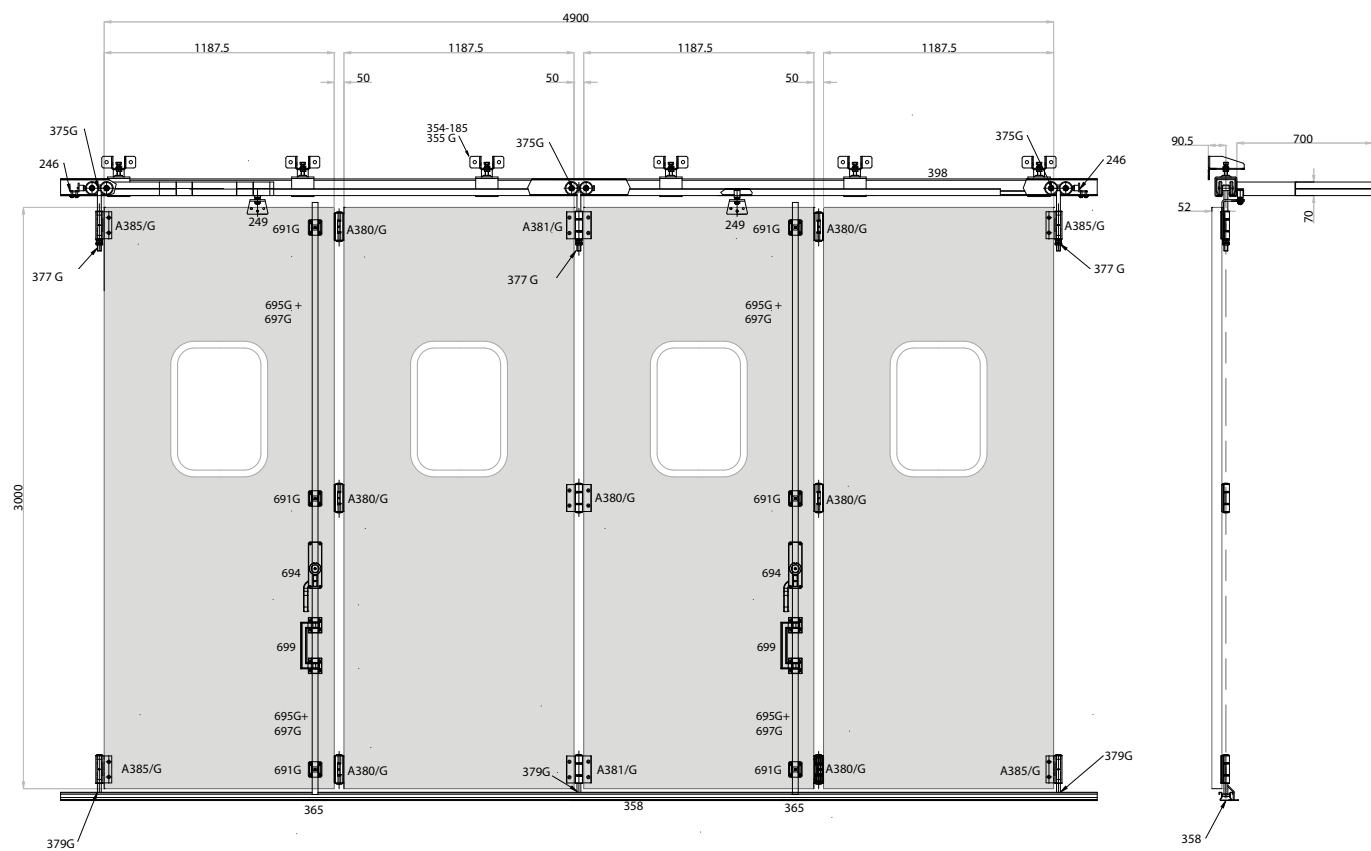

Schema con ante aperte/chiusa
Diagram with open/closed doors

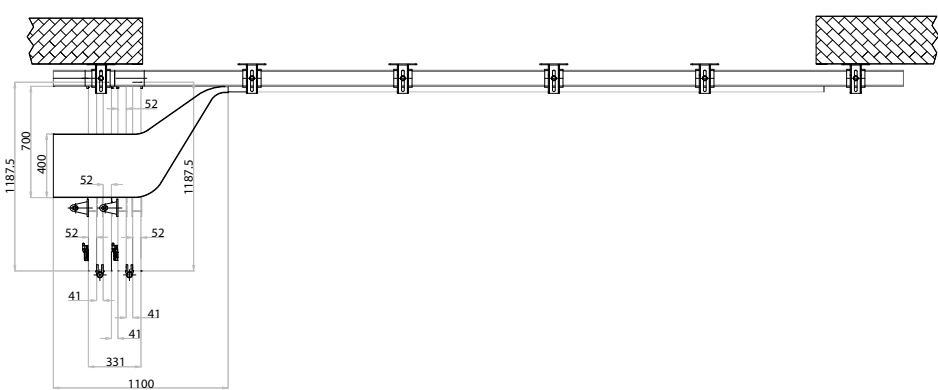

Particolari tecnici
Technical details

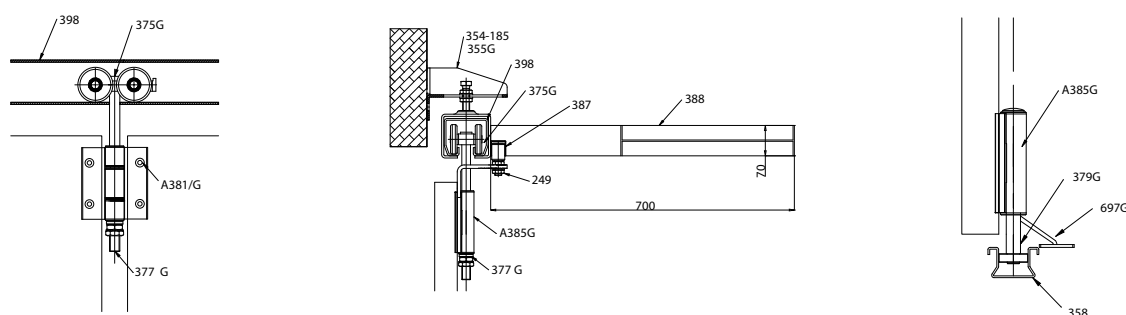

ART.	DESCRIPTION	Box info	PAG.
		Pcs per pack	
398	Monorotaia superiore per carrelli 4 ruote grande zincata Large galvanized upper guide for trolleys with four wheels / Rail supérieur pour chariots 4 galets grands zincés / Obere laufschiene für rollenapparate mit 4 rollen gross verzinkt / Monocarril superior grande galvanizado para carros con 4 ruedas / Верхний монорельс для тележек с 4 колесами большой оцинкованный	1 (6,0 m)	311
354-185	Staffa regolabile a parete mm. 185 Adjustable wall rod 185 mm. / Support réglable au mur mm. 185 / Regulierbarer wandbügel 185 mm / Placa regulable de pared 185 mm / Регулируемый настенный кронштейн мм 185	6	299
355 G	Supporto guida regolabile Adjustable guide support / Support guide réglable / Regulierbare führung / Soporte guía regulable / Опора регулируемой направляющей	6	300
375 G	Carrello grande a 4 ruote in acciaio per perno da mm. 20 Large steel trolley with four wheels for pin, 20 mm. / Chariot grand a 4 galets en acier pour pivot de mm. 20 / Rollenapparat gross mit 4 stahlrollen für bolzen 20 mm / Carro grande con 4 ruedas de acero para perno de 20 mm / Большая тележка 4 стальными колесами для штифта мм 20	3	307
694 MC	Cariglione star grande Large star lever bolt / Cremona star grande / Treibriegel star gross / Falleba star grande / Большой болтовой рычаг star	2 SX	321
699	Maniglione di trascinamento in nylon con passanti Nylon pull handle with guides / Poignée d'entraînement en nylon avec traversants / Nylongriff zum ziehen mit laschen / Tirador de nylon con puentes / Ручка из нейлона со сквозными направляющими	2	323
695 G	Asta di chiusura tubolare 30x10 Closing tubular rod 30x10 / Tringle tubulaire de fermeture 30x10 / Rohrverschlussstange 30x10 / Varilla de cierre tubular 30x10 / Закрывающий стержень трубчатый 30x10	2 (1,20 m) + 2 (3,0 m)	322
691 G	Passante per aste 30x10 Rod guide 30x10 / Traversant pour tringles 30x10 / Lasche für stangen 30x10 / Puente para varillas 30x10 / Сквозная направляющая для стержней 30x10	6	319
365	Incontro per aste Floor strike plate for rods / Butoir pour tringles / Auftaufschuh für stangen / Encuentro para varillas / Упор для стержней	2	303
A380 G	Cerniera doppia grande in alluminio con battute Large aluminium double hinge with steps / Paumelle double grande en aluminium avec butees / Doppelscharnier klein aus aluminium fisch, ohne bolzen / Pernio doble grande de aluminio con topes / Большой двойной шарнир из алюминия с упорами	7	326
A381 G	Cerniera doppia grande in alluminio con battute, senza perno Large aluminium double hinge with steps, without pin / Paumelle double grande en aluminium avec butees, sans pivot / Doppelscharnier aus aluminium fisch, regulierbar / Pernio doble grande de aluminio con topes, sin eje / Большой двойной шарнир из алюминия с упорами, без штифта	2	327
A385 P	Cerniera singola in alluminio con battuta Large aluminium hinge with step / Paumelle simple grande en aluminium avec batee / Einzel-scharnier klein aus aluminium mit stütze / Pernio de aluminio con tope / Одинарный шарнир из алюминия с упором	4	328
377 G 330	Perno superiore per carrelli Upper pin for trolleys / Pivot supérieur pour chariots / Oberer bolzen für rollenapparate / Perno superior para carros / Верхний штырь для тележек	3	307
379 G 200	Perno inferiore regolabile con cuscinetto Adjustable lower pin with bearing / Pivot inférieur réglable avec roulement / Regulierbarer unterer bolzen mit kugellager / Perno inferior regulable con rodamiento / Нижний регулируемый штифт с подшипником	3	305
358	Guida inferiore a cementare da mt. 6,00 Lower guide to be cemented, length 6 meters / Guide inférieure a cimenter de m. 6,00 / Untere führung zum einzementieren, länge 6 m / Guía inferior para cementar de 6,00 m / Нижняя цементируемая направляющая м 6,00	1 (6,0 m)	301
387	Profilo ad "u" per deviatori ad impacco laterale "U" profile for side folding switches / Profil en "u" pour deviateurs pour portail pliable lateral / U-profil für ablenker für seitliche paket-lagerung / Perfil en "U" para desviadores para puerta plegable lateral / Профиль в форме "u" для отклоняющего устройства с боковым воздействием	1 (6,0 m)	308
249-30	Deviatore regolabile per impacchettamento laterale Adjustable switcher for side folding / Deviateur réglable pour portail pliable lateral / Regulierbarer ablenker für seitliche paket-lagerung / Desviador regulable para puerta plegable lateral / Регулируемое отклоняющее устройство для боковой завертки	2	296
246	Battente fincorsa per monorotaie art. 398/399 End-supper for guides art. 398/399 / Batee de fin de course pour rails art. 398/399 / Letzter türflügel für laufschiene art. 398/399 / Tope para monocarril art. 398/399 / Стопор конца хода для монорельсов art. 398/399	1	295
239	Tappo ammortizzatore ante Door leaf suppper / Embout d'amortissage vantaux / Stossdämpfer für türe / Amortiguador hojas / Амортизирующая пробка створки	3	295



Portoni industriali

Industrial door systems

KIT

4 Ante impacchettamento laterale con carrello 4 ruote
 4 Side folding panels with 4 wheel trolley / 4 Vantaux ramassage latéral avec chariot à 4 galets / 4 Flügel seitliche paket-lagerung mit vierdrägen rollenapparat / 4 Hojas plegables con carro 4 ruedas / 4 Створки с боковой закруткой с тележкой 4 колеса

COMUNELLO
 GATE DIVISION

Schema con ante chiuse
 Diagram with closed doors

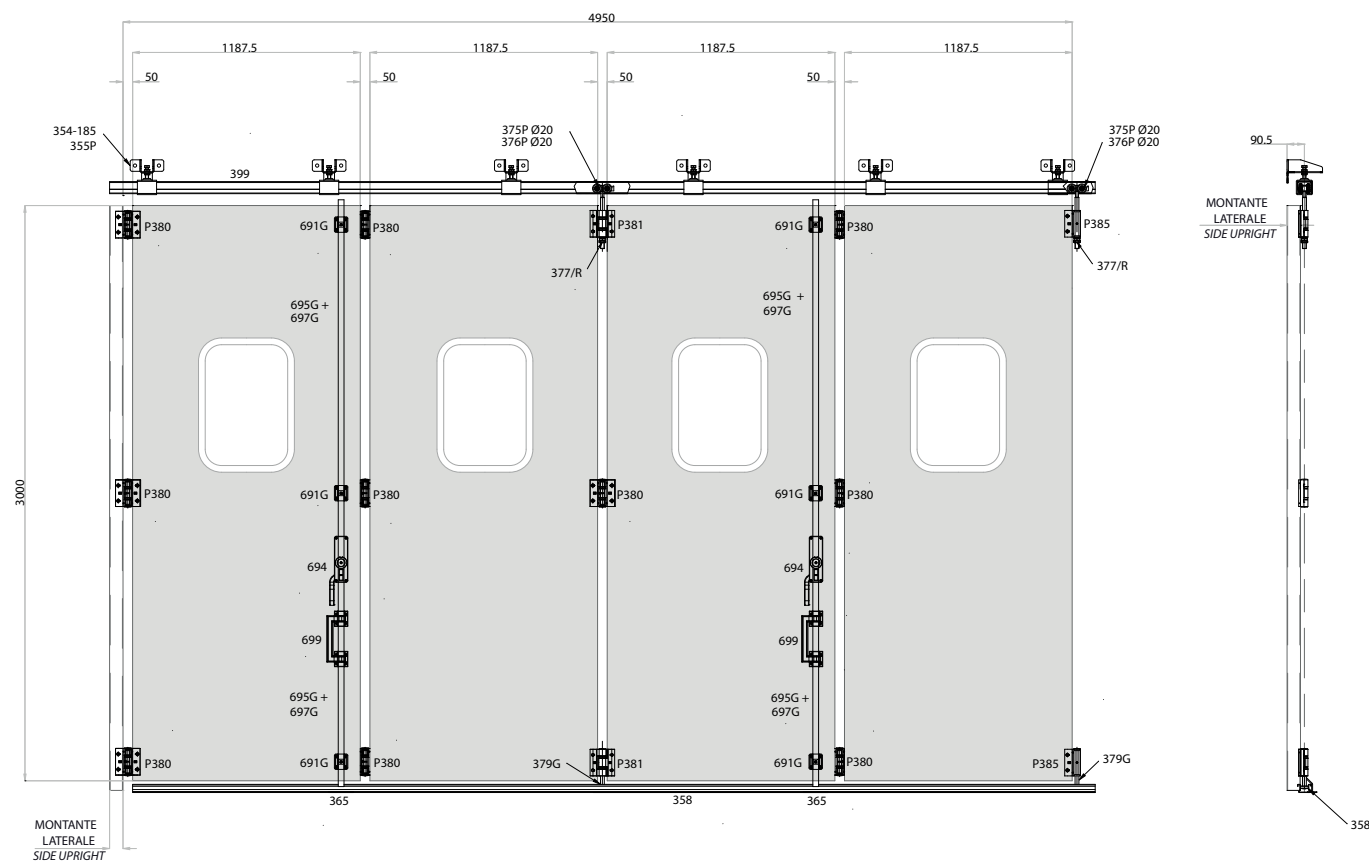

Schema con ante aperte/chiusa
 Diagram with open/closed doors

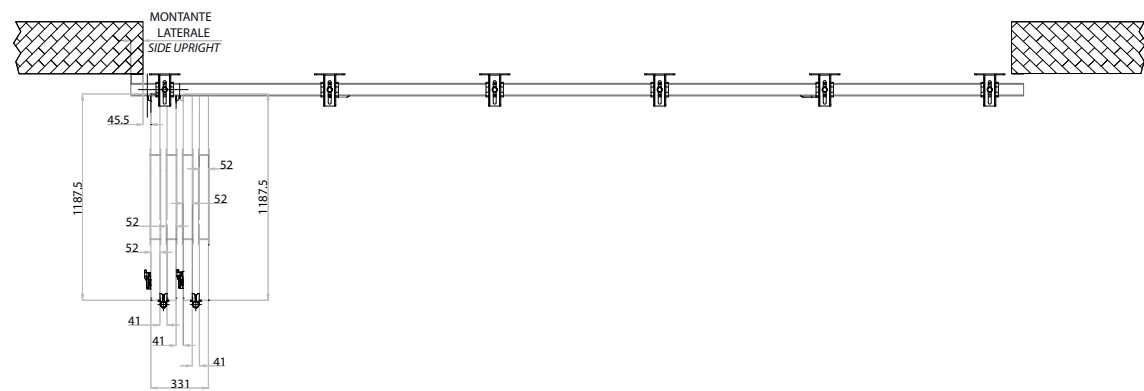

Particolari tecnici
 Technical details

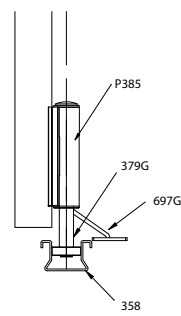
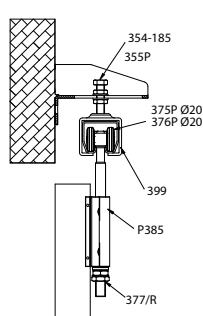
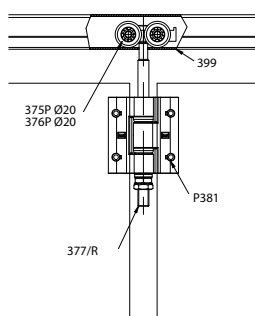

	ART.	DESCRIPTION	Box info Pcs per pack	PAG.
	399	Monorotaia superiore per carrelli 4 ruote piccola zincata Small galvanized upper guide for trolleys with four wheels / Rail supérieur pour chariots 4 galets petits zingues / Obere laufschiene für rollenapparate mit 4 rollen klein verzinkt / Monocami superior pequeño galvanizado para carros con 4 ruedas / Верхний монорельс для тележек с 4 колесами малый оцинкованный	1 (6,0 m)	311
	354-185	Staffa regolabile a parete mm. 185 Adjustable wall rod 185 mm. / Support réglable au mur mm. 185 / Regulierbarer wandbügel 185 mm / Placa regulable de pared 185 mm / Регулируемый настенный кронштейн мм 185	6	299
	355 P	Supporto guida regolabile Adjustable guide support / Support guide réglable / Regulierbare führung / Soporte guía regulable / Опора регулируемой направляющей	6	300
	375 P20 / 376 P20	Carrello piccolo a 4 ruote in acciaio / nylon Small steel trolley with four wheels - nylon / Chariot petit à 4 galets en acier - nylon / Rollenapparat klein mit 4 stahlrollen - nylonrollen / Carro pequeño con 4 ruedas de acero - nylon / Маленькая тележка с 4 нейлоновыми/стальными колесами	2	307
	694 MC	Cariglione star grande Large star lever bolt / Cremona star grande / Treibriegel star gross / Falleba star grande / Большой болтовой рычаг star	2 SX	321
	699	Maniglione di trascinamento in nylon con passanti Nylon pull handle with guides / Poignée d'entraînement en nylon avec traversants / Nylongriff zum ziehen mit laschen / Tirador de nylon con puentes / Ручка из нейлона со сквозными направляющими	2	323
	695 G	Asta di chiusura tubolare 30x10 Closing tubular rod 30x10 / Tringle tubulaire de fermeture 30x10 / Rohrverschlussstange 30x10 / Varilla de cierre tubular 30x10 / Закрывающий стержень трубчатый 30x10	2 (1,20 m) + 2 (3,0 m)	322
	691 G	Passante per aste 30x10 Rod guide 30x10 / Traversant pour tringles 30x10 / Lasche für stangen 30x10 / Puente para varillas 30x10 / Сквозная направляющая для стержней 30x10	6	319
	365	Incontro per aste Floor strike plate for rods / Butoir pour tringles / Auftaufschuh für stangen / Encuentro para varillas / Упор для стержней	2	303
	P380	Cerniera doppia in alluminio pressofuso con battute Die-cast aluminium double hinge with steps / Paumelle double en aluminium moulée avec butees / Doppelscharnier aus alu-druckguss flach, ohne bolzen / Pernio doble de aluminio fundido a presión con topes / Плоский двойной шарнир из литого алюминия с упорами	10	331
	P381	Cerniera doppia in alluminio pressofuso con battute, senza perno Die-cast aluminium double hinge, without pin / Paumelle double en aluminium moulée avec butees, sans pivot / Doppelscharnier aus alu-druckguss mit stützen / Pernio doble de aluminio fundido a presión con topes, sin eje / Двойной шарнир из литого алюминия с упорами без штифта	2	329
	P385	Cerniera singola in alluminio pressofuso con battuta Die-cast aluminium hinge with step / Paumelle simple en aluminium moulée avec batee / Einzel-scharnier aus alu-druckguss flach / Pernio de aluminio fundido a presión con tope / Одинарный шарнир из литого алюминия с упором	2	332
	377 R	Perno superiore ribassato Lowered upper pin / Pivot supérieur surbaisse / Oberer bolzen herabgesenkt / Perno superior rebajado / Верхний штырь пониженный	2	308
	379 G 200	Perno inferiore regolabile con cuscinetto Adjustable lower pin with bearing / Pivot inférieur réglable avec roulement / Regulierbarer unterer bolzen mit kugellager / Perno inferior regulable con rodamiento / Нижний регулируемый штифт с подшипником	2	305
	358	Guida inferiore a cementare da mt. 6,00 Lower guide to be cemented, length 6 meters / Guide inférieure a cimenter de m. 6,00 / Untere führung zum einzementieren, länge 6 m / Guía inferior para cementar de 6,00 m / Нижняя цементируемая направляющая м 6,00	1 (6,0 m)	301
	239	Tappo ammortizzatore ante Door leaf stopper / Embout d'amortissage vantaux / Stossdämpfer für türe / Amortiguador hojas / Амортизирующая пробка створки	3	295



Schema con ante chiuse
Diagram with closed doors

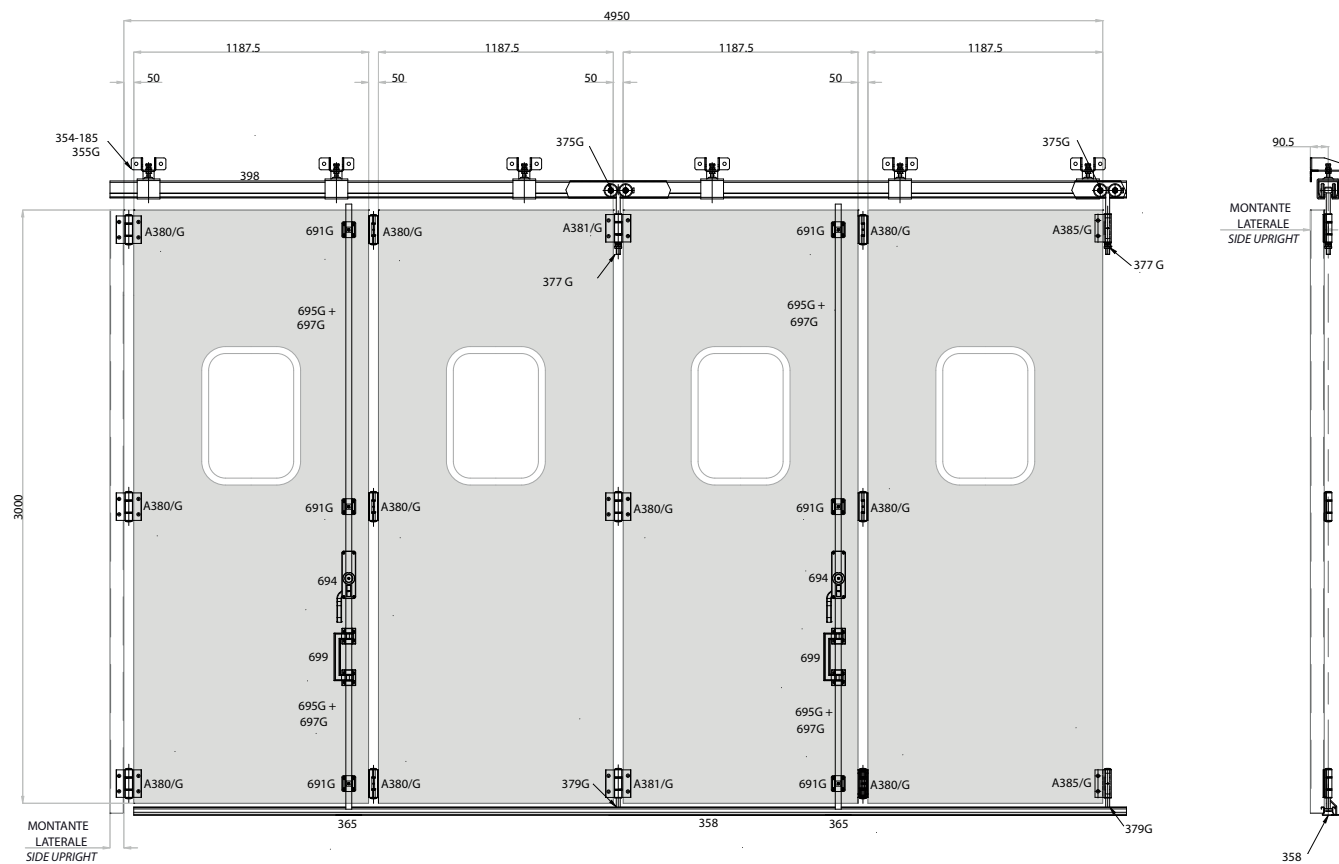

Schema con ante aperte/chiusa
Diagram with open/closed doors

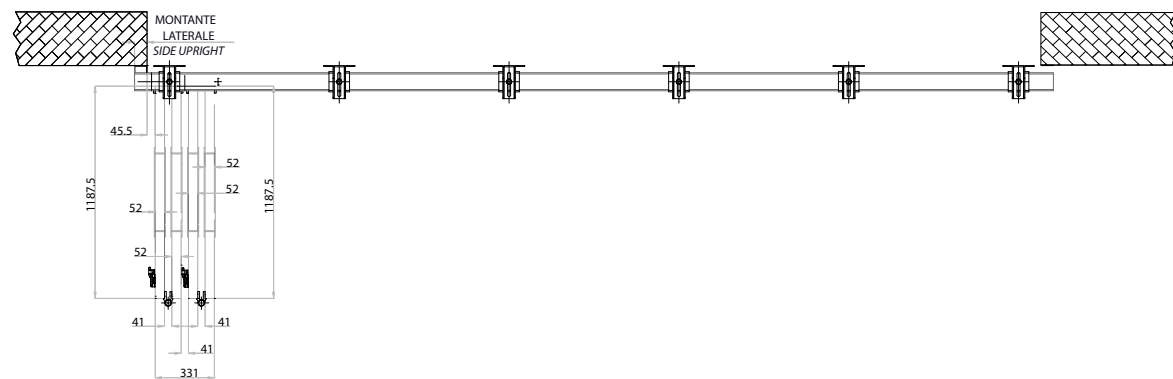

Particolari tecnici
Technical details

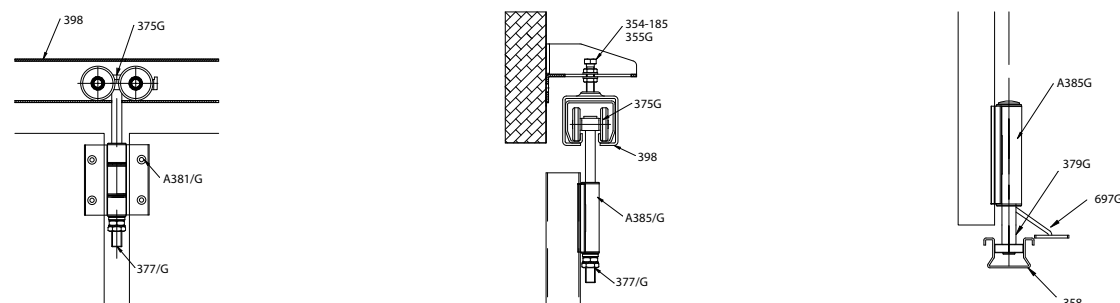

ART.	DESCRIPTION	Box info	PAG.
		Pcs per pack	
398	Monorotaia superiore per carrelli 4 ruote grande zincata Large galvanized upper guide for trolleys with four wheels / Rail supérieur pour chariots 4 galets grands zincés / Obere laufschiene für rollenapparate mit 4 rollen gross verzinkt / Monocamil superior grande galvanizado para carros con 4 ruedas / Верхний монороль для тележек с 4 колесами большой оцинкованный	1 (6.0 m)	311
354-185	Staffa regolabile a parete mm. 185 Adjustable wall rod 185 mm. / Support réglable au mur mm. 185 / Regulierbarer wandbügel 185 mm / Placa regulable de pared 185 mm / Регулируемый настенный кронштейн мм 185	6	299
355 G	Supporto guida regolabile Adjustable guide support / Support guide réglable / Regulierbare führung / Soporte guía regulable / Опора регулируемой направляющей	6	300
375 G	Carrello grande a 4 ruote in acciaio per perno da mm. 20 Large steel trolley with four wheels for pin, 20 mm. / Chariot grand a 4 galets en acier pour pivot de mm. 20 / Rollenapparat gross mit 4 stahlrollen für bolzen 20 mm / Carro grande con 4 ruedas de acero para perno de 20 mm / Большая тележка 4 стальными колесами для штифта мм 20	2	307
694 MC	Cariglione star grande Large star lever bolt / Cremona star grande / Treibriegel star gross / Falleba star grande / Большой болтовой рычаг star	2 SX	321
699	Maniglione di trascinamento in nylon con passanti Nylon pull handle with guides / Poignée d'entraînement en nylon avec traversants / Nylongriff zum ziehen mit laschen / Tirador de nylon con puentes / Ручка из нейлона со сквозными направляющими	2	323
695 G	Asta di chiusura tubolare 30x10 Closing tubular rod 30x10 / Tringle tubulaire de fermeture 30x10 / Rohrverschlussstange 30x10 / Varilla de cierre tubular 30x10 / Закрывающий стержень трубчатый 30x10	2 (1.20 m) + 2 (3.0 m)	322
691 G	Passante per aste 30x10 Rod guide 30x10 / Traversant pour tringles 30x10 / Lasche für stangen 30x10 / Puente para varillas 30x10 / Сквозная направляющая для стержней 30x10	6	319
365	Incontro per aste Floor strike plate for rods / Butoir pour tringles / Auftaufschuh für stangen / Encuentro para varillas / Упор для стержней	2	303
A380 G	Cerniera doppia grande in alluminio con battute Large aluminium double hinge with steps / Paumelle double grande en aluminium avec butees / Doppelscharnier klein aus aluminium fisch, ohne bolzen / Pernio doble grande de aluminio con topes / Большой двойной шарнир из алюминия с упорами	10	326
A381 G	Cerniera doppia grande in alluminio con battute, senza perno Large aluminium double hinge with steps, without pin / Paumelle double grande en aluminium avec butees, sans pivot / Doppelscharnier aus aluminium fisch, regulierbar / Pernio doble grande de aluminio con topes, sin eje / Большой двойной шарнир из алюминия с упорами, без штифта	2	327
377 G 330	Perno superiore per carrelli Upper pin for trolleys / Pivot supérieur pour chariots / Oberer bolzen für rollenapparate / Perno superior para carros / Верхний штырь для тележек	2	307
379 G 200	Perno inferiore regolabile con cuscinetto Adjustable lower pin with bearing / Pivot inférieur réglable avec roulement / Regulierbarer unterer bolzen mit kugellager / Perno inferior regulable con rodamiento / Нижний регулируемый штифт с подшипником	2	305
358	Guida inferiore a cementare da mt. 6,00 Lower guide to be cemented, length 6 meters / Guide inferieure a cimenter de m. 6,00 / Untere führung zum einzementieren, länge 6 m / Guía inferior para cementar de 6,00 m / Нижняя цементируемая направляющая м 6,00	1	301
239	Tappo ammortizzatore ante Door leaf suppperper / Embout d'amortissage vantaux / Stossdämpfer für türe / Amortiguador hojas / Амортизирующая пробка створки	3	295



CODE	ART.	CAT.	PAG.
10100505 001	2	1C	282
10100610 001	2C	1C	282
10100615 001	2C	1C	282
10101005 001	4	1C	282
10101110 001	4C	1C	283
10101115 001	4C	1C	283
10102005 001	8	1C	284
10102110 001	8C	1C	284
10102115 001	8C	1C	284
10102505 001	10	1C	284
10102610 001	10C	1C	285
10102615 001	10C	1C	285
10103110 001	14C	1C	285
10103115 001	14C	1C	285
10103610 001	16C	1C	285
10103615 001	16C	1C	285
10104610 001	20C	1C	286
10104615 001	20C	1C	286
10605005 001	22	1L	287
10605000 001	22	1L	287
10605010 001	22	1L	287
10605505 001	23	1I	288
10605500 001	23	1I	288
10605510 001	23	1I	288
10200505 001	24	1I	286
10200510 001	24	1I	286
10200515 001	24	1I	286
10300505 001	26	1L	286
10300510 001	26	1L	286
10301005 001	28	1L	286
10301010 001	28	1L	286
10301505 001	30-25	1L	289
10400505 001	32-34	1L	289
10500505 001	34-M12	1L	290
10500510 001	34-M20	1L	290
10302005 001	36-25	1L	290
10302010 001	36-30	1L	290
10105505 001	38-24	1C	290
10106005 001	39-24	1C	291
10106505 001	40-24	1C	291
10107005 001	41-24	1C	291
10501005 001	42 P	1L	292
10501010 001	42 G	1L	292
10107505 001	43-24	1C	292
10108005 001	44-24	1C	292
10108505 001	46-24	1C	293
10109005 001	48-24	1C	293
10109505 001	50-24	1C	293
10110005 001	52-24	1C	294
10110505 001	54-24	1C	294
10111005 001	56-24	1C	294
10111505 001	60-24	1C	295

CODE	ART.	CAT.	PAG.
11210020	73-10	1N	176
11210025	73-20	1N	176
11210030	73-30	1N	176
11210005	73-40	1N	176
11210010	73-50	1N	176
11210015	73-60	1N	176
11210020 503	73-10	1N	176
11210025 503	73-20	1N	176
11210030 503	73-30	1N	176
11210005 503	73-40	1N	176
11210010 503	73-50	1N	176
11210015 503	73-60	1N	176
11210520	74-10	1N	177
11210525	74-20	1N	177
11210530	74-30	1N	177
11210505	74-40	1N	177
11210510	74-50	1N	177
11210515	74-60	1N	177
11210520 503	74-10	1N	177
11210525 503	74-20	1N	177
11210530 503	74-30	1N	177
11210505 503	74-40	1N	177
11210510 503	74-50	1N	177
11210515 503	74-60	1N	177
11213505	78	1N	178
11213505 502	78	1N	178
11215005	80	1N	178
10822505 001	81-M22	1A	20
10822510 001	81-M24	1A	20
10823005 001	82-M22	1A	21
10823010 001	82-M24	1A	21
10800305	84I	2A	29
10800407 001	85M	1A	22
10800410 001	85G	1A	22
10801607 001	85L-M	1A	24
10801610 001	85L-G	1A	24
10801407 001	85PST-M	1A	24
10801410 001	85PST-G	1A	24
10800411 001	85XL	1A	23
10800505 001	86P	1A	24
10800605	86I-P	2A	25
10800510 001	86G	1A	25
10800610	86I-G	2A	25
10801805 001	86L-P	1A	26
10801810 001	86L-G	1A	26
10801710 001	86PST	1A	26
10801005 001	87P	1A	27
10801105	87I-P	2A	27
10801110	87I-G	2A	27
10801007 001	87M	1A	28
10801010 001	87G	1A	28
10801305 001	87L-P	1A	29

CODE	ART.	CAT.	PAG.
10801307 001	87L-M	1A	30
10801310 001	87L-G	1A	30
10801205 001	87PST-P	1A	29
10801207 001	87PST-M	1A	31
10801210 001	87PST-G	1A	31
10801011 001	87XL	1A	32
10801505 001	88-40	1A	33
10801510 001	88-50	1A	33
10801515 001	88-60	1A	33
10802105 001	88L-40	1A	34
10802110 001	88L-50	1A	34
10802115 001	88L-60	1A	34
10802205 001	88PST-40	1A	34
10802210 001	88PST-50	1A	34
10802215 001	88PST-60	1A	34
10802005	89-40	1A	34
10802010	89-50	1A	34
10802015	89-60	1A	34
10802505	90P	1A	35
10802510	90G	1A	35
10803005	92G	1A	36
10803505 001	94P	1A	36
10803510 001	94G	1A	36
10804005 001	96G	1A	36
10804505	100P	1A	38
10804510	100G	1A	38
10804605 001	100PST-P	1A	37
10804610 001	100PST-G	1A	37
10805005	105-20	1A	39
10805105 001	105PST	1A	37
10805205 001	106-20	1A	37
10805210 001	106-27	1A	37
10805305 001	106PST-20	1A	40
10805310 001	106PST-27	1A	40
10805505	110-20	1A	41
10805510	110-24	1A	41
10805515	110-27	1A	41
10806005	115-20,5	1A	41
10806010	115-24,5	1A	41
10806015	115-28	1A	41
10806405 001	115PST-20,5	1A	42
10806410 001	115PST-24,5	1A	42
10806415 001	115PST-28	1A	42
10806205	116I-20	2A	42
10806210	116I-24	2A	42
10807305 001	117-20,5	1A	42
10807310 001	117-24,5	1A	42
10807315 001	117-28	1A	42
10807405 001	117PST-20,5	1A	43
10807410 001	117PST-24,5	1A	43
10807415 001	117PST-28	1A	43
10806500 001	120-M18	1A	44

CODE	ART.	CAT.	PAG.
10806505 001	120-M20	1A	44
10806509 001	120-M22	1A	44
10806510 001	120-M24	1A	44
10806505 020	120-M20 Hs700	1A	44
10806510 020	120-M24 Hs700	1A	44
10806605	120I-M20	2A	43
10806610	120I-M24	2A	43
10807005 001	125-M20	1A	43
10807010 001	125-M24	1A	43
10807505 001	130-M20	1A	46
10807510 001	130-M24	1A	46
10808005 001	135-M18	1A	45
10808009 001	135-M20	1A	45
10808010 001	135-M22	1A	45
10808014 001	135-M24	1A	45
10808015 001	135-M27	1A	45
10808505 001	140-M18	1A	46
10808510 001	140-M22	1A	46
10808515 001	140-M27	1A	46
10809005 001	150-M18	1A	46
10809010 001	150-M22	1A	46
10824705 001	154-M18	1A	47
10824710 001	154-M20	1A	47
10824715 001	154-M22	1A	47
10824720 001	154-M24	1A	47
10824725 001	154-M27	1A	47
10824405 001	154R-CV-M18	1A	48
10824410 001	154R-CV-M20	1A	48
10824415 001	154R-CV-M22	1A	48
10824420 001	154R-CV-M24	1A	48
10809505 001	155-M20	1A	49
10809510 001	155-M24	1A	49
10824605 001	157CV-M18	1A	47
10824610 001	157CV-M20	1A	47
10824615 001	157CV-M22	1A	47
10824620 001	157CV-M24	1A	47
10824905 001	157-AL-M18	1A	47
10824910 001	157-AL-M20	1A	47
10824915 001	157-AL-M22	1A	47
10824920 001	157-AL-M24	1A	47
10823505 001	159-M18	1A	50
10823510 001	159-M20	1A	50
10823515 001	159-M22	1A	50
10823520 001	159-M24	1A	50
10823525 001	159-M27	1A	50
10823405 001	159R-CV-M18	1A	50
10823410 001	159R-CV-M20	1A	50
10823415 001	159R-CV-M22	1A	50
10823420 001	159R-CV-M24	1A	50
10810005 001	160-M18	1A	51
10810010 001	160-M22	1A	51
10810015 001	160-M27	1A	51

CODE	ART.	CAT.	PAG.
10801912 001	160XL	1A	50
10810300 001	161-M18	1A	52
10810305 001	161-M20	1A	52
10810309 001	161-M22	1A	52
10810310 001	161-M24	1A	52
10810505 001	162-M20	1A	52
10810510 001	162-M24	1A	52
10810805 001	163-M18	1A	52
10810809 001	163-M20	1A	52
10810810 001	163-M22	1A	52
10810814 001	163-M24	1A	52
10810815 001	163-M27	1A	52
10811005 001	164-M18	1A	53
10811010 001	164-M22	1A	53
10811015 001	164-M27	1A	53
12100505	165-30	1G	72
12100510	165-40	1G	72
12100515	165-50	1G	72
12100520	165-60	1G	72
12100525	165-80	1G	72
12100530	165-100	1G	72
12100535	165-120	1G	72
12100540	165-150	1G	72
12100550	165-200	1G	72
12100505 001	165Z-30	1G	72
12100510 001	165Z-40	1G	72
12100515 001	165Z-50	1G	72
12100520 001	165Z-60	1G	72
12100525 001	165Z-80	1G	72
12100530 001	165Z-100	1G	72
12100535 001	165Z-120	1G	72
12100540 001	165Z-150	1G	72
12100550 001	165Z-200	1G	72
12100805	165T-30	1G	73
12100810	165T-33	1G	73
12100815	165T-42	1G	73
12100820	165T-48	1G	73
12100830	165T-76	1G	73
12100835	165T-89	1G	73
12100845	165T-114	1G	73
12100705	165I-30	2G	73
12100710	165I-40	2G	73
12100715	165I-50	2G	73
12100720	165I-60	2G	73
12100725	165I-80	2G	73
12100730	165I-100	2G	73
12100735	165I-120	2G	73
12100740	165I-150	2G	73
10704601 001	166P	1G	66
10704602 001	166G	1G	66
10700705 00			



CODE	ART.	CAT.	PAG.
10819005	198-30	1A	62
10819010	198-35	1A	62
10819015	198-40	1A	62
10704701	199-40	1G	76
10704705	199-50	1G	76
10704710	199-60	1G	76
10701505 001	200P	1G	76
10701510 001	200G	1G	76
10701610	200i-G	2G	76
10701450 001	201	1G	78
10701810 001	202	1G	77
10704301 001	202F-B	1G	79
10704201 001	202F-A	1G	77
10704401 001	202F-C	1G	77
10502101	202A	1G	81
10704501 001	203	1G	81
10704550 001	204	1G	80
10900505	205	1H	178
10906601 604	209	1H	179
10906601 503	209	1H	179
10901005 503	210-25-35	1H	179
10901005 516	210-25-35	1H	179
10901010 503	210-40-50	1H	179
10901010 516	210-40-50	1H	179
10901015 503	210-50-60	1H	179
10901015 516	210-50-60	1H	179
10901020 503	210-60-70	1H	179
10901020 516	210-60-70	1H	179
10901305 516	211	1H	179
10901305 503	211	1H	179
10905501 503	213	1H	180
11200501 001	215-50	1N	180
11200505 001	215-60	1N	180
11200601 001	215S-50	1N	180
11200605 001	215S-60	1N	180
11201005 001	216	1N	181
11201701	217-40	1N	181
11201705	217-50	1G	181
11201710	217-60	1G	181
11202005	220-40	1G	181
11202010	220-50	1G	181
11215530 001	222-30	1N	182
11215535 001	222-35	1N	182
11215540 001	222-40	1N	182
11215545 001	222-45	1N	182
11215550 001	222-50	1N	182
11215560 001	222-60	1N	182
11215531 001	223-30	1N	182
11215536 001	223-35	1N	182
11215541 001	223-40	1N	182
11215546 001	223-45	1N	182
11215551 001	223-50	1N	182

CODE	ART.	CAT.	PAG.
11215561 001	223-60	1N	182
11300505 001	227-30	1L	84
11300510 001	227-42	1L	84
11301005 001	230-25	1L	84
11301010 001	230-30	1L	84
11301015 001	230-40	1L	84
11301017 001	230-41	1L	84
11301020 001	230-42	1L	84
11301310	230i-30	2L	84
11301315	230i-40	2L	84
11301505 001	231-52	1L	85
11302210 001	232-30	1L	85
11302215 001	232-40	1L	85
11302005 001	235-35	1L	85
10700405	239	3E	295
11302010 001	240-37,5	1L	86
11302505 001	242-37,5	1L	86
11303005 001	243-25	1L	86
11303010 001	243-30	1L	86
11303015 001	243-40	1L	86
11303505 001	244-25	1L	87
11303510 001	244-30	1L	87
11303515 001	244-40	1L	87
11304005 001	245-32	1L	87
11304010 001	245-35	1L	87
11304015 001	245-42	1L	87
10701705 001	246	3G	295
11305005 001	247	1L	87
11307500 001	248-60	3H	296
11307501 001	248-70	3H	296
11307505 001	248-80	3H	296
10401505 001	249-30	3E	296
11305505 001	250-220	1L	88
11305605	250i-220	2L	88
11305805 001	251-220	1L	89
11305810 001	251-300	1L	89
11306205 001	252-200	1L	90
11305701 001	253-40	1L	90
11306005 001	255-220	1L	91
11306010 001	255-350	1L	91
11306105	255i-220	2L	91
11305905 001	256-220	1L	92
11305910 001	256-300	1L	92
11306510 001	257-300	1L	91
11306515 001	257-400	1L	91
11306520 001	257-500	1L	91
11306525 001	257-600	1L	91
11306530 001	257-700	1L	91
11306535 001	257-800	1L	91
11306405 001	258-30	1L	93
11400505 001	260-22x22	1F	96
11400510 001	260-22x22	1F	96

CODE	ART.	CAT.	PAG.
11400515 001	260-30x30	1F	96
11400610	260i-22x22	2F	96
11400101	261-26x20	1F	96
11401205 001	262-30x8	1F	97
11401005 001	262-30x12	1F	97
11401010 001	262-30x12	1F	97
11401105	262i-30x12	2F	97
11401710 001	263	1F	97
11401505 001	264	1F	98
11401905	264i	2F	98
11402001	265	1F	99
11402005	265	1F	99
11402505 001	266	1F	99
10902005 001	270P	1H	296
10902010 001	270G	1H	296
10902505	270i-P	2H	297
10902510	270i-G	2H	297
10903005 001	272	1H	297
10702005 001	275	1G	204
10702010 001	275F-30	1G	204
10702015 001	275F-40	1G	204
10702020 001	275F-50	1G	204
10702025 001	275F-60	1G	204
10701301 001	275PST	1G	205
10701401 001	276	1G	205
10812005 001	282-30x30	1A	63
10813005 001	285-30x30	1A	63
10204001 001	287P-015-Sp3	1I	102
10204011 001	287P-015-Sp3	1I	102
10204002 001	287P-015-Sp3	1I	102
10204012 001	287P-015-Sp3	1I	102
10204018 001	287-017-Sp3	1I	102
10204020 001	287-017-Sp3	1I	102
10204013 001	287G-019-Sp3	1I	102
10204007 001	287G-019-Sp3	1I	102
10204014 001	287G-019-Sp3	1I	102
10204008 001	287G-019-Sp3	1I	102
10204015 001	287G-019-Sp4	1I	102
10204009 001	287G-019-Sp4	1I	102
10204016 001	287G-019-Sp4	1I	102
10204010 001	287G-019-Sp4	1I	102
10204201 001	287FP-G	1I	103
10204202 001	287FP-G	1I	103
10204113	287i-Go19-SP2	2I	104
10204114	287i-Go19-SP2	2I	104
10201501 001	289P-015-Sp3	1I	104
10201502 001	289P-015-Sp3	1I	104
10201505 001	289G-019-Sp3	1I	104
10201510 001	289G-019-Sp3	1I	104
10201605	289i-Go19-SP2	2I	104
10201610	289i-Go19-SP2	2I	104
10601501 001	290	1I	105

CODE	ART.	CAT.	PAG.
10602005 001	291	1I	105
10602105	291i	2I	105
10201905 001	292	1I	106
10201910 001	292	1I	106
10201705 001	293	1I	106
10201710 001	293	1I	106
10201805	293i	2I	106
10201810	293i	2I	106
10602205 001	294	1I	107
10602405 001	295	1I	107
10602305	295i	2I	107
10601605 001	297	1I	108
10601610 001	297G	1I	108
10601705	297i	2I	108
11501001 001	300V-40	1M	112
11501005 001	300V-50	1M	112
11501010 001	300V-60	1M	112
11501015 001	300V-70	1M	112
11501020 001	300V-80	1M	112
11501030 001	300V-90	1M	112
11501040 001	300V-100	1M	112
11501050 001	300V-120	1M	112
11501060 001	300V-140	1M	112
11501070 001	300V-160	1M	112
11501080 001	300V-200	1M	112
11501410	300i-V60	2M	112
11501420	300i-V80	2M	112
11501430	300i-V90	2M	112
11501440	300i-V100	2M	112
11501450	300i-V120	2M	112
11501460	300i-V140	2M	112
11501470	300i-V160	2M	112
11501480	300i-V200	2M	112
11500501 001	300U-40	1M	113
11500505 001	300U-50	1M	113
11500510 001	300U-60	1M	113
11500515 001	300U-70	1M	113
11500520 001	300U-80	1M	113
11500530 001	300U-90	1M	113
11500540 001	300U-100	1M	113
11500550 001	300U-120	1M	113
11500560 001	300U-140	1M	113
11500570 001	300U-160	1M	113
11500580 001	300U-200	1M	113
11502140	305i-V100	2M	113
11502150	305i-V120	2M	113
11502160	305i-V140	2M	113
11502170	305i-V160	2M	113
11502180	305i-V200	2M	113
11502040 001	305V-100	1M	114
11502050 001	305V-120	1M	114
11502060 001	305V-140	1M	114

CODE	ART.	CAT.	PAG.
11502070 001	305V-160	1M	114
11502080 001	305V-200	1M	114
11501540 001	305U-100	1M	115
11501550 001	305U-120	1M	115
11501560 001	305U-140	1M	115
11501570 001	305U-160	1M	115
11501580 001	305U-200	1M	115
11502510 001	306Y-60	1M	115
11502520 001	306Y-80	1M	115
11502530 001	306Y-90	1M	115
11502540 001	306Y-100	1M	115
11502550 001	306Y-120	1M	115
11502560 001	306Y-140	1M	115
11502570 001	306Y-160	1M	115
11502580 001	306Y-200	1M	115
11503040 001	307Y-100	1M	116
11503050 001	307Y-120	1M	116
11503060 001	307Y-140	1M	116
11503070 001	307Y-160	1M	116
11503080 001	307Y-200	1M	116
11503505 001	308-50	1M	116
11503510 001	308-60	1M	116
11503520 001	308-80	1M	116
11504020 001	309-80	1M	118
11504040 001	309-100	1M	118
11504050 001	309-120	1M	118
11504060 001	309-140	1M	118
11504501 001	310-40	1M	117
11504505 001	310-50	1M	117
11504510 001	310-60	1M	117
11504515 001	310-70	1M	117
11504520 001	310-80	1M	117
11504525 001	310-80S	1M	117
11504530 001	310-90	1M	117
11504535 001	310-90S	1M	117
11504540 001	310-100	1M	117
11504545 001	310-100S	1M	117
11504550 001	310-120	1M	117
11504560 001	310-140	1M	117
11504570 001	310-160	1M	



CODE	ART.	CAT.	PAG.
11507290 001	322Y-250	1M	122
11507540 001	323-100	1M	123
11507550 001	323-120	1M	123
11507570 001	323-160	1M	123
11507580 001	323-200	1M	123
11507590 001	323-250	1M	123
11508040 001	324-100	1M	123
11508041 001	324-100	1M	123
11508050 001	324-120	1M	123
11508051 001	324-120	1M	123
11508070 001	324-160	1M	123
11508071 001	324-160	1M	123
11508072 001	324-160	1M	123
11508080 001	324-200	1M	123
11508081 001	324-200	1M	123
11508082 001	324-200	1M	123
11508090 001	324-250	1M	123
11509010 001	325V-60	1M	124
11509020 001	325V-80	1M	124
11909030 001	325V-90	1M	124
11909040 001	325V-100	1M	124
11508510 001	325U-60	1M	125
11508520 001	325U-80	1M	125
11509240 001	326V-100	1M	125
11508740 001	326U-100	1M	125
11509510 001	327-60	1M	126
11509520 001	327-80	1M	126
11509525 001	327-80S	1M	126
11509740 001	328-100	1M	126
11510510 001	330V-60	1M	127
11510515 001	330V-70	1M	127
11510520 001	330V-80	1M	127
11510530 001	330V-90	1M	127
11510540 001	330V-100	1M	127
11510550 001	330V-120	1M	127
11510560 001	330V-140	1M	127
11510010 001	330U-60	1M	128
11510015 001	330U-70	1M	128
11510020 001	330U-80	1M	128
11510030 001	330U-90	1M	128
11510040 001	330U-100	1M	128
11510050 001	330U-120	1M	128
11510060 001	330U-140	1M	128
11510710 001	330Y-60	1M	128
11510715 001	330Y-70	1M	128
11510720 001	330Y-80	1M	128
11510730 001	330Y-90	1M	128
11510740 001	330Y-100	1M	128
11510750 001	330Y-120	1M	128
11510760 001	330Y-140	1M	128
11511010 001	332-60	1M	129
11511015 001	332-70	1M	129

CODE	ART.	CAT.	PAG.
11511020 001	332-80	1M	129
11511025 001	332-80S	1M	129
11511030 001	332-90	1M	129
11511035 001	332-90S	1M	129
11511040 001	332-100	1M	129
11511045 001	332-100S	1M	129
11511050 001	332-120	1M	129
11511060 001	332-140	1M	129
11512040 001	333V-100	1M	129
11512050 001	333V-120	1M	129
11512060 001	333V-140	1M	129
11511540 001	333U-100	1M	130
11511550 001	333U-120	1M	130
11511560 001	333U-140	1M	130
11512240 001	333Y-100	1M	130
11512250 001	333Y-120	1M	130
11512260 001	333Y-140	1M	130
11512540 001	334-100	1M	130
11512550 001	334-120	1M	130
11512560 001	334-140	1M	130
11513520 001	335V-80	1M	131
11513530 001	335V-90	1M	131
11513540 001	335V-100	1M	131
11513550 001	335V-120	1M	131
11513560 001	335V-140	1M	131
11513630	335i-V90	2M	132
11513640	335i-V100	2M	132
11513650	335i-V120	2M	132
11513020 001	335U-80	1M	132
11513030 001	335U-90	1M	132
11513040 001	335U-100	1M	132
11513050 001	335U-120	1M	132
11513060 001	335U-140	1M	132
11513720 001	335Y-80	1M	133
11513730 001	335Y-90	1M	133
11513740 001	335Y-100	1M	133
11513750 001	335Y-120	1M	133
11513760 001	335Y-140	1M	133
11514530 001	336V-90	1M	133
11514540 001	336V-100	1M	133
11514550 001	336V-120	1M	133
11514560 001	336V-140	1M	133
11514570 001	336V-160	1M	133
11514580 001	336V-200	1M	133
11514630	336i-90V	2M	134
11514640	336i-100V	2M	134
11514650	336i-120V	2M	134
11514030 001	336U-90	1M	134
11514040 001	336U-100	1M	134
11514050 001	336U-120	1M	134
11514060 001	336U-140	1M	134
11514070 001	336U-160	1M	134

CODE	ART.	CAT.	PAG.
11514080 001	336U-200	1M	134
11514730 001	336Y-90	1M	135
11514740 001	336Y-100	1M	135
11514750 001	336Y-120	1M	135
11514760 001	336Y-140	1M	135
11514770 001	336Y-160	1M	135
11514780 001	336Y-200	1M	135
11515020 001	337-80	1M	135
11515025 001	337-80S	1M	135
11515030 001	337-90	1M	135
11515035 001	337-90S	1M	135
11515040 001	337-100	1M	135
11515045 001	337-100S	1M	135
11515050 001	337-120	1M	135
11515060 001	337-140	1M	135
11515130	337i-90S	2M	136
11515140	337i-100S	2M	136
11515150	337i-120	2M	136
11515530 001	338-90	1M	136
11515540 001	338-100	1M	136
11515550 001	338-120	1M	136
11515560 001	338-140	1M	136
11515570 001	338-160	1M	136
11515580 001	338-200	1M	136
11515630	338i-90	2M	137
11515640	338i-100	2M	137
11515650	338i-120	2M	137
11515611 001	339U-120	1M	137
11515612 001	339U-160	1M	137
11515621 001	339V-120	1M	138
11515622 001	339V-160	1M	138
11515641 001	339-120	1M	139
11515642 001	339-140	1M	139
19907301 001	339-250	1M	139
11516010 001	340-60	1M	139
11516020 001	340-80	1M	139
11516040 001	340-100	1M	139
11516050 001	340-120	1M	139
11517020	342-80	1M	139
11517030	342-90	1M	139
11517040	342-100	1M	139
10602505 001	352P	3G	298
10602510 001	352G	3G	298
10603011 001	354-330	3G	299
10603006 001	354-185	3G	299
10603007 001	355P	3G	300
10603012 001	355G	3G	300
10603013 001	355S	3G	301
10604005 001	356P	3G	301
10604010 001	356G	3G	301
10202010 001	358	3G	301
10702505	361P	3E	302

CODE	ART.	CAT.	PAG.
10702510	361G	3E	302
10702611	362	3E	302
10702405	363	1G	302
10702405	364	3E	303
10702905 001	365	3E	303
10702105	365 AL	3E	303
10702210	366-22	3E	304
10702220	366-42	3E	304
10702305	367	3E	303
10113007 001	375 P16	3B	306
10113006 001	375 P20	3B	306
10113010 001	375 G	3B	307
10113402 001	376 P16	3B	307
10113401 001	376 P20	3B	307
10118550 001	377P	3E	307
10118535 001	377G-290	3E	307
10118535 002	377G-290	3E	307
10118535 003	377G-290	3E	307
10118540 001	377G-330	3E	307
10118540 002	377G-330	3E	307
10118540 003	377G-330	3E	307
10118530 001	377R-330	3E	308
10118530 002	377R-330	3E	308
10118530 003	377R-330	3E	308
10118701 001	377G-SC	3E	308
10310505 001	378P	3E	305
10310510 001	378G	3E	305
10311005 001	379P	3E	305
10311008 001	379G-135	3E	305
10311008 002	379G-135	3E	305
10311008 003	379G-135	3E	305
10311010 001	379G-200	3E	305
10311010 002	379G-200	3E	305
10311010 003	379G-200	3E	305
10210101 503	387	3G	308
10118350 503	395DX	3B	309
10118360 503	395SX	3B	309
10118305 503	396	3B	310
10203011 001	398	3G	311
10203012 001	398	3G	311
10203006 001	399	3G	311
10203008 001	399	3G	311
10203007 001	399	3G	311
12400503 001	400-9	1E	142
12400504 001	400-10	1E	142
12400505 001	400-11	1E	142
12400510 001	400-12	1E	142
12400515 001	400-14	1E	142
12400520 001	400-16,5	1E	142
12400525 001	400-20	1E	142
15400712 001	401S-12	1E	142
15400714 001	401S-14	1E	142

CODE	ART.	CAT.	PAG.
15400720 001	401S-20	1E	142
15400506 001	401Z-6	1E	143
15400508 001	401Z-8	1E	143
15400509 001	401Z-9	1E	143
15400510 001	401Z-10	1E	143
15400511 001	401Z-11	1E	143
15400512 001	401Z-12	1E	143
15400514 001	401Z-14	1E	143
15400606	401i-6	2E	143
15400608	401i-8	2E	143
15400609	401i-9	2E	143
15400610	401i-10	2E	143
15400611	401i-11	2E	143
15400612	401i-12	2E	143
15400614	401i-14	2E	143
11604006	402-60	1E	144
11604008	402-80	1E	144
11604010	402-100	1E	144
11604012	402-120	1E	144
11604014	402-140	1E	144
11604006 001	402Z-60	1E	144
11604008 001	402Z-80	1E	144
11604010 001	402Z-100	1E	144
11604012 001	402Z-120	1E	144
11604014 001	402Z-140	1E	144
11604206	402i-60	2E	144
11604208	402i-80	2E	144
11604210	402i-100	2E	144
11604212	402i-120	2E	144
11604214	402i-140	2E	144
11604514	405-140	1E	145
11604517	405-170	1E	145
11604520 001	405Z-200	1E	145
11604614	405i-140	2E	145
11604617	405i-170	2E	145
11604620	405i-200	2E	145
11605008	410-80	1E	146
11605010	410-100	1E	



CODE	ART.	CAT.	PAG.
11612018	465-180	1E	158
11612518	470-180	1E	159
11612618	470I-180	2E	159
11613018	475-180	1E	159
11613518	480-180	1E	160
11613618	480I-180	2E	160
11614018	482-180	1E	160
11614518	485-180	1E	161
11614618	485I-180	2E	161
11615018	487-180	1E	161
11647010	490-100	1E	162
11647012	490-120	1E	162
11647014	490-140	1E	162
11647110	492-100	1E	162
11647112	492-120	1E	162
11647114	492-140	1E	162
11647210	494-100	1E	162
11647215	494-150	1E	162
11647310	495-100	1E	163
11647315	495-150	1E	163
11647410	496-100	1E	163
11647415	496-150	1E	163
11648010	497-100	1E	163
11648015	497-150	1E	163
11648010 001	497Z-100	1E	163
11648015 001	497Z-150	1E	163
11648110	498-100	1E	164
11648115	498-150	1E	164
11648110 001	498Z-100	1E	164
11648115 001	498Z-150	1E	164
11618515	500-150	1E	165
11618615	500I-150	2E	164
11619015	505-150	1E	166
11619515	510-150	1E	166
11620015	515-150	1E	166
11620515	520-150	1E	167
11621015	525-150	1E	167
11621515	530-150	1E	167
11622030	550-300	1E	168
11622530	551-300	1E	168
11623030	552-300	1E	168
11628506	560-60	1E	169
11647608	560-80	1E	169
11647610	560-100	1E	169
11647612	560-120	1E	169
11647614	560-140	1E	169
11628516	560-160	1E	169
11628518	560-180	1E	169
11647710	564-100	1E	169
11647712	564-120	1E	169
11647714	564-140	1E	169
11615916	564-160	1E	169

CODE	ART.	CAT.	PAG.
11615918	564-180	1E	169
11615604	570-40	1E	169
11615606	570-60	1E	169
11615608	570-80	1E	169
11615610	570-100	1E	169
11615612	570-120	1E	169
11615614	570-140	1E	169
11616104	572-40	1E	170
11616106	572-60	1E	170
11616108	572-80	1E	170
11616110	572-100	1E	170
11616112	572-120	1E	170
11616114	572-140	1E	170
11617110	574-100	1E	170
11617115	574-150	1E	170
11617210	575-100	1E	170
11617215	575-150	1E	170
11617310	576-100	1E	171
11617314	576-140	1E	171
11617315	576-150	1E	171
11617410	577-100	1E	171
11617414	577-140	1E	171
11617415	577-150	1E	171
11648410	578-100	1E	172
11648414	578-140	1E	172
11648415	578-150	1E	172
10703005 001	590	1G	183
11623505	600-65	1G	183
11623510	600-85	1G	183
11624005	606-65	1G	183
11624010	606-85	1G	183
12207505 001	615-10	1G	184
12207510 001	615-12	1G	184
11700505 001	620	1G	184
11700595	620I	2G	184
11701005 001	625	1G	185
11701010 001	625	1G	185
11701105 001	627P	1G	185
11701110 001	627G	1G	185
11701205	628	1G	185
11701505 001	630	1G	186
11702005	635	1G	186
11702505	640	1G	186
11703005	645	1G	187
11703505	650	1G	187
11704005	655	1G	187
10904005 001	660DX	1H	188
10904010 001	660SX	1H	188
10904505 001	662	1H	188
11000400 001	671P	1H	312
11000401 503	671G	1H	312
11000300 503	672P	1H	312

CODE	ART.	CAT.	PAG.
11000301 503	672G	1H	312
11900505 001	673	1H	312
10905006 503	674	1H	313
11000505 503	675P	1H	313
11000510 503	675G	1H	313
11001005 503	677P	1H	313
11001010 503	677G	1H	313
11001505 503	678P	1H	314
11001510 503	678G	1H	314
11002505 503	679P	1H	314
11002510 503	679G	1H	314
11002610	679I	2H	314
11203005 001	680	1B	315
11203505 001	682	1B	316
10205505 001	683	1B	316
10205510 001	683	1B	316
11204005 700	684	1B	316
11204805 503	685	1B	317
11204705 503	686	1B	317
10206005 001	687	1B	317
10206010 001	687	1B	317
11205006 503	690 MC DX	3A	318
11205006 002	690 MC DX	3A	318
11205006 001	690 MC DX	3A	318
11205011 002	690 MC SX	3A	318
11205011 503	690 MC SX	3A	318
11205011 001	690 MC SX	3A	318
12001105 503	691P	3A	319
12001105 002	691P	3A	319
12001105 001	691P	3A	319
12001505 503	691G	3E	319
12001505 002	691G	3E	319
12001505 001	691G	3E	319
10203503 003	692 P-1200	3A	320
10203503 002	692 P-1200	3A	320
10203503 001	692 P-1200	3A	320
10203515 003	692 P-3000	3A	320
10203515 002	692 P-3000	3A	320
10203515 001	692 P-3000	3A	320
10203504 003	692 P-4800	3A	320
10203504 002	692 P-4800	3A	320
10203504 001	692 P-4800	3A	320
10203518 003	692 G-1200	3A	320
10203518 002	692 G-1200	3A	320
10203518 001	692 G-1200	3A	320
10203530 003	692 G-3000	3A	320
10203530 002	692 G-3000	3A	320
10203530 001	692 G-3000	3A	320
10203540 003	692 G-4800	3A	320
10203540 002	692 G-4800	3A	320
10203540 001	692 G-4800	3A	320
11207006 503	693 MC DX	3A	321

CODE	ART.	CAT.	PAG.
11207011 503	693 MC SX	3A	321
11205506 503	694 MC DX	3A	321
11205506 002	694 MC DX	3A	321
11205506 001	694 MC DX	3A	321
11205511 503	694 MC SX	3A	321
11205511 002	694 MC SX	3A	321
11205511 001	694 MC SX	3A	321
10203703 003	695 P-1200	3A	322
10203703 002	695 P-1200	3A	322
10203703 001	695 P-1200	3A	322
10203715 003	695 P-3000	3A	322
10203715 002	695 P-3000	3A	322
10203715 001	695 P-3000	3A	322
10203704 003	695 P-4800	3A	322
10203704 002	695 P-4800	3A	322
10203704 001	695 P-4800	3A	322
10203718 003	695 G-1200	3A	322
10203718 002	695 G-1200	3A	322
10203718 001	695 G-1200	3A	322
10203730 003	695 G-3000	3A	322
10203730 002	695 G-3000	3A	322
10203730 001	695 G-3000	3A	322
10203740 003	695 G-4800	3A	322
10203740 002	695 G-4800	3A	322
10203740 001	695 G-4800	3A	322
10203702 003	695 PM-1200	3A	323
10203702 002	695 PM-1200	3A	323
10203702 001	695 PM-1200	3A	323
10203701 003	695 GM-1200	3A	323
10203701 002	695 GM-1200	3A	323
10203701 001	695 GM-1200	3A	323
11206006 503	696 MC DX	3A	324
11206006 002	696 MC DX	3A	324
11206006 001	696 MC DX	3A	324
11206011 503	696 MC SX	3A	324
11206011 002	696 MC SX	3A	324
11206011 001	696 MC SX	3A	324
11206506 503	698 MC DX-50	3A	325
11206506 002	698 MC DX-50	3A	325
11206506 001	698 MC DX-50	3A	325
11206526 503	698 MC DX-80	3A	325
11206526 002	698 MC DX-80	3A	325
11206526 001	698 MC DX-80	3A	325
11206511 503	698 MC SX-50	3A	325
11206511 002	698 MC SX-50	3A	325
11206511 001	698 MC SX-50	3A	325
11206531 503	698 MC SX-80	3A	325
11206531 002	698 MC SX-80	3A	325
11206531 001	698 MC SX-80	3A	325
11003500	699	3F	323
11901005 001	700Z	1D	188
11901206 001	704-16	1D	189

CODE	ART.	CAT.	PAG.
11901211 001	704-20	1D	189
11901216 001	704-24	1D	189
11901215 001	704-24	1D	189
11901605 001	705-16	1D	189
11901610 001	705-20	1D	189
11901615 001	705-24	1D	189
11901805 001	706	1D	190
11901905 001	707	1D	190
11901705 001	708	1D	190
11902005 001	710-130	1D	191
11902010 001	710-300	1D	191
11902015 001	710-500	1D	191
11902505 001	712-130	1D	191
11902510 001	712-300	1D	191
11902515 001	712-500	1D	191
11903005 001	714-330	1D	191
11903010 001	714-660	1D	191
11903505 001	716-330	1D	192
11903510 001	716-660	1D	192
11904005 001	720-350	1D	193
11904010 001	720-450	1D	193
11904015 001	720-600	1D	193
11904020 001	720-800	1D	193
11904505 001	725-450	1D	192
11904510 001	725-600	1D	192
11904515 001	725-800	1D	192
11912001	730I	2D	192
11905005 001	735-150	1D	194
11905010 001	735-200	1D	194
11905015 001	735-250	1D	194
11905020 001	735-300	1D	194
11905025 001	735-400	1D	194
11905030 001	735-500	1D	194
11905035 001	735-600	1D	194
11905040 001	735-800	1D	194
11905205 001	737-150	1D	194
11905210 001	737-200	1D	194
11905215 001	737-250	1D	194
11905220 001	737-300	1D	194
11905225 001	737-400	1D	194
11905230 001	737-500	1D	194
11905235 001	737-600	1D	194
11905240 001	737-800	1D	194
1190550			



Indice generale degli articoli

Product index

CODE	ART.	CAT.	PAG.
11910525 005	835-600	1D	200
11910530 005	835-800	1D	200
12002505 005	837	1D	200
11911005 002	840-200	1D	201
11911010 002	840-300	1D	201
11911015 002	840-400	1D	201
11911020 002	840-500	1D	201
11911025 002	840-600	1D	201
11911035 002	840-800	1D	201
11911045 002	840-1000	1D	201
11911505 002	840D-200	1D	201
11911510 002	840D-300	1D	201
11911515 002	840D-400	1D	201
11911520 002	840D-500	1D	201
11911525 002	840D-600	1D	201
11911535 002	840D-800	1D	201
11911545 002	840D-1000	1D	201
12003005 002	852	1D	202
12003505 001	855	1D	202
12004005 001	857	1D	203
11913001 001	860	1D	203
11914001 001	862-240	1D	203
11914005 001	862-560	1D	203
11914010 001	862-560-e20	1D	203
11630405 503	A370P	3D	326
11630905 503	A371P	3D	326
11630505 503	A380P	3D	327
11630511 503	A380G	3D	326
11634005 503	A380R	3D	327
11631005 503	A381P	3D	328
11631011 503	A381G	3D	327
11632405 503	A384P	3D	328
11632505 503	A385P	3D	328
10130019 001	CGS-150.5 M	1Q	216
10130020 001	CGS-150.5 P	1Q	218
19912494	CGS-150.5 M AL	1Q	220
19912495	CGS-150.5 P AL	1Q	222
10207004	CGS-245M	1R	258
10207024	CGS-245M	1R	258
10207006	CGS-245P	1R	258
10207025	CGS-245P	1R	258
10207014	CGS-245G	1R	258
10207026	CGS-245G	1R	258
10207004 001	CGS-245M	1R	258
10207024 001	CGS-245M	1R	258
10207006 001	CGS-245P	1R	258
10207025 001	CGS-245P	1R	258
10207014 001	CGS-245G	1R	258
10207026 001	CGS-245G	1R	258
10130030 001	CGS-250.5M	1Q	224
10130031 001	CGS-250.5P	1Q	226
10130032 001	CGS-250.5G	1Q	228

CODE	ART.	CAT.	PAG.
10130003 001	CGS-250.8M	1Q	230
10130007 001	CGS-250.8P	1Q	232
10130012 001	CGS-250.8G	1Q	234
10207001	CGS-345M	1R	259
10207002	CGS-345M	1R	259
10207005	CGS-345P	1R	259
10207007	CGS-345P	1R	259
10207020	CGS-345G	1R	259
10207022	CGS-345G	1R	259
10207001 001	CGS-345M	1R	259
10207002 001	CGS-345M	1R	259
10207005 001	CGS-345P	1R	259
10207007 001	CGS-345P	1R	259
10207020 001	CGS-345G	1R	259
10207022 001	CGS-345G	1R	259
10207505	CGI-345P	1R	259
10207507	CGI-345P	1R	259
10130001 001	CGS-350.5M	1Q	236
10130005 001	CGS-350.5P	1Q	238
10130010 001	CGS-350.5G	1Q	240
10208 001	CGA-345M	1R	260
10208 003	CGA-345M	1R	260
10208 005	CGA-345P	1R	260
10208 007	CGA-345P	1R	260
10208 009	CGA-345G	1R	260
102088 001	CGA-345G	1R	260
10208001	CGA-350.5 AL M	1Q	242
10130605 001	CGA-350.5 AL P	1Q	244
10130002 001	CGS-350.8M	1Q	246
10130006 001	CGS-350.8P	1Q	248
10130011 001	CGS-350.8G	1Q	250
10130305	CGI-350.5P	1Q	252
10131005 001	CG-05P	1T	254
10131010 001	CG-05P	1T	254
10131305	CGI-05P	1T	254
10131100 001	CG-10	1T	256
10708001 001	CG-15M	1T	265
10708005 001	CG-15P	1T	265
10708010 001	CG-15G	1T	265
10707101 001	CG-20M	1T	266
10707105 001	CG-20P	1T	266
10707110 001	CG-20G	1T	266
10707001 001	CGA-20M	1T	267
10707005 001	CGA-20P	1T	267
10707010 001	CGA-20G	1T	267
10707501 001	CG-25M	1T	268
10707505 001	CG-25P	1T	268
10707510 001	CG-25G	1T	268
10707601 001	CG-30M	1S	269
10707605 001	CG-30P	1S	269
10707610 001	CG-30G	1S	269
10707705 001	CG-35P	1T	264

CODE	ART.	CAT.	PAG.
10707710 001	CG-35G	1T	264
10131400 001	CG-40	1T	270
11310005 001	CG-251	1S	271
11310305	CGI-251	1S	271
11310100 001	CG-252	1S	272
10210150 001	CG-254	1S	272
11310300 001	CG-256-40	1S	272
11310301 001	CG-256-50	1S	272
10130505 001	CG-348	1T	255
10130510 001	CG-348	1T	255
10130705	CGI-348	1T	255
10705200 001	CGA-347M	1T	263
10705205 001	CGA-347P	1T	263
10705210 001	CGA-347G	1T	263
10705501 001	CGS-346M	1T	261
10705505 001	CGS-346P	1T	261
10705510 001	CGS-346G	1T	261
10706005	CGI-346P	1T	261
10705001 001	CGS-347M	1T	262
10705005 001	CGS-347P	1T	262
10705010 001	CGS-347G	1T	262
10705305	CGI-347P	1T	262
19912326	KIT150-300B3M	1U	216
19912333	KIT150-300B6M	1U	216
19912330	KIT150-300T3M	1U	216
19912331	KIT150-300T6M	1U	216
19912324	KIT150-600B3M	1U	218
19912334	KIT150-600B6M	1U	218
19912325	KIT150-600T3M	1U	218
19912332	KIT150-600T6M	1U	218
11644015 503	P365	3D	329
11645515 503	P365 R	3D	329
11644500 503	P368 I	3D	329
11644550 503	P368 S	3D	330
11644560 503	P368 M	3D	330
11640710 503	P370	3D	330
11641210 503	P371	3D	331
11640510 503	P380	3D	331
11641010 503	P381	3D	331
11642510 503	P385	3D	332
10310701	R383-33	3E	332
10310702	R383-13.5	3E	332
10310601 001	R378	3E	333
12400526 003	400	1E	333

CONDIZIONI GENERALI DI VENDITA

1. GENERALITA'

1.1 Il presente documento si rivolge ai clienti (di seguito "Clienti") di FRATELLI COMUNELLO SPA (di seguito solo COMUNELLO) con esso si intendono rendere note le condizioni contrattuali che COMUNELLO applicherà in tutte le vendite dei propri prodotti (di seguito CONDIZIONI GENERALI DI VENDITA), salvo diverse specifiche pattuizioni in deroga a quanto qui riportato, trattasi, in ogni caso, di condizioni che risultano vincolanti ed efficaci tra le parti ai sensi dell'art. 1341 Codice Civile.

1.2. COMUNELLO applica in tutti i rapporti contrattuali di vendita dei propri prodotti la legge italiana, salvo apposite deroghe che dovranno essere concordate e provate per iscritto

1.3 Le Condizioni Generali di Vendita qui riportate si riferiscono esclusivamente ai prodotti portanti il marchio COMUNELLO (di seguito "Prodotti").

2. OFFERTE – PREVENTIVI

2.1 Le offerte formulate da COMUNELLO ai propri Clienti conservano efficacia per un periodo massimo di 20 (venti) giorni dalla data di invio delle stesse, in ogni caso dovranno essere formalizzate per iscritto, anche a mezzo mail.

2.2. Decorso tale termine l'offerta formulata da COMUNELLO dovrà ritenersi decaduta e non accettabile da parte del CLIENTE, salvo diverso specifico accordo scritto tra le parti contrattuali

3. ORDINI

3.1 Gli ordini d'acquisto sottoscritti dai Clienti ed indirizzati a COMUNELLO dovranno essere confermati mediante apposito modulo predisposto da COMUNELLO (conferma d'ordine), che ciascun Cliente dovrà ritrasmettere a quest'ultima società, indicando, con precisione, il quantitativo della merce compravenduta e le ulteriori caratteristiche dei prodotti richiesti, previa apposizione della firma.

3.2 Il contratto d'acquisto si intende perfezionato e vincolante tra le parti mediante:

a) conferma dell'ordine d'acquisto da parte di FRATELLI COMUNELLO SPA;
b) con l'esecuzione materiale dell'ordine d'acquisto da parte di FRATELLI COMUNELLO, purché rispettoso del contenuto della vendita conclusa tra le parti.

3.3 Qualsiasi modifica o integrazione di singole disposizioni delle Condizioni Generali di Vendita o dell'ordine d'acquisto sono prive di efficacia se non sono state approvate per iscritto da COMUNELLO SPA. In caso di modifiche all'ordine d'acquisto, intervenute successivamente all'inoltro del modulo indicato al punto 3.1., le stesse non potranno considerarsi efficaci se nel frattempo COMUNELLO ha accettato l'ordine o vi ha dato esecuzione anche parziale. COMUNELLO si riserva comunque il diritto di annullare l'ordine d'acquisto originario e di sospendere l'esecuzione di quello in corso, chiedendo il risarcimento dei danni.

3.4 La data di consegna dei Prodotti indicata negli ordini d'acquisto ha sempre e comunque valore indicativo e l'eventuale ritardo rispetto a tale termine, per un periodo non superiore a giorni 30, non potrà mai costituire ragione per il CLIENTE affinché questi possa avanzare pretese risarcitorie nei confronti di COMUNELLO o per risolvere il rapporto contrattuale.

In particolare COMUNELLO si riserva la facoltà di prorogare i termini di consegna per caso fortuito o forza maggiore o comunque per eventi non prevedibili al momento della conclusione della vendita (ad esempio, per difficoltà di approvvigionamenti di materie prime e componenti); qualora prima della consegna del materiale il CLIENTE versi in una situazione di difficoltà finanziaria o comunque modifichi la propria forma giuridica, COMUNELLO potrà procedere alla sospensione dell'esecuzione del rapporto contrattuale interrompendone immediatamente l'esecuzione, ed eventualmente risolvendo il contratto.-

4. CONSEGNA E SPEDIZIONE

4.1 I Prodotti vengono consegnati al CLIENTE nel luogo di produzione ovvero presso la sede legale di COMUNELLO (di seguito "Consegna").

4.2 Nel caso in cui i Prodotti siano consegnati Ex-works Rosà o Cassola (VI) INCOTERMS 2010, il passaggio del rischio si realizza dal momento della Consegna dei Prodotti da parte di FRATELLI COMUNELLO S.p.a. al Cliente od al vettore, il CLIENTE assume inoltre i costi del trasporto.

4.3 Salvo diverso accordo, FRATELLI COMUNELLO SPA stabilisce, in nome e per conto del Cliente, il tipo di spedizione, la via di trasporto e il vettore.

4.4 FRATELLI COMUNELLO SPA si riserva la facoltà di effettuare esecuzioni o Consegne parziali degli ordini d'acquisto. Il Cliente non potrà sollevare contestazione alcuna in ordine a consegne frazionate e/o parziali. Tutte le Consegne parziali verranno fatturate autonomamente ed i termini di pagamento decorreranno dalla data di ciascuna fattura. Il pagamento delle Consegne parziali non potrà essere differito all'ultimazione delle Consegne relative all'ordine d'acquisto originario. Anche in caso di consegne parziali, troverà applicazione quanto stabilito dall'articolo 4.1.

5. PREZZI E LISTINI

5.1 Per prezzo si intende quello indicato nell'ultimo listino COMUNELLO per i Prodotti consegnati al Cliente, imballaggio normale compreso, e spese di spedizione escluse (di seguito "Prezzo"). L'ultimo listino emesso da FRATELLI COMUNELLO SPA annulla tutti i listini precedenti ed, in assenza di diverse pattuizioni, sarà quello applicabile alla vendita.

6. PAGAMENTO

6.1 Il pagamento del Prezzo dovrà avvenire entro il termine pattuito tra le parti contraenti. Il mancato pagamento del Prezzo entro il termine convenuto determinerà la decorrenza di interessi per il ritardo di pagamento nelle transazioni commerciali, nella misura prevista dal D.Lgs. n. 231 del 9.10.2002 e successive modifiche ed integrazioni. Tali interessi decorreranno dalla scadenza del termine di pagamento è fatto salvo il maggior danno subito da COMUNELLO.-

6.2 Il Cliente non potrà proporre domande né formulare eccezioni nei confronti di COMUNELLO se non dopo aver provveduto al pagamento del Prezzo.

6.3 In caso di irregolarità nei pagamenti, COMUNELLO si riserva il diritto di sospendere l'esecuzione di tutti gli ordini di acquisto, anche se diversi da quelli per i quali si è verificato il ritardo o l'inadempimento da parte del CLIENTE, senza alcun preavviso né diritto di risarcimento di alcun danno da parte del CLIENTE.

7. RESI E RECLAMI

7.1 Tutti i reclami devono essere formulati per iscritto entro 8 (otto) giorni dalla ricezione dei Prodotti, siano essi relativi alla quantità o alla qualità dei Prodotti consegnati.

7.2 I resi dei Prodotti consegnati verranno accettati da FRATELLI COMUNELLO SPA soltanto previo accordo scritto ed esclusivamente con riguardo a Prodotti nuovi e completi di imballaggio originale.

7.3 I resi dovranno essere accompagnati dall'apposito documento di trasporto di reso, indicante l'autorizzazione scritta di FRATELLI COMUNELLO SPA nonché la quantità e la qualità dei Prodotti.

7.4 I resi non potranno considerarsi accettati da FRATELLI COMUNELLO SPA se non effettuati con le modalità di cui sopra ed in particolare non potrà intendersi quale accettazione di resi la presa in consegna di Prodotti presso la sede o i depositi di FRATELLI COMUNELLO SPA.

7.5 Sulla somma accreditata riferita a resi non dovuti a cause imputabili a FRATELLI COMUNELLO SPA, verrà operata una riduzione del 30% da considerarsi alla stregua di una liquidazione forfetaria del danno (clausola penale), addebitata al Cliente in ragione dei costi generali, di spedizione, deperimento della merce, vetustà etc sopportati da COMUNELLO.

8. GARANZIA

8.1 La presente garanzia nei rapporti commerciali o in caso di vendita di beni per uso professionale è limitata alla riparazione o sostituzione del pezzo del Prodotto riconosciuto da FRATELLI COMUNELLO SPA quale difettoso mediante Prodotti rigenerati equivalenti (di seguito "Garanzia Convenzionale"), non risulta compresa nella garanzia il costo necessario per le attività di riparazione e sostituzione del materiale (a titolo esemplificativo costi di manodopera, noleggio materiali, etc).-

8.2 E' esclusa l'applicazione della disciplina dettata dagli articoli 1490-1495 del Codice Civile, 8.3 FRATELLI COMUNELLO SPA garantisce il funzionamento dei Prodotti nei limiti indicati al superiore punto sub 8.1.. Salvo diverso accordo, la validità della Garanzia Convenzionale è di 24 (ventiquattro) mesi dalla data di produzione, rilevabile sui Prodotti. Per gli attuatori della linea Showin la garanzia è di 60 (sessanta) mesi dalla data di produzione, mentre per i restanti prodotti della linea Automation Frame la garanzia è di 36 (trentasei) mesi dalla data di produzione. La Garanzia risulterà efficace e vincolante per COMUNELLO solo se il prodotto verrà correttamente montato e manutentato in conformità alle regole di installazione e di sicurezza indicate nella documentazione fornita da COMUNELLO o comunque rinvenibile sul sito www.comunello.com

8.4 La garanzia non comprende: avarie o danni causati dal trasporto; avarie o danni causati da vizi dell'impianto elettrico presente presso l'acquirente il prodotto e/o da trascuratezza, negligenza, inadeguatezza, uso anomalo di tale impianto; avarie o danni dovuti a manomissioni poste in essere da parte di personale non autorizzato o conseguenti allo scorretto uso/installazione (a questo proposito, si consiglia una manutenzione del sistema almeno ogni sei mesi) o all'impiego di pezzi di ricambio non originali; difetti causati da agenti chimici e/o fenomeni atmosferici. La garanzia non comprende il costo per materiale di consumo, in ogni caso COMUNELLO matura il credito per l'intervento eseguito presso il cliente, laddove quest'ultimo si riveli inutile poiché non risultava operante la garanzia o perché il cliente aveva utilizzato il prodotto COMUNELLO in modo negligente, imprudente od imperito, tale per cui il corretto utilizzo del prodotto avrebbe potuto evitare l'installazione.-

8.5 Termini attuativi: salvo diverso accordo, il diritto alla Garanzia Convenzionale si esercita esibendo copia del documento di acquisto (fattura fiscale) a COMUNELLO. Il Cliente deve denunciare il difetto a COMUNELLO entro il termine di decadenza di 30 (trenta) giorni dalla scoperta.

L'azione deve essere esercitata entro il termine di prescrizione di 6 (sei) mesi dalla scoperta. I pezzi dei Prodotti per i quali viene richiesta l'attivazione della Garanzia Convenzionale devono essere spediti dal Cliente presso FRATELLI COMUNELLO S.p.a., Via Cassola 64, 36027 Rosà (VI) Italia.

8.6 Il Cliente non potrà richiedere il risarcimento di danni indiretti, mancati profitti, perdita di produzione ed in ogni caso non potrà pretendere a titolo di risarcimento somme superiori al valore dei componenti o dei Prodotti forniti. Tutte le spese per il trasporto dei Prodotti da riparare o riparati, anche se coperti dalla Garanzia Convenzionale, sono a carico del Cliente.

8.7 Nessun intervento esterno effettuato dal personale tecnico di COMUNELLO è coperto dalla Garanzia Convenzionale.

8.8 Modifiche specifiche delle condizioni della Garanzia Convenzionale qui descritte possono essere definite dalle parti nei propri contratti commerciali.

9. RIPARAZIONI OLTRE IL TERMINE DI GARANZIA

9.1 Le riparazioni dei Prodotti richieste dal Cliente verranno effettuate da FRATELLI COMUNELLO SPA, previo accordo sul costo dell'intervento. In ogni caso le spese per la manodopera e quelle di spedizione (andata e ritorno) rimarranno a carico del Cliente.

10. RISERVA DI PROPRIETA'

10.1 I Prodotti forniti al CLIENTE, rimangono di proprietà di FRATELLI COMUNELLO SPA fino al saldo integrale del Prezzo da parte del Cliente, indipendentemente da chi abbia la detenzione dei Prodotti. Le spese di trasporto e le altre necessarie al recupero dei Prodotti così come le spese straordinarie e quelle ripetibili, saranno a carico del Cliente.

11. BREVETTI, MARCHI E SEGNI DISTINTIVI

11.1 Il Cliente è a conoscenza del fatto che i Prodotti sono coperti da brevetti e sono oggetto di Know-How e design costituenti proprietà esclusiva di FRATELLI COMUNELLO SPA, a norma del Codice della Proprietà Industriale.

11.2 E' fatto espresso divieto al Cliente di violare tali diritti di FRATELLI COMUNELLO SPA ed in ogni caso il Cliente non potrà in alcun modo rimuovere, sopprimere o comunque alterare marchi ed altri segni distintivi o sigle di qualsiasi genere apposti ai Prodotti, così come è fatto divieto di apporne di nuovi di qualsiasi natura. E' vietata inoltre qualsiasi forma di riproduzione od utilizzo del marchio FRATELLI COMUNELLO SPA e di ogni altro segno distintivo presente sui Prodotti, salvo autorizzazione scritta di FRATELLI COMUNELLO SPA.

12. CLAUSOLA RISOLUTIVA ESPRESSA

12.1 Ai sensi e per gli effetti dell'articolo 1456 del Codice Civile, il ritardato pagamento superiore ai dieci giorni, o il mancato pagamento, anche solo parziale, del Prezzo da parte del Cliente, secondo le modalità di cui all'articolo 6 delle presenti Condizioni Generali di Vendita, comporterà la risoluzione del contratto di acquisto, con diritto per FRATELLI COMUNELLO SPA di chiedere al Cliente il risarcimento dei danni patiti, oltre alla restituzione dei Prodotti rispetto ai quali il Cliente non abbia pagato il Prezzo.

12.2 La comunicazione di cui al punto precedente sarà trasmessa tramite raccomandata A.R. o tramite Pec.

13. ACCORDI TRA LE PARTI

13.1 In caso di accordi, preesistenti o sopravvenuti, tra FRATELLI COMUNELLO SPA ed il

GENERAL TERMS OF SALE

1. GENERAL INFORMATION

1.1 This document is intended for customers (hereinafter “Customers”) of FRATELLI COMUNELLO SPA (hereinafter simply COMUNELLO); its purpose is to inform customers about the contractual conditions that COMUNELLO shall apply in all the sales of its products (hereinafter GENERAL TERMS AND CONDITIONS OF SALE), unless otherwise agreed in writing, and which, in any case, are binding on and effective between the parties pursuant to art. 1341 of the Italian Civil Code.

1.2. COMUNELLO applies the Italian law in all contractual relationships involving the sale of its products, save for any specific derogations to be agreed and proved in writing.

1.3 The General Terms and Conditions of Sale listed here exclusively refer to products bearing the COMUNELLO trademark (hereinafter the “Products”).

2. OFFERS – QUOTES

2.1 The offers made by COMUNELLO to its Customers are effective for a maximum period of 20 (twenty) days from their submission; in any case they will have to be formalized in writing, including by email.

2.2. Upon expiry of the aforementioned deadline, the offer made by COMUNELLO shall be deemed cancelled and not acceptable by the CUSTOMER, unless otherwise specifically agreed in writing between the contracting parties

3. ORDERS

3.1 Purchase orders signed by the Customers and addressed to Comunello must be confirmed using the specific form prepared by Comunello (order confirmation), which each Customer has to sign and return to Comunello, precisely specifying the quantity of the goods bought and any additional features of the requested products.

3.2 The purchase contract shall be considered finalized and binding on the parties by means of:

a) confirmation of the purchase order by FRATELLI COMUNELLO SPA;

b) physical execution of the purchase order by FRATELLI COMUNELLO SPA, provided it is in compliance with the contents of the sale entered into between the parties.

3.3 Any amendment or addition to the individual provisions of the General Terms and Conditions of Sale or to the purchase order shall be ineffective unless approved in writing by COMUNELLO SPA. In the event changes are made to the purchase order after sending the form specified in paragraph 3.1., they shall have no effect if in the meantime Comunello has accepted the order or has implemented it in part; in any event, Comunello reserves the right to cancel the original purchase order and to suspend performance of the current one, requesting damages.

3.4 The Product delivery date specified in the purchase orders is always indicative and any delay of up to 30 days with respect to such deadline shall never constitute grounds for the CUSTOMER to claim damages against Comunello or to terminate the contractual relationship.

More specifically, Comunello reserves the right to extend the delivery date due to unforeseeable circumstances or force majeure or in any case for circumstances that could not be foreseen at the time of the sale (for example, difficulty in procurement of raw materials and components); if prior to delivery, the CUSTOMER is in a difficult financial situation or changes its legal form, Comunello shall be entitled to suspend performance of, and possibly terminate the contract.

4. DELIVERY AND SHIPPING

4.1 The Products are delivered to the Customer at the production site or at the registered office of Comunello (hereinafter “Delivery”).

4.2 If the Products are delivered Ex-works Rosà or Cassola (VI) Incoterms 2010, the risk is transferred upon delivery of the Products by FRATELLI COMUNELLO SPA to the Customer or to the carrier, the CUSTOMER being in charge of the transportation costs.

4.3 Unless otherwise agreed, FRATELLI COMUNELLO SPA shall establish, in the name and on behalf of the Customer, the type of shipment, the transport route and the carrier.

4.4 FRATELLI COMUNELLO SPA reserves the right to partially fulfil the purchase order or to partially deliver the products ordered. The Customer cannot raise any objection with regard to partial deliveries and/or deliveries made by instalments. All Partial deliveries shall be invoiced individually and the payment time limits shall run from the date of each invoice. The payment of partial Deliveries may not be deferred until completion of all the Deliveries related to the original purchase order. The provisions of Article 4.1 shall also apply to partial deliveries.

5. PRICES AND PRICE LISTS

5.1 The price is as specified in the last Comunello price list for the products delivered to the Customer, including normal packaging and excluding shipping costs (hereinafter the “Price”). The last price list issued by FRATELLI COMUNELLO SPA cancels all previous price lists and, unless otherwise agreed, it shall be applicable to the sale.

6. PAYMENT

6.1 Payment of the Price has to be made within the time limit agreed between the contracting parties. Failure to pay the price within the agreed time limit shall result in the application of interest for late payment in commercial transactions, to the extent provided by Legislative Decree No. 231 of 9.10.2002 as amended and supplemented. Default interest shall run from the expiry of the payment due date, subject to COMUNELLO's right to seek compensation for any further damage.

6.2 The Customer may not make claims or raise objections against Comunello until the Price has been paid.

6.3 In the event of irregular payments, Comunello reserves the right to suspend the performance of all purchase orders, including those not affected by the delay or default by the CUSTOMER, without notice and with no right to compensation for the CUSTOMER.

7. RETURNS AND COMPLAINTS

7.1 Any complaints referring to either the quantity or the quality of the delivered Products must be made in writing within 8 (eight) days from receipt of the Products.

7.2 The Products returned shall be accepted by FRATELLI COMUNELLO SPA only after written agreement and exclusively with regard to new Products with their original packaging.

7.3 The Products must be returned using the appropriate transport document specifying the written permission of FRATELLI COMUNELLO SPA as well as the quantity and quality of the Products.

7.4 Returns shall not be considered accepted by FRATELLI COMUNELLO SPA unless they are returned in the manner specified above and, specifically, taking delivery of the Products at the headquarters or at the warehouses of FRATELLI COMUNELLO SPA may not be construed as acceptance of the returns.

7.5 The amount credited for returns not due to causes attributable to FRATELLI COMUNELLO SPA, shall be subject to a 30% deduction, to be regarded as a flat-rate assessment of the damage (penalty clause), charged to the Customer on account of the general, shipping, goods deterioration, age etc. costs incurred

by COMUNELLO.

8. WARRANTY

8.1 In business relationships or in case of products sold for professional use, this warranty is limited to the repair or replacement of product parts that FRATELLI COMUNELLO SPA acknowledges as defective, through equivalent re-manufactured Products (the “Conventional Warranty”); the warranty does not include the costs necessary for repairing or replacing the material (e.g. labour costs, rental of equipment etc) .-

8.2 The provisions contained in articles 1490 to 1495 of the Italian Civil Code shall not apply.

8.3 FRATELLI COMUNELLO SPA warrants the proper operation of the products within the limits indicated in 8.1 above. Unless otherwise agreed, the validity of the Conventional Warranty is 24 (twenty four) months from the production date, which can be found on the products. For actuators of the Showin line the warranty is 60 (sixty) months from the production date, while for the remaining products of the Automation Frame Line the warranty is 36 (thirty six) months from the production date. The Warranty shall be effective and binding on COMUNELLO only if the product has been correctly installed and maintained in accordance with the installation and safety rules set out in the documentation provided by COMUNELLO or otherwise available on the website www.comunello.com

8.4 The warranty does not cover: failures or damage caused by transport; failures or damage caused by defects in the electrical system of the buyer and/or by carelessness, negligence, inadequate or abnormal use of such system; failure or damage due to tampering carried out by unauthorized personnel or due to incorrect use / installation (in this regard, system maintenance at least every six months is recommended) or the use of non-original spare parts; defects caused by chemical agents and/or atmospheric phenomena. The warranty does not cover the cost of consumables; in any event, COMUNELLO shall be entitled to a consideration for the work performed at the Customer, where such work proves useless as the warranty did not apply or because the customer had used the Comunello product in a negligent, reckless or incompetent manner, such that the proper use of the product could have avoided the work.

8.5 Implementation terms: unless otherwise agreed, the right to the Conventional Warranty is exercised by showing a copy of the purchase document (invoice) to COMUNELLO. Any defect must be notified to COMUNELLO within the time limit of thirty (30) days from detection of the defect.

The action must be exercised within the limitation period of 6 (six) months from detection of the defect.

The Product parts for which the Customer requests application of the Conventional Warranty must be returned by the Customer to FRATELLI COMUNELLO SPA, Via Cassola 64, 36027 Rosà (VI) Italy.

8.6 The Customer cannot claim compensation for indirect damage, loss of profits, loss of production and in any case it cannot claim compensation for an amount that exceeds the value of the supplied components or products. All transport costs for Products that have been repaired or to be repaired, although covered by the Conventional Warranty, shall be charged to the Customer.

8.7 No external work carried out by Comunello technical staff is covered by the Conventional Warranty.

8.8 Specific amendments to the Conventional Warranty conditions described herein can be defined by the parties in their commercial contracts.

9. REPAIRS AFTER EXPIRATION OF THE WARRANTY

9.1 The Product repairs requested by the Customer shall be carried out by FRATELLI COMUNELLO SPA, subject to prior agreement on the cost of the work. In any case, labour and transport costs (return) shall be charged to the customer.

10. RESERVATION OF TITLE

10.1 The Products delivered to the CUSTOMER shall continue to be the property of FRATELLI COMUNELLO SPA until full payment of the Price by the Customer, regardless of who has possession of the Products. Transport costs and other costs necessary to recover the Products as well as extraordinary expenses and those that can be recovered, shall be charged to the Customer.

11. PATENTS, TRADEMARKS AND DISTINCTIVE MARKS

11.1 The Customer is aware that the Products are covered by patents and incorporate know-how and design that are the exclusive property of FRATELLI COMUNELLO SPA, pursuant to the Italian Industrial Property Code.

11.2 The Customer is expressly forbidden from infringing such FRATELLI COMUNELLO SPA's rights; in any case, the Customer may not in any way remove, delete or otherwise alter the trademarks or other signs or distinctive marks of any kind affixed to Products; the Customer is likewise forbidden from affixing new ones of any kind. Any form of reproduction or use of the FRATELLI COMUNELLO SPA trademark and of any other distinctive mark on the Products is forbidden, without written authorization by FRATELLI COMUNELLO SPA.

12. EXPRESS TERMINATION CLAUSE

12.1 Pursuant to article 1456 of the Italian Civil Code, any delay of more than ten days in the payment, or any non-payment of the Price, including partial, by the Client, as provided for in Article 6 of these General Terms and Conditions of Sale, shall result in termination of the purchase contract and FRATELLI COMUNELLO SPA shall be entitled to seek compensation from the Customer for the damage suffered, in addition to restitution of the Products not paid by the Customer.

12.2 The notice referred to in the previous paragraph shall be sent by registered mail with return receipt or via certified email address (Pec).

13. AGREEMENT BETWEEN THE PARTIES

13.1 Any agreements, existing or that will take place between FRATELLI COMUNELLO SPA and the Customer, in relation to returns and payment methods, shall prevail over the provisions of these General Terms and Conditions of Sale.

14. APPLICABLE LAW AND JURISDICTION

14.1 The purchase contracts entered into in accordance with the General Terms and Conditions of Sale are subject to Italian law only, with the exclusion of any other legislation.

14.2 All disputes that may arise on the mentioned purchase contracts shall be subject to Italian jurisdiction and referred to the exclusive competence of the Court of Vicenza, including if the agreed payment method is by bank collection order or draft payable at the customer's.

(Italy). The content of this catalogue is subject to change at any time and without notice by FRATELLI COMUNELLO SPA.

NOTES



L'azienda è attenta al rispetto dell'ambiente e a tutte le tematiche inerenti la sicurezza sul lavoro e la tutela della salute di tutti i suoi lavoratori. Inoltre, per una maggiore garanzia e controllo della qualità del prodotto, l'Azienda gestisce un sistema di gestione conforme alle norme UNI EN ISO 9001:2008 certificato dal TÜV SÜD / *The Company takes its environmental responsibilities seriously and is committed to respecting Health and Safety laws so as to provide a safe working environment for its employees. Furthermore, in order to provide a further guarantee and greater control over the quality of the products, the Company uses a management system in line with UNI EN ISO 9001:2008 standards as certified by TÜV SÜD.*

Le immagini, i disegni tecnici e le relative specifiche appartengono a Fratelli Comunello SpA e sono protetti dalle leggi sul copyright. Ogni utilizzo non espressamente autorizzato sarà perseguito legalmente. Le specifiche dei prodotti sono soggette a cambiamenti senza preavviso. Possono essere richiesti su specifiche del cliente articoli con altre misure oppure a disegno. Foto immagini e disegni sono puramente indicativi. Fratelli Comunello SpA si riserva il diritto di apportare qualsiasi tipo di variazione, anche senza preavviso, al fine di aggiornare e migliorare il catalogo in qualsiasi momento. Fratelli Comunello SpA non risponde per eventuali errori tipografici o descrizioni errate di prodotti e caratteristiche tecniche.

All images, technical drawings and specifications are the exclusive property of Fratelli Comunello SpA and are protected by International Copyright laws. Any unauthorised use will result in legal proceedings. Fratelli Comunello SpA reserves the right to alter technical specifications at any time without notice. Clients may request bespoke products of different sizes and/or based on customised designs. All photographs and other images shown are for informational purposes only. Fratelli Comunello SpA reserves the right to make any kind of alteration, at any time and without prior notice so as to update and improve the catalogue. Fratelli Comunello SpA is not liable for any errors or other mistakes in the technical descriptions and technical characteristics of the products shown.

HELP DESK **+39 0424 585 111**

CONSULENZA TECNICA IN CANTIERE
PROFESSIONAL ON-SITE TECHNICAL SERVICE

TECHNICAL INFORMATION
www.comunello.com

FRATELLI COMUNELLO S.P.A.

HEADQUARTERS

Via Zarpellon, 33
36027 San Giuseppe di Cassola, Vicenza, Italy
Tel. +39 0424 585111 Fax +39 0424 533417
info@comunello.it www.comunello.com

REGISTERED OFFICE

Via Cassola,64 - C.P.79
36027 Rosà, Vicenza, Italy
Tel. +39 0424 585111 Fax +39 0424 533417
info@comunello.it www.comunello.com



Life
made
easy

