

SMART SOLUTION

Patented

DIMENTICA LE CHIAVI FORGET THE KEYS

 **SECUREMME**
SERRATURE DI SICUREZZA
www.securemme.it 

D-SMART 2.0
Make your lock motorized

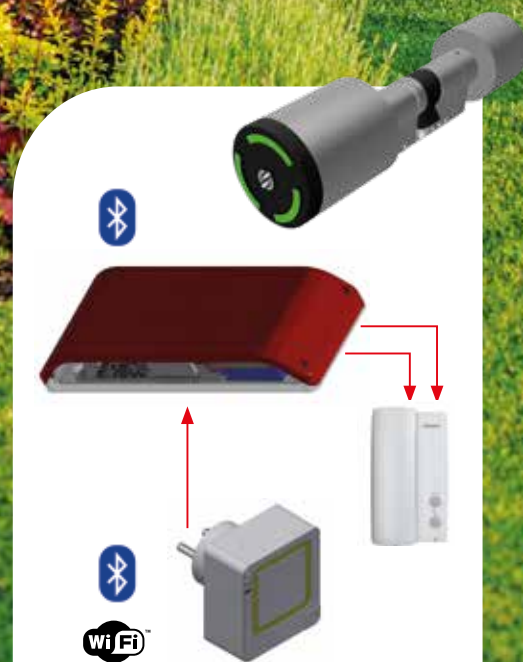

DIMENTICA LE CHIAVI, utilizza smartphone e i dispositivi wireless dedicati, per creare ed inviare codici temporanei da qualsiasi dispositivo mobile e aprire anche da remoto

FORGET THE KEYS, use smartphones and dedicated wireless devices to create and send temporary codes from any mobile device and you can also open the door remotely

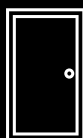

Possono essere installati su **QUALUNQUE TIPO DI ACCESSO**

They can be installed on ANY TYPE OF ACCESS

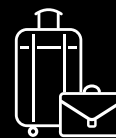

Soluzioni ideali per la tua **CASA**, per gestire gli spazi **BUSINESS** e il mondo dell'**HOSPITALITY** (B&B, affittacamere)

Ideal solutions for your HOME, to manage BUSINESS and - above all - the world of HOSPITALITY (B&B, rental apartments)

Dsmart è un dispositivo brevettato, una "smart lock motorizzata", che permette l'apertura e la chiusura automatica della serratura attraverso vari dispositivi, senza usare la chiave. Compatibile per tutte le serrature a cilindro europeo con codolo Ø 8mm.

Dimensioni 144 x 67 x 55 mm da applicare e facile da installare con possibilità di montaggio in diverse angolazioni: 0°, 90°, 180°.

Funzione Automatic Lock: chiusura automatica di tutte le mandate della serratura.

Tecnologia Bluetooth BT (5.0 BLE) con portata ≤10 m dipendenti dalle condizioni edilizie.

Crittografia: Advanced Encryption Standard AES-128.

App D-Smart 2.0 gratuita per iOS & Android per gestire e programmare fino a 150 utenti.

Temperatura di utilizzo: da -10 a +45 °C.

Certificazione CE.

La chiave meccanica è utilizzabile in caso di emergenza, per batteria scarica o in mancanza di corrente.

Dsmart is a patented device, a "motorized smart lock", which allows the automatic opening and closing of the lock through various devices, without using the key. Compatible with all European cylinder locks with knob-predisposition Ø 8mm.

Version to apply, easy to install with dimensions 144 x 67 x 55 mm and possibility of setting in different position: 0°, 90°, 180°.

Automatic Lock Function: automatic locking of all turns by closing the door.

Technology (5.0 BLE) with range ≤10m depending on building conditions.

Encryption: Advanced Encryption Standard AES-128.

Free D-Smart 2.0 App for iOS & Android to manage and program up to 150 users.

Advised temperature range for installation: from -10 to +45 °C.

Certification CE.

The key can be used in case of emergency due to low battery or in the event of a power failure.



Patented



Codice Code	Descrizione Description	Finitura Finishing	g
8100XAG	Smart lock a batteria da applicare sul lato interno porta senza forature e cablaggi. Apertura/chiusura con Smartphone.	AG	923
8100XBK		BK	923
8100XBR	Battery-powered smart lock to be applied on the inside of the door without drilling and wiring. Opening / closing with Smartphone.	BR	923
8100XWH		WH	923



> **Batteria:** integrata al litio ricaricabile. Durata delle batterie stimata 6 mesi. Ricarica completa con caricabatterie in 6 ore. Notifica per batteria scarica tramite led e smartphone.

> **Battery:** integrated rechargeable lithium battery. Battery life estimated 6 months. Full charge in 6 hours. Low battery notification via led and smartphone.



8100XAG

> **Accessori optional:** vedi categoria PLUS.

> **Contenuto della confezione:**

Dsmart Lock 2.0 con piastra di fissaggio, batteria integrata con pomolo, dima di taglio codolo cilindro, giunto prolunga codolo cilindro, carica batterie, sensore magnete a filo da incasso, sensore magnete adesivo.

> **Optional accessories:** See PLUS category.

> **Package contents:**

Dsmart Lock 2.0 with fixing plate, integrated battery with knob. Cutting template for cylinder knob-predisposition. Cylinder knob-predisposition extension device. Battery charger. Flush-mounted magnet sensor. Adhesive magnet sensor.

Codice Code	Descrizione Description	Finitura Finishing	g
8110XAG	Smart lock da applicare, alimentata da rete elettrica.	AG	1170
8110XBK	Apertura/chiusura con smartphone. Applicare sul lato interno della porta senza forature ma necessita di cablaggi.	BK	1170
8110XBR		BR	1170
8110XWH	Smart lock to apply, mains powered. Opening/closing with smartphone. To apply on the internal side of the door without drilling but requires wiring.	WH	1170



> **Caratteristiche di alimentazione:** ingresso AC 100-240 VAC; uscita 4,2 VDC da utilizzare solo con alimentatore in dotazione. Possibilità di interfaccia alla domotica di casa: Contatto smart relè b - Contatto pulito (collegamento citofono/ pulsante).

> **Power supply characteristics:** AC input 100-240 VAC; 4.2 VDC output to be used only with included power supply. Possibility of interfacing with home automation: Smart contact relay b - Clean contact (interphone / button connection).



8110XAG

> **Accessori optional:** vedi categoria PLUS.

> **Contenuto della confezione:**

Dsmart Lock 2.0 con piastra di fissaggio e pomolo, dima di taglio codolo cilindro, giunto prolunga codolo, passacavo, alimentatore, cavo alimentatore, sensore magnete a filo da incasso e N. 2 sensori magnete adesivo.

> **Optional accessories:** See PLUS category.

> **Package contents:**

Dsmart Lock 2.0 with fixing plate and knob. Cutting template for cylinder knob-predisposition. Cylinder knob-predisposition extension device. Passer-by cable. Power supply. Power supply cable. Flush-mounted magnet sensor. N. 2 adhesive magnet sensors.

Dsmart è un dispositivo brevettato, una "smart lock motorizzata", che permette l'apertura e chiusura automatica della serratura attraverso vari dispositivi, senza usare la chiave. Compatibile per tutte le serrature a cilindro europeo con codolo Ø 8mm.

Dimensioni placca metallica 119 x 68 x 16 mm da incassare, con possibilità di montaggio in diverse angolazioni: 0°, 90°, 180°.

Funzione Automatic Lock: chiusura automatica di tutte le mandate della serratura.
Tecnologia bluetooth BT (5.0 BLE) con portata ≤10 m dipendenti dalle condizioni edilizie.

Crittografia: Advanced Encryption Standard AES-128.
App D-Smart 2.0 gratuita per iOS&Android per gestire e programmare fino a 150 utenti.

Temperatura di utilizzo: da -10 a +45 °C.

Certificazione CE.

La chiave è utilizzabile in caso di emergenza per batteria scarica o in mancanza di corrente.

Dsmart is a patented device, a "motorized smart lock", which allows the automatic opening and closing of the lock through various devices, without using the key.

Compatible with all European cylinder locks with knob-predisposition Ø 8mm.

Recessed model in the panel door with metallic plate 119 x 68 x 16 mm possibility of setting in different position: 0°, 90°, 180°.

Automatic Lock Function: automatic locking of all turns by closing the door.

Bluetooth BT technology (5.0 BLE) with range ≤10m depending on building conditions.

Encryption: Advanced Encryption Standard AES-128. Free

D-Smart 2.0 App for iOS & Android to manage and program up to 150 users.

Advised temperature range for installation: from -10 to +45 °C.

Certification CE.

The key can be used in case of emergency due to low battery or in the event of a power failure.



Codice Code	Descrizione Description	Finitura Finishing	g
8120XCL	Smart lock da incassare con placca metallica sul lato interno porta con foratura pannello 50x100 mm e batteria ad incasso Ø 46 mm . Apertura/chiusura con Smartphone.	CL	923
8120XCS		CS	923
8120XOB		OB	923
8120XOL		OL	923
	Recessed smart lock with metallic plate on the internal side of the door, with panel drilling 50x100 mm and built-in battery Ø 46 mm . Opening/closing with Smartphone.		



> **Batteria** ad incasso al litio ricaricabile. Durata delle batterie stimata 6 mesi. Ricarica completa con caricabatterie in 6 ore. Notifica per batteria scarica tramite led e smartphone.

> **Battery:** integrated rechargeable lithium battery. Battery life estimated 6 months. Full charge with charger in 6 hours. Low battery notification with led and smartphone.



8120XCS

> **Accessori optional:** vedi categoria PLUS.

> **Contenuto della confezione:**

Dsmart 2.0, pomolo, carica batterie, batteria ad incasso, kit piastrina 4300 per batteria, sensore magnete a filo da incasso, 2 sensori magnete adesivo.

> **Optional accessories:** See PLUS category.

> **Package contents:**

Dsmart 2.0, knob, battery charger, battery, 4300 plate kit for battery, recessed magnet sensor with cable, 2 adhesive magnet sensors.

Codice Code	Descrizione Description	Finitura Finishing	g
8130XCL	Smart lock da incassare con placca metallica alimentata da rete elettrica. Applicare sul lato interno della porta con foratura pannello 50x100 mm e necessita di cablaggi. Apertura/ chiusura con smartphone.	CL	1170
8130XCS		CS	1170
8130XOB		OB	1170
8130XOL		OL	1170
	Recessed smart lock with metallic plate electrically powered. Apply on the internal side of the door with panel drilling 50x100 mm and necessity of wiring. Opening/closing with smartphone.		



> **Caratteristiche di alimentazione:** ingresso AC 100-240 VAC; uscita 4,2 VDC da utilizzare solo con alimentatore in dotazione. Possibilità di interfaccia alla domotica di casa: Contatto smart relè b - Contatto pulito (collegamento citofono/ pulsante).

> **Power supply characteristics:** AC input 100-240 VAC; 4.2 VDC output to be used only with supplied power supply. Possibility of interfacing with home automation: Smart relay contact b - Clean contact (intercom / button connection).

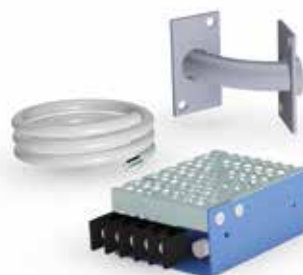

8130XCS

> **Contenuto della confezione:**

Dsmart 2.0, pomolo, passacavo, alimentatore, cavo alimentatore, sensore magnete a filo da incasso, 2 sensori magnete adesivo.

> **Package contents:**

Dsmart 2.0, knob, passing tool for cable, power supply, cable, 2 adhesive magnet sensors.

Dsmart è un dispositivo brevettato, una "smart lock motorizzata" che permette l'apertura e chiusura automatica della serratura attraverso vari dispositivi, senza usare la chiave. Compatibile per tutte le serrature a cilindro europeo con codolo Ø 8mm.

Dimensione placca maniglia in nylon 230 x 65 x 20 mm e interasse 85 mm, da incassare.

Funzione Automatic Lock: chiusura automatica di tutte le mandate della serratura.
Tecnologia Bluetooth BT (5.0 BLE) con portata ≤10 m dipendenti dalle condizioni edilizie.
Crittografia: Advanced Encryption Standard AES-128.
App D-Smart 2.0 gratuita per iOS & Android per gestire e programmare fino a 150 utenti.
Temperatura di utilizzo: da -10 a +45 °C.
Certificazione CE.

La chiave è utilizzabile in caso di emergenza per batteria scarica o in mancanza di corrente.

Dsmart is a patented device, a "motorized smart lock", which allows the automatic opening and closing of the lock through various devices, without using the key. Compatible with all European cylinder locks with knob-predisposition Ø 8mm.

Recessed model, with nylon handle plate 230 x 65 x 20 mm interspace 85 mm.

Automatic Lock Function: automatic locking of all turns by closing the door.
Bluetooth BT technology (5.0 BLE) with range ≤10m depending on building conditions.
Encryption: Advanced Encryption Standard AES-128.
Free D-Smart 2.0 App for iOS & Android to manage and program up to 150 users.
Advised temperature range for installation: from -10 to +45 °C.
Certification CE.

The key can be used in case of emergency due to low battery or in the event of a power failure.



Patented



Codice Code	Descrizione Description	Finitura Finishing	g
8140XAG	Smart lock da incassare con placca maniglia sul lato interno porta e batteria estraibile. Apertura/chiusura con Smartphone.	AG	1000
8140XBK		BK	1000
8140XBR	Recessed smart lock with handle plate on the internal side of the door and removable battery. Opening/closing with Smartphone.	BR	1000
8140XWH		WH	1000



> **Batteria:** batteria estraibile al litio ricaricabile. Durata delle batterie stimata 6 mesi. Ricarica completa con caricabatterie in 6 ore. Notifica per batteria scarica tramite led e smartphone.

> **Battery:** rechargeable removable lithium battery. Battery life estimated 6 months. Full charge with charger in 6 hours. Low battery notification with led and smartphone.

> **Accessori optional:** vedi categoria PLUS.

> **Contenuto della confezione:**

Dsmart 2.0, carica batterie, maniglia, pomolo, sensore magnete a filo da incasso, n. 2 sensori magnetici adesivi.

> **Optional accessories:** See PLUS category.

> **Package contents:**

Dsmart 2.0, handle, knob, battery charger, battery, recessed magnet sensor with cable, 2 adhesive magnet sensors.



8140XAG

Codice Code	Descrizione Description	Finitura Finishing	g
8150XAG	Smart lock da incassare con placca maniglia in nylon alimentata da rete elettrica. Applicare sul lato interno della porta e necessita di cablaggi. Apertura/ chiusura con smartphone.	AG	1000
8150XBK		BK	1000
8150XBR		BR	1000
8150XWH	Recessed smart lock with metallic handle plate, electrically powered. Apply on the internal side of the door with necessity of wiring. Opening/closing with smartphone.	WH	1000



> **Caratteristiche di alimentazione:** ingresso AC 100-240 VAC; uscita 4,2 VDC da utilizzare solo con alimentatore in dotazione. Possibilità di interfaccia alla domotica di casa: Contatto smart relè b - Contatto pulito (collegamento citofono/ pulsante).

> **Power supply characteristics:** AC input 100-240 VAC; 4.2 VDC output to be used only with supplied power supply. Possibility of interfacing with home automation: Smart relay contact b - Clean contact (intercom / button connection).



8150XAG

> **Contenuto della confezione:**

Dsmart 2.0, passacavo, alimentatore, cavo alimentatore, maniglia, pomolo, sensore magnete a filo da incasso, n. 2 sensori magnetici adesivi.

> **Package contents:**

Dsmart 2.0, passing tool for cable, power supply, cable, handle, recessed magnet sensor with cable, 2 adhesive magnet sensors,

Dsmart è un dispositivo brevettato, una "smart lock motorizzata", che permette l'apertura e chiusura automatica della serratura attraverso vari dispositivi, senza usare la chiave. Compatibile per tutte le serrature a cilindro europeo con codolo Ø 8mm.

Dimensione placca maniglia metallica 187 x 65 x 8 mm e interasse maniglia 85 mm, da incassare.

Funzione Automatic Lock: chiusura automatica di tutte le mandate della serratura.
Tecnologia Bluetooth BT (5.0 BLE) con portata ≤10 m dipendenti dalle condizioni edilizie.
Crittografia: Advanced Encryption Standard AES-128.
App D-Smart 2.0 gratuita per iOS&Android per gestire e programmare fino a 150 utenti.
Temperatura di utilizzo: da -10 a +45 °C.
Certificazione CE.

La chiave è utilizzabile in caso di emergenza per batteria scarica o in mancanza di corrente.

Dsmart is a patented device, a "motorized smart lock", which allows the automatic opening and closing of the lock through various devices, without using the key. Compatible with all European cylinder locks with knob-predisposition Ø 8mm.

Recessed model, with metallic handle plate 187 x 65 x 8 mm interspace 85 mm.

Automatic Lock Function: automatic locking of all turns by closing the door.
Bluetooth BT technology (5.0 BLE) with range ≤10m depending on building conditions.
Encryption: Advanced Encryption Standard AES-128
Free D-Smart 2.0 App for iOS & Android to manage and program up to 150 users.
Advised temperature range for installation: from -10 to +45 °C.
Certification CE.

The key can be used in case of emergency due to low battery or in the event of a power failure.



Patented



Codice Code	Descrizione Description	Finitura Finishing	
8160XCL	Smart lock da incassare con placca maniglia metallica sul lato interno porta e batteria da incasso Ø 46 mm.	CL	1000
8160XCS		CS	1000
8160XOB	Recessed smart lock with battery Ø 46 mm and metallic handle plate on the internal side of the door. Opening/closing with Smartphone.	OB	1000
8160XOL		OL	1000



> **Batteria** da incasso al litio ricaricabile. Durata delle batterie stimata 6 mesi. Ricarica completa con caricabatterie in 6 ore. Notifica per batteria scarica tramite led e smartphone.

> **Battery:** Rechargeable removable lithium battery. Battery life estimated 6 months. Full charge with charger in 6 hours. Low battery notification with led and smartphone.



8160XCS

> **Accessori optional:** vedi categoria PLUS.

> **Contenuto della confezione:**

Dsmart 2.0, carica batterie, batteria ad incasso, kit piastrina 4300 per batteria, maniglia, pomolo, sensore magnete a filo da incasso, sensore magnete adesivo.

> **Optional accessories:** See PLUS category.

> **Package contents:**

Dsmart 2.0, handle, knob, kit 4300 escutcheon for battery, battery charger, battery, recessed magnet sensor with cable, adhesive magnet sensors.

Codice Code	Descrizione Description	Finitura Finishing	
8170XCL	Smart lock da incassare con placca maniglia metallica alimentata da rete elettrica.	CL	1240
8170XCS		CS	1240
8170XOB	Recessed smart lock with metallic handle plate electrically powered. Apply on the internal side of the door, needs wiring. Opening/closing with smartphone.	OB	1240
8170XOL		OL	1240



> **Caratteristiche di alimentazione:** ingresso AC 100-240 VAC; uscita 4,2 VDC da utilizzare solo con alimentatore in dotazione. Possibilità di interfaccia alla domotica di casa: Contatto smart relè b - Contatto pulito (collegamento citofono/ pulsante).

> **Power supply characteristics:** AC input 100-240 VAC; 4.2 VDC output to be used only with supplied power supply. Possibility of interfacing with home automation: Smart relay contact b - Clean contact (intercom / button connection).

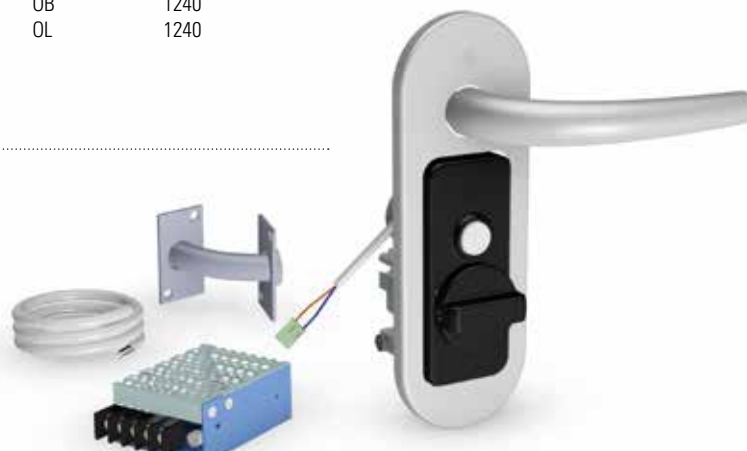

8170XCS





> **Contenuto della confezione:**

Dsmart, passacavo, alimentatore, cavo alimentatore, maniglia, pomolo, sensore magnete a filo da incasso, 2 sensori magnetici adesivi.

> **Package contents:**

Dsmart 2.0, passing tool for cable, power supply, cable, handle, knob, recessed magnet sensor with cable, 2 adhesive magnet sensors.

Codice Code	Descrizione Description	 g
8190XBK	<p>Tastiera elettronica DUE in UNO: Apertura con codice numerico e transponder Mifare Classic. APP D-SMART 2.0 per gestire fino a 150 utenti con fasce orarie differenti e personalizzabili. Collegamento con D-Smart tramite cavo CT8190XXXTA di 1 m. Posizionabile sul pannello esterno della porta.</p> <p>8190XBK Electronic keyboard TWO in ONE: <i>Opening with numeric code and Mifare Classic transponder. D-SMART 2.0 APP to manage up to 150 users with different and customizable times. Connection with D-Smart via 1 m CT8190XXXTA cable. To an be placed on the outer door panel.</i></p> <ul style="list-style-type: none"> Creazione codici virtuali per aperture a distanza: Off-line tramite Guest-key e On-line tramite Bridge. Creation of virtual codes for remote opening: Off-line via Guest-key and On-line via Bridge. <p>DOTAZIONE STANDARD EQUIPMENT 1 transponder criptato Mifare Classic - 1 cavo CT8190XXXTA. 1 Mifare Classic encrypted transponder - 1 CT8190XXXTA cable.</p>	100

D-SMART
Make your lock motorized
ON BRIDGE LINE

D-SMART
Make your lock motorized
GUEST KEY
OFF LINE



Optional: In abbinamento ordinare uno dei seguenti articoli: 4300 - 4350 - 4380 - 4400
Optional: In combination, order one of the following items: 4300 - 4350 - 4380 - 4400

Finiture disponibili Available finishing

CL

CS

OB

OL

F1

F3

F4

F5

Esempio/for example **4300K CS** ↑





CS

4350K CS

4380K CS

4440K CS

8191XBK	<p>Tastiera elettronica wireless touch retroilluminata. Comunicazione bluetooth 5.0 BLE tramite APP D-SMART 2.0 per gestire fino a 150 utenti con fasce orarie differenti e personalizzabili. Durata stimata circa 8 mesi (10 aperture giorno) con notifica di batteria scarica. Optional con possibilità di alimentarla tramite D-Smart (rimuovendo le batterie). Ordinare a parte il cavo CT8101XXXTA. Posizionabile ovunque nel raggio di 1 m.</p> <p>Bluetooth 5.0 BLE wireless backlit touch keyboard. <i>Bluetooth 5.0 BLE communication via D-SMART 2.0 APP to manage up to 150 users with different and customizable times. Estimated duration about 8 months (10 openings day) with low battery notification. Optional with the possibility of powering via D-Smart (removing the batteries). Order CT8101XXXTA cable separately Can be positioned anywhere within 1 m.</i></p> <ul style="list-style-type: none"> Creazione codici virtuali per aperture a distanza: Off-line tramite Guest-key e On-line tramite Bridge. Creation of virtual codes for remote opening: Off-line via Guest-key and On-line via Bridge. <p>DOTAZIONE STANDARD EQUIPMENT 2 batterie AAA 2 AAA batteries</p>	115
----------------	---	-----







D-SMART
Make your lock motorized
ON BRIDGE LINE

D-SMART
Make your lock motorized
GUEST KEY
OFF LINE



8192XBK	<p>Letture trasponder Mifare Classic Wireless. Comunicazione bluetooth 5.0 BLE tramite APP D-SMART 2.0 per gestire fino a 150 utenti con fasce orarie differenti e personalizzabili. No Touch System: per aprire la porta non è più necessario toccare la maniglia nè usare chiavi in condivisione con altre persone. Durata stimata circa 8 mesi (10 aperture giorno) con notifica di batteria scarica. Optional con possibilità di alimentarla tramite D-Smart (rimuovendo le batterie). Ordinare a parte il cavo CT8101XXXTA. Posizionabile ovunque nel raggio di 1 m.</p> <p>Transponder reader Mifare Classic wireless. <i>Bluetooth 5.0 BLE communication via D-SMART 2.0 APP to manage up to 150 users with different and customizable times. No Touch System: to open the door it is no longer necessary to touch the handle or use keys shared with other people. Estimated duration about 8 months (10 openings day) with low battery notification. Optional with the possibility of powering via D-Smart (removing the batteries). Order CT8101XXXTA cable separately. Can be positioned anywhere within 1 m.</i></p> <ul style="list-style-type: none"> Creazioni utenti da remoto tramite Dsmart Bridge on line. Creation users for remote opening: with on-line Dsmart Bridge. <p>DOTAZIONE STANDARD EQUIPMENT 1 trasponder criptato Mifare Classic - 2 batterie AAA 1 Mifare Classic encrypted transponder - 2 AAA batteries</p>	115
----------------	--	-----





D-SMART
Make your lock motorized
ON BRIDGE LINE

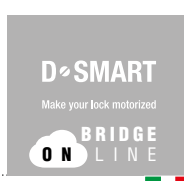

Codice Code	Descrizione Description	
8193XBK	<p>Letttore d'impronta (fingerprint) wireless. Comunicazione bluetooth 5.0 BLE tramite APP D-SMART 2.0 per gestire fino a 150 utenti con fasce orarie differenti e personalizzabili. Durata stimata circa 8 mesi (10 aperture giorno) con notifica di batteria scarica. Optional con possibilità di alimentarla tramite D-Smart (rimuovendo le batterie). Ordinare a parte il cavo CT8101XXXTA. Posizionabile ovunque nel raggio di 1 m.</p> <p>Bluetooth 5.0 BLE wireless fingerprint reader. <i>Bluetooth 5.0 BLE communication via D-SMART 2.0 APP to manage up to 150 users with different and customizable times. Estimated duration about 8 months (10 openings day) with low battery notification. Optional with the possibility of powering via D-Smart (removing the batteries). Order CT8101XXXTA cable separately. Can be positioned anywhere within 1 m.</i></p> <ul style="list-style-type: none"> Creazioni utenti da remoto tramite Dsmart Bridge on line. Creation users for remote opening: with on-line Dsmart Bridge. <p>DOTAZIONE STANDARD EQUIPMENT 2 batterie AAA 2 AAA batteries</p>	115



Codice Code	Descrizione Description	
8195XBK	<p>Tastiera elettronica TRE in UNO wireless. Apertura con codice numerico, transponder Mifare Classic e impronta digitale (fingerprint). Comunicazione bluetooth 5.0 BLE tramite APP D-SMART 2.0 per gestire fino a 150 utenti con fasce orarie differenti e personalizzabili. Durata stimata circa 8 mesi (10 aperture giorno) con notifica di batteria scarica. Optional con possibilità di alimentarla tramite D-Smart (rimuovendo le batterie). Ordinare a parte il cavo CT8190XXXTA. Posizionabile ovunque nel raggio di 1 m.</p> <p>THREE in ONE wireless electronic keyboard. <i>Opening with numeric code, Mifare Classic transponder and fingerprint. Bluetooth 5.0 BLE communication via D-SMART 2.0 APP to manage up to 150 users with different and customizable times. Estimated duration about 8 months (10 openings day) with low battery notification. Optional with the possibility of powering it via D-Smart (removing the batteries). Order CT8190XXXTA cable separately. Can be positioned anywhere within 1 m.</i></p> <ul style="list-style-type: none"> Creazione codici virtuali per aperture a distanza: Off-line tramite Guest-key e On-line tramite bridge Creation of virtual codes for remote opening: Off-line via Guest-key and On-line via bridge <p>DOTAZIONE STANDARD EQUIPMENT 1 trasponder criptato Mifare Classic - 3 batterie AA 1 Mifare Classic encrypted transponder - 3 AA batteries</p>	200

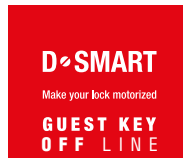
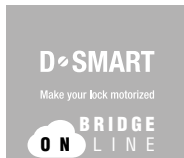



D-SMART

Make your lock motorized

GUEST KEY
OFF LINE

DSMART GUEST KEY - OFF LINE

Funziona tramite tastiera

Ideale per hotel | b&b, affitta camere, case vacanze, casa, azienda, ufficio, negozio, magazzino.

Dsmart Guest key è la soluzione ideale per abilitare la serratura con dei codici temporanei attivi solo per il periodo indicato e si cancelleranno automaticamente alla scadenza impostata. Automatizza il processo di check-in, check-out in totale assenza di personale d'accoglienza e in qualunque momento/orario.

Dsmart Guest key è un sistema dedicato all'ospitalità che permette di offrire un accesso porta con codice, **SENZA** alcuno strumento! **Semplicemente digitando un codice sulla tastiera.** Il codice può essere generato da tutto il mondo e condiviso con l'ospite via: e-mail, Whatsapp, SMS, telefonata, etc. Non è necessario nessuno collegamento wi-fi, modem o sim. Funziona senza connessioni con un sistema di algoritmi criptato che si basa su una OTP (one time password). Dsmart guest key genera un algoritmo in grado di capire che cosa significa la sequenza numerica digitata in tastiera (codice di ingresso). Imposta giorni e orari in cui l'ospite può accedere.

COME FARE?

🔴 Per creare il tuo account registrati sul sito Securemme/D-smart (<https://securemme.it/dsmart/>) compila i dati richiesti e segui la procedura guidata attivando la tua area riservata.

GESTIONE CHIAVI VIRTUALI

🔴 I codici temporanei vengono generati dal sito Dsmart Guest Key di Securemme direttamente dal proprietario, accedendo con le proprie credenziali e inserendo i dati richiesti (arrivo / partenza / nuove strutture /nuove serrature).

A procedura ultimata, verrà inviata una mail riassuntiva all'ospite, con il codice temporaneo, l'orario e il periodo abilitato e l'indirizzo. L'apertura della porta avverrà tramite Tastiera, inserendo i codici ricevuti via mail. La mail conterrà un link da cliccare per abilitare AUTOMATICAMENTE il codice tastiera. Funzione da effettuare fronte porta. Funziona con sistema di algoritmo criptato. Non ha bisogno di collegamenti wi-fi, modem o sim.

DSMART GUEST KEY - OFF LINE

Door opening with keyboard

*Ideal for hotels | b & b, rent rooms, holiday homes, home, company, office, shop, warehouse. Dsmart Guest key is the ideal solution to enable the lock with temporary codes active only for a certain period; at the end of the set period the code is automatically deleted and not valid anymore. Automate the check-in, check-out process in total absence of the reception staff and without time constrictions. Dsmart Guest key is a system dedicated to hospitality which allows to offer a door access with code, **WITHOUT** any tools! You can allow anyone to enter the door **simply by typing a code on the keyboard.** The code can be generated from anywhere around the world and shared with the guest via: e-mail, Whatsapp, SMS, phone call, etc. No wi-fi connection, modem or sim is needed. It works without connections, with a system of encrypted algorithms which are based on an OTP (one time password). Dsmart guest key generates an algorithm that is able to understand what the digitated number sequence means and so unlock the door (entry code). Set days and times on which the guest can access.*

HOW TO?

🔴 To create your account, register on the website Securemme / D-smart (<https://securemme.it/dsmart/>) fill in i data requested and follow the guided procedure by activating your reserved area.

VIRTUAL KEY MANAGEMENT

🔴 Temporary codes are generated from the Securemme Dsmart Guest site Key directly from the owner, by logging in with their credentials and entering the requested data (arrival / departure / new facilities / new locks). At the end of the procedure, a summary email will be sent to the guest, with the temporary code, time and period enabled and the address. The door will be opened with the keyboard, by entering the codes received by mail. The email will contain a link that will AUTOMATICALLY enable the keypad code. This function needs to be performed in front of the door. Works with system of encrypted algorithm. It does not need wi-fi connections, modem or sim.

Codice Code	Descrizione Description	 9
8200	<p>Dsmart Bridge è un dispositivo per il controllo a distanza, bluetooth wireless integrato su spina Schuko per D-Smart 2.0. Alimentazione 100-240 Vac. Comanda i Tuoi accessi ON LINE, da remoto e gestisci le impostazioni e gli utenti in tempo reale con Pc, tablet, smartphone.</p> <p>Aprire da remoto - Lascia entrare un operaio, una baby sitter, o un corriere anche quando non sei a casa. Controllo continuo - Controlla chi è entrato e uscito, mentre sei al lavoro, in viaggio o in vacanza.</p> <p>Integrated wireless bluetooth Bridge on Schuko plug for D-Smart 2.0. Power supply 100-240 Vac. Control your access ON LINE and manage settings and users in real time with PCs, tablets, smartphones.</p> <p>Remote Opening - Let a worker, babysitter, or courier in even when you are not at home. Continuous control - Check who has come and gone, while you are at work, traveling or on vacation.</p>	1000

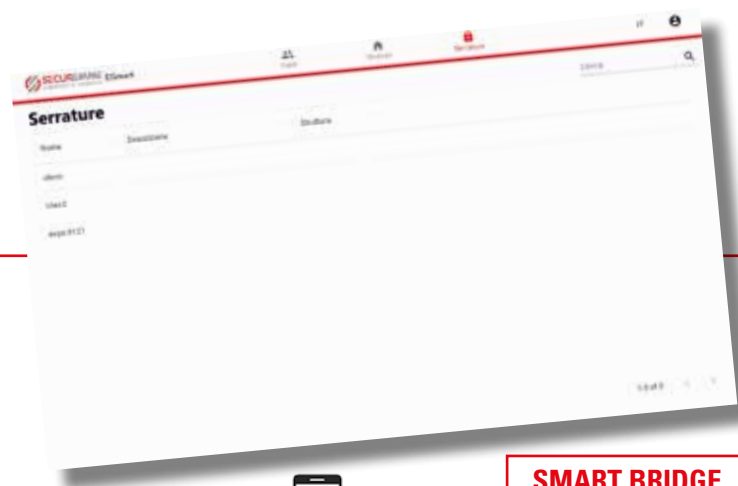
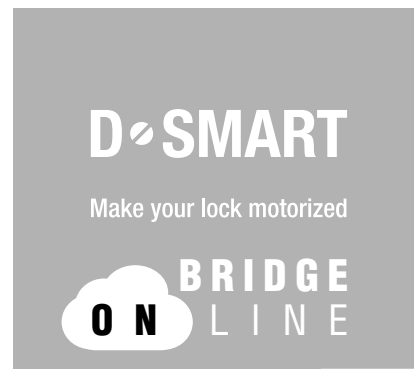
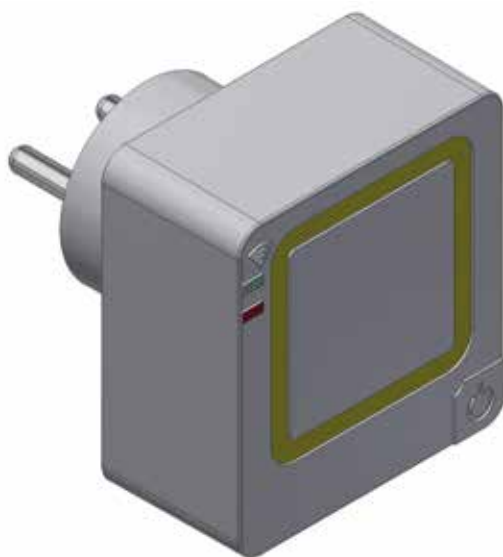

**PIATTAFORMA SMARTPHONE
SMARTPHONE PLATFORM**

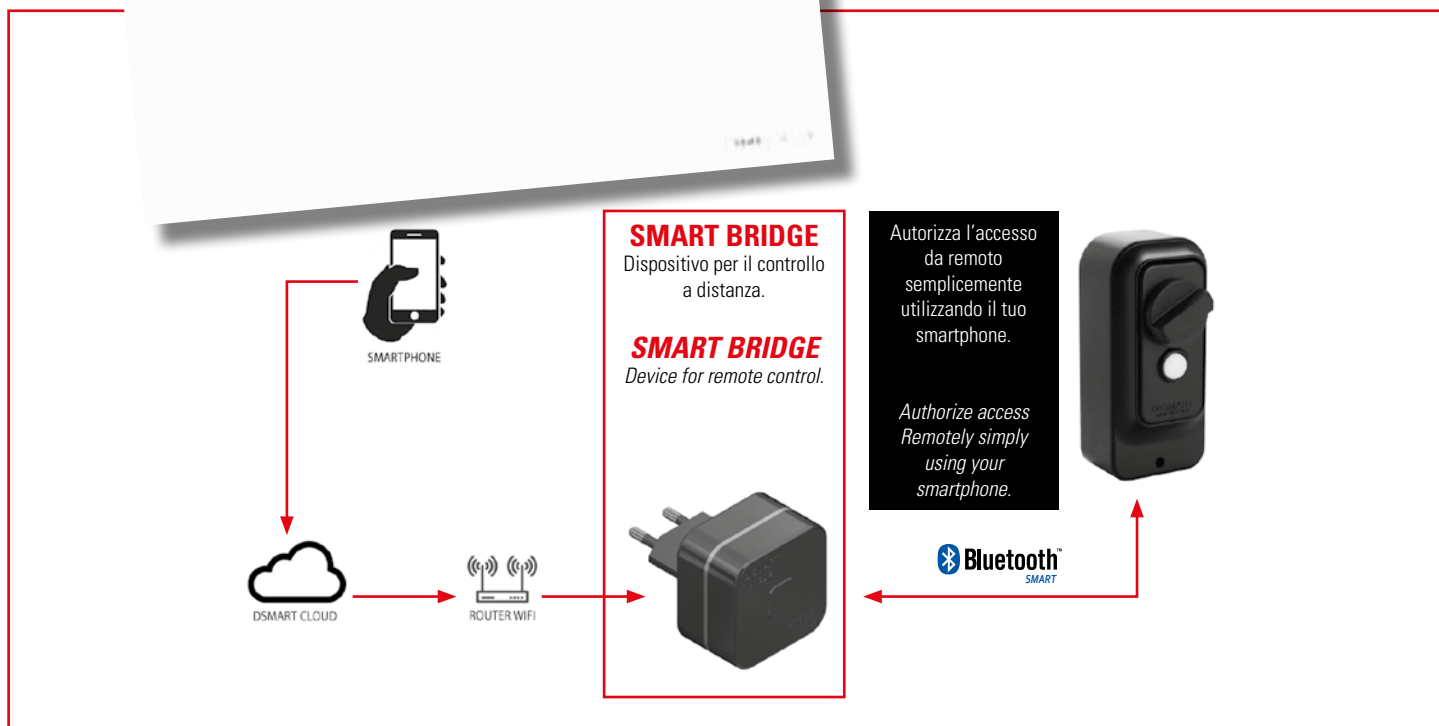

Codice Code	Descrizione Description	g
8210KBK8200 OPEN AIR	<p>Combinazione di dispositivi per trasformare ogni serratura elettrica in un accesso smart da remoto.</p> <p>In combinazione con il D-Smart Bridge in dotazione, è possibile aprire da remoto tramite APP o invito, un cancello elettrico pedonale, un cancello elettrico carrabile, una porta condominiale elettrica, una porta con incontro elettrico. Open Air è un sistema completo per accedere dalla strada alla propria casa senza l'uso di chiavi o dispositivi esterni (es. tastiera). Funzionamento con 3 batterie AA oppure con alimentazione da rete 12/24 V. Ideale per Hospitality.</p> <p><i>Combination of devices to turn each electric lock into a remote smart access.</i></p> <p><i>In combination with the D-Smart Bridge, included in standard supplied, it is possible to open remotely via APP or invitation, an electric pedestrian gate, an electric driveway gate, an electric residents door, a door endowed with an electric strike. So a complete system to access your home from the street without the use of keys or external devices (eg keyboard).</i></p> <p><i>Operation with 3 AA batteries or 12/24 V mains power supply. Ideal for Hospitality.</i></p> <ul style="list-style-type: none"> Creazione codici virtuali per aperture a distanza: On-line tramite Bridge. Creation of virtual codes for remote opening: On-line via Bridge. <p>DOTAZIONE I STANDARD EQUIPMENT</p> <p>Dispositivo figura 1 e Bridge figura 2 Se si collega un citofono e' necessario verificarne la compatibilità. Device figure 1 and Bridge figure 2 If an intercom have to be connected, its compatibility must be checked.</p>	150

D-SMART
Make your lock motorized

BRIDGE
ON LINE

Codice Code	Descrizione Description	g
8210XBK OPEN MAS	<p>Contatto pulito per integrare sistemi esterni di terzi (tastiere di terzi, controllo accessi di terzi) per apertura D-Smart 2.0 senza cablaggi. Alimentazione da rete 12/24 V.</p> <p>Clean contact to integrate third party external systems (third party keyboards, third party access control) for D-Smart 2.0 opening without wiring. 12/24 V mains power supply.</p>	150

Codice Code	Descrizione Description	 g
8222XBK EASY GATE 2	<p>Tastiera elettronica DUE in UNO wireless con 2 relè per apertura accessi, IP65. Ideale per cancello pedonale, carrabile, androne, riscontro elettrico.</p> <p>Elettronica di gestione integrata. Apertura con codice numerico, transponder Mifare Classic. Comunicazione bluetooth 5.0 BLE tramite APP D-SMART 2.0 per gestire fino a 150 utenti con fasce orarie differenti e personalizzabili. Durata stimata circa 8 mesi (10 aperture giorno) con notifica di batteria scarica. Funzionamento con 3 batterie AA oppure con alimentazione da rete 12/24 V. Creazione codici virtuali per aperture a distanza: Off-line tramite Guest-key.</p> <p>TWO in ONE wireless electronic keypad with 2 relays for access opening, IP65. Ideal for pedestrian gate, driveway, entrance hall, electric strike.</p> <p>Integrated management electronics. Opening with numeric code, Mifare Classic transponder. Bluetooth 5.0 BLE communication via D-SMART 2.0 APP to manage up to 150 users with different and customizable times. Estimated duration about 8 months (10 openings day) with low battery notification. Operation with 3 AA batteries or 12/24 V mains power supply. Creation of virtual codes for remote opening: Off-line via Guest-key.</p> <ul style="list-style-type: none"> Creazione codici virtuali per aperture a distanza: Off-line tramite Guest-key Creation of virtual codes for remote opening: Off-line via Guest-key <p>DOTAZIONE STANDARD EQUIPMENT 1 trasponder criptato Mifare Classic - 3 batterie AA 1 Mifare Classic encrypted transponder - 3 AA batteries</p>	200



Codice Code	Descrizione Description	 g
8222KBK8210 SUPER GATE 2	<p>Tastiera elettronica DUE in UNO wireless con 2 relè per apertura accessi, IP65. Ideale per cancello pedonale, carrabile, androne, riscontro elettrico.</p> <p>Elettronica di gestione separata. Apertura con codice numerico, transponder Mifare Classic. Comunicazione bluetooth 5.0 BLE tramite APP D-SMART 2.0 per gestire fino a 150 utenti con fasce orarie differenti e personalizzabili. Durata stimata circa 8 mesi (10 aperture giorno) con notifica di batteria scarica. Funzionamento con 3 batterie AA oppure con alimentazione da rete 12/24 V. Creazione codici virtuali per aperture a distanza: Off-line tramite Guest-key.</p> <p>TWO in ONE wireless electronic keypad with 2 relays for access opening, IP65. Ideal for pedestrian gate, driveway, entrance hall, electric strike.</p> <p>Separate management electronics. Opening with numeric code, Mifare Classic transponder. Bluetooth 5.0 BLE communication via D-SMART 2.0 APP to manage up to 150 users with different and customizable times. Estimated duration about 8 months (10 openings day) with low battery notification. Operation with 3 AA batteries or 12/24 V mains power supply. Creation of virtual codes for remote opening: Off-line via Guest-key.</p> <ul style="list-style-type: none"> Creazione codici virtuali per aperture a distanza: Off-line tramite Guest-key Creation of virtual codes for remote opening: Off-line via Guest-key <p>DOTAZIONE STANDARD EQUIPMENT 1 trasponder criptato Mifare Classic - 3 batterie AA 1 Mifare Classic encrypted transponder - 3 AA batteries</p>	220





Codice Code	Descrizione Description	 g
8223XBK EASY GATE 3	<p>Tastiera elettronica TRE in UNO Easy Gate 3 wireless con 2 relè per apertura accessi, IP65. Ideale per cancello pedonale, carrabile, androne, riscontro elettrico. Elettronica di gestione integrata. Apertura con codice numerico, transponder Mifare Classic e impronta digitale (fingerprint). Comunicazione bluetooth 5.0 BLE tramite APP D-SMART 2.0 per gestire fino a 150 utenti con fasce orarie differenti e personalizzabili. Durata stimata circa 8 mesi (10 aperture giorno) con notifica di batteria scarica. Funzionamento con 3 batterie AA oppure con alimentazione da rete 12/24 V. Creazione codici virtuali per aperture a distanza: Off-line tramite Guest-key.</p> <p>THREE in ONE Easy Gate 3 wireless electronic keypad with 2 relays for access opening, IP65. <i>Ideal for pedestrian gate, driveway, entrance hall, electric strike.</i> Integrated management electronics. <i>Opening with numeric code, Mifare Classic transponder and fingerprint.</i> <i>Bluetooth 5.0 BLE communication via D-SMART 2.0 APP to manage up to 150 users with different and customizable times. Estimated duration about 8 months (10 openings day) with low battery notification.</i> <i>Operation with 3 AA batteries or 12/24 V mains power supply. Creation of virtual codes for remote opening: Off-line via Guest-key.</i></p> <ul style="list-style-type: none"> Creazione codici virtuali per aperture a distanza: Off-line tramite Guest-key Creation of virtual codes for remote opening: Off-line via Guest-key <p>DOTAZIONE STANDARD EQUIPMENT 1 trasponder criptato Mifare Classic - 3 batterie AA 1 Mifare Classic encrypted transponder - 3 AA batteries</p>	200

D-SMART
Make your lock motorized
GUEST KEY OFF LINE





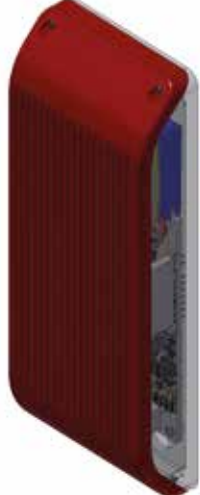





Codice Code	Descrizione Description	 g	INTERNO INSIDE	ESTERNO OUTSIDE
8223KBK8210 SUPER GATE 3	<p>Tastiera elettronica TRE in UNO Super Gate 3 wireless con 2 relè per apertura accessi, IP65. Ideale per cancello pedonale, carrabile, androne, riscontro elettrico. Elettronica di gestione separata. Apertura con codice numerico, transponder Mifare Classic e impronta digitale (fingerprint). Comunicazione bluetooth 5.0 BLE tramite APP D-SMART 2.0 per gestire fino a 150 utenti con fasce orarie differenti e personalizzabili. Durata stimata circa 8 mesi (10 aperture giorno) con notifica di batteria scarica. Funzionamento con 3 batterie AA oppure con alimentazione da rete 12/24 V. Creazione codici virtuali per aperture a distanza: Off-line tramite Guest-key.</p> <p>THREE in ONE Super Gate 3 wireless electronic keypad with 2 relays for access opening, IP65. <i>Ideal for pedestrian gate, driveway, entrance hall, electric strike.</i> Separate management electronics. <i>Opening with numeric code, Mifare Classic transponder and fingerprint.</i> <i>Bluetooth 5.0 BLE communication via D-SMART 2.0 APP to manage up to 150 users with different and customizable times. Estimated duration about 8 months (10 openings day) with low battery notification.</i> <i>Operation with 3 AA batteries or 12/24 V mains power supply. Creation of virtual codes for remote opening: Off-line via Guest-key.</i></p> <ul style="list-style-type: none"> Creazione codici virtuali per aperture a distanza: Off-line tramite Guest-key Creation of virtual codes for remote opening: Off-line via Guest-key <p>DOTAZIONE STANDARD EQUIPMENT 1 trasponder criptato Mifare Classic - 3 batterie AA 1 Mifare Classic encrypted transponder - 3 AA batteries</p>	220		

D-SMART
Make your lock motorized
GUEST KEY OFF LINE



Codice Code	Descrizione Description	 g
-------------	-------------------------	---

8232XBK OPEN RADIO 2 **Tastiera elettronica DUE in UNO** con ricevitore RF (radio frequenza), IP65.
Portata fino a 100 m dipendenti dalle condizioni edilizie. Ideale per cancello pedonale, carrabile, androne, riscontro elettrico.
Electronica di gestione integrata.
Apertura con codice numerico, transponder Mifare Classic. Comunicazione bluetooth 5.0 BLE tramite APP D-SMART 2.0 per gestire fino a 150 utenti con fasce orarie differenti e personalizzabili. Durata stimata circa 8 mesi (10 aperture giorno) con notifica di batteria scarica.
Funzionamento con 3 batterie AA oppure con alimentazione da rete 12/24 V.
Creazione codici virtuali per aperture a distanza: Off-line tramite Guest-key.

TWO in ONE electronic keypad with RF (radio frequency) receiver, IP65.
Range up to 100 m depending on building conditions.
Ideal for pedestrian gate, driveway, entrance hall, electric strike.
Integrated management electronics.
Opening with numeric code, Mifare Classic transponder. Bluetooth 5.0 BLE communication via D-SMART 2.0 APP to manage up to 150 users with different and customizable times. Estimated duration about 8 months (10 openings day) with low battery notification.
Operation with 3 AA batteries or 12/24 V mains power supply.
Creation of virtual codes for remote opening: Off-line via Guest-key.

- Creazione codici virtuali per aperture a distanza: Off-line tramite Guest-key
- Creation of virtual codes for remote opening: Off-line via Guest-key

220

INTERNO
INSIDE



ESTERNO
OUTSIDE

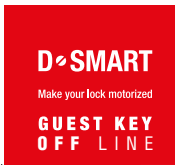

DOTAZIONE | STANDARD EQUIPMENT
1 transponder criptato Mifare Classic - 3 batterie AA
1 Mifare Classic encrypted transponder - 3 AA batteries

Codice Code	Descrizione Description	 g
-------------	-------------------------	---

8233XBK OPEN RADIO 3 **Tastiera elettronica TRE in UNO** con ricevitore RF (radio frequenza), IP65.
Portata fino a 100 m dipendenti dalle condizioni edilizie. Ideale per cancello pedonale, carrabile, androne, riscontro elettrico.
Electronica di gestione integrata.
Apertura con codice numerico, transponder Mifare Classic e impronta digitale (fingerprint). Comunicazione bluetooth 5.0 BLE tramite APP D-SMART 2.0 per gestire fino a 150 utenti con fasce orarie differenti e personalizzabili. Durata stimata circa 8 mesi (10 aperture giorno) con notifica di batteria scarica.
Funzionamento con 3 batterie AA oppure con alimentazione da rete 12/24 V.
Creazione codici virtuali per aperture a distanza: Off-line tramite Guest-key.

THREE in ONE electronic keypad with RF (radio frequency) receiver, IP65.
Range up to 100 m depending on building conditions.
Ideal for pedestrian gate, driveway, entrance hall, electric strike.
Integrated management electronics.
Opening with numeric code, Mifare Classic transponder and fingerprint. Bluetooth 5.0 BLE communication via D-SMART 2.0 APP to manage up to 150 users with different and customizable times. Estimated duration about 8 months (10 openings day) with low battery notification.
Operation with 3 AA batteries or with 12/24 V mains power supply.
Creation of virtual codes for remote opening: Off-line via Guest-key.

- Creazione codici virtuali per aperture a distanza: Off-line tramite Guest-key
- Creation of virtual codes for remote opening: Off-line via Guest-key

220

INTERNO
INSIDE



ESTERNO
OUTSIDE

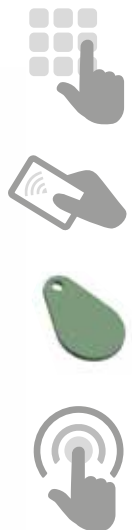

DOTAZIONE | STANDARD EQUIPMENT
1 transponder criptato Mifare Classic - 3 batterie AA
1 Mifare Classic encrypted transponder - 3 AA batteries

CILINDRO ELETTRONICO MODULARE ENOK.

Apertura con transponder. Non necessita di cablaggi.

CARATTERISTICHE TECNICHE

- > Pomolo esterno azionabile elettronicamente
- > Compatibile con serratura meccanica predisposta per cilindro a profilo europeo
- > 2 Batterie al litio tipo CR-2
- > Durata batterie 30.000 cicli (circa 3 anni). Segnalazione batteria scarica
- > Retroilluminazione a LED
- > Tecnologia contactless RFID ISO 144443B / Mifare ISO 14443°
- > Campo di lettura < 20 mm
- > Capacità fino a 99 chiavi

Applicazione: interni/esterni IP65

Temperatura di utilizzo: da -20°C a + 65°C



ENOK ELECTRONIC MODULAR CYLINDER.

Opening with transponder. Without cables.

CHNICAL FEATURES

- > External knob with electrical control
- > Compatible with mechanical lock designed for European profile cylinder
- > 2 CR-2 lithium batteries
- > Battery life 30,000 cycles (about 3 years). Low battery warning
- > LED backlight
- > Technology contactless RFID ISO 144443B / Mifare ISO 14443°
- > Reading range < 20 mm
- > Capacity maximum 99 keys

Usage: indoor/outdoor IP65



Operating temperature: from -20°C to + 65°C

Codice Code	Descrizione Description	g	W
3E00PCS32321X3	<p>Cilindro modulare pomolo meccanico - pomolo elettronico. Parte interna pomolo meccanico Ø34. Parte esterna pomolo elettronico Ø40 mm. Apertura con transponder Mifare. Assemblando al corpo cilindro da 32 mm i distanziali di 5/10/20 mm si adatta facilmente ad ogni spessore di porta evitando stock di magazzino e pronto intervento in loco.</p> <p><i>Modular cylinder mechanical knob - electronic knob. Internal part mechanical knob Ø34. External part electronic knob Ø40 mm. Opening with Mifare transponder. It easily adapts to any door thickness by assembling the 5/10/20 mm spacers to the 32 mm cylinder body, thus avoiding warehouse stocks and allowing prompt intervention on site.</i></p> <p>DOTAZIONE STANDARD EQUIPMENT 1 trasponder master per aggiungere/eliminare, 3 trasponder, 2 batterie CR2. <i>1 master transponder to add / remove, 3 transponders, 2 CR2 batteries.</i></p>	1000	



3E00QCS32321X3	<p>Cilindro modulare codolo meccanico - pomolo elettronico. Parte interna codolo meccanico Ø8. Parte esterna pomolo elettronico Ø40 mm. Apertura con transponder Mifare. Assemblando al corpo cilindro da 32 mm i distanziali di 5/10/20 mm si adatta facilmente ad ogni spessore di porta evitando stock di magazzino e pronto intervento in loco. Dotazione 1 trasponder master per aggiungere/eliminare, 3 trasponder, 2 batterie CR2.</p> <p><i>Modular cylinder with mechanical knob predisposition - electronic knob. Internal part mechanical knob predisposition Ø8. External part electronic knob Ø40 mm. Opening with Mifare transponder. It easily adapts to any door thickness by assembling the 5/10/20 mm spacers to the 32 mm cylinder body, thus avoiding warehouse stocks and allowing prompt intervention on site.</i></p> <p>DOTAZIONE STANDARD EQUIPMENT 1 trasponder master per aggiungere/eliminare, 3 trasponder, 2 batterie CR2. <i>1 master transponder to add/remove, 3 transponders, 2 CR2 batteries.</i></p>	1000	
-----------------------	---	------	--

3E00MCS32101X3	<p>Mezzo cilindro modulare - pomolo elettronico Ø40 mm. Apertura con transponder Mifare. Assemblando al corpo cilindro da 32 mm i distanziali di 5/10/20 mm si adatta facilmente ad ogni spessore di porta evitando stock di magazzino e pronto intervento in loco.</p> <p><i>Modular half cylinder - electronic knob Ø40 mm. Opening with Mifare transponder. It easily adapts to any door thickness by assembling the 5/10/20 mm spacers to the 32 mm cylinder body, thus avoiding warehouse stocks and allowing prompt intervention on site.</i></p> <p>DOTAZIONE STANDARD EQUIPMENT 1 trasponder master per aggiungere/eliminare, 3 trasponder, 2 batterie CR2. <i>1 master transponder to add / remove, 3 transponders, 2 CR2 batteries.</i></p>	1000	
-----------------------	--	------	--

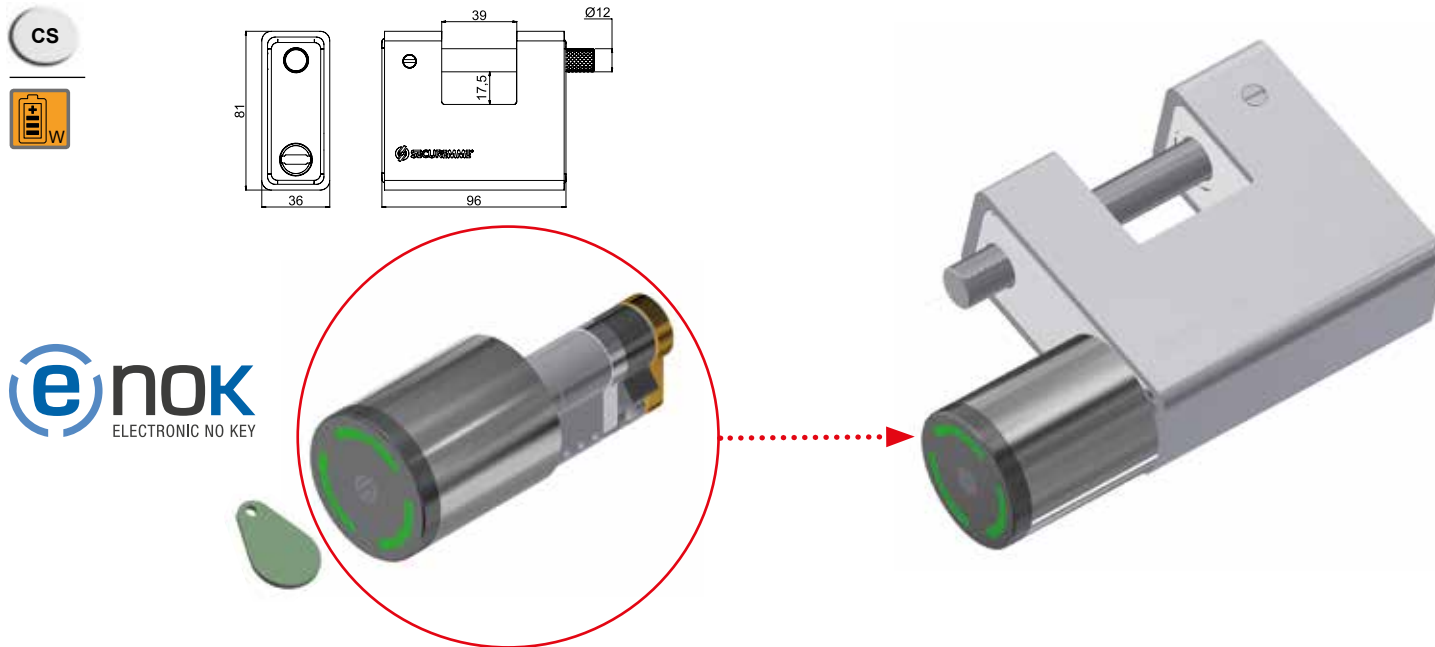

Codice Code	Descrizione Description	 5 - 20	 1206
7500ECS	<p>Lucchetto corazzato con mezzo cilindro elettronico Enok 30-10 mm. Tipo di apertura/chiusura: trasponder Mifare Classic. Batteria CR2 Pomolo 34 mm 3232.</p> <p><i>Armored padlock with Enok 30-10 mm electronic half cylinder</i> <i>Type of opening/closing: Mifare Classic transponder.</i> <i>CR2 battery Knob 34 mm 3232.</i></p>		

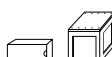

Codice Code	Descrizione Description	 5 - 20	 524
7550ECS	<p>Lucchetto ad arco con mezzo cilindro elettronico Enok 30-10 mm. Tipo di apertura/chiusura: trasponder mifare classic. Batteria CR2 Pomolo 34 mm 3232.</p> <p><i>Arched padlock with Enok 30-10 mm electronic half cylinder.</i> <i>Type of opening / closing: Mifare Classic transponder.</i> <i>CR2 battery Knob 34 mm 3232.</i></p>		

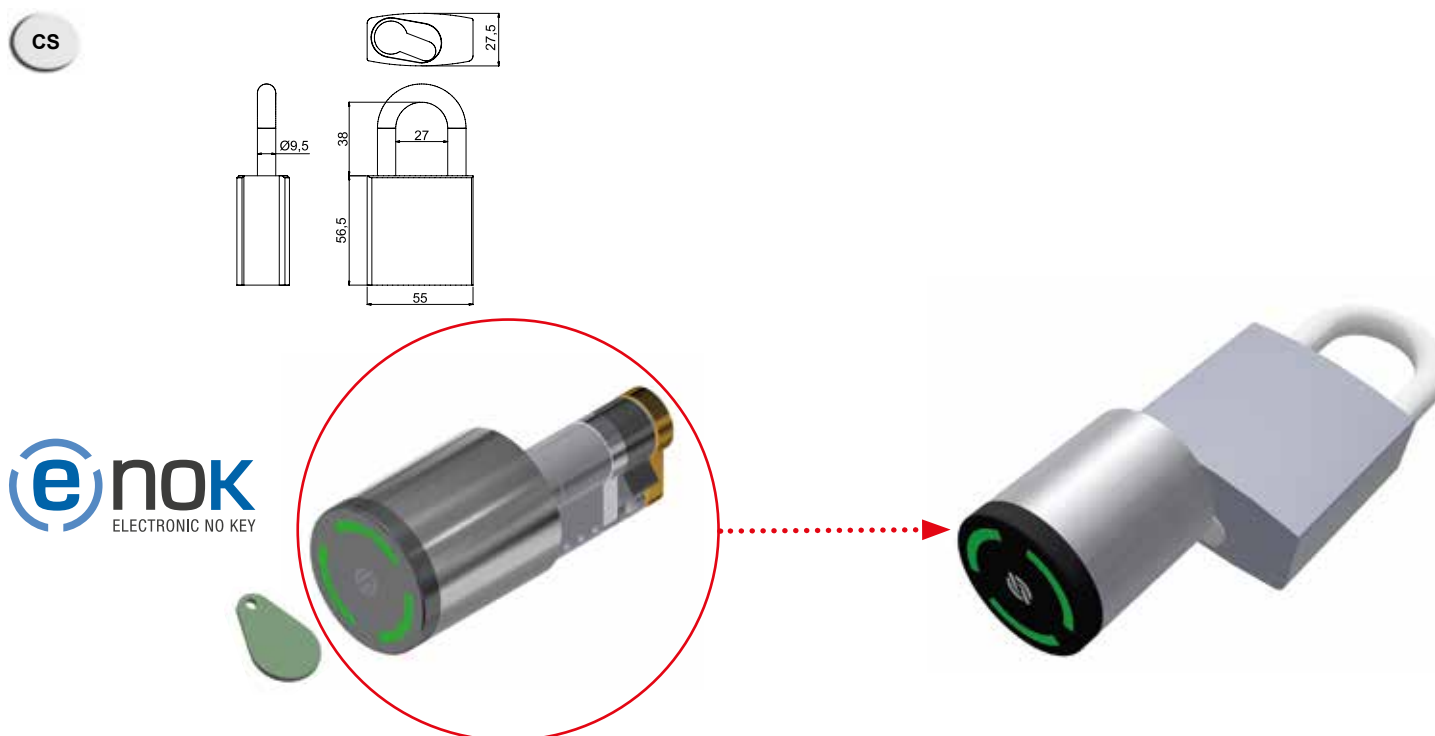

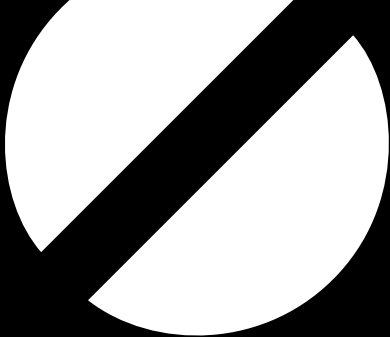

DIMENTICA LE CHIAVI, utilizza smartphone e i dispositivi wireless dedicati, per creare ed inviare codici temporanei da qualsiasi dispositivo mobile e aprire anche da remoto.

FORGET THE KEYS, use smartphones and dedicated wireless devices to create and send temporary codes from any mobile device and you can also open the door remotely.

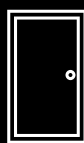

Possono essere installati su **QUALUNQUE TIPO DI ACCESSO** (porte, cancelli, barriere, porte antincendio).

They can be installed on **ANY TYPE OF ACCESS** (doors, gates, fire doors).



Soluzioni ideali per la tua **CASA**, per gestire gli spazi **BUSINESS** (co-working, uffici, ecc.) e il mondo dell'**HOSPITALITY** (B&B, appartamenti in affitto breve, ecc)

Ideal solutions for your **HOME**, to manage **BUSINESS** spaces (co-working, offices, etc.) and - above all - the world of **HOSPITALITY** (B&B, short-term rental apartments, etc.)

A CASA: entra utilizzando lo Smartphone e i dispositivi dedicati (tastiere, transponder, lettore d'impronta ecc.) Grazie alla funzione **Automatic Lock** sarai sempre certo di aver chiuso la Tua porta con tutte le mandate.

AT HOME: enter using your Smartphone and dedicated devices (keyboards, transponders, fingerprint readers etc.). Thanks to the **Automatic Lock** function you will always be sure that you have closed your door with all the turns.

BUSINESS: programmi gli accessi per i dipendenti solo in **orari predefiniti** ed imposti la **chiusura automatica**.

BUSINESS: access for employees only at **predefined times**. You can set **automatic closing times**.

HOSPITALITY: Check-In e Check-Out 24 ore su 24, 7 giorni su 7 a qualsiasi ora del giorno e della notte in completa autonomia grazie al software off-line D-Smart Guest Key o al Bridge on-line su cloud.

HOSPITALITY: Check-In and Check-Out 24 hours a day, 7 days a week at any time of day or night in complete autonomy thanks to the D-Smart Guest Key off-line software or the on-line cloud Bridge.



SECUREMME SRL
Via del Lavoro, 6/8
23854 Olginate (LC) Italy



Tel. ++39 0341.605.243
Fax ++39 0341.605.486



www.securemme.it
info@securemme.it

SISTEMA GESTIONE QUALITÀ
UNI EN ISO 9001:2015