

Reference: D09-1346 / 25.11.2011

Reference: L09-1346 / 25.11.2011

 greenbuildingproducts.eu

Product Declaration - DGNB Neubauversion Büro- und Verwaltungsgebäude (NBV09)

Manufacturer **BOSIG Baukunststoffe GmbH**

Product Name **PHONOTHERM® 200**



Product Rating

- The product fulfills the requirements of action level 1 to 4 and contributes to achieve 10 (of max. 10) criterion points within Criterion 06 'Risks for the regional environment'.

 greenbuildingproducts.eu

Produkt Declaration - LEED® 2009 New Construction And Major Renovations NC & CS

Manufacturer **BOSIG Baukunststoffe GmbH**

Product Name **PHONOTHERM® 200**



Product Rating

- The product contains 50% recycled materials and contribute to achieve LEED credits within MR Credit 4.

Phonotherm® 200 boards are made of high quality CFC-, HCFC- and formaldehyde-free polyurethane hard foams. In a special composition including the addition of auxiliary materials this material is pressed into high quality boards. Phonotherm® 200 is a functional material that convinces through extraordinary properties. Phonotherm® 200 is moisture-resistant and has excellent thermal insulation properties.

Its resistance to moisture makes Phonotherm® 200 very durable and prevents it from rotting. This renders Phonotherm® 200 far superior to conventional wooden boards such as press boards and MDF boards, yet has similar machining properties.

Phonotherm® 200 can be machined using normal carbide tools and can even be milled in fine detail without danger of break-out. Phonotherm® 200 is also resistant to chemicals, easy to work and can be laminated and combined with other materials.



**General German Construction Inspection
Certification Report no. P-2008-B-4237**

Examples of application areas: Phonotherm® 200 has many applications. It is used, among other, for partitions in wet and damp rooms, as concealed edges or edge bands for doors for wet and damp rooms, window finishing profiles, roller shutter boxes, working boards in kitchen, façade construction, spacers, decoupling plates in buildings and in vehicles (e.g. to prevent thermal bridges).

Environmental protection: The created waste is 100% recyclable. Phonotherm® 200 is free of formaldehydes and does not emit physiologically significant quantities of chemical substances.

Processing: Use conventional tungsten-carbide tipped woodworking machinery for working. In principle, we recommend an extraction system. The dust created during machining (sawing, grinding, milling) is physiologically harmless and not fibrous. Pre-drill before screwing or use self-drill screws. Phonotherm® 200 can be screwed, the material can be milled, ground, drilled and can be glued together.

Gluing: Gluing of butt joints of boards, cuts and strips is simple, using 2-component polyurethane adhesives for instance. Single or 2-component polyurethane adhesives are suitable for gluing of surfaces. For assistance please enquire about your specific application.

Storage and transport:

Phonotherm® 200 should be stored dry and on a flat surface. It is not subject to the Ordinance on Hazardous Substances or other storage and transport regulations.

The advantages:

- economical
- moisture-resistant
- does not age or rot
- resists roots
- good thermal insulation properties
- temperature-resistant
- very good resistance to chemicals
- recyclable
- biologically and ecologically harmless, resistant against fungi and rot
- easy to work

Dimensions:

Standard sizes:		2400 x 1350 mm
		3600 x 1350 mm
Thicknesses:	RG 500	from 15 mm to 60 mm
	RG 700	from 10 mm to 50 mm

Other sizes and thicknesses are available on request.

Technical data:

Phonotherm 200	RG 500	RG 700	
Material	CFC-, HCFC- and formaldehyde-free polyurethane hard foam material		
Raw density	550 ± 50 kg / m ³	700 ± 50 kg / m ³	
Bending strength	approx. 7.8 N / mm ²	approx. 10.5 N / mm ²	according to DIN EN 310
Compression strength	approx. 7000 kPa	approx. 8100 kPa	DIN EN 826
Modulus of elasticity	approx. 500 N / mm ²	approx. 750 N / mm ²	
Screw withdrawal resistance*	approx. 650 N	approx. 800 N	according to DIN EN 320
Thickness swell after 24 h in water	approx. 1 %	approx. 1 %	Intern.
Water absorption after 24 h in water	approx. 5 %	approx. 4 %	Intern.
Dimensional change after 24 h in water	approx. 1 %	approx. 1 %	Intern.
Elongation coefficient in the range – 20 to + 60 °C	approx. 28.375 · 10 ⁻⁶ / K	approx. 28.375 · 10 ⁻⁶ / K	according to DIN 51045-1
Water vapour diffusion resistance values for 15 mm (5/ 8") material thickness for 20 mm (3/4") material thickness for 30 mm (1 3/16") material thickness for 50 mm (2") material thickness	μ approx. 17 / s _d approx. 0.27 m μ approx. 27 / s _d approx. 1.4 m	μ approx. 25 / s _d approx. 0.37 m μ approx. 23 / s _d approx. 0.47 m μ approx. 46 / s _d approx. 1.4 m	DIN EN ISO 12572 / DIN 52 615
Thermal conductivity λ ₁₀	approx. 0.076 W / (m·K)	approx. 0.10 W / (m·K)	EN 12 667 / DIN 52 612
Fire behaviour	building material class B2 non-flammable drop free	building material class B2 non-flammable drop free	DIN 4102
	Class E	Class E	DIN EN 13501-1
Residual moisture	2 – 4 %		
Thickness tolerance, not sanded	± 0.4 mm		
Thickness tolerance, sanded	± 0.2 mm		
Thermal stability	– 40 °C to + 80 °C		
Resistance against ageing	resistance against putrefaction and non-rotting		

* Test screw: SPAX® T-Star plus 4,0 x 60

Special sizes and laminations are possible in principle. We can tailor the boards to suit most of your needs. This would require a detailed discussion and drawings, if possible. Please contact us for information.

Phonotherm® 200 thermal transmission coefficient U, as a measure of the thermal conductivity in acc. with DIN 4108:

Model for non-plastered profiles (Fig. 1.)

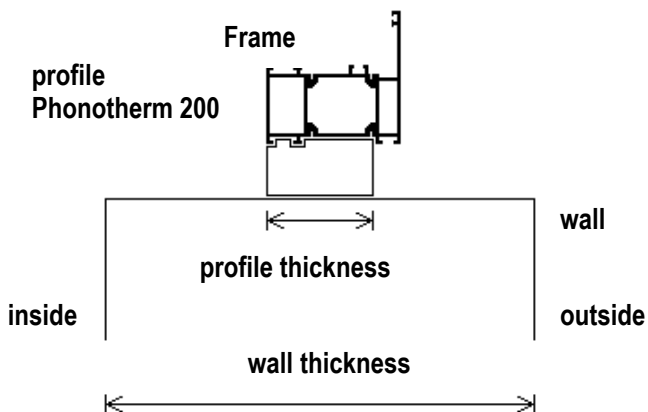

Fig. 1: non-plastered profile

Model for open gap between two concrete pre-cast components (Fig. 2.)

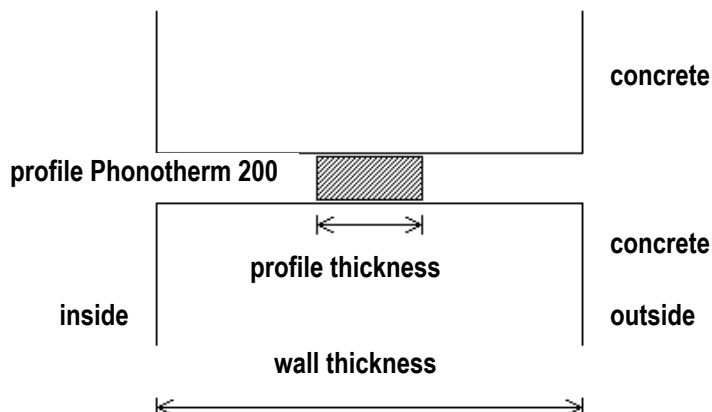

Fig. 2: Phonotherm® 200 – installation example for thermal transfer from inside out

with:

$$1 / U = R_T = s / \lambda_{10} + R_{si} + R_{se}$$

- s = Board thickness
- λ_{10} = Thermal conductivity
- R_{si} / R_{se} = Thermal transfer resistance
- $R_T = 1 / U$ = Thermal transmission resistance
- U = Thermal transmission coefficient**

Thermal conductivity of Phonotherm® 200, RG 500
 Thermal conductivity of Phonotherm® 200, RG 700
 Thermal transfer resistance inside
 Thermal transfer resistance outside

measured value in acc. with EN 12 887
 measured value in acc. with DIN 52 612
 in acc. with DIN 4108
 in acc. with DIN 4108

$\lambda_{10} = 0.0761 \text{ W} / (\text{m} \cdot \text{K})$
 $\lambda_{10} = 0.1012 \text{ W} / (\text{m} \cdot \text{K})$
 $R_{si} = 0.13 (\text{m}^2 \cdot \text{K}) / \text{W}$
 $R_{se} = 0.04 (\text{m}^2 \cdot \text{K}) / \text{W}$

Board thickness s [mm]	Phonotherm® 200, RG 500 $\lambda = 0.0761 \text{ W} / (\text{m} \cdot \text{K})$		Phonotherm® 200, RG 700 $\lambda = 0.1012 \text{ W} / (\text{m} \cdot \text{K})$	
	$s / \lambda [(\text{m}^2 \cdot \text{K}) / \text{W}]$	U [W / (m²·K)]	$s / \lambda [(\text{m}^2 \cdot \text{K}) / \text{W}]$	U [W / (m²·K)]
10			0.099	3.72
15	0.197	2.72	0.148	3.14
20	0.263	2.31	0.198	2.72
25	0.329	2.01	0.247	2.40
30	0.394	1.77	0.296	2.14
35	0.460	1.59	0.346	1.94
40	0.526	1.44	0.395	1.77
45	0.591	1.31	0.446	1.63
50	0.657	1.21	0.494	1.51
55	0.723	1.12		
60	0.788	1.04		

Tab. 1:

Thermal resistance s / λ and thermal transmission coefficient U as a function of board thickness.
 Please note: These are measured values, without correction factors in acc. with DIN 4108.

Thermal Bridge Coefficient Ψ (P_{si} -value) and Temperature Factor f_{Rsi} the Phonotherm® 200 as degree for the confirmation of thermal bridges according to EnEV (German law for energy savings) for Phonotherm 200 as base profile for window construction:

Thermal Bridge Coefficient Ψ (P_{si} -value)	Requirement of DIN 4108
0.057 W/(mK)	≤ 0.090 W/(mK) Conditions fulfilled
Temperature Factor f_{Rsi}	Requirement of DIN 4108
0.80	≥ 0.70 Conditions fulfilled

Tab. 2.

Use of base profiles made from Phonotherm 200 meets the requirements of German standard DIN 4108-supplement 2. The blanket confirmation of thermal bridge conditions according to EnEV may be applied.

Basic conditions:

The structural and climatical conditions meet requirements of the German standard DIN 4108-supplement 2, and standardized conditions of DIN ISO 10211. For simplification of the calculation, the building component window was adopted as a board with a thickness of 70 mm.

Attention! Important Note:

Above information are based on best present knowledge of current technology, but do not guarantee faultless processing of our products. The information is based on practical results of our tests, but is not binding and does not constitute warranties of characteristics in terms of Federal Supreme Court jurisdiction. Our information does not constitute a legally binding assurance of certain properties or suitability for a specific purpose. Supplementary information by our specialists are merely recommendations, for which no liability is accepted.

Due to the many possible applications of our products, we recommend subjecting the project to a thorough suitability test on original materials before release for further application.

Since our information are non-binding we do not warranty their correctness. For this reason we accept no liability for possible improper processing based on information submitted by our employees.

This technical data sheet replaces all previous versions and is valid until a new version is issued, or until Dec. 31, 2015. Please request the latest version after Jan. 01, 2016.

Dr. Hermann, Anwendungstechnik / Application Technology, Gingen / Fils